

**TECHNICAL MANUAL**

**AVIATION UNIT AND INTERMEDIATE  
MAINTENANCE MANUAL**

**ARMY MODEL  
AH-1P (PROD)  
AH-1E (ECAS)  
AH-1F (MODERNIZED COBRA)  
HELICOPTERS**

“Approved for public release; distribution is unlimited.”

---

**HEADQUARTERS, DEPARTMENT OF THE ARMY  
8 MAY 1980**



CHANGE

NO. 22

HEADQUARTERS  
DEPARTMENT OF THE ARMY  
WASHINGTON, D.C., 30 April 1996

Aviation Unit and Intermediate  
Maintenance Manual

ARMY MODEL  
AH-1 P (PROD)  
AH-1 E (ECAS)  
AH-1F (MODERNIZED COBRA)  
HELICOPTERS

DISTRIBUTION STATEMENT A: Approved for public release; distribution is unlimited.

TM 55-1520-236-23-2, 8 May 1980, is changed as follows:

1. Remove and insert pages as indicated below. New or changed text material is indicated by a vertical bar in the margin. An illustration change is indicated by a miniature pointing hand.

Remove pages

i and ii  
v and vi  
xix and xx  
7-55 through 7-58  
8-7 and 8-8  
8-17 and 8-18  
8-23 and 8-24  
9-23 and 9-24  
9-29 and 9-30  
9-85 and 9-86  
9-86.1/(9-86.2 blank)  
9-97 and 9-98  
9-101 through 9-104  
9-111 and 9-112  
10-5 through 10-8  
10-11 and 10-12  
10-13 through 10-16  
11-28.1 and 11-28.2  
11-29 through 11-32  
11-79 and 11-80  
16-7 and 16-8

Insert pages

i and ii  
v and vi  
xix and xx  
7-55 through 7-58  
8-7 and 8-8  
8-17 and 8-18  
8-23 and 8-24  
8-23 and 9-24  
9-29 and 9-30  
9-85 and 9-86  
9-86.1 and 9-86.2  
9-97 and 9-88  
9-101 through 9-104  
9-111 and 9-112  
10-5 through 10-8  
10-11 and 10-12  
10-13 through 10-16  
11-28.1 and 11-28.2  
11-29 through 11-32  
11-79 and 11-80  
16-7 and 16-8

**Remove pages**

16-11 and 16-12

16-19 and 16-20

16-27 and 16-28

16-31 and 16-32

**Insert pages**

16-11 and 16-12

16-19 and 16-20

16-27 and 16-28

16-31 and 16-32

2. Retain this sheet in front of manual for reference purposes.

By Order of the Secretary of the Army:

Official:

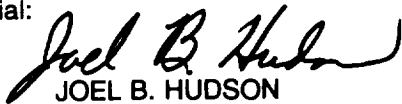

JOEL B. HUDSON

*Acting Administrative Assistant to the  
Secretary of the Army*

01609

**DENNIS J. REIMER**  
*General, United States Army*  
*Chief of Staff*

**DISTRIBUTION:**

To be distributed in accordance with DA Form 12-31-E, block no. 1149, requirements for  
TM 55-1520-236-23-2.

# URGENT

TM 55-1520-236-23-2

C 21

CHANGE

NO. 21

HEADQUARTERS  
DEPARTMENT OF THE ARMY  
WASHINGTON, D. C., 31 October 1995

## Aviation Unit and Intermediate Maintenance Manual

ARMY MODEL  
AH-1P (PROD)  
AH-1E (ECAS)  
AH-1F (MODERNIZED COBRA)  
HELICOPTERS

DISTRIBUTION STATEMENT A: Approved for public release; distribution is unlimited

TM 55-1520-236-23-2, 8 May 1980, is changed as follows:

1. Remove and insert pages as indicated below. New or changed text material is indicated by a vertical bar in the margin. An illustration change is indicated by a miniature pointing hand.

### Remove pages

i through vi  
vi.1/(vi.2 blank)  
viii.1/(viii.2 blank)  
ix and x  
x.1/(x.2 blank)  
xi and xii  
-----  
xvii and xviii  
xviii.1/(xviii.2 blank)  
xix through xxi/(xxii blank)  
7-59 and 7-60  
8-41 through 8-44  
-----

### Insert pages

i through vi  
vi.1 and vi.2  
viii.1/(viii.2 blank)  
ix and x  
x.1/(x.2 blank)  
xi and xii  
xii.1/(xii.2 blank)  
xvii and xviii  
xviii. 1 and xviii.2  
xix through xxii  
7-59 and 7-60  
8-41 through 8-44  
8-44.1 through 8-44.7/(8-44.8 blank)

2. Retain this sheet in front of manual for reference purposes.

U R G E N T

TM 55-1520-236-23-2  
C21

By Order of the Secretary of the Army:

Official:

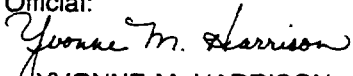
  
YVONNE M. HARRISON  
*Administrative Assistant to the  
Secretary of the Army*  
00964

DENNIS J. REIMER  
*General, United States Army  
Chief of Staff*

**DISTRIBUTION:**

To be distributed in accordance with DA Form 12-31-E, block no. 1149, requirements for  
TM 55-1520-236-23-2.

CHANGE

NO. 20

HEADQUARTERS  
DEPARTMENT OF THE ARMY  
WASHINGTON, D.C., 15 December 1994

Aviation Unit and Intermediate  
Maintenance Manual

ARMY MODEL  
AH-1 P (PROD)  
AH-1E (ECAS)  
AH-1F (MODERNIZED COBRA)  
HELICOPTERS

DISTRIBUTION STATEMENT A: Approved for public release; distribution is unlimited

TM 55-1520-236-23-2,8 May 1980, is changed as follows:

1. Remove and insert pages as indicated below. New or changed text material is indicated by a vertical bar in the margin. An illustration change is indicated by a miniature pointing hand.

Remove pages

V and vi  
vi.1/(vi.2 blank)  
vii and viii  
viii.1/(viii.2 blank)  
ix and x  
x.1/(x.2 blank)  
xi and xii  
xix and xx  
9-15 through 9-18  
9-83 and 9-84  
9-84.1 /(9-84.2 blank)  
9-85 and 9-86  
9-94.1 and 9-94.2  
B-11 and B-12  
B-12.1/(B-12.2 blank)  
B-19 and B-20  
B-25 and B-26  
C-3 and C-4

Insert pages

v and vi  
vi.1/(vi.2 blank)  
vii and viii  
viii.1/(viii.2 blank)  
ix and x  
x.1/(x.2 blank)  
xi and xii  
xix and xx  
9-15 through 9-18  
9-83 and 9-84  
9-84.1 /(9-84.2 blank)  
9-85 and 9-86  
9-94.1 through 9-94.5/(9-94.6 blank)  
B-11 and B-12  
B-12.1 and B-12.2  
B-19 and B-20  
B-25 and B-26  
C-3 and C-4

2. Retain this sheet in front of manual for reference purposes.

TM 55-1520-235-23-2

C20

By Order of the Secretary of the Army:

Official:

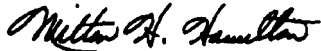

**MILTON H. HAMILTON**  
*Administrative Assistant to the  
Secretary of the Army*

07664

GORDON R. SULLIVAN  
*General, United States Army  
Chief of Staff*

DISTRIBUTION:

To be distributed in accordance with DA Form 12-31-E, block no. 1149, requirements for  
TM 55-1520-236-23-2.



CHANGE  
NO. 19

HEADQUARTERS  
DEPARTMENT OF THE ARMY  
WASHINGTON, D.C., 31 AUGUST 1994

AVIATION UNIT AND INTERMEDIATE  
MAINTENANCE MANUAL

ARMY MODEL  
AH-1P (PROD)  
AH-1E (ECAS)  
AH-1F (MODERNIZED COBRA) HELICOPTERS

DISTRIBUTION STATEMENT A: Approved for public release; distribution is unlimited

TM 55-1520-236-23-2, 8 May 1980, is changed as follows:

1. Remove and insert pages as indicated below. New or changed text material is indicated by a vertical bar in the margin. An illustration change is indicated by a miniature pointing hand.

Remove pages

a and b

i and ii

xv and xvi

xix through xxi/(xxii blank)

7-29 and 7-30

7-35 and 7-36

7-53 through 7-56

7-59 and 7-60

7-135 and 7-136

8-11 through 8-14

8-37 and 8-38

-----

9-13 and 9-14

9-44.1/(9-44.2 blank)

9-45 and 9-46

9-77 and 9-78

-----

Insert pages

a and b

i and ii

xv and xvi

xix through xxi/(xxii blank)

7-29 and 7-30

7-35 and 7-36

7-53 through 7-56

7-59 and 7-60

7-135 and 7-136

8-11 through 8-14

8-37 and 8-38

8-38.1/(8-38.2 blank)

9-13 and 9-14

9-44.1 and 9-44.2

9-45 and 9-46

9-77 and 9-78

9-78.1/(9-78.2 blank)

Remove pages

9-79 and 9-80  
9-80.1/(9-80.2 blank)  
9-81 and 9-82  
9-82.1/(9-82.2 blank)  
9-86.1/(9-86.2 blank)  
9-88.27 and 9-88.28  
9-109 and 9-110  
9-110.1 and 9-110.2  
9-217 and 9-218  
10-3 through 10-6  
10-13 and 10-14  
11-91 and 11-92  
16-31 and 16-32  
16-32.1 and 16-32.2  
16-35 and 16-36  
A-1 through A-3/(A-4 blank)  
B-25 and B-26  
B-31 and B-32  
C-3 and C-4

Insert pages

9-79 and 9-80  
9-80.1/(9-80.2 blank)  
(9-81 blank)/9-82  
9-82.1/(9-82.2 blank)  
9-86.1/(9-86.2 blank)  
9-88.27 and 9-88.28  
9-109 and 9-110  
(9-110.1 blank)/9-110.2  
9-217 and 9-218  
10-3 through 10-6  
10-13 and 10-14  
11-91 and 11-92  
16-31 and 16-32  
16-32.1 and 16-32.2  
16-35 through 16-39/(16-40 blank)  
A-1 through A-3/(A-4 blank)  
B-25 and B-26  
B-31 and B-32  
C-3 and C-4

2. Retain this sheet in front of manual for reference purposes.

By Order of the Secretary of the Army:

Official:

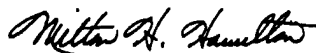

MILTON H. HAMILTON  
Administrative Assistant to the  
Secretary of the Army

07503

GORDON R. SULLIVAN  
General, United States Army  
Chief of Staff

DISTRIBUTION:

To be distributed in accordance with DA Form 12-31-E, block no. 1149, requirements for  
TM 55-1520-236-23-2.

CHANGE  
NO. 18

HEADQUARTERS  
DEPARTMENT OF THE ARMY  
WASHINGTON, D.C., 31 August 1993

AVIATION UNIT AND INTERMEDIATE  
MAINTENANCE MANUAL

ARMY MODEL  
AH-1P (PROD)  
AH-1E (ECAS)  
AH-1F (MODERNIZED COBRA)  
HELICOPTERS

DISTRIBUTION STATEMENT A: Approved for public release; distribution is unlimited.

TM 55-1520-236-23-2, 8 May 1980, is changed as follows:

1. Remove and insert pages as indicated below. New or changed text material is indicated by a vertical bar in the margin. An illustration change is indicated by a miniature pointing hand.

Remove pages

xiii and xiv  
7-9 and 7-10  
7-15 and 7-16  
7-33 and 7-34  
7-37 and 7-38  
7-41 and 7-42  
7-59 and 7-60  
7-109 and 7-110  
8-9 and 8-10  
8-13 and 8-14  
8-25 and 8-26  
8-26.1 through 8-26.5/(8-26.6 blank)  
9-85 and 9-86  
9-91 and 9-92  
-----  
9-93 and 9-94  
9-217 and 9-218  
10-5 and 10-6  
10-13 and 10-14  
10-17 and 10-18  
10-23 through 10-26  
11-28.1 and 11-28.2  
11-29 through 11-34  
11-79 through 11-82  
16-11 and 16-12  
16-19 and 16-20  
16-23 through 16-26  
16-27 and 16-28  
16-31 and 16-32  
17-3 and 17-4  
B-19 and B-20

Insert pages

xiii and xiv  
7-9 and 7-10  
7-15 and 7-16  
7-33 and 7-34  
7-37 and 7-38  
7-41 and 7-42  
7-59 and 7-60  
7-109 and 7-110  
8-9 and 8-10  
8-13 and 8-14  
8-25 and 8-26  
8-26.1 through 8-26.5/(8-26.6 blank)  
9-85 and 9-86  
9-91 and 9-92  
9-92.1 and 9-92.2  
9-93 and 9-94  
9-217 and 9-218  
10-5 and 10-6  
10-13 and 10-14  
10-17 and 10-18  
10-23 through 10-26  
11-28.1 and 11-28.2  
11-29 through 11-34  
11-79 through 11-82  
16-11 and 16-12  
16-19 and 16-20  
16-23 through 16-26  
16-27 and 16-28  
16-31 and 16-32  
17-3 and 17-4  
B-19 and B-20

Remove pages

C-3 and C-4

Insert pages

C-3 and C-4

2. Retain this sheet in front of manual for reference purposes.

By Order of the Secretary of the Army:

Official:

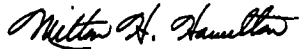

MILTON H. HAMILTON  
*Administrative Assistant to the  
Secretary of the Army*

05088

GORDON R. SULLIVAN  
*General, United States Army  
Chief of Staff*

**DISTRIBUTION:**

To be distributed in accordance with DA Form 12-31-E, block no. 1149, requirements for TM 55-1520-236-23-2.

CHANGE }  
NO. 17 }

HEADQUARTERS  
DEPARTMENT OF THE ARMY  
WASHINGTON, D.C., 30 April 1992

AVIATION UNIT AND INTERMEDIATE  
MAINTENANCE MANUAL

ARMY MODEL  
AH-1P (PROD)  
AH-1E (ECAS)  
AH-1F (MODERNIZED COBRA)  
HELICOPTERS

TM 55-1520-236-23-2, 8 May 1980, is changed as follows:

1. Remove and insert pages as indicated below. New or changed text material is indicated by a vertical bar in the margin. An illustration change is indicated by a miniature pointing hand.

Remove pages	Insert pages
8-51 through 8-53/8-54	8-51 through 8-58/8-54

2. Retain this sheet in front of manual for reference purposes.

By Order of the Secretary of the Army:

GORDON R. SULLIVAN  
*General, United States Army*  
*Chief of Staff*

Official:

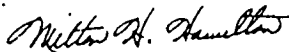
  
MILTON H. HAMILTON  
*Administrative Assistant to the*  
*Secretary of the Army*  
01234

DISTRIBUTION:

To be distributed in accordance with DA Form 12-31-E, block no. 1149, AVUM and AVIM maintenance requirements for TM 55-1520-236-23-2.



CHANGE }  
NO. 16 }

HEADQUARTERS  
DEPARTMENT OF THE ARMY  
WASHINGTON, D.C., 25 February 1991

AVIATION UNIT AND INTERMEDIATE  
MAINTENANCE MANUAL

ARMY MODEL  
AH-1P (PROD)  
AH-1E (ECAS)  
AH-1F (MODERNIZED COBRA)  
HELICOPTERS

TM 55-1520-236-23-2, 8 May 1980, is changed as follows:

1. Remove and insert pages as indicated below. New or changed text materi is indicated by a vertical bar in the margin. An illustration change is indicat by a miniature pointing hand.

Remove pages	Insert pages
Introductory Page	Introductory Page
i through vi	i through vi
---	vi.1/vi.2
vii and viii	vii and viii
---	viii.1/viii.2
ix and x	ix and x
x.1/x.2	x.1/x.2
xi through xvi	xi through xvi
xvi.1/xvi.2	xvi.1/xvi.2
---	xviii.1/xviii.2
xix through xxi/xxii	xix through xxi/xxii
7-31 through 7-34	7-31 through 7-34
7-39 and 7-40	7-39 and 7-40
---	7-40.1/7-40.2
7-41 and 7-42	7-41 and 7-42
7-50.1/7-50.2	7-50.1/7-50.2
7-59 through 7-62	7-59 through 7-62
---	7-68.1 through 7-68.7/7-68.8
7-69 and 7-70	7-69 and 7-70
7-89 and 7-90	7-89 and 7-90
8-5 and 8-6	8-5 and 8-6
8-13 and 8-14	8-13 and 8-14
8-19 through 8-22	8-19 through 8-22
---	8-22.1/8-22.2
8-29 and 8-30	8-29 and 8-30
8-37 and 8-38	8-37 and 8-38
8-47 and 8-48	8-47 and 8-48
9-13 and 9-14	9-13 and 9-14
9-31 and 9-32	9-31 and 9-32
9-43 and 9-44	9-43 and 9-44
9-44.1/9-44.2	9-44.1/9-44.2
9-45 through 9-48	9-45 through 9-48
9-61 and 9-62	9-61 and 9-62
9-67 and 9-68	9-67 and 9-68

Remove pages

9-73 and 9-74  
9-79 and 9-80  
---  
9-81 and 9-82  
---  
9-83 and 9-84  
---  
9-87 and 9-88  
9-88.7 through 9-88.20  
9-88.23 through 9-88.28  
9-88.31 through 9-88.36  
9-88.39 and 9-88.40  
9-95 and 9-96  
9-109 and 9-110  
---  
9-117 and 9-118  
10-1 and 10-2  
---  
10-3 through 10-12  
10-13 through 10-16  
11-15 and 11-16  
11-43 and 11-44  
11-101 and 11-102  
---  
13-17 and 13-18  
16-2.1/16-2.2  
16-11 and 16-12  
16-19 and 16-20  
16-27 and 16-28  
16-31 and 16-32  
---  
17-1 and 17-2  
17-5 and 17-6  
A-1 and A-2  
B-3 and B-4  
B-11 and B-12  
---  
B-13 and B-14  
---  
B-17 through B-20  
B-27 and B-28  
---  
B-35/B-36  
C-3 and C-4  
Cover 1/2

Insert pages

9-73 and 9-74  
9-79 and 9-80  
9-80.1/9-80.2  
9-81 and 9-82  
9-82.1/9-82.2  
9-83 and 9-84  
9-86.1/9-86.2  
9-87 and 9-88  
9-88.7 through 9-88.20  
9-88.23 through 9-88.28  
9-88.31 through 9-88.36  
9-88.39 and 9-88.40  
9-95 and 9-96  
9-109 and 9-110  
9-110.1 and 9-110.2  
9-117 and 9-118  
10-1 and 10-2  
10-2.1/10-2.2  
10-3 through 10-12  
10-13 through 10-16  
11-15 and 11-16  
11-43 and 11-44  
11-101 and 11-102  
12-5 through 12-13/12-14  
13-17 and 13-18  
16-2.1/16-2.2  
16-11 and 16-12  
16-19 and 16-20  
16-27 and 16-28  
16-31 and 16-32  
16-32.1 and 16-32.2  
17-1 and 17-2  
17-5 and 17-6  
A-1 and A-2  
B-3 and B-4  
B-11 and B-12  
B-12.1/B-12.2  
B-13 and B-14  
B-14.1/B-14.2  
B-17 through B-20  
B-27 and B-28  
B-28.1/B-28.2  
B-35/B-36  
C-3 and C-4  
Cover 1/2

2. Retain these sheets in front of manual for reference purposes.



**By Order of the Secretary of the Army:**

**Official:**

**THOMAS F. SIKORA**  
*Brigadier General, United States Army*  
*The Adjutant General*

**CARLE E. VUONO**  
*General, United States Army*  
*Chief of Staff*

**DISTRIBUTION:**

To be distributed in accordance with DA Form 12-31-E, block no. 1149, AVUM and AVIM maintenance requirements for TM 55-1520-236-23-2.



CHANGE }  
No. 15 }

HEADQUARTERS  
DEPARTMENT OF THE ARMY  
WASHINGTON, D.C., 1 June 1990

AVIATION UNIT AND INTERMEDIATE  
MAINTENANCE MANUAL

ARMY MODEL  
AH-1P (PROD)  
AH-1E (ECAS)  
AH-1F (MODERNIZED COBRA)  
HELICOPTERS

TM 55-1520-236-23-2, 8 May 1980, is changed as follows:

1. Remove and insert pages as indicated below. New or changed text material is indicated by a vertical bar in the margin. An illustration change is indicated by a miniature pointing hand.

Remove pages

Index  
xv and xvi  
- - -  
xix and xx  
9-193 and 9-194  
- - -  
9-195 through 9-198  
- - -  
9-199 through 9-202  
16-1 and 16-2  
- - -

Insert pages

Index  
xv and xvi  
xvi.1/xvi.2  
xix and xx  
9-193 and 9-194  
9-194.1/9-194.2  
9-195 through 9-198  
9-198.1/9-198.2  
9-199 through 9-202  
16-1 and 16-2  
16-2.1/16-2.2

2. Retain this sheet in front of manual for reference purposes.

By Order of the Secretary of the Army:

Official:

**WILLIAM J. MEEHAN II**  
*Brigadier General, United States Army*  
*The Adjutant General*

**CARLE. VUONO**  
*General, United States Army*  
*Chief of Staff*

DISTRIBUTION:

To be distributed in accordance with DA Form 12-31, AVUM and AVIM Maintenance requirements for AH-1F and AH-1P/E Helicopter, Attack.



C-9 C19

CHANGE }  
NO. 14 }HEADQUARTERS  
DEPARTMENT OF THE ARMY  
WASHINGTON, D.C., 13 MARCH 1989Aviation Unit and Intermediate  
Maintenance ManualARMY MODEL  
AH-1P (PROD)  
AH-1E (ECAS)  
AH-1F (MODERNIZED COBRA)  
HELICOPTERS

TM 55-1520-236-23-2, 8 May 1980, is changed as follows:

1. Remove and insert pages as indicated below. New or changed text material is indicated by a vertical bar in the margin. An illustration change is indicated by a miniature pointing hand.

## Remove pages

a and b  
9-123 and 9-124  
9-141 and 9-142  
9-163 and 9-164  
9-185 and 9-186  
9-207 and 9-208

## Insert pages

a and b  
9-123 and 9-124  
9-141 and 9-142  
9-163 and 9-164  
9-185 and 9-186  
9-207 and 9-208

2. Retain this sheet in front of manual for reference purposes.

**By Order of the Secretary of the Army:**

**CARL E. VUONO**  
*General, United States Army*  
*Chief of Staff*

**Official:**

**WILLIAM J. MEEHAN II**  
*Brigadier General, United States Army*  
*The Adjutant General*

## DISTRIBUTION:

To be distributed in accordance with DA Form 12-31, AVUM and AVIM Maintenance requirements for AH-1F and AH-1P/E Helicopter, Attack.



CHANGE }  
No. 13 }

HEADQUARTERS  
DEPARTMENT OF THE ARMY  
WASHINGTON, D.C., 27 February 1989

Aviation Unit and Intermediate  
Maintenance Manual

ARMY MODEL  
AH-1P (PROD)  
AH-1E (ECAS)  
AH-1F (MODERNIZED COBRA)  
HELICOPTERS

TM 55-1520-236-23-2, 8 May 1980, is changed as follows:

1. Remove and insert pages as indicated below. New or changed text material is indicated by a vertical bar in the margin. An illustration change is indicated by a miniature pointing hand.

Remove pages	Insert pages
/ xi and xii	xi and xii
/ - - -	xii.1/xii.2
xix through xxi/xxii	xix through xxi/xxii
9-79 and 9-80	9-79 and 9-80
9-83 through 9-88	9-83 through 9-88
/ - - -	9-88.1 through 9-88.40

2. Retain this sheet in front of manual for reference purposes.

By Order of the Secretary of the Army:

**CARL E. VUONO**  
*General, United States Army*  
*Chief of Staff*

Official:

**WILLIAM J. MEEHAN II**  
*Brigadier General, United States Army*  
*The Adjutant General*

DISTRIBUTION:

To be distributed in accordance with DA Form 12-31, AVUM and AVIM Maintenance Requirements for AH-1F and AH-1P/E Helicopter, Attack.





CHANGE }  
NO. 12 }

HEADQUARTERS  
DEPARTMENT OF THE ARMY  
WASHINGTON, D.C., 9 December 1988

Aviation Unit and Intermediate  
Maintenance Manual

ARMY MODEL  
AH-1P (PROD)  
AH-1E (ECAS)  
AH-1F (MODERNIZED COBRA)  
HELICOPTERS

TM 55-1520-236-23-2, 8 May 1980, is changed as follows:

1. Remove and insert pages as indicated below. New or changed text material is indicated by a vertical bar in the margin. An illustration change is indicated by a miniature pointing hand.

Remove pages

c and d  
- - -  
7-13 and 7-14  
7-55 and 7-56  
7-69 and 7-70  
7-137 and 7-138  
9-44.1/9-44.2  
9-49 and 9-50  
9-137 and 9-138  
- - -  
9-139 and 9-140  
9-171 and 9-172  
- - -  
9-203 and 9-204  
10-7 and 10-8  
10-11 and 10-12  
10-15 and 10-16  
10-19 and 10-20  
11-5 and 11-6  
11-15 and 11-16  
11-21 and 11-22  
- - -  
11-59 and 11-60  
11-87 and 11-88  
11-123/11-124  
13-12.1/13-12.2  
13-13 and 13-14  
13-29 and 13-30  
16-35/16-36

Insert pages

c and d  
e/f  
7-13 and 7-14  
7-55 and 7-56  
7-69 and 7-70  
7-137 and 7-138  
9-44.1/9-44.2  
9-49 and 9-50  
9-137 and 9-138  
9-138.1/9-138.2  
9-139 and 9-140  
9-171 and 9-172  
9-172.1/9-172.2  
9-203 and 9-204  
10-7 and 10-8  
10-11 and 10-12  
10-15 and 10-16  
10-19 and 10-20  
11-5 and 11-6  
11-15 and 11-16  
11-21 and 11-22  
11-22.1/11-22.2  
11-59 and 11-60  
11-87 and 11-88  
11-123/11-124  
13-12.1 and 13-12.2  
13-13 and 13-14  
13-29 and 13-30  
16-35 and 16-36

17-1 and 17-2  
A-1 and A-2  
C-3 and C-4

17-1 and 17-2  
A-1 and A-2  
C-3 and C-4

2. Retain this sheet in front of manual for reference purposes.

By Order of the Secretary of the Army:

**CARL E. VUONO**  
*General, United States Army*  
*Chief of Staff*

Official:

**WILLIAM J. MEEHAN II**  
*Brigadier General, United States Army*  
*The Adjutant General*

**DISTRIBUTION:**

To be distributed in accordance with DA Form 12-31, AVUM and AVIM requirements for AH-1F and AH-1P/E Attack Helicopter.

CHANGE }  
 NO. 11 }

HEADQUARTERS  
 DEPARTMENT OF THE ARMY  
 WASHINGTON, D.C., 6 October 1988

Aviation Unit and Intermediate  
 Maintenance Manual

ARMY MODEL  
 AH-1P (PROD)  
 AH-1E (ECAS)  
 AH-1F (MODERNIZED COBRA)  
 HELICOPTERS

TM 55-1520-236-23-2, 8 May 1980, is changed as follows:

1. Remove and insert pages as indicated below. New or changed text material is indicated by a vertical bar in the margin. An illustration change is indicated by a miniature pointing hand.

Remove pages	Insert pages
iii through xxi/xxii	iii through xxii
7-57 and 7-58	7-57 and 7-58
7-59 and 7-60	7-59 and 7-60
9-1 through 9-4	9-1 through 9-4
9-43 and 9-44	9-43 and 9-44
9-44.1/9-44.2	9-44.1/9-44.2
9-121 and 9-122	9-121 and 9-122
-----	9-122.1 through 9-122.24
9-155 and 9-156	9-155 and 9-156
-----	9-156.1 through 9-156.25/9-156.26
10-7 and 10-8	10-7 and 10-8
10-11 through 10-12.2	10-11 through 10-12.2
11-5 through 11-8	11-5 through 11-8
-----	11-28.1 and 11-28.2
11-29 through 11-34	11-29 through 11-34
11-79 and 11-80	11-79 and 11-80
11-101 and 11-102	11-101 and 11-102
13-13 and 13-14	13-13 and 13-14
13-27 and 13-28	13-27 and 13-28
B-15 and B-16	B-15 and B-16

2. Retain this sheet in front of manual for reference purposes.

**By Order of the Secretary of the Army:**

**CARL E. VUONO**  
*General, United States Army*  
*Chief of Staff*

**Official:**

**WILLIAM J. MEEHAN II**  
*Brigadier General, United States Army*  
*The Adjutant General*

**DISTRIBUTION:**

To be distributed in accordance with DA Form 12-31, AVUM and AVIM requirements for AH-1F and AH-1P/E Attack Helicopter.

CHANGE }  
NO. 10 }

HEADQUARTERS  
DEPARTMENT OF THE ARMY  
WASHINGTON, D.C., 31 August 1987

Aviation Unit and Intermediate  
Maintenance Manual

ARMY MODEL  
AH-1P (PROD)  
AH-1E (ECAS)  
AH-1F (MODERNIZED COBRA)  
HELICOPTERS

TM 55-1520-236-23-2, 8 May 1980, is changed as follows:

1. Title is changed as shown above.
2. Remove and insert pages as indicated below. New or changed text material is indicated by a vertical bar in the margin. An illustration change is indicated by a miniature pointing hand.

Remove pages

7-47 and 7-48  
7-55 and 7-56  
8-11 through 8-14  
8-17 through 8-22  
9-25 and 9-26  
9-44.1/(9-44.2)  
9-45 and 9-46  
9-49 and 9-50  
9-67 and 9-68  
9-75 through 9-80  
- - -  
9-97 and 9-98  
- - -  
9-99 through 9-102  
9-119 and 9-120  
10-7 through 10-10  
11-5 and 11-6  
11-59 and 11-60  
11-89 and 11-90  
13-13 and 13-14  
A-1 and A-2  
B-15 and B-16  
B-35/(B-36)  
C-3 and C-4

Insert pages

7-47 and 7-48  
7-55 and 7-56  
8-11 through 8-14  
8-17 through 8-22  
9-25 and 9-26  
9-44.1/(9-44.2)  
9-45 and 9-46  
9-49 and 9-50  
9-67 and 9-68  
9-75 through 9-80  
9-94.1 and 9-94.2  
9-97 and 9-98  
9-98.1 and 9-98.2  
9-99 through 9-102  
9-119 and 9-120  
10-7 through 10-10  
11-5 and 11-6  
11-59 and 11-60  
11-89 and 11-90  
13-13 and 13-14  
A-1 and A-2  
B-15 and B-16  
B-35/(B-36)  
C-3 and C-4

3. Retain these sheets in front of manual for reference purposes.

**By Order of the Secretary of the Army:**

**CARL E. VUONO**  
*General, United States Army*  
*Chief of Staff*

**Official:**

**R. L. DILWORTH**  
*Brigadier General, United States Army*  
*The Adjutant General*

**DISTRIBUTION:**

To be distributed in accordance with DA Form 12-31, AVUM and AVIM requirements for AH-1F and AH-1P/E Attack Helicopter.

CHANGE }  
 NO. 9 }

HEADQUARTERS  
 DEPARTMENT OF THE ARMY  
 WASHINGTON, D.C., 7 April 1987

Aviation Unit and Intermediate  
 Maintenance Manual

ARMY MODEL  
 AH-1S (PROD)  
 AH-1S (ECAS)  
 AH-1S (MODERNIZED COBRA)  
 HELICOPTERS

TM 55-1520-236-23-2, 8 May 1980, is changed as follows:

1. Remove and insert pages as indicated below. New or changed text material is indicated by a vertical bar in the margin. An illustration change is indicated by a miniature pointing hand.

Remove pages	Insert pages
7-135 and 7-136	7-135 and 7-136
8-43 through 8-46	8-43 through 8-46
9-41 and 9-42	9-41 and 9-42
9-81 and 9-82	9-81 and 9-82
9-185 and 9-186	9-185 and 9-186
9-203 and 9-204	9-203 and 9-204
10-15 and 10-16	10-15 and 10-16
10-25 and 10-26	10-25 and 10-26
11-21 and 11-22	11-21 and 11-22
11-31 through 11-34	11-31 through 11-34
-----	11-38.1/11-38.2
11-39 and 11-40	11-39 and 11-40
11-59 and 11-60	11-59 and 11-60
11-74.1 and 11-74.2	11-74.1 and 11-74.2
13-25 and 13-26	13-25 and 13-26
16-9 and 16-10	16-9 and 16-10
-----	16-10.1/16-10.2
16-11 and 16-12	16-11 and 16-12
16-27 and 16-28	16-27 and 16-28
16-31 and 16-32	16-31 and 16-32
B-15 and B-16	B-15 and B-16

2. Retain this sheet in front of manual for reference purposes.

**By Order of the Secretary of the Army:**

**JOHN A. WICKHAM, JR.**  
*General, United States Army*  
*Chief of Staff*

**Official:**

**R. L. DILWORTH**  
*Brigadier General, United States Army*  
*The Adjutant General*

**DISTRIBUTION:**

To be distributed in accordance with DA Form 12-31, AVIM and AVUM requirements for AH-1F and AH-1P/E Attack Helicopter.



HEADQUARTERS  
DEPARTMENT OF THE ARMY  
WASHINGTON, D.C., 29 October 1986

CHANGE }  
NO. 8 }

Aviation Unit and Intermediate  
Maintenance Manual

ARMY MODEL  
AH-1S (PROD)  
AH-1S (ECAS)  
AH-1S (MODERNIZED COBRA)  
HELICOPTERS

TM 55-1520-236-23-2, 8 May 1980, is changed as follows:

1. Remove and insert pages as indicated below. New or changed text material is indicated by a vertical bar in the margin. An illustration change is indicated by a miniature pointing hand.

Remove pages	Insert pages
7-33 and 7-34	7-33 and 7-34
7-51 and 7-52	7-51 and 7-52
7-57 and 7-58	7-57 and 7-58
9-67 and 9-68	9-67 and 9-68
9-83 and 9-84	9-83 and 9-84
9-89 and 9-90	9-89 and 9-90
10-11 and 10-12	10-11 and 10-12
-----	10-12.1 thru 10-12.3/10-12.4
10-17 and 10-18	10-17 and 10-18
11-21 and 11-22	11-21 and 11-22
11-81 and 11-82	11-81 and 11-82
-----	13-12.1/13-12.2
13-13 and 13-14	13-13 and 13-14
16-19 thru 16-20.1/16-20.2	16-19 thru 16-20.1/16-20.2
A-1 thru A-3/A-4	A-1 thru A-3/A-4
B-1 and B-2	B-1 and B-2
C-3 and C-4	C-3 and C-4

2. Retain this sheet in front of manual for reference purposes.

TM 55-1520-236-23-2

C 8

By Order of the Secretary of the Army:

**JOHN A. WICKHAM, JR.**  
*General, United States Army*  
*Chief of Staff*

Official:

**R. L. DILWORTH**  
*Brigadier General, United States Army*  
*The Adjutant General*

DISTRIBUTION:

To be distributed in accordance with DA Form 12-31, AVIM and AVUM requirements for AH-1S Helicopter, Attack (MOD COBRA), and AH-1S Helicopter, Attack (PROD) (ECAS).

CHANGE }  
NO. 7 }

HEADQUARTERS  
DEPARTMENT OF THE ARMY  
WASHINGTON, D.C., 2 July 1985

Aviation Unit and Intermediate  
Maintenance Manual

ARMY MODEL  
AH-1S(PROD)  
AH-1S(ECAS)  
AH-1S(MODERNIZED COBRA)  
HELICOPTERS

CHANGES 5 AND 6 WERE DATED OUT OF SEQUENCE.  
THESE CHANGES ARE GOOD AND SHOULD BE USED.

TM 55-1520-236-23-2, 8 May 1980, is changed as follows:

1. Remove and insert pages as indicated below. New or changed text material is indicated by a vertical bar in the margin. An illustration change is indicated by a miniature pointing hand.

Remove pages

✓ 7-135 and 7-136  
✓ 8-19 and 8-20  
8-41 and 8-42  
8-45 and 8-46  
9-33 and 9-34  
9-43 and 9-44  
9-44.1/9-44.2  
9-83 and 9-84  
10-9 and 10-10  
11-27 through 11-30  
11-59 and 11-60  
11-67 and 11-68  
11-75 through 11-78  
11-81 and 11-82  
13-19 and 13-20  
13-25 and 13-26  
13-33 and 13-34  
16-23 and 16-24  
B-25 and B-26

Insert. pages

7-135 and 7-136  
8-19 and 8-20  
8-41 and 8-42  
8-45 and 8-46  
9-33 and 9-34  
9-43 and 9-44  
9-44.1/9-44.2  
9-83 and 9-84  
10-9 and 10-10  
11-27 through 11-30  
11-59 and 11-60  
11-67 and 11-68  
11-75 through 11-78  
11-81 and 11-82  
13-19 and 13-20  
13-25 and 13-26  
13-33 and 13-34  
16-23 and 16-24  
B-25 and B-26

2. Retain this sheet in front of manual for reference purposes.

**By Order of the Secretary of the Army:**

**Official:**

**JOHN A. WICKHAM, JR.**  
*General, United States Army*  
*Chief of Staff*

**DONALD J. DELANDRO**  
*Brigadier General, United States Army*  
*The Adjutant General*

**DISTRIBUTION:**

To be distributed in accordance with DA Form 12-31, Organizational, Direct Support and General Support Maintenance requirements for AH-1S Helicopter, Attack (MOD COBRA), and AH-1S Helicopter, Attack (PROD) (ECAS).

# URGENT

NOTICE: THIS CHANGE HAS BEEN PRINTED AND DISTRIBUTED OUT OF SEQUENCE. IT SHOULD BE INSERTED IN THE MANUAL AND USED. UPON RECEIPT OF THE EARLIER SEQUENCE CHANGE INSURE A MORE CURRENT CHANGE PAGE IS NOT REPLACED WITH A LESS CURRENT PAGE.

TM 55-1520-236-23-2

CHANGE }  
NO. 6 }

HEADQUARTERS  
DEPARTMENT OF THE ARMY  
WASHINGTON, D.C., 4 December 1984

## Aviation Unit and Intermediate Maintenance Manual

ARMY MODEL  
AH-1S(PROD)  
AH-1S(ECAS)  
AH-1S(MODERNIZED COBRA)  
HELICOPTERS

TM 55-1520-236-23-2, 8 May 1980, is changed as follows:

1. Remove and insert pages as indicated below. New or changed text material is indicated by a vertical bar in the margin. An illustration change is indicated by a miniature pointing hand.

Remove pages

Insert pages

c/d

c and d

2. Retain this sheet in front of manual for reference purposes.

**By Order of the Secretary of the Army:**

**JOHN A. WICKHAM, JR.**  
*General, United States Army*  
*Chief of Staff*

**Official:**

**DONALD J. DELANDRO**  
*Brigadier General, United States Army*  
*The Adjutant General*

**DISTRIBUTION:**

To be distributed in accordance with DA Form 12-31, Organizational, Direct Support, and General Support Maintenance requirements for AH-1S(MOD COBRA) and AH-1S(PROD)(ECAS) aircraft.

# URGENT



CHANGE }  
NO. 5 }HEADQUARTERS  
DEPARTMENT OF THE ARMY  
WASHINGTON, D.C., 7 January 1985Aviation Unit and Intermediate  
Maintenance ManualARMY MODEL  
AH-1S (PROD)  
AH-1S (ECAS)  
AH-1S (MODERNIZED COBRA)  
HELICOPTERS

TM 55-1520-236-23-2, 8 May 1980, is changed as follows:

1. Remove and insert pages as indicated below. New or changed text material is indicated by a vertical bar in the margin. An illustration change is indicated by a miniature pointing hand.

Remove pages	Insert pages
iii and iv	iii and iv
xiii and xiv	xiii and xiv
7-13 and 7-14	7-13 and 7-14
7-17 and 7-18	7-17 and 7-18
7-27 and 7-28	7-27 and 7-28
7-39 and 7-40	7-39 and 7-40
7-49 and 7-50	7-49 and 7-50
7-50.1/7-50.2	7-50.1/7-50.2
7-51 and 7-52	7-51 and 7-52
7-55 through 7-58	7-55 through 7-58
7-59 through 7-62	7-59 through 7-62
7-65 and 7-66	7-65 and 7-66
7-117 and 7-118	7-117 and 7-118
7-133 and 7-134	7-133 and 7-134
---	7-134.1/7-134.2
7-137 through 7-140	7-137 through 7-140
8-11 and 8-12	8-11 and 8-12
8-23 and 8-24	8-23 and 8-24
---	8-24.1/8-24.2
8-25 and 8-26	8-25 and 8-26
---	8-26.1 through 8-26.5/8-26.6
8-27 through 8-30	8-27 through 8-30
8-33 through 8-38	8-33 through 8-38
8-45 and 8-46	8-45 and 8-46
9-44.1/9-44.2	9-44.1/9-44.2
9-45 and 9-46	9-45 and 9-46
9-83 and 9-84	9-83 and 9-84
9-99 and 9-100	9-99 and 9-100
10-1 and 10-2	10-1 and 10-2
10-15 through 10-20	10-15 through 10-20
10-25 and 10-26	10-25 and 10-26
11-3 through 11-6	11-3 through 11-6
11-13 and 11-14	11-13 and 11-14
11-21 and 11-22	11-21 and 11-22
11-29 through 11-32	11-29 through 11-32

Remove pages

11-35 through 11-38  
 11-43 and 11-44  
 11-55 and 11-56  
 ---  
 11-59 and 11-60  
 11-65 and 11-66  
 ---  
 11-73 and 11-74  
 ---  
 11-75 through 11-78  
 11-81 and 11-82  
 11-91 and 11-92  
 ---  
 11-117 and 11-118  
 13-27 through 13-30  
 16-19 and 16-20  
 ---  
 16-25 and 16-26  
 ---  
 16-33 and 16-34  
 B-17 through B-20  
 B-25 and B-26  
 B-31 and B-32  
 C-3 and C-4

Insert pages

11-35 through 11-38  
 11-43 and 11-44  
 11-55 and 11-56  
 11-56.1/11-56.2  
 11-59 and 11-60  
 11-65 and 11-66  
 11-66.1/11-66.2  
 11-73 and 11-74  
 11-74.1 and 11-74.2  
 11-75 through 11-78  
 11-81 and 11-82  
 11-91 and 11-92  
 11-92.1/11-92.2  
 11-117 and 11-118  
 13-27 through 13-30  
 16-19 and 16-20  
 16-20.1/16-20.2  
 16-25 and 16-26  
 16-26.1/16-26.2  
 16-33 and 16-34  
 B-17 through B-20  
 B-25 and B-26  
 B-31 and B-32  
 C-3 and C-4

2. Retain this sheet in front of manual for reference purposes.

**By Order of the Secretary of the Army:**

**JOHN A. WICKHAM, JR.**  
*General, United States Army*  
*Chief of Staff*

**Official:**

**DONALD J. DELANDRO**  
*Brigadier General, United States Army*  
*The Adjutant General*

**DISTRIBUTION:**

To be distributed in accordance with DA Form 12-31, Organizational, Direct Support and General Support Maintenance requirements for AH-1S(MOD COBRA) and AH-1S(PROD) (ECAS) aircraft.



# URGENT

NOTICE: THIS CHANGE HAS BEEN PRINTED AND DISTRIBUTED OUT OF SEQUENCE. IT SHOULD BE INSERTED IN THE MANUAL AND USED. UPON RECEIPT OF THE EARLIER SEQUENCED CHANGE INSURE A MORE CURRENT CHANGE PAGE IS NOT REPLACED WITH A LESS CURRENT PAGE.

TM 55-1520-236-23-2  
C 4

CHANGE }  
NO. 4 }

HEADQUARTERS  
DEPARTMENT OF THE ARMY  
WASHINGTON, D.C., 17 October 1983

Aviation Unit and Intermediate  
Maintenance Manual

ARMY MODEL  
AH-1S (PROD)  
AH-1S (ECAS)  
AH-1S (MODERNIZED COBRA)  
HELICOPTERS

TM 55-1520-236-23-2, 8 May 1980, is changed as follows:

1. Remove and insert pages as indicated below.

	Remove pages	Insert pages
Chapter 11	11-55 and 11-56	11-55 and 11-56

2. New or changed text material is indicated by a vertical bar in the margin. An illustration change is indicated by a miniature pointing hand.

3. Retain this sheet in front of manual for reference purposes.

**By Order of the Secretary of the Army:**

**JOHN A. WICKHAM, JR.**  
*General, United States Army*  
*Chief of Staff*

**Official:**

**ROBERT M. JOYCE**  
*Major General, United States Army*  
*The Adjutant General*

**DISTRIBUTION:**

To be distributed in accordance with DA Form 12-31, Organizational Maintenance requirements for AH-1S (PROD) aircraft.

# URGENT



CHANGE }  
No. 3 }HEADQUARTERS  
DEPARTMENT OF THE ARMY  
WASHINGTON, D. C., 7 October 1983Aviation Unit and Intermediate  
Maintenance ManualARMY MODEL  
AH-1S (PROD)  
AH-1S (ECAS)  
AH-1S (MODERNIZED COBRA)  
HELICOPTERS

TM 55-1520-236-23-2, 8 May 1980, is changed as follows:

## NOTICE

When the following list of changes on TM 55-1520-236-23-Series manuals are received and incorporated into manuals they will supersede the TM 55-1520-239-23-Series manuals.

TM 55-1520-236-23-1, Changes 1 through 13  
 TM 55-1520-236-23-2, Changes 1 through 3  
 TM 55-1520-236-23-3, Changes 1 and 2  
 TM 55-1520-236-23-4, Changes 1 and 2

## 1. Remove and insert pages as indicated below.

	Remove pages	Insert pages
Chapter 7	7-7 and 7-8	7-7 and 7-8
	7-13 and 7-14	7-13 and 7-14
	7-45 and 7-46	7-45 and 7-46
	7-57 and 7-58	7-57 thru 7-58.1/7-58.2
	7-63 and 7-64	7-63 and 7-64
	7-75 and 7-76	7-75 and 7-76
	7-109 and 7-110	7-109 and 7-110
	7-117 thru 7-120	7-117 thru 7-120
	7-127 and 7-128	7-127 and 7-128
	7-143 and 7-144	7-143 and 7-144
	Chapter 8	8-17 and 8-18
8-25 and 8-26		8-25 and 8-26
Chapter 9	9-31 and 9-32	9-31 and 9-32
	9-45 and 9-46	9-45 and 9-46
	9-85 and 9-86	9-85 and 9-86
	9-113 and 9-114	9-113 and 9-114
	9-185 and 9-186	9-185 and 9-186
	9-189 and 9-190	9-189 and 9-190
	9-201 and 9-202	9-201 and 9-202
	9-205 and 9-206	9-205 and 9-206
	9-213 and 9-214	9-213 and 9-214
	9-217 and 9-218	9-217 and 9-218

	Remove pages	Insert pages
Chapter 10	10-7 and 10-8 10-19 and 10-20	10-7 and 10-8 10-19 and 10-20
Chapter 11	11-1 and 11-2 11-29 and 11-30 11-43 and 11-44 11-55 and 11-56 11-59 and 11-60 11-63 and 11-64 11-77 and 11-78 11-91 thru 11-94	11-1 and 11-2 11-29 and 11-30 11-43 and 11-44 11-55 and 11-56 11-59 and 11-60 11-63 and 11-64 11-77 and 11-78 11-91 thru 11-94
Chapter 13	13-3 and 13-4 13-17 and 13-18	13-3 and 13-4 13-17 thru 13-18.1/13-18.2
Chapter 17	17-5 and 17-6	17-5 and 17-6
Appendix A	A-1 and A-2	A-1 and A-2
Appendix B	B-15 and B-16 B-19 and B-20 B-33 thru B-35/B-36	B-15 and B-16 B-19 and B-20 B-33 thru B-35/B-36
Figure C-1	C-3 and C-4	C-3 and C-4

2. New or changed text material is indicated by a vertical bar in the margin. An illustration change is indicated by a miniature pointing hand.

3. Retain this sheet in front of manual for reference purposes.

By Order of the Secretary of the Army:

**JOHN A. WICKHAM, JR.**  
*General, United States Army*  
*Chief of Staff*

Official:

**ROBERT M. JOYCE**  
*Major General, United States Army*  
*The Adjutant General*

**DISTRIBUTION:**

To be distributed in accordance with DA Form 12-31, Organizational Maintenance requirements for AH-1S (PROD) aircraft.

CHANGE }  
NO. 2 }

HEADQUARTERS  
DEPARTMENT OF THE ARMY  
WASHINGTON, D.C., 23 September 1982

Aviation Unit and Intermediate  
Maintenance Manual

ARMY MODEL  
AH-1S (PROD)  
AH-1S (ECAS)  
AH-1S (MODERNIZED COBRA)  
HELICOPTERS

TM 55-1520-236-23-2, 8 May 1980, is changed as follows:

1. Remove and insert pages as indicated below.

	Remove pages	Insert pages
Table of Contents	i thru iii/iv	i thru xxi/xxii
Chapter 7	7-17 and 7-18 7-47 thru 7-50 7-53 thru 7-56 7-123 and 7-124	7-17 and 7-18 7-47 thru 7-50.1/7-50.2 7-53 thru 7-56 7-123 and 7-124
Chapter 9	9-43 and 9-44 9-61 thru 9-64 9-67 and 9-68 9-71 and 9-72 9-117 and 9-118 9-173 and 9-174 9-205 and 9-206	9-43 thru 9-44.1/9-44.2 9-61 thru 9-64 9-67 and 9-68 9-71 and 9-72 9-117 and 9-118 9-173 and 9-174 9-205 and 9-206
Chapter 11	11-3 and 11-4	11-3 and 11-4
Chapter 13	13-21 thru 13-24	13-21 thru 13-24

2. New or changed text material is indicated by a vertical bar in the margin. An illustration change is indicated by a miniature pointing hand.

3. Retain this sheet in front of manual for reference purposes.

**By Order of the Secretary of the Army:**

**E. C. MEYER**  
*General, United States Army*  
*Chief of Staff*

Official:

**ROBERT M. JOYCE**  
*Major General, United States Army*  
*The Adjutant General*

**DISTRIBUTION:**

To be distributed in accordance with DA Form 12-31, Organizational Maintenance Requirements for AH-1S (PROD) aircraft.



CHANGE }  
No. 1 }

HEADQUARTERS  
DEPARTMENT OF THE ARMY  
WASHINGTON, D.C., 22 October 1980

AVIATION UNIT AND INTERMEDIATE  
MAINTENANCE MANUAL

ARMY MODEL  
AH-1S (PROD)  
AH-1S (ECAS)  
AH-1S (MODERNIZED COBRA)  
HELICOPTERS

TM 55-1520-236-23-2, 8 May 1980, is changed as follows:

1. Remove and insert pages as indicated below.

	Remove pages	Insert pages
Appendix B	B-11 and B-12 B-15 thru B-20 B-23 thru B-26 B-35/B-36	B-11 and B-12 B-15 thru B-20 B-23 thru B-26 B-35/B-36

2. New or changed text material is indicated by a vertical bar in the margin. An illustration change is indicated by a miniature pointing hand.
3. Retain this sheet in front of manual for reference purposes.

By Order of the Secretary of the Army:

Official:

**E. C. MEYER**  
*General, United States Army*  
*Chief of Staff*

**J. C. PENNINGTON**  
*Major General, United States Army*  
*The Adjutant General*

DISTRIBUTION:

To be distributed in accordance with DA Form 12-31, Organizational Maintenance requirements for AH-1S (PROD) aircraft.





TECHNICAL MANUAL

No. 55-1520-236-23-2

HEADQUARTERS  
DEPARTMENT OF THE ARMY  
WASHINGTON, D.C., 8 May 1980

Aviation Unit and Intermediate  
Maintenance Manual

ARMY MODEL  
AH-1P (PROD)  
AH-1E (ECAS)  
AH-1F (MODERNIZED COBRA)

HELICOPTERS

NOTE

This manual is printed in five volumes, as follows:

TM 55-1520-236-23-1, consisting of Table of Contents, Preface Chapters 1 through 6.

TM 55-1520-236-23-2, consisting of Table of Contents. Chapters 7 through 17. Appendix A through C.

TM 55-1520-236-23-3, consisting of Table of Contents, Appendix D through G, and Index.

TM 55-1520-236-23-4, consisting of Table of Contents, FO-1 through FO-142.

TM 55-1520-236-23-5, consisting of Table of Contents, FO-143 (Sheet 1 of 28 through Sheet 28 of 28) through FO-145.

The Preface, Appendices and Index are applicable to all volumes.

\*This manual together with TM 55-1520-236-23-1, 8 May 1980, TM 55-1529-236-2.3-3 8 May 1980, TM 55-1520-236-23-4, 8 May 1980, and TM 55-1520-236-23-5, 31 July 1990, supersedes TM 55-1520-236-23-1, 30 June 1977 and TM 55-1520-236-23-2, 30 June 1977.



**WARNING**

Personnel performing operations, procedures, and practices which are included or implied in this technical manual shall observe the following warnings. Disregard of these warnings and precautionary information can cause serious injury, or death.

Warnings, cautions, and notes are used to emphasize important and critical instructions and shall be used for the following conditions:

**STARTING ENGINE**

Starting and Operation  
of the helicopter will be performed only by  
authorized personnel in accordance with AR 95-1.

**HIGH VOLTAGE**

The helicopter should be electrically grounded when parked.  
Turn off all power switches before making electrical connections or disconnections.  
Serious burns and electrical shock can result from contact  
with exposed electrical wires or connectors.

**LASER LIGHT**

The AIM-1/EXL laser beam is dangerous and can cause blindness if it enters the eye either directly or reflected from a shiny surface. Ensure that the laser protective cover is kept over the emitter and that the AIM power switch is off at all times when the laser is not in use. The laser shall be used only in controlled areas by qualified personnel. Night goggles are required during operation and boresight procedures.

### **RADIATION HAZARD**

Self-luminous dials contain radioactive materials.

If such an instrument is broken or becomes unsealed, avoid personal contact. Use forceps or gloves made of rubber or polyethylene to pick up contaminated material.

Place material and gloves in a plastic bag.

Seal bag and dispose of it as radioactive waste in accordance with AR 755-15 and TM 3-261 (TB 43-0108).

Repair procedures shall conform to requirements in AR 700-52.

### **DANGEROUS CHEMICALS**

Exposure to high concentrations of fire extinguishing agents can cause severe irritation of eyes and nose.

Corrosive Battery Electrolyte (potassium Hydroxide). Wear rubber gloves, apron, and face shield when handling leaking batteries. If potassium hydroxide is spilled on clothing, or other material, wash immediately with clean water. If spilled on personnel, immediately start flushing the affected area with clean water. Continue washing until medical assistance arrives.

Use solvents or chemicals in a well ventilated area. Do not inhale vapors or allow to come in contact with skin or eyes. Observe proper fire prevention rules.

### **NOISE LEVEL**

Sound pressure levels in the helicopter during some operating conditions exceed the Surgeon Generals hearing conservation criteria as defined in TB MED 251.

Hearing, protection devices, such as the aviator helmet or ear plugs, are required to be worn by all personnel in and around the helicopter during its operation.

### **ASBESTOS FIBERS**

Avoid creating dust. Breathing asbestos dust may cause serious bodily harm.

### **ARMAMENT**

When working on, or near an armed helicopter, take all possible precautions to avoid accidental firing of armament.

Personnel shall not occupy possible firing pattern in front of or up to 20 feet behind rocket pods.

Munitions shall be handled by authorized personnel only. All weapons shall be dry-fired. Only dummy ammunition with smooth cases like live ammunition shall be used.

### **JETTISON**

All ground safety pins must be removed before flight. Failure to do so will prevent emergency jettison of stores.

Jettison circuit may be activated with BAT switch OFF and pilot WING STORES JTSN circuit breaker OPEN. For positive deactivation of jettison circuit, open both the PLT JTSN circuit breaker and the GNR JTSN circuit breaker located in the pilot's side console. Serious injury can result from accidental ground jettison.

### **SANDING DUST**

Sanding on reinforced laminated glass produces fine dust that may cause skin irritations. Observed necessary protective measures.

### **TRANSMISSION LEVELING**

Do not attempt to level transmission with "Jacks Only". Hoist must be used in conjunction with jacks while lifting transmission.

### **EXTERNAL STORES**

Prior to any helicopter maintenance functions that require external stores be removed, JETTISON cartridge shall be removed.

Remove jettison cartridges from pylon stores ejection device prior to placing helicopter in a hangar, to prevent injury to personnel and damage to equipment.

Exception: Removal is not necessary when helicopter is to be placed in hangar for short-term, providing both PLT JTSN and GNR JETSJN circuit breakers in the pilot's side console are OPEN, and warning signs indicate that helicopter has an armed jettison system.

### **CANOPY REMOVAL SYSTEM**

Ground safety pins must be installed in pilot and gunner arming firing handles of canopy removal system whenever the helicopter is on the ground. Pins should be installed by crew.

### **CLEANING HYDRAULIC COMPONENTS**

The use of any alcohol in cleaning components which contact hydraulic fluids is prohibited. Formation of a polymeric residue can result, which could impair mechanical operation of the component.

### HANDLING HYDRAULIC FLUID (MIL-H-83282)

When handling hydraulic fluid (MIL-H-83282), Table 1-3, Item 61, observe the following:

- Prolonged contact with liquid or mist can irritate eyes and skin.
- After any prolonged contact with skin, immediately wash contacted area with soap and water. If liquid contacts eyes, flush them immediately with clear water.
- If liquid is swallowed, do not induce vomiting; get immediate medical attention.
- Wear rubber gloves when handling liquid. If prolonged contact with mist is likely, wear an appropriate respirator.
- When fluid is decomposed by heating, toxic gases are released.

### EPOXY BASED ADHESIVE

Epoxy based adhesive, P/N EA934, contains an asbestos filler which could be inhaled or ingested during grinding, cutting, or sanding operations on cured epoxy material.

### TOOLS

Use only chrome plated steel or unplated steel tools for disassembly or reassembly procedures described in this manual. Use of cadmium or zinc plated tools is not permitted.

### GROUNDING

All aircraft parked outside will be grounded and bonded, in accordance with FM 1-500, to the aerospace ground equipment while servicing, i.e., fueling or defueling, arming (ammunition or explosives), oxygen, hydraulic fluids or any flammable liquids. Grounding is not necessary for aircraft parked outside unless one of the above is being accomplished.

**INSPECTION OF REMOVED COMPONENTS**

When components are being removed from an aircraft, all inspections required by the next phase maintenance inspection must be accomplished prior to either immediate re-use or storage. Upon installation, the component will be inspected in accordance with the current phase (either that phase the receiving aircraft is in or if in between phase, the last phase performed). This will ensure that a re-used component will not overfly any PM inspections, and that it will be properly interfaced with the receiving aircraft phase sequence.





TECHNICAL MANUAL

NO. 55-1520-236-23

HEADQUARTERS  
DEPARTMENT OF THE ARMY  
WASHINGTON, D. C., 8 May 1980

AVIATION UNIT AND INTERMEDIATE MAINTENANCE MANUAL  
ARMY MODEL

AH-1P (PROD)  
AH-1E (ECAS)  
AH-1 F (MODERNIZED COBRA)  
HELICOPTERS

**REPORTING ERRORS AND RECOMMENDING IMPROVEMENTS**

You can help improve this manual. If you find any mistakes, or if you know of away to improve these procedures, please let us know. Mail your letter or DA Form 2028 (Recommended Changes to Publications end Blank Forms), or DA Form 2028-2 located in the back of this manual directly to: Commander, US Army Aviation and Troop Command, ATTN: AMSAT-I-MP, 4300 Goodfellow Blvd., St. Louis, MO 63120-1798. A reply will be furnished directly to you.

DISTRIBUTION STATEMENT A: Approved for public release; distribution is unlimited.

TABLE OF CONTENTS

		PARAGRAPH	PAGE
<b>VOLUME 1</b>			
<b>CHAPTER 1</b>	<b>AIRCRAFT GENERAL</b>		
Section I	Servicing . . . . .	1-1	1-1
Section II	Lubrication . . . . .	1-28	1-41
Section III	Handling, jacking, mooring, hoisting, and sling loading . . . . .	1-30	1-45
Section IV	Inspection requirements . . . . .	1-55	1-58
Section V	Overhaul and retirement schedule . . . . .	1-58	1-87
Section VI	Flight safety critical aircraft parts (FSCAP) program . . . . .	1-59	1-89
<b>CHAPTER 2</b>	<b>AIRFRAME</b>		
Section I	Structural . . . . .	2-1	2-1
Section II	Fuselage . . . . .	2-41	2-113
Section III	Tailboom . . . . .	2-281	2-229
Section IV	Wing . . . . .	2-335	2-245
Section V	Deleted	2-352	2-258
<b>CHAPTER 3</b>	<b>LANDING GEAR</b>		
Section 1	Landing Gear . . . . .	3-1	3-1
Section II	Skids/Struts (Not Applicable) . . . . .		3-29
Section III	Floats (Not Applicable) . . . . .		3-29
Section IV	Skis (Not Applicable) . . . . .		3-29
Section V	Brakes (Not Applicable) . . . . .		3-29
<b>CHAPTER 4</b>	<b>POWER PLANT</b>		
Section I	Power plant . . . . .	4-1	4-1
Section II	Cooling system (Not Applicable) . . . . .		4-17

		PARAGRAPH	PAGE
Section III	Air induction system . . . . .	4-24	4-18
Section IV	Exhaust system . . . . .	4-39	4-36
Section V	Oil system . . . . .	4-59	4-50.2
Section VI	Ignition system (Not Applicable) . . . . .		4-69
Section VII	Power lever controls . . . . .	4-98	4-69
Section VIII	Quick change assembly . . . . .	4-114	4-79
<b>CHAPTER 5</b>	<b>ROTORS</b>		
Section I	Main rotor system . . . . .	5-3	5-1
Section II	Main rotor hub and blades . . . . .	5-8	5-2.2
Section III	Main rotor controls . . . . .	5-47	5-103
Section IV	Tail rotor system . . . . .	5-72	5-138
Section V	Tail rotor hub and blade assembly. . . . .	5-79	5-141
Section VI	Tail rotor hub and controls . . . . .	5-89	5-148
Section VII	Tail rotor blades . . . . .	5-107	5-170
Section VIII	Tracking and balancing procedures . . . . .	5-114	5-181
<b>CHAPTER 6</b>	<b>DRIVE TRAIN SYSTEM</b>		
Section I	Drive train . . . . .	6-1	6-1
Section II	Main drive shaft . . . . .	6-5	6-7
Section III	Main transmission . . . . .	6-20	6-24
Section IV	Tail rotor drive shaft . . . . .	6-75	6-75
Section V	Intermediate gearbox . . . . .	6-96	6-86
Section VI	Tail rotor gearbox . . . . .	6-113	6-103
section VII	Transmission oil system . . . . .	6-129	6-120.1
<b>VOLUME II</b>			
<b>CHAPTER 7</b>	<b>HYDRAULIC AND PNEUMATIC SYSTEMS . . . . .</b>		7-1
<b>CHAPTER 8</b>	<b>INSTRUMENTS SYSTEM</b>		
Section I	Instrument maintenance . . . . .	8-1	8-1
Section II	Engine instruments . . . . .	8-10	8-7
Section III	Flight instruments . . . . .	8-114	8-25
Section IV	Navigation instruments . . . . .	8-185	8-36
Section V	Miillaneous instruments . . . . .	8-198	8-38
Section VI	Instrument panels . . . . .	8-285	8-52
<b>CHAPTER 9</b>	<b>ELECTRICALS SYSTEMS</b>		
Section I	Electrical systems maintenance. . . . .	9-1	9-1
Section II	Direct current power distribution system . . . . .	8-37	9-27
Section III	Alternating current power distibution system . . . . .	9-119	9-56
Section IV	Starting system . . . . .	9-238	9-73
Section V	Ignition system . . . . .	8-246	9-75
Section VI	Lighting provisions . . . . .	8-254	9-76
Section VII	Miscellaneous equipment . . . . .	9-340	9-102
Section VIII	<b>P</b> Armament systems arcuitry . . . . .	9-412	9-122

		PARAGRAPH	PAGE
Section IX	<b>E</b> Armament systems circuitry .....	9-442	9-154
Sction X	<b>M</b> Armament and fire control systems circuitry .....	9-496	9-185
<b>CHAPTER 10</b>	<b>FUELSYSTEMS</b>		
Section I	Fuel systems .....	10-1	101
Section II	Fuel cells .....	10-73	10-17
<b>CHAPTER 11</b>	<b>FLIGHT ONTROLS</b>		
Section I	Flight controls .....	11-1	11-1
Section II	Flight controls components .....	11-145	11-81
<b>CHAPTER 12</b>	<b>UTILITY SYSTEM</b>		
Section I	Fire detection system .....	12-1	12-1
Section II	Rain removal system .....	12-9	12-4
Section III	Defroster system .....	12-10	12-4
section IV	Low G Warning System .....	12-11	12-5
<b>CHAPTER 13</b>	<b>ENVIRONMENTAL CONTROL SYSTEM</b>		
Section I	Heating systems .....	13-1	13-1
Section II	Air cooling systems .....	13-125	13-37
<b>CHAPTER 14</b>	<b>HOIST AND WINCHES (Nonapplicable) .....</b>	14-1	14-1
<b>CHAPTER 15</b>	<b>AUXILIARY POWER PLANT (Not Applicable) .....</b>	15-1	15-1
<b>CHAPTER 16</b>	<b>MISSION EQUIPMENT .....</b>	16-1	16-1
<b>CHAPTER 17</b>	<b>EMERGENCY EQUIPMENT .....</b>	17-1	17-1
<b>APPENDIX A</b>	<b>REFERENCES .....</b>		A-1
<b>APPENDIX B</b>	<b>MAINTENANCE ALLOCATION CHART .....</b>		B-1
<b>APPENDIX C</b>	<b>AIRCRAFT INVENTORY MASTER GUIDE .....</b>		C-1
<b>VOLUME III</b>			
<b>APPENDIX D</b>	<b>ILLUSTRATED FIELD MANUFACTURE LIST .....</b>		D-1
<b>APPENDIX E</b>	<b>STORAGE OF AIR CRAFT</b>		
Section I	General information .....	E-1	E-1
Section II	Flyable storage .....	E-6	E-2
Section III	Short term storage .....	E-10	E 4
Section IV	Intermediate storage .....	E-14	E-11
<b>APPENDIX F</b>	<b>WIRING DIAGRAMS .....</b>		F-1
<b>APPENDIX G</b>	<b>WIRE LISTS .....</b>		G-1
<b>INDEX .....</b>			Index-1
<b>VOLUME IV</b>			
<b>FOLDOUTS .....</b>			FO-1
<b>VOLUME V</b>			
<b>FOLDOUTS .....</b>			FO-143

LIST OF ILLUSTRATIONS

NUMBER	TITLE	PAGE
1-1	Servicing Points Diagram .....	1-2
1-1.1	Receiver and Cap Assembly .....	1-2.3
1-2	Deleted	
1-3	Deleted	
1-4	Deleted	
1-5	Lubrication Chart .....	1-42
1-6	Ground Handling Diagram .....	1-46
1-7	Work Aid for Towing Ground Handling Gear .....	1-48
1-8	Jacking and Mooring Fittings .....	1-50
1-9	Covers Diagram .....	1-53
1-9.1	AH-1 Paved Surface Mooring Configuration .....	1-54.2
1-10	Mooring Diagram .....	1-55
1-11	Maintenance Hoist, T101520 .....	1-57
1-12	Inspection Area Diagram (Typical) .....	1-59
2-1	Fuselage Components and Tailboom .....	2-2.1
2-2	Structural Panels .....	2-4
2-3	Non-Structural Access Panels, Doors, and Fairings .....	2-8
2-4	Principal Dimensions - Airframe .....	2-14
2-5	Reference Lines - Airframe .....	2-16
2-6	Cleaning Chart .....	2-23
2-7	Type A - Damage, Body Panel Repairs .....	2-36
2-8	Type B - Damage, Body Panel Repairs .....	2-37
2-9	Type C - Damage, Body Panel Repairs .....	2-38
2-10	Type D - Damage, Body Panel Repairs .....	2-40
2-11	Primary Structural Caps - Left Side .....	2-42
2-12	Primary Structural Caps - Right Side .....	2-43
2-13	Pilot and Gunner Floor Panels .....	2-44
2-14	Bulkhead at Station 93.0 .....	2-45
2-15	Bulkhead at Station 148.5 and 171.61 .....	2-46
2-15.1	Ammo Floor Scuff Doubler Installation .....	2-46.1
2-16	Bulkhead at Stations 186.25 and 213.94 .....	2-47
2-17	Bulkhead at Stations 250.0 and 268.5 .....	2-48
2-18	R&L Main Beam Panels at Station 148.5 to 186.25 .....	2-49
2-19	R&L Main Beam Panels at Station 213.94 to 250.0 .....	2-50
2-20	Panel at Forward Fuel Cell at R.S. and Gunner Floor .....	2-51
2-21	R&L Beam Panels at Station 250 to B.S. 41.32 .....	2-52
2-22	Ammo Floor, Support Panel and Forward Fuel Cell Panel at Station 213.9 .....	2-53
2-23	Forward Fuel Cell Floor - Lower Panel Station 86 to 213 .....	2-54
2-24	Lower Aft Fuel Cell Panel at Station 250 to B.S. 41.32 .....	2-55
2-25	Engine Deck Installation at Station 213.94 to 298.75 .....	2-56
2-26	Forward Fuel Cell Panels - Main Beam at Station 186 to 214 .....	2-57
2-27	Edge Repair for Honeycomb Panels with Glass Skin Opposite Titanium .....	2-58
2-28	Edge Repair for Honeycomb Panels with Aluminum Alloy with Glass Edging .....	2-60
2-29	Edge Repair for Honeycomb Panels with Glass Finish at Channel .....	2-61
2-30	Typical Rivet Pattern for Channel Section Repair .....	2-62
2-31	Potted - Injection - Grommet Type Fasteners .....	2-64
2-31.1	HMPP Cowling Nut Plate Replacement .....	2-66.1
2-31.2	Stringer Repair .....	2-66.2
2-32	Longeron Damage Limits .....	2-82
2-33	Typical Tailboom Bulkhead Damage Limits .....	2-85
2-34	Tail Rotor Driveshaft Covers .....	2-87
2-35	Driveshaft Cover Hinges and Angles Damage .....	2-88
2-36	Damage Limits - Tailboom Attach Fitting .....	2-89
2-37	Damage Limits - Bearing Hanger Support Fitting .....	2-90

## LIST OF ILLUSTRATIONS (CONT)

NUMBER	TITLE	PAGE
2-38	Damage Limits - Intermediate Gearbox Support Installation .....	2-91
2-39	Damage Limits - Tail Rotor Drive Support Fitting .....	2-92
2-40	Vertical Fin Honeycomb Panels Damage .....	2-96
2-41	Edge Repair on Vertical Fin .....	2-100
2-42	Tailboom Longerons .....	2-101
2-43	Longeron Repair .....	2-102
2-43.1	Longeron Material Chart .....	2-104
2-44	Damage Skin, Frame, and Bulkhead Repair .....	2-104.1
2-45	Repair - Damaged Ribs - Bulkhead .....	2-105
2-46	Repair - Bulkhead Flanged Member .....	2-106
2-46.1	Tailboom Structural Material .....	2-106.1
2-47	Repair - Bulkhead "T" Cap - Extensive Damage .....	2-107
2-48	Injection Tape Fastener (Insert) in Vertical Fin Panel .....	2-111
2-48.1	Vertical Fin Ballast Weight Panel .....	2-112.2
2-49	Sheet Metal Panels and Skin .....	2-115
2-50	<b>P E</b> Fairing - Cowling for Pylon, Transmission, Engine, and Tailpipe .....	2-123
2-51	<b>M</b> Fairing and Cowling - Pylon, Transmission, Engine and IR Suppressor .....	2-126
2-52	IR Suppressor Cowling Installation .....	2-132
2-53	Firewalls and Driveshaft Fireshield Installation .....	2-139
2-54	Forward Engine Firewall Assembly (Prior to Incorporation of MWO 55-1520-236-50-12) .....	2-142
2-54.1	<b>E M</b> Forward Engine Firewall Assembly (After Incorporation of MWO 55-1520-236-50-12) .....	2-144.3
2-55	Aft Engine Firewall and Cowl Support .....	2-146
2-56	Tail Rotor Driveshaft Fireshield Assembly .....	2-152
2-57	Engine Air Induction Baffle Installation (Prior to Incorporation of MWO 55-1520-236-50-12) .....	2-154
2-57.1	<b>E M</b> Centrisep Particle Separator Engine Air Induction Baffle Installation (After Incorporation of MWO 55-1520-236-50-12) .....	2-154.1
2-58	Engine Air Induction Baffle Assembly (Prior to Incorporation of MWO 55-1520-236-50-12) .....	2-155
2-58.1	<b>E M</b> Centrisep Particle Separator Engine Air Induction Baffle Assembly (After Incorporation of MWO 55-1520-236-50-12) .....	2-158.1
2-59	Pilot Door - Installation .....	2-161
2-60	Gunner Door - Installation .....	2-164
2-61	Pilot Door - Assembly .....	2-167
2-62	Gunner Door - Assembly .....	2-169
2-63	Gunner Door Latch Assembly .....	2-170
2-64	Canopy Window and Windshield - Installation .....	2-176
2-65	Canopy Frame - Installation .....	2-178
2-66	Pilot Seat - Installation .....	2-179
2-67	Gunner Seat - Installation .....	2-180
2-68	Pilot Seat - Assembly .....	2-183
2-69	Engine Armor - Installation .....	2-188
2-70	Soundproofing Blanket - Installation .....	2-190.1
2-70.1	Wire Strike Protection System .....	2-190.2
2-70.2	Damage Limits - Wire Strike Deflector .....	2-191
2-71	Engine Mount Installation .....	2-192
2-72	Damage Limits - Aft Engine Mount Assembly (Tripod) .....	2-196
2-73	Damage Limits - Fittings for Aft Engine Mount (Tripod) .....	2-199
2-74	Aft Engine Mount (Tripod) Assembly .....	2-200
2-75	Damage Limits - Engine Mount Pillow Blocks (Left and Right) .....	2-202
2-76	Diagonal Brace Tube - Installation .....	2-204
2-77	Pylon Support - Installation .....	2-206
2-77.1	Pylon Mount Bolt Inspection Criteria .....	2-206.1

**LIST OF ILLUSTRATIONS (CON'T)**

NUMBER	TITLE	PAGE
2-78	Access Hole for Damper to Damper Support Fitting Mount Bolts .....	2-209
2-79	Fifth Mount and Fifth Mount Support Fitting - Installation .....	2-210
2-76.1	Bushing and Bearing Tool Kit LT-40 .....	2-212.2
2-79.2	Fifth Mount Assembly .....	2-212.3
2-79.3	Fifth Mount Bushing and Bearing Removal .....	2-212.3
2-79.4	Fifth Mount Bushing and Bearing Installation .....	2-212.4
2-79.5	Fifth Mount Bush Staking .....	2-212.4
2-80	Damper - Internal Yielding Inspection .....	2-214
2-81	Transmission Damper - Assembly .....	2-215
2-82	Damper Seal - Installation Tool .....	2-216
2-83	Damper Barrel Shim - Replacement .....	2-217
2-84	Damper Upper Shim - Replacement .....	2-218
2-85	Damper Lower Shim - Replacement .....	2-219
2-86	Hydraulic Fitting Supports - Installation .....	2-221
2-87	Damper Support Fitting - Elongated Holes .....	2-223
2-88	Damage Limits - Fifth Mount Support Fitting .....	2-224
2-89	Tow, Jack, and Mooring Fitting .....	2-226
2-90	Aft Section Assembly .....	2-230
2-91	Tail Boom Support Stand - Workaid .....	2-231
2-92	Tailboom Installation .....	2-232
2-92.1	Tailboom Installation .....	2-232.1
2-93	Tailboom and Elevator Skins .....	2-234
2-94	Tailboom and Synchronized Elevator - Structure .....	2-237
2-95	Tailskid - Installation .....	2-240
2-96	Aft Ballast - Installation .....	2-242
2-97	Synchronized Elevators - Installation .....	2-244
2-98	Wing Assembly - Installation .....	2-246
2-99	Wing Bushings - Limits Chart .....	2-250
2-100	Wing Skin Repair (External Hole) .....	2-251
2-101	Wing Skin Repair (External Crack) .....	2-252
2-102	Wing Skin Repair (Close to Frame, Spar, or Ribs) .....	2-253
2-103	Wing Skins, Fairings, Covers, Doors .....	2-254
2-104	Wing Fairing Repair (Leading - Trailing Edge) .....	2-256
2-105	Deleted	
3-1	Landing Gear and Support Installation .....	3-2
3-1.1	Crosstube Shim Fabrication .....	3-4.1
3-2	Crosstube - Deflection Inspection .....	3-5
3-3	Damage Limits - Crosstubes .....	3-6
	Skid Tube - Repairs .....	3-9
3-4.1	Skid Shoes - Standard, Heavy Duty .....	3-10.2
3-5	Crosstube Fairing Assembly .....	3-12
3-6	Landing Gear Support Spacer Installation .....	3-15

LIST OF ILLUSTRATIONS (CON'T)

NUMBER	TITLE	PAGE
3-7	Ground Handling Gear -assembly .....	3-17
3-8	Ground Handling Gear Pump, P/N BU0953B-Assembly .....	3-19
3-9	Ground Handling Gear Pump, P/N HP9902-41-10 .....	3-21
3-10	Work Aid - Packing Nut Tool Removal/Installation - Fabrication Instructions .....	3-23
3-11	Ground Handling Wheels -Adjustment Dimensions .....	3-25
4-1	Power Plant Installation - Right Side... ..	4-2
4-2	Power Plant installation -Left Side .....	4-2.2
4-3	Engine Vibration Test Equipment Cabling Tiedown .....	4-4
4-3.1	Deleted	
4-4	Engine installation .....	4-7
4-5	Engine Mount Fittings(Trunnions) installation .....	4-13
4-6	Damage Limits Aft - Engine Mount Fittings (Trunnions) and Bearings .....	4-16
4-7	Particle Separator and FOD Screen Installation (Prior to Incorporation of MWO 55-1520-236-50-12) .....	4-19
4-7.1	<b>E M</b> Centrisep Particle Separator Installation (After Incorporation of MWO 55-1520-236-50-12) .....	4-22.2
4-8	Particle Separator-Air Flow Diagram (Prior to Incorporation of MWO 55-1520-236-50-12) .....	4-23
4-8.1	<b>E M</b> Centrisep Particle Separator Air Flow Diagram (After Incorporation of MWO 55-1520-236-50-12) .....	4-24.1
4-9	Particle Separator and FOD Screen Assemblies (Prior to incorporation of MWO 55-1520-236-50-12) .....	4-26
4-10	Inlet Vane Reinforcement Doubler-Fabrication .....	4-30
4-10.1	<b>E M</b> Centrisep Particle Separator Repair/Replacement (After Incorporation of MWO 55-1520-236-50-12) .....	4-30.1
4-11	FOD (Foreign Object Damage)Screen Installation .....	4-34
4-12	<b>P E</b> Exhaust System Components .....	4-37
4-13	<b>P E</b> Engine Tailpipe Repair .....	4-38
4-14	Engine Deck and Firewall Sealing .....	4-40
4-15	<b>P E</b> Exhaust System Components with IR Suppression Installation .....	4-41
4-15.1	Hot Metal Plus Plume Suppressor .....	4-44.10
4-15.2	Outer Body Half -Section .....	4-44.11
4-16	Repair Procedures -infrared Suppression System .....	4-45
4-17	<b>M</b> Exhaust System Components with IR Suppression -Installation .....	4-47
4-17.1	<b>M</b> Suppressor Major Structural Elements .....	4-50
4-18	Engine Oil System installation .....	4-50.1
4-18.1	ODDS Oil Separator and Oil Filter installation (MWO 1-1520-236-50-30) .....	4-50.3
4-19	Engine Oil System Schematic .....	4-54.3
4-19.1	Oil Separator (Lubriclone) Assembly .....	4-54.4
4-19.2	Deleted	
4-19.3	Engine External Oil Fitter .....	4-54.7
4-20	Oil Tank Installation .....	4-57

**LIST OF ILLUSTRATIONS (CON'T)**

NUMBER	TITLE	PAGE
4-21	Engine Oil Cooler Installation .....	4-60
4-22	Oil Cooler Cleaning Schematic .....	4-61
4-23	Engine Oil Cooler Turbine Fan .....	4-64
4-24	Oil Cooler Turbine Fan Assembly .....	4-66
4-25	Power Lever Control System Installation .....	4-70
4-26	Engine Idle Stop Installation .....	4-73
4-27	Droop Compensator Controls Installation .....	4-75
4-28	Rigging Procedures – Droop Compensator Controls .....	4-79
4-29	Engine Shipping Container .....	4-81
4-30	Ignition Unit .....	4-83
4-31	Aft Engine Trunnion Installation .....	4-84
4-32	Trunnion, Cambox, and Linear Actuator Installation .....	4-85
4-33	Power Turbine Tachometer Generator, Oil Pressure Transducer, Oil Pressure Switch, and Fuel Pressure Switch Installation .....	4-86



LIST OF ILLUSTRATIONS (CON'T)

NUMBER	TITLE	PAGE
4-34	Starter Generator and Gas Producer Tachometer Generator . . . . .	487
4-35	Installation Engine Torque Transducer Hose . . . . .	4-89
4-36	Installation Fuel Drain and Bleed Lines . . . . .	4-91
4-37	Installation Starter Fuel Filter and Oil Bypass Valve Hose . . . . .	4-92
4-38	Installation Bleed Air Tubing . . . . .	4-93
4-39	Installation Oil Hose . . . . .	4-95
<b>4-40</b>	Installation Heat Shield Tailpipe and Ejector . . . . .	4-40 4-96
4-41	Electrical Cable Installation Engine Left Side . . . . .	4-97
4-42	Electrical Cable Installation Engine Right Side . . . . .	4-100
5-1	Main Rotor System . . . . .	5-2
5-2	Main Rotor Installation . . . . .	5-4
5-3	Main Rotor System Torque Values . . . . .	5-6
5-4	Tool Application Grip Lock Installation on Pitch Horn . . . . .	5-7
54.1	Barrel Jack Installation . . . . .	5-8
5-4.2	Barrel Jack Work Aid . . . . .	5-8.1
5-5	Tool Application Main Rotor Mast Nut Removal - Installation . . . . .	5-8.2
5-6	Tool Application Alignment of Main Rotor Hub and Blade . . . . .	5-9
5-7	Damage Limits Cone Set . . . . .	5-11
5-8	Pitch Link Assembly Adjustments . . . . .	5-13
5-9	Pitch Link Assembly . . . . .	5-14
5-10	Main Rotor Hub and Blade Assembly . . . . .	5-16
5-11	Work Aid for Main Rotor Blade Bolt Removal Fabrication Instructions (AVIM) . . . . .	5-17
5-12	Work Aid Application Main Rotor Blade Retaining Bolt Removal . . . . .	5-18
5-13	B540 Main Rotor Blade . . . . .	5-23
5-14	B540 Main Rotor Blade Authorized patch Area (AVIM) . . . . .	5-26
6-15	B540 Main Rotor Blade Trim Tab Installation . . . . .	5-27
5-16	K747 Main Rotor Blade (Part Numbers K747-003-205, -209, -303) . . . . .	5-30.1
5-16.1	K747 Main Rotor Blade (Part Numbers K747-003-309, -401, -403) . . . . .	5-31
5-17	External Appearance Changes to K747-003-205/-309, -209/-401, and -303/-403 Blades Resulting from Improved Weight Retention Features . . . . .	5-32
5-18	Internal Modification Incorporated in K747-003-205/-309, -209/-401, and -303/-403 Blades for Improved Weight Retention . . . . .	5-33
5-19	Damage Limits - Root Fitting (K747 Blade) . . . . .	5-36.2
5-19.1	Damage Limits - Root Fittings - Part Number K747-083-1 (K747 Blade) . . . . .	5-37
5-20	Damage Limits - Drag Strut (P/N K747-072-1) (K747 Blade) . . . . .	5-38
5-20.1	Damage Limits - Drag Strut - Part Number K747-082-1 (K747 Blade) . . . . .	5-38.1
5-21	Inspection of K747-003-205/-309, -209/401, -303/403 Blades for Loss of Blade Weight Retention Integrity . . . . .	5-39
5-22	Proximity Limits for Patches - K747 Main Rotor Blades . . . . .	5-40
5-23	Balance Adjustment for Patches (K747 Blade) . . . . .	5-43
5-24	Root Fitting Assembly (K747-205, -209,-303 Blades) . . . . .	5-52
5-24.1	Root Fitting Assembly (-309, -401,403 Blades) . . . . .	5-52.1
5-24.2	Drag Strut Assembly (-309, -401,-403 Blades) . . . . .	5-52.3
5-25	Application of Skin Patch (K747 Blade) . . . . .	5-54
5-26	Curing Patch with Blade Repair Fixture (K747 Blade) . . . . .	5-56
5-27	Installation of Plug Patch (K747 Blade) . . . . .	5-60

LIST OF ILLUSTRATIONS (CON'T)

NUMBER	TITLE	PAGE
5-28	Typical Double Plug Patch Repair (K747 Blade) . . . . .	5-67
5-28.1	Application of Trailing Edge Doubler Patch (K747 Blade) . . . . .	5-68
5-28.2	Spline Repair (K747 Blade) . . . . .	5-71
5-28.3	Rebonding Delaminated Leading Edge Erosion Guard (K747 Blade) . . . . .	5-72.1
5-28.4	Typical Repair of Fluorocarbon Erosion Guard Nicks and Cuts Using Kit, P/N 747-207 . . . . .	5-72.3
5-28.5	Application of Leading Edge Erosion Guard Patch (K747 Blade) . . . . .	5-72.5
5-28.6	Placement of Erosion Guard Replacement Part (Kit, P/N K747-206- 1 ) Method for Determining Current Boot Material and Thickness (K747 Blade Series) . . . . .	5-72.7
5-28.7	K747 Blade Uralite Repair . . . . .	5-72.10
5-28.8	Application of Vacuum Bagging Materials and Placement of Erosion Guard . . . . .	5-72.11
5-28.9	Repair Parts and Specimen Orientation (Kit, P/N K747-206) . . . . .	5-72.15
5-28.10	Vacuum Bagging for Installation of Erosion Guard Repair Kit, P/N K747-206 . . . . .	5-72.18
5-28.11	Improvised Mold for Casting a Small Section of Leading Edge Filler . . . . .	5-72.21
5-28.12	Repair Parts Orientation Use for Removal and Installation of Stainless Steel Erosion Guard - K747-003-303M03 and -303/-403 Field Modified Blades . . . . .	5-72.23
5-28.13	Preparation of K747-003-303/-403 Blade for Application of Sealant . . . . .	5-72.24
5-28.14	Application of Sealant to Stainless Steel Guard for K747-003-303/-403 Blade . . . . .	5-72.26
5-28.15	Stainless Steel Erosion Guard Holding Fixture . . . . .	5-72.27
5-28.16	Masking for Paint Touch-Up After Installation of Kit K747-206 . . . . .	5-72.31
5-29	Main Rotor Hub Yoke Extension and Grip Assembly . . . . .	5-72.35
5-30	Main Rotor Hub Yoke and Trunnion . . . . .	5-74
5-31	Main Rotor Bearing Wear Patterns . . . . .	5-77
5-32	Damage Limits - Main Rotor Hub Yoke Extension . . . . .	5-78
5-33	Damage Limits - Main Rotor Hub Bolt Holes . . . . .	5-79
5-34	Damage Limits - Main Rotor Hub Yoke . . . . .	5-81
5-35	Damage Limits - Main Rotor Hub Grip . . . . .	5-82
5-36	Damage Limits - Main Rotor Hub Strap Fitting . . . . .	5-83
5-37	Damage Limits - Pitch Horn Bushing . . . . .	5-85
5-38	Damage Limits - Main Rotor Hub Pitch Horn 209-010- 109-5 (Prior to Accomplishment of MWO 55-1520-244-50-6) . . . . .	5-86
5-38.1	Damage Limits - Main Rotor Hub Pitch Horn 209-010-109-109 (After Accomplishment of MWO 55-1520-244-50-6 and MWO 55-1520-244-50-9) . . . . .	5-86.1
5-39	Damage Limits - Main Rotor Drag Brace . . . . .	5-87
5-40	Damage Limits - Main Rotor Hub Trunnion . . . . .	5-88
5-40.1	Damage Limits - Hub Moment Spring Plate . . . . .	5-88.1
5-40.2	Damage Limits - Hub Moment Spring Strap . . . . .	5-88.2
5-41	Damage Limits - Main Rotor Hub Elastomeric Bearing . . . . .	5-89
5-42	Main Rotor Hub Yoke Chafing Pad Installation Dimensions . . . . .	5-90
5-42.1	Main Rotor Hub Yoke Buffer Installation - Dimensions . . . . .	5-90
5-43	Tool Application - Bearing Removal From Housing . . . . .	5-90.2
5-44	Tool Application - Bearing Removal From Grip . . . . .	5-92
5-45	Tool Application - Bearing and Seal Installation in Grip . . . . .	5-93
5-46	Tool Application - Main Rotor Hub Trunnion Centering . . . . .	5-96
5-47	Tool Application - Grip Spacing Adjustment . . . . .	5-97
5-48	Main Rotor Hub Grip Dust Seal to Radius Ring Dimension . . . . .	5-99
5-49	Rotor Balancing Kit P/N 7A050 . . . . .	5-101
5-50	Tool Application - Main Rotor Hub Balancing . . . . .	5-102
5-51	Main Rotor Controls Installation . . . . .	5-104
5-52	Tool Application - Spline Plate Wear Measurement . . . . .	5-107
5-52.1	Hub Moment Spring Suppon Assembly - Installation (MWO 55-1520-244-50-3 Incorporated)	5-108

LIST OF ILLUSTRATIONS (CONT)

NUMBER	TITLE	PAGE
5-53	Collective Lever Trust Washer Wear Limits .....	5-108.1
5-53.1	Rod End Clevis Movement .....	5-108.4
5-53.2	Rod End Bearing .....	5-108.5
5-54	Damage Limits – Pitch Link Assembly (Prior to Accomplishment of MWO 55-1520-244-50-9) .....	5-109
5-54.1	Damage Limits – Pitch Link Assembly 209-010-520-103 (After Accomplishment of MWO 55-1520-244-50-9) .....	5-110.1
5-55	Damage Limits – Spline Plate .....	5-110.2
5-56	Damage Limits – Collective Lever .....	5-111
5-57	Damage Limits – Collective Lever Idle Link .....	5-112
5-58	Collective Lever Idle Link Assembly .....	5-113
5-59	Damage Limits – Swashplate Anti-Drive Link .....	5-114
5-60	Swashplate Anti-Drive Link .....	5-115
5-61	Damage Limits – Swashplate Anti-Drive Assembly Bellcrank .....	5-116
5-62	Damage Limits – Swashplate Anti-Drive Assembly Support .....	5-117
5-63	Swashplate Anti-Drive Assembly .....	5-118
5-63.1	Damage Limits – Hub Moment Spring Support Set, P/N 209-011-212-101 (MWO 55-1520-244-50-3 Incorporated) .....	5-120.2
5-63.2	Damage Limits – Hub Moment Spring .....	5-120.3
5-64	Scissors and Sleeve Assembly .....	5-121
5-65	Damage Limits – Hub, Sleeve, Scissors and Link .....	5-124
5-65.1	Installation of Shims .....	5-130.1
5-65.2	Collet Work Aid .....	5-130.1
5-66	Swashplate and Support Assembly .....	5-132
5-67	Damage Limits – Swashplate and Support Assembly .....	5-135
5-68	Tail Rotor Installation .....	5-139
5-69	Tail Rotor Hub and Blade Assembly .....	5-144
5-70	Tool Application – Tail Rotor Hub and Blade Assembly Balancing .....	5-146
5-71	Tail Rotor Hub Assembly .....	5-150
5-72	Damage Limits – Tail Rotor Hub Yoke .....	5-151
5-73	Damage Limits – Tail Rotor Hub Trunnion Set .....	5-152
5-74	Bearing Staking Tool P/N T101577 .....	5-153
5-75	Tool Application – Bearing Installation (Staking) in Tail Rotor Yoke .....	5-155
5-76	Tail Rotor Controls – Crosshead, Weights, Links and Control Tube .....	5-156
5-77	Damage Limits – Tail Rotor Control Crosshead .....	5-160
5-78	Damage Limits – Tail Rotor Control Counterweight Bellcrank .....	5-161
5-79	Damage Limits – Tail Rotor Controls Pitch Link .....	5-162
5-80	Damage Limits – Tail Rotor Control Counterweight Link .....	5-163
5-81	Damage Limits – Tail Rotor Control Counterweight Support .....	5-164
5-82	Damage Limits – Tail Rotor Control Tube .....	5-165
5-83	Damage Limits – Link Assembly .....	5-166
5-84	Damage Limits – Idler .....	5-167
5-85	Damage Limits – Lever .....	5-168



## LIST OF ILLUSTRATIONS (CONT)

NUMBER	TITLE	PAGE
5-86	Damage Limits – Tail Rotor Retention Nut .....	5-169
5-87	Tail Rotor Blade Pitch Horn Installation .....	5-171
5-88	Tail Rotor Blade Assembly .....	5-172
5-89	Tail Rotor Blade Station Diagram and Scratch –Type Damage Area Locations .....	5-173
5-90	Tail Rotor Blade – Area Authorized for Patch – Type Repair .....	5-174
5-91	Tail Rotor Blade Butt Area Repair .....	5-176
5-92	Damage Limits – Tail Rotor Blade Pitch Horn .....	5-178
5-93	Main Rotor Tracking Chart .....	5-182
5-94	Vertical Vibration Correction Chart .....	5-183
5-95	Vertical and Lateral Vibration Chart for K747 Rotor Blades .....	5-185
5-96	Lateral Vibration Correction Chart for B-540 Rotor Blades .....	5-187
5-97	Tracking Main Rotor .....	5-188
5-98	Tracking Main Rotor .....	5-189
5-99	Vibrex 4591 System Components and Carrying Case .....	5-191
5-100	A Main Rotor Balance Chart .....	5-194
5-101	Reading a Main Rotor Balance Chart .....	5-195
5-102	Reading a Main Rotor Balance Chart with an Incorrect “Clock Angle” .....	5-196
5-103	Reading the Tail – Rotor Charts .....	5-198
5-104	Magnetic Pickup and Double Interrupter Installation .....	5-200
5-105	Magnetic Pickup/Interrupter Installation .....	5-201
5-106	Magnetic Pickup Cable Installation .....	5-202
5-107	Balancer Installation .....	5-203
5-108	Lateral Accelerometer Installation .....	5-204

**LIST OF ILLUSTRATIONS (CON'T)**

NUMBER	TITLE	PAGE
5-109	Vertical Accelerometer Installation .....	5-205
5-110	Deleted	
5-111	Tip Targets Installation .....	5-208
5-112	Reflective Target Installation .....	5-209
5-113	Reading the Main Rotor Chart .....	5-210
5-114	Reading the Main Rotor Tracking Chart .....	5-212
5-115	Accelerometer Cable Installation (Typical) .....	5-214
5-116	Tracking Tail Rotor .....	5-215
5-117	Balancing Tail Rotor .....	5-217
6-1	Drive Train (Typical) .....	6-4
6-2	Gearbox Oil Contamination – Description and Corrective Action .....	6-5
6-2.1	Typical Oil System Debris at 6X Magnification .....	6-6.3
6-2.2	Deleted	
6-3	Main Driveshaft Installation .....	6-8
6-4	Tool Application – Transmission Positioning Jacks P/N T101440 (T35) .....	6-10
6-5	Tool Application – Engine to Transmission Driveshaft Alignment P/N T101419 (T35) .....	6-11
6-6	Main Driveshaft Assembly .....	6-13
6-7	Inspection and Lubrication of Main Driveshaft .....	6-14.1
6-7.1	Main Driveshaft Internal Corrosion Area .....	6-17
6-8	Coupling Wear Criteria for Driveshaft .....	6-18
6-9	Damage Limits – Main Driveshaft Assembly .....	6-20
6-9.1	Main Driveshaft .....	6-20.1
6-9.2	Main Driveshaft Installation and Removal Tool .....	6-20.2
6-9.3	Work Aid Tool Installed on Main Driveshaft .....	6-20.2
6-9.4	Main Driveshaft Damage Limits .....	6-20.3
6-10	Transmission Quills .....	6-25
6-11	Transmission Installation .....	6-27
6-12	Transmission Buildup .....	6-29
6-13	<b>P</b> Transducer Bracket Installation .....	6-32
6-14	Damage Limits – Transmission .....	6-34
6-15	Transmission Shipping Covers, Caps, and Plugs .....	6-41
8-15.1	Lift Link Attaching Point .....	6-44.1
6-16	Main Input Quill Assembly .....	6-45.1
6-16.1	Transmission Input Quill Work Aid (Sheet 1 of 2) .....	6-46.1
6-16.2	Transmission Input Quill Work Aid (Sheet 2 of 2) .....	6-46.2
6-16.3	Input Drive Quill Wear Sleeve Replacement .....	6-46.3
6-17	Work Aid – Main Input Drive Quill Installation .....	6-47
6-18	Damage Limits – Tail Rotor Drive Quill .....	6-50
6-19	Tail Rotor Drive Quill Assembly .....	6-53
6-20	Hydraulic Pump and Tachometer Drive Quill Assembly .....	6-56
6-21	Fan Drive Quill Assembly .....	6-58
6-22	Work Aid – Quill Installation .....	6-59
6-23	<b>E M</b> Alternator Drive Quill Assembly .....	6-62
6-24	Main Rotor Mast Assembly .....	6-64
6-24.1	Inspection of Buffers and Plates .....	6-65
6-24.2	Workaid for Mast Buffer .....	6-66
6-25	Damage Limits – Main Rotor Mast Assembly .....	6-66.1
6-26	Deformation Limits – Main Rotor Mast .....	6-68
6-27	Damage Limits – Main Rotor Mast Bearing and Mast Bearing Retaining Plate .....	6-69
6-28	Transmission Top Case Dimension Check .....	6-73
6-29	Tail Rotor Driveshaft Installation .....	6-76
6-30	Tail Rotor Driveshaft Inspection Diagram .....	6-77
6-31	Tail Rotor Driveshaft Hanger Assembly .....	6-81

## LIST OF ILLUSTRATIONS (CONT)

NUMBER	TITLE	PAGE
6-32	Coupling Teeth Wear Patterns .....	6-82
6-33	Work Aid – Driveshaft Hanger Support Alignment .....	6-85
6-34	Intermediate Gearbox Installation .....	6-87
6-35	Intermediate Gearbox Quill, Seals, and Couplings (Typical) .....	6-88
6-35.1	Intermediate and Tail Rotor Gearbox Troubleshooting Chart .....	6-90.2
6-36	Damage Limits – Intermediate Gearbox .....	6-91
6-37	Oil Filler Cap Assembly .....	6-99
6-38	Tail Rotor Drive Gearbox Installation .....	6-103
6-39	Tail Rotor Drive Gearbox Assembly .....	6-105
6-40	Tail Rotor Drive Gearbox Input Quill .....	6-106
6-41	Damage Limits – Tail Rotor Drive Gearbox .....	6-108
6-42	Roller Bearing Wear Patterns .....	6-115
6-43	Tail Rotor Drive Gearbox Gear Patterns .....	6-116
6-44	Tool Application – Removal/Installation of Tail Rotor Drive Gearbox Input Quill Retainer Bolt .....	6-119
6-45	Tool Application – Removal/Installation of Tail Rotor Drive Gearbox Input Quill Retainer Nut .....	6-120
6-45.1	Driveshaft/Spherical Couplings .....	6-120.2
6-45.2	Coupling Inspection .....	6-120.2
6-46	Transmission Oil System Schematic (Typical) .....	6-126
6-47	Transmission Oil System Installation .....	6-127
6-48	Transmission Oil Pump .....	6-129
6-49	Transmission Oil Pump – Test Setup .....	6-131
6-50	Transmission Oil Cooler Installation .....	6-132
6-50.1	Oil Cooler Cleaning Schematic .....	6-132.2
6-51	Oil Cooler Automatic Emergency Bypass Valve Assembly .....	6-135
6-52	Damage Limits – Inlet Fitting .....	6-137
6-53	Damage Limits – Return Bypass Fitting .....	6-138
6-54	Damage Limits – Inlet Bypass Piston .....	6-139
6-55	Damage Limits – Piston .....	6-140





## LIST OF ILLUSTRATIONS (CONT)

NUMBER	TITLE	PAGE
6-56	Damage Limits - Nozzles .....	6-141
6-57	Damage Limits - Sleeve .....	6-142
6-58	Damage Limits - Universal Fitting Bolt and Elbow .....	6-143
6-59	Damage Limits - Housing Assembly .....	6-144
6-60	Damage Limits - Plunger .....	6-146
6-61	Damage Limits - Elbow Fitting .....	6-147
6-62	Fittings - Repair .....	6-148
6-63	Nozzles - Repair .....	6-149
6-64	Plunger - Repair .....	6-149
6-65	Work Aid Application - Plunger and Piston .....	6-150
6-66	Oil Cooler Automatic Emergency Bypass Valve - Bench Test Schematic .....	6-151
6-67	Transmission External Oil Filter Installation (Typical) .....	6-153
6-67.1	Transmission External Oil Filter Installation (After Incorporation of MWO 1-1520-236-50-30) .....	6-154.3
6-67.2	Transmission External Oil Filter (After Incorporation of MWO 1-1520-236-50-30) .....	6-154.4
6-68	Transmission Oil Filter (Primary) Assembly .....	6-155
6-69	Transmission Oil Manifold Installation .....	6-158
6-70	Transmission Oil Pressure Relief Valve Assembly .....	6-159
7-1	<b>P</b> Hydraulic System .....	7-3
7-2	<b>P</b> Emergency (Electric Motor Driven) Hydraulic System .....	7-8
7-3	Dual Hydraulic Servo Cylinders Installation .....	7-9
7-4	Hydraulic Reservoirs .....	7-28
7-5	<b>P</b> Hydraulic Reservoir - Emergency System .....	7-29
7-6	Hydraulic Reservoir Assembly .....	7-31
7-7	Emergency Electric Motor Driven Hydraulic Pump Installation .....	7-37
7-8	Filter Element Installation .....	7-41
7-9	Non-Cleanable Filter Elements .....	7-42
7-10	<b>P</b> Accumulator and Lockout Valve Installation .....	7-43
7-11	Work Aid for Dual Hydraulic Cylinder Removal and Installation .....	7-46
7-12	Dual Hydraulic Cylinder .....	7-47
7-13	Tool Application - Cylinder Assembly Torque Fixture, Part Numbers T41000310-1 and T100619-2 .....	7-49
7-14	Damage Limits for Hydraulic Cylinder Bearing Housing .....	7-52
7-15	Dual Hydraulic Cylinder Assembly (Typical) .....	7-53
7-16	Flight Control Hydraulic Cylinder and Servo Actuator Valve .....	7-55
7-17	<b>P</b> Dual Hydraulic Cylinder Valve Connections .....	7-59
7-18	Dual Hydraulic Cylinders to Swashplate and Collective Lever Installation .....	7-61
7-19	Dual Hydraulic Cylinder Servo Valve Installation .....	7-62
7-20	(SCAS) Servo Actuator Assembly .....	7-63
7-21	Tail Rotor Control Cylinder and Support Installation .....	7-66
7-22	Tail Rotor Control Cylinder and Support Assembly .....	7-67
7-22.1	Hydraulic Servocylinder, Part No. 1660 Series (Typical), Exploded View .....	7-68.4

**LIST OF ILLUSTRATIONS (CONT)**

NUMBER	TITLE	PAGE
7-22.2	Hydraulic Servocylinder, Part No. 1660 Series (Typical), Exploded View .....	7-68.6
7-23	Solenoid Valve P/N 204-076-504-3 Installation .....	7-73
7-24	Solenoid Valve P/N 204-076-504-3 FSCM 94641 P/N 1-U-1025-63 Assembly .....	7-75
7-25	Functional Test Setup for Solenoid Valve P/N 204-076-504-3 FSCM 94641 P/N 1-U-1025-63 .....	7-80
7-26	Flow Diagram for Solenoid Valve P/N 204-076-504-3 FSCM 94641 P/N 1-U-1025-63 . Pressure Drop Test Setup for Solenoid Valve P/N 204-076-504-3 FSCM 94641 P/N 1-U-1025-63 .....	7-81
7-27	7-28	7-81
7-28	Solenoid Valves (SCAS System) - Installation .....	7-84
7-29	<b>P</b> Solenoid Valve P/N 7U7464 Installation .....	7-92
7-30	<b>P</b> Solenoid Valve P/N 7U7464 Assembly .....	7-95
7-31	<b>P</b> Functional Test Setup for Solenoid Valve P/N 7U7464 .....	7-98
7-32	<b>P</b> Flow Diagram for Solenoid Valve P/N 7U7464 .....	7-98
7-33	<b>P</b> Pressure Drop Test Setup for Solenoid Valve P/N 7U7464 .....	7-99
7-34	Servo Actuator (Electrohydraulic) - Wing Pylon Armament .....	7-102
7-35	Work Aid for Wing Pylon Armament Servo Actuator Disassembly Assembly .....	7-104
7-36	Work Aid for Seal Installation on Wing Pylon Armament Servo Actuator .....	7-105
7-37	Sheet for Recording Test Data for Wing Pylon Armament Servo Actuator .....	7-107
7-38	Schematic Diagram Wing Pylon Armament Servo Actuator Connections for Bench Test .	7-108
7-39	Tool Application Wing Pylon Armament Servo Actuator Test Fixture .....	7-109
7-40	<b>E M</b> Hydraulic System .....	7-111
7-41	<b>E M</b> Emergency (Electric) Motor Driven Hydraulic System .....	7-117
7-42	<b>E M</b> Solenoid Valves P/N 204-076-504-3 Installation .....	7-144
7-43	<b>E M</b> Solenoid Valves (SCAS System) - Installation .....	7-149
8-1	<b>P E</b> Instrument System Equipment Location .....	8-2
8-2	Pitot - Static System .....	8-26.3
8-2.1	Connection for Pitot Leak Check (Typical) .....	8-26.4
8-2.2	Connection for Static Leak Check (Typical) .....	8-26.5
8-3	Test Circuit Setup for Fuel Tank Unit Capacitance and Resistance Tests .....	8-42
8-4	Test Circuit Setup for Fuel Quantity Indicator Bench Test .....	8-43
8-5	Circuit Arrangement and Adapter Cable for Fuel Quantity Adjustment Procedures on Installed System .....	8-44
8-5.1	Fuel Quantity Test Set P/N PSD60-1AF .....	8-44.4
8-5.2	Fuel Quantity "T" Cable P/N PSDAF-537 .....	8-44.5
8-5.3	Fuel Quantity Calibration Worksheet .....	8-44.6
8-6	Volt-Ammeter Test Set-up .....	8-49
9-1	<b>P</b> Simplified Electrical Bus Wiring Schematic .....	9-2
9-2	<b>E M</b> Simplified Electrical Bus Wiring Schematic .....	9-3
9-3	<b>P</b> Electrical Equipment Location Forward Section .....	9-4
9-4	<b>P</b> Electrical Equipment Location Pilot Section .....	9-6

LIST OF ILLUSTRATIONS (CON'T)

NUMBER	TITLE	PAGE
9-5	<b>P</b> Electrical Equipment Location Gunner Section .....	9-8
9-6	<b>E</b> Electrical Equipment Location Aft Section .....	9-10
9-7	<b>E</b> Electrical Equipment Location Forward Section .....	9-13
9-8	<b>E</b> Electrical Equipment Location Pilot Section .....	9-13
9-9	<b>E</b> Electrical Equipment Location Gunner Section .....	9-18
9-10	<b>E</b> Electrical Equipment Location Aft Section .....	9-20
9-11	Environmental Connector Test Adapter .....	9-23
9-12	<b>P</b> Standby Inverter Adjustment .....	9-66
9-13	<b>P</b> Pilot Caution Panel .....	9-80.1
9-14	<b>E</b> Pilot Caution Panel .....	9-80.1
9-14.1	Deleted	
9-15	<b>M</b> Pilot Caution Panel .....	9-81
9-15.1	Deleted	
9-16	<b>P</b> Gunner Caution Panel .....	9-82.1
9-17	<b>E M</b> Gunner Caution Panel .....	9-82.1
9-17.1	Deleted	
9-17.2	Pilots Caution Panel Assembly .....	9-88.7
9-17.3	Pilots Caution Panel Subassembly .....	9-88.8
9-17.4	Housing Subassembly .....	9-88.11
9-17.5	Cover Assembly .....	9-88.11
9-17.6	Indicating Light Circuit Card .....	9-88.12
9-17.7	Contact Assembly .....	9-88.16
9-17.8	Polarizing Keys Location .....	9-88.17
9-17.9	Removal of Finish for Electrical Bonding .....	9-88.19



## LIST OF ILLUSTRATIONS (CON'T)

NUMBER	TITLE	PAGE
9-17.10	Position of Contacts in Latch Base . . . . .	9-88 .23
9-17.11	Gunners Caution Panel Schematic Diagram . . . . .	9-88.25
9-17.12	Gunners Caution Panel . . . . .	9-88.32
9-17.13	Gunners Caution Panel Wiring Connections . . . . .	9-88.35
9-18	BHC Model RPM Warning Control.. . . . .	9-18.1
9-18.1	Saturn Model RPM Limit Warning Detector . . . . .	9-18.1
9-18.2	Cables for Alignment of RPM Limit Warning Detector . . . . .	9-92.2
9-18.3	Bench Test Set Up for BHT 205-074-033-101 RPM Limit Warning Detector . . . . .	9-93
9-19	<b>P</b> Armament Equipment Location . . . . .	9-128
9-20	<b>P</b> TOW Missile Launcher Positions . . . . .	9-131
9-21	<b>P</b> Wing Stores Armament Test Panel . . . . .	9-139
9-22	<b>P</b> Wing Stores Armament Test Panel Schematic . . . . .	9-140
9-23	<b>F</b> Armament Equipment Location . . . . .	9-155
9-24	<b>E</b> TOW Missile Launcher Positions . . . . .	9-164
9-25	<b>E</b> DU Digital Display Test . . . . .	9-173
9-26	<b>E</b> LRU Fault Identification and Location Test . . . . .	9-173
9-27	<b>E</b> XM18 Minigun Circuitry Test Panel . . . . .	9-175
9-28	<b>E</b> Wing Stores Circuitry Test Panel . . . . .	9-180
9-29	<b>M</b> TOW Missile Launcher Positions . . . . .	9-195
9-30	<b>M</b> DU Digital Display Test, . . . . .	9-204
9-31	<b>M</b> LRU Fault Identification and Location Test . . . . .	9-204
9-32	<b>M</b> XM18 Minigun Circuitry Test Panel . . . . .	9-206
9-33	<b>M</b> Wing Stores Circuitry Test Panel . . . . .	9-211
10-1	Fuel Systems Schematic . . . . .	10-3
10-2	Fuel System . . . . .	10-4
10-3	Fuel Shutoff Valve . . . . .	10-9
10-4	Fuel Boost Pump . . . . .	10-12.1
10-4.1	Fuel Boost Pump Cartridge . . . . .	10-12.2
10-4.2	Work Aid for Fuel Pump Cartridge Removal . . . . .	10-12.3
10-5	Collapsing Forward Fuel Cell . . . . .	10-22
10-6	Installed Forward Fuel Cell . . . . .	10-24
10-7	Collapsing Aft Fuel Cell..... . . . .	10-26
11-1	Collective Controls . . . . .	11-4
11-2	Pilot Collective Stick installation . . . . .	11-8
11-3	Pilot Collective Stick Assembly . . . . .	11-9
11-4	Bearing installation -Pilot Throttle Grip . . . . .	11-14
11-5	Friction Lining Repair . . . . .	11-16
11-6	Throttle Lever Bearing installation . . . . .	11-17
11-7	Collective Friction Tube Repairs . . . . .	11-18
11-8	Pilot Collective Stick Adjustments . . . . .	11-20
11-9	Gunner Collective Stick installation . . . . .	11-22
11-10	Gunner Collective Stick-Assembly . . . . .	11-25
11-11	Gunner Collective Stick Adjustment . . . . .	11-27
11-12	Force-And-Aft Cyclic Controls . . . . .	11-30
11-13	Lateral Cyclic Controls . . . . .	11-32
11-14	Work Aid for Rigging Swashplate. . . . .	11-34

LIST OF ILLUSTRATIONS (CON'T)

NUMBER	TITLE	PAGE
11-15	Swashplate Rigging Dimensions . . . . .	11-35
11-16	Pilot Cyclic Stick Installation . . . . .	11-36
11-17	Pilot Cyclic Stick Assembly . . . . .	11-40
11-18	Collar and Bushing Installation . . . . .	11-42
11-19	Pilot Cyclic Stick Friction Adjustment . . . . .	11-44
11-20	Gunner Cyclic Stick Installation . . . . .	11-46
11-21	Gunner Cyclic Stick Assembly . . . . .	11-48
11-22	Fore-And-Aft Cyclic Jackshaft Installation . . . . .	11-51
11-23	Force Gradient Assembly . . . . .	11-56.1
11-24	Tail Rotor Controls . . . . .	11-57
11-25	Tail Rotor Pedal Installation . . . . .	11-62
11-26	<b>P</b> † Stability and Control Augmentation System (SCAS) . . . . .	11-70
11-27	<b>E M</b> Stability and Control Augmentation System (SCAS) . . . . .	11-71
11-27.1	SCAS Transducer Calibration . . . . .	11-74.2
11-28	Elevator Control System . . . . .	11-76
11-29	Elevator Installation . . . . .	11-79
11-30	Damage Limits - Fixed Length Flight Control Tubes and Links (Typical) . . . . .	11-82
11-31	Control System Linkage Installation . . . . .	11-85
11-32	Damage Limits - Anti-Torque System . . . . .	11-95
11-33	Damage Limits - Elevator Control System . . . . .	11-102
11-34	Damage Limits - Collective Control System . . . . .	11-104
11-35	Damage Limits - Cyclic Control System . . . . .	11-110
11-36	Flight Control System Bearings . . . . .	11-118
11-37	Lateral Cyclic and Collective Controls Power Cylinder Support Installation . . . . .	11-119
11-38	Fore-And-Aft Cyclic Controls Power Cylinder Support Installation . . . . .	11-120
11-39	Damage Limits - Power Cylinder Supports . . . . .	11-121
12-1	Engine Fire Detection System . . . . .	12-3
12-2	Low G Warning System . . . . .	12-5
12-3	Low G Warning Assembly 8A10 . . . . .	12-9
12-4	Accelerometer 8A 111 . . . . .	12-10
12-5	Low G Warning Light/Switch 8DS25 . . . . .	12-12
12-6	Converter 8M1 . . . . .	12-13
13-1	Environmental Control System . . . . .	13-3
13-2	Environmental Control Unit . . . . .	13-5
13-3	Environmental Control System Schematic . . . . .	13-7
13-4	Temperature Control Valve . . . . .	13-8
13-5	Temperature Control Valve Schematic . . . . .	13-9
13-6	ECU Cooling Turbine . . . . .	13-12
13-6.1	ECU Cooling Turbine Lubrication . . . . .	13-12.1
13-7	Pressure Regulator and Shutoff Valve . . . . .	13-14
13-8	Pressure Regulator and Shutoff Valve Schematic . . . . .	13-16
13-9	Blower Impeller Assembly . . . . .	13-18
13-10	Vent Air Control Valve - Installation . . . . .	13-21
13-11	Vent Air Control Valve . . . . .	13-22
13-12	Vent Air Control Valve Test Set-Up . . . . .	13-24
13-13	Rain Removal Manifold . . . . .	13-28
13-14	Rain Removal Thermal Switch-Installation . . . . .	13-30
13-15	Rain Removal Nozzle and Cleared Air Pattern . . . . .	13-31
13-16	Rain Removal Valve . . . . .	13-34
13-17	Limits Chart -Air Distribution Valve . . . . .	13-36
13-18	Tool Application - Teflon Lip Seal Installation . . . . .	13-38
16-1	<b>E M</b> Turret Installation . . . . .	16-4
16-2	Special Tools for Ejector Racks . . . . .	16-12

LIST OF ILLUSTRATIONS (CON'T)

NUMBER	TITLE	PAGE
16-3	Outboard Ejector Rack Installation . . . . .	16-21
16-4	Ejector Rack Alignment . . . . .	16-24
16-5	Outboard Ejector Rack Assembly . . . . .	16-27
16-6	Inboard Ejector Rack Installation. . . . .	16-32
16-6.1	Contact Profusion Inside Breech . . . . .	16-32.1
16-6.2	Wiring Harness Assembly . . . . .	16-32.2
16-7	Inboard Ejector Rack Assembly . . . . .	16-34
16-8	Wing Stores Pylon and Fairings . . . . .	16-35
16-9	<b>M</b> AIM-1/EXL Laser Installation.... . . . .	16-38
17-1	Canopy Removal System . . . . .	17-2
17-2	Damage Limits- Linear Shaped Charge Assembly . . . . .	17-4
C-1	Inventory Item List . . . . .	C-3
F-1	Wiring Identification Chart.... . . . .	F-5
F-1.1	Symbols Chart . . . . .	F-6
F-1.2	<b>P</b> Altimeter Vibrator System Wiring Diagram . . . . .	F-45
F-2	<b>P</b> External Power System Wiring Diagram . . . . .	F-47
F-3	<b>P</b> Starter System Wiring Diagram . . . . .	F-49
F-4	<b>P</b> Ignition System Wiring Diagram . . . . .	F-50
F-5	<b>P</b> Anticollision and Position Lights System Wiring Diagram . . . . .	F-51
F-6	<b>P</b> Searchlight System Wiring Diagram . . . . .	F-52
F-7	<b>P</b> Engine De-Ice System Wiring Diagram. . . . .	F-53
F-8	<b>P</b> Fuel Valve and Oil Valve System Wiring Diagram . . . . .	F-54
F-9	<b>P</b> Fuel Boost System Wiring Diagram. . . . .	F-55
F-10	<b>P</b> Governor Control System Wiring System . . . . .	F-56
F-11	<b>P</b> Idle Stop System Wiring Diagram . . . . .	F-57
F-12	<b>P</b> Force Trim System Wiring Diagram . . . . .	F-58
F-13	<b>P</b> Environmental Control System Wiring Diagram, . . . . .	F-59
F-14	<b>P</b> Pitot Heater System Wiring Diagram . . . . .	F-60
F-15	<b>P</b> TOW Blower Cooling System Wiring Diagram . . . . .	F-61
F-16	<b>P</b> Attitude Indicating System Wiring Diagram . . . . .	F-63
F-17	<b>P</b> FUEL Quantity Indicating System Wiring Diagram . . . . .	F-64
F17.1	<b>P</b> Turn and Slip Indicating System Wiring Diagram . . . . .	F-65
F-18	<b>P</b> Radio Blower Cooling System Wiring Diagram . . . . .	F-65
F-18 1	<b>P</b> Armament Relay Lucatlon. . . . .	F-66
F-19	<b>E</b> AC Electrical Load Chart . . . . .	F-67
F-20	<b>E</b> Altimeter Vibrator System Wiring Diagram . . . . .	F-83
F-21	<b>E</b> External Power System Wiring Diagram . . . . .	F-85
F-22	<b>E</b> Starter System Wiring Diagram . . . . .	F-87
F-23	<b>E</b> Searchlight System Wiring Diagram . . . . .	F-89
F-24	<b>E</b> Engine De. Ice System Wiring Diagram . . . . .	F-90
F-25	<b>E</b> Fuel Valve and Engine Oil Valve System Wiring Diagram . . . . .	F-91
F-26	<b>E</b> Fuel Boost System Wiring Diagram . . . . .	F-92
F-27	<b>E</b> Governor Control System Wiring Diagram . . . . .	F-93
F-28	<b>E</b> Idle Stop System Wiring Diagram . . . . .	F-94
F-29	<b>E</b> Force Trim System Wiring Diagram . . . . .	F-95
F-30	<b>E</b> Environmental Control System Wiring Diagram. . . . .	F-97
F-31	<b>E</b> Pitot Heater System Wiring Diagram . . . . .	F-98
F-32	<b>E</b> TOWBlower Cooling System Wiring Diagram . . . . .	F-99
F-33	<b>E</b> Radio Blower Cooling System Wiring Diagram . . . . .	F-100
F-34	<b>E</b> Attitude Indicating System Wiring Diagram . . . . .	F-10I
F-35	<b>E</b> Fuel Quantity Indicating System Wiring Diagram . . . . .	F-102
F-36	<b>E</b> Tachometer Indicating System Wiring Diagram . . . . .	F-103
F-36.1	<b>E</b> Centrisep Particle Separator Wiring Diagram (After Incorporation of MW0 55-1520-236-50-12) . . . . .	F-104

LIST OF ILLUSTRATIONS (CON'T)

NUMBER	TITLE	PAGE
F-37	<b>E</b> Turn and Slip Indicating System Wiring Diagram.....	F-105
F-38	<b>E</b> Electrical Equipment Component Replacement Wiring Diagram . . . . .	F-106
F-38.1	<b>E</b> Armament Relay Location . . . . .	F-106.1
F-39	<b>M</b> AC Electrical Load Chart . . . . .	F-108
F40	<b>M</b> DC Electrical Load Chart . . . . .	F-109
F-41	<b>M</b> Tachometer Indicating System . . . . .	F-110
F-42	<b>M</b> Pressure Indicating Systems . . . . .	F-121
F-43	<b>M</b> Temperature Indicating Systems . . . . .	F-131
F-44	<b>M</b> Attitude Indicating System (Equipment Location) . . . . .	F-141
F-45	<b>M</b> Turn and Slip Indicating System . . . . .	F-147
F-46	<b>M</b> Fuel Quantity Indicating System . . . . .	F-151
F-47	<b>M</b> Altimeter Vibrator System . . . . .	F-160
F-48	<b>M</b> DC Generator Power System (Equipment Location) . . . . .	F-167
F-49	<b>M</b> Battery System (Equipment Location) . . . . .	F-177
F-50	<b>M</b> External Power Provisions . . . . .	F-184
F-51	<b>M</b> DC Power Distribution and Interconnect Logic (Equipment Location) . . . . .	F-189
F-52	<b>M</b> AC Power System (Equipment Location) . . . . .	F-197
F-53	<b>M</b> Stafier System . . . . .	F-207
F-54	<b>M</b> IgnitionSystem . . . . .	F-213
F-55	<b>M</b> Interior Lights System (Equipment Location) . . . . .	F-221
F-56	<b>M</b> Caution Lights System (Equipment Location) . . . . .	F-235
F-57	<b>M</b> RPM Limit Warning System (Equipment Location) . . . . .	F-259
F-58	<b>M</b> Position Lights System . . . . .	F-269
F-59	<b>M</b> Anticollision Light System . . . . .	F-276
F-60	<b>M</b> Searchlight System . . . . .	F-279
F-61	<b>M</b> Engine De-Ice System . . . . .	F-284
F-62	<b>M</b> Fuel Valve and Engine Oil Bypass Valve Systems . . . . .	F-292
F-63	<b>M</b> Fuel Boost System . . . . .	F-300
F-64	<b>M</b> Governor Control System . . . . .	F-307
F-65	<b>M</b> Idle Stop System . . . . .	F-316
F-66	<b>M</b> Force Trim System . . . . .	F-322
F-67	<b>M</b> Hydraulic Control System (Equipment Location) . . . . .	F-331
F-68	<b>M</b> Environmental Control System . . . . .	F-341
F-69	<b>M</b> Pitot Heater System . . . . .	F-350
F-70	<b>M</b> TOW Blower Cooling System . . . . .	F-354
F-71	<b>M</b> Radio Blower Cooling System . . . . .	F-361
F-71.1	<b>M</b> Centrisep Particle Separator Wiring Diagram (After Incorporation of MWO 55-1520-236-50-12) . . . . .	F-366.1
F-72	<b>M</b> Universal Turret Subsystem (Equipment Location) . . . . .	F-367
F-73	<b>M</b> TOW Missile Armament Subsystem (Equipment Location) . . . . .	F-383
F-74	<b>M</b> Fire Control System (Equipment Location) . . . . .	F-399
F-75	<b>M</b> Wing Stores Armament Subsystem (Equipment Location) . . . . .	F-413
F-76	<b>M</b> Electricd Equipment Component Replacment . . . . .	F-425
F-77	<b>M</b> Electrical Equipment Component Replacement (After MWO 55-1520-236-50-4) . . .	F-466
F-78	<b>MCN</b> C-NITE Subsystem (Equipment Location) . . . . .	F-469
F-79	<b>MCN</b> C-NITE Electrical Equipment Component Replacement . . . . .	F-471
F-80	<b>MCN</b> FLIR Subsystem Jumper Cable Assemblies . . . . .	F-472
FO-1	<b>P</b> Hydraulic System Schematic . . . . .	FO-1
FO-2	<b>E M</b> Hydraulic System Schematic . . . . .	FO-2
FO-3	Balancer and Strobex Description . . . . .	FO-3
FO-4	<b>P</b> AC Electricl Load Chart . . . . .	FO-4
FO-5	<b>P</b> AC Electricd Load Chart . . . . .	FO-5
FO-6	<b>P</b> ACElecWicd Load Chart . . . . .	FO-6



LIST OF ILLUSTRATIONS (CON'T)

NUMBER	TITLE	PAGE
FO-7	<b>P</b> AC Electrical Load Chart .....	FO-7
FO-8	<b>P</b> DC Electrical Load Chart .....	FO-8
FO-9	<b>P</b> DC Electrical Load Chart .....	FO-9
FO-10	<b>P</b> DC Electrical Load Chart .....	FO-10
FO-11	<b>P</b> DC Electrical Load Chart .....	FO-11
FO-12	<b>P</b> DC Electrical Load Chart .....	FO-12
FO-13	<b>P</b> DC Electrical Load Chart .....	FO-13
FO-14	<b>P</b> DC Electrical Load Chart .....	FO-14
FO-15	<b>P</b> DC Electrical Load Chart .....	FO-15
FO-16	<b>P</b> DC Electrical Load Chart .....	FO-16
FO-17	<b>P</b> Battery System .....	FO-17



LIST OF ILLUSTRATIONS (CON'T)

NUMBER	TITLE	PAGE
FO-18	<b>P</b> Generator and DC Bus System .....	FO-18
FO-19	<b>P</b> AC Power Supply .....	FO-19
FO-20	<b>P</b> Interior Lights System .....	FO-20
FO-21	<b>P</b> Interior Lights System .....	FO-21
FO.21.1	<b>P</b> Interior Lights System .....	FO.21.1
FO-22	<b>P</b> Interior Lights System .....	FO-22
FO-22.1	<b>P</b> Interior Lights System .....	FO-22.1
FO-23	<b>P</b> Caution Lights System .....	FO-23
FO-24	<b>P</b> Caution Lights System .....	FO-24
FO-25	<b>P</b> RPM Limit Warning System .....	FO-25
FO-26	<b>P</b> Hydraulic Control System .....	FO-26
FO-27	<b>P</b> Armament Turret System .....	FO-27
FO-28	<b>P</b> Armament Turret System .....	FO-28
FO-29	<b>P</b> Armament Turret System .....	FO-29
FO-30	<b>P</b> Armament Wing Stores System .....	FO-30
FO-31	<b>P</b> Armament Wing Stores System .....	FO-31
FO-32	<b>P</b> Armament Wing Stores System .....	FO-32
FO-33	<b>P</b> Armament TOW Missile Wiring Diagram .....	FO-33
FO-34	<b>P</b> Armament TOW Missile Wiring Diagram .....	FO-34
FO-35	<b>P</b> Armament TOW Missile Wiring Diagram .....	FO-35
FO-36	<b>P</b> Armament TOW Missile Wiring Diagram .....	FO-36
FO-37	<b>P</b> Pressure Indicating System .....	FO-37
FO-38	<b>P</b> Tachometer Indicating Systems .....	FO-38
FO-39	<b>P</b> Temperature Indicating Systems .....	FO-39
FO-40	<b>P</b> RPM Limit Warning Test Set Schematic .....	FO-40
FO-41	<b>E</b> AC Electrical Load Chart .....	FO-41
FO-42	<b>E</b> DC Electrical Load Chart .....	FO-42
FO-43	<b>E</b> DC Electrical Load Chart .....	FO-43
FO-44	<b>E</b> Battery System .....	FO-44
FO-45	<b>E</b> DC Generator Power System .....	FO-45
FO-46	<b>E</b> DC Power Distribution and Interconnect Logic .....	FO-46
FO-47	<b>E</b> DC Power Distribution and Interconnect Logic .....	FO-47
FO-48	<b>E</b> AC Power System .....	FO-48
FO-49	<b>E</b> Ignition System .....	FO-49
FO-50	<b>E</b> Interior Lights System .....	FO-50
FO.50.1	<b>E</b> Interior Lights System .....	FO.50.1
FO-51	<b>E</b> Interior Lights System .....	FO-51
FO-51.1	<b>E</b> Interior Lights System .....	FO-51.1
FO-52	<b>E</b> Interior Lights System .....	FO-52
FO-53	<b>E</b> Caution Lights System .....	FO-53
FO-54	<b>E</b> Caution Lights System .....	FO-54
FO-55	<b>E</b> RPM Limit Warning System .....	FO-55
FO-56	<b>E</b> Anticollision and Position Lights System .....	FO-56
FO-57	<b>E</b> Hydraulic Control System .....	FO-57
FO-58	<b>E</b> Turret System .....	FO-58
FO-59	<b>E</b> Turret System .....	FO-59
FO-60	<b>E</b> Turret System .....	FO-60
FO-61	<b>E</b> Turret System .....	FO-61
FO-62	<b>E</b> Turret System .....	FO-62
FO-63	<b>E</b> Turret System .....	FO-63
FO-64	<b>E</b> Turret System .....	FO-64

LIST OF ILLUSTRATIONS (CONT)

NUMBER	TITLE	PAGE
FO-50	<b>E</b> Interior Lights System .....	.FO-50
FO-50.1	<b>E</b> Interior Lights System .....	.FO-50.1
FO-51	<b>E</b> Interior Lights System .....	.FO-51
FO-51.1	<b>E</b> Interior Lights System .....	.FO-51.1
FO-52	<b>E</b> Interior Lights System .....	.FO-52
FO-53	<b>E</b> Caution Lights System .....	.FO-53
FO-54	<b>E</b> Caution Lights System .....	.FO-54
FO-54.1	<b>E</b> Caution Lights System (After Incorporation of MWO 1-1520-236-50-30) .....	.FO-54.1
FO-54.2	<b>E</b> Caution Lights System (After Incorporation of MWO 1-1520-236-50-30) .....	FO-54.2
FO-54.3	<b>E</b> Caution Lights System (After Incorporation of MWO 1-1520-236-50-30) .....	FO-54.3
FO-54.4	<b>E</b> Caution Lights System (After Incorporation of MWO 1-1520-236-50-30) .....	FO-54.4
FO-55	<b>E</b> RPM Limit Warning System .....	.FO-55
FO-56	<b>E</b> Anticollision and Position Lights System .....	.FO-56
FO-57	<b>E</b> Hydraulic Control System .....	.FO-57
FO-58	<b>E</b> Turret System .....	.FO-58
FO-59	<b>E</b> Turret System .....	.FO-59
FO-60	<b>E</b> Turret System .....	.FO-60
FO-61	<b>E</b> Turret System .....	.FO-61
FO-62	<b>E</b> Turret System .....	.FO-62
FO-63	<b>E</b> Turret System .....	.FO-63
FO-64	<b>E</b> Turret System .....	.FO-64
FO-65	<b>E</b> Wing Stores System .....	.FO-65
FO-66	<b>E</b> Wing Stores System .....	.FO-66
FO-67	<b>E</b> Wing Stores System .....	.FO-67
FO-68	<b>E</b> TOW Missile System .....	.FO-68
FO-69	<b>E</b> TOW Missile System .....	FO-69
FO-70	<b>E</b> TOW Missile System .....	.FO-70
FO-71	<b>E</b> TOW Missile System .....	FO-71
FO-72	<b>E</b> TOW Missile System .....	.FO-72
FO-73	<b>E</b> TOW Missile System .....	FO-73
FO-74	<b>E</b> TOW Missile System .....	FO-74
FO-75	<b>E</b> TOW Missile System .....	.FO-75
FO-76	<b>E</b> TOW Missile System .....	.FO-76
FO-77	<b>E</b> TOW Missile System .....	.FO-77

LIST OF ILLUSTRATIONS (CONT)

NUMBER	TITLE	PAGE
FO-78	<b>E</b> Pressure Indicating System . . . . .	.FO-78
FO-79	<b>E</b> Temperature Indicating System . . . . .	.FO-79
FO-80	<b>E</b> Electrical Equipment Component Replacement . . . . .	.FO-80
FO-81	<b>E</b> Electrical Equipment Component Replacement . . . . .	.FO-81
FO-81.1	<b>E</b> Electrical Equipment Component Replacement . . . . .	.FO-81.1
FO-82	<b>E</b> Electrical Equipment Component Replacement . . . . .	.FO-82
FO-83	<b>E</b> Electrical Equipment Component Replacement . . . . .	.FO-83
FO-84	<b>E</b> Electrical Equipment Component Replacement . . . . .	.FO-84
FO-85	<b>E</b> Electrical Equipment Component Replacement . . . . .	.FO-85
FO-86	<b>E</b> Electrical Equipment Component Replacement . . . . .	.FO-86
FO-87	<b>E</b> Electrical Equipment Component Replacement . . . . .	.FO-87
FO-88	<b>E</b> Electrical Equipment Component Replacement . . . . .	.FO-88
FO-89	<b>E</b> Electrical Equipment Component Replacement . . . . .	.FO-89
FO-80	<b>E</b> Electrical Equipment Component Replacement . . . . .	.FO-80
FO-91	<b>M</b> Pressure Indicating System . . . . .	.FO-91
FO-92	<b>M</b> Temperature Indicating Systems . . . . .	.FO-92
FO-93	<b>M</b> Attitude Indicating Systems . . . . .	.FO-93
FO-94	<b>M</b> DC Generator Power System . . . . .	.FO-94
FO-95	<b>M</b> Battery System . . . . .	.FO-95
FO-96	<b>M</b> DC Power Distribution and Interconnect Logic . . . . .	.FO-96
FO-97	<b>M</b> DC Power Distribution and Interconnect Logic . . . . .	.FO-97
FO-98	<b>M</b> AC Power System . . . . .	.FO-98
FO-99	<b>M</b> Ignition System . . . . .	.FO-99
FO-100	<b>M</b> Interior Lights Systems . . . . .	.FO-100
FO-100.1	<b>M</b> Interior Lights Systems . . . . .	.FO-100.1
FO-101	<b>M</b> Interior Lights Systems . . . . .	.FO-101
FO-101.1	<b>M</b> Interior Lights Systems . . . . .	.FO-102
FO-102	<b>M</b> Interior Lights System . . . . .	.FO-102.1
FO-102.1	<b>M</b> Interior Lights System . . . . .	.FO-102.1
FO-103	<b>M</b> Interior Lights System . . . . .	.FO-103
FO-104	<b>M</b> Caution Lights System . . . . .	.FO-104
FO-105	<b>M</b> Caution Lights System . . . . .	.FO-105
FO-106	<b>M</b> RPM Limit Warning System . . . . .	.FO-106
FO-107	<b>M</b> RPM Limit Warning System . . . . .	.FO-107
FO-108	<b>M</b> Hydraulic Control System . . . . .	.FO-108
FO-109	<b>M</b> Universal Turret Subsystem . . . . .	.FO-109
FO-110	<b>M</b> Universal Turret Subsystem . . . . .	.FO-110

LIST OF ILLUSTRATIONS (CONT)

NUMBER	TITLE	PAGE
FO-111	<b>M</b> Universal Turret Subsystem .....	FO-111
FO-112	<b>M</b> Universal Turret Subsystem .....	FO-112
FO-113	<b>M</b> Universal Turret Subsystem .....	FO-113
FO-114	<b>M</b> Universal Turret Subsystem .....	FO-114
FO-115	<b>M</b> Universal Turret Subsystem .....	FO-115
FO-116	<b>M</b> Universal Turret Subsystem .....	FO-116
FO-117	<b>M</b> Universal Turret Subsystem .....	FO-117
FO-118	<b>M</b> Universal Turret Subsystem .....	FO-118
FO-119	<b>M</b> TOW Missile Armament Subsystem .....	FO-119
FO-120	<b>M</b> TOW Missile Armament Subsystem .....	FO-120
FO-121	<b>M</b> TOW Missile Armament Subsystem .....	FO-121
FO-122	<b>M</b> TOW Missile Armament Subsystem .....	FO-122
FO-123	<b>M</b> TOW Missile Armament System .....	FO-123
FO-124	<b>M</b> TOW Missile Armament Subsystem .....	FO-124
FO-125	<b>M</b> TOW Missile Armament .....	FO-125
FO-126	<b>M</b> TOW Missile Armament Subsystem .....	FO-126
FO-127	<b>M</b> TOW Missile Armament Subsystem .....	FO-127
FO-128	<b>M</b> TOW Missile Armament Subsystem .....	FO-128
FO-129	<b>M</b> TOW Missile Armament Subsystem .....	FO-129
FO-130	<b>M</b> Fire Control System .....	FO-130
FO-131	<b>M</b> Fire Control System .....	FO-131
FO-132	<b>M</b> Fire Control System .....	FO-132
FO-133	<b>M</b> Fire Control System .....	FO-133
FO-134	<b>M</b> Wing Stores Armament Subsystem .....	FO-134
FO-135	<b>M</b> Wing Stores Armament Subsystem .....	FO-135
FO-136	<b>M</b> Wing Stores Armament Subsystem .....	FO-136
FO-137	<b>M</b> Electrical Equipment Component Replacement .....	FO-137
FO-138	<b>M</b> Electrical Equipment Component Replacement .....	FO-138
FO-139	<b>M</b> Electrical Equipment Component Replacement .....	FO-139
FO-140	<b>M</b> Electrical Equipment Component Replacement .....	FO-140
FO-141	<b>M</b> Electrical Equipment Component Replacement .....	FO-141
FO-142	<b>M</b> Electrical Equipment Component Replacement .....	FO-142
FO-143	<b>M C N</b> TOW Missile Armament Subsystem .....	FO-143
FO-144	<b>M C N</b> Fire Control System .....	FO-199
FO-145	<b>E M</b> Low G Warning System .....	FO-211
FO-146	<b>M</b> AIM-1/EXL Laser Gunsight System .....	FO-213
FO-147	<b>M</b> GPS Trimpack System .....	FO-215

## LIST OF TABLES

NUMBER	TITLE	PAGE
1-1	Engine Fuel Specifications .....	1-3
1-2	Approved Fuels .....	1-4
1-3	Consumable Maintenance Supplies and Materials .....	1-10.1
1-4	Special Tools and Test Equipment .....	1-19
1-5	Support Equipment .....	1-24.1
1-6	Root Mean Square /Abrasive Grit Equivalency .....	1-24.1
1-7	Deleted	
1-8	Deleted	
1-9	Deleted	
1-10	Deleted	
1-11	Adhesive Mix Ratio, Pot Life, and Cure Cycles .....	1-24.2
1-11.1	Mooring Hardware Chart .....	1-54.1
1-12	Flight Safety Critical Aircraft Parts .....	1-89
2-1	Main Beam Panels (Structural) .....	2-13
2-2	Structural Repair Materials .....	2-17
2-3	Forward Fuselage - Classification of Damage .....	2-26
2-4	Tailboom - Classification of Damage .....	2-69
2-5	Wing - Classification of Damage .....	2-248
4-1	Repair Methods - IR Suppression System (AVIM) .....	4-43
4-1.1	IR Suppressor Damage and Repair Limits (Non Structural Area) .....	4-44.4
4-1.2	IR Suppressor Damage and Repair Limits (Major Structural Elements Only) .....	4-44.8
4-2	Troubleshooting Engine Oil System .....	4-51
4-2.1	Oil Debris Classification Chart .....	4-54.5
4-3	Dimension Tolerance - Turbine Fan .....	4-67
5-1	Difference Between Models .....	5-34
5-1.1	Classification of Damage - K747 Main Rotor Blades .....	5-45
5-1.2	Classification of Damage - K747 Main Rotor Blades .....	5-49
5-2	Plug Patch Data .....	5-58
5-3	Troubleshooting - Tail Rotor System .....	5-140
5-4	Troubleshooting the VIBREX4591 System with the VIBREX Tester, Model 11 .....	5-218
6-1	Troubleshooting - Drive Train System .....	6-2
6-1.1	Oil Debris Classification Chart (Aircraft without ODDS) .....	6-6.2
6-1.2	Oil Debris Classification Chart (Aircraft with ODDS) .....	6-6.4
6-2	Gearbox Oil Debris Classification .....	6-80.1
6-3	Troubleshooting - Transmission Oil System .....	6-122
7-1	Maximum Allowable Leakage for Hydraulic System .....	7-11
7-2	<b>P</b> Emergency Hydraulic System Operational Switching Sequence .....	7-15
7-3	<b>P</b> Troubleshooting of Hydraulic System .....	7-20
7-4	Torque Values for Fluid Connections .....	7-34
7-4.1	Inspection Criteria .....	7-68.3
7-4.2	Troubleshooting Chart .....	7-68.6
7-4.3	Leading Particulars (T/R Control Cylinder) .....	7-68.7
7-5	Leading Particulars for Solenoid Valve P/N 204-076-504-3 FSCM 94641 ( 1-U-1025-63) .....	7-71

LIST OF TABLES (CONT)

NUMBER	TITLE	PAGE
7-6	Non-Destructive Test Requirements for Solenoid Valve P/N 204-076-504-3 FSCM 94641 P/N 1-U-1025-63 (AVIM) .....	7-76
7-7	Diametrical Clearance Requirements for Solenoid Valve P/N 204-076-504-3 FSCM 94641 P/N 1-U-1025-63 (AVIM) .....	7-77
7-8	Troubleshooting During Testing Solenoid Valve P/N 204-076-504-3 FSCM 94641 P/N 1-U-1025-63 (AVIM) .....	7-79
7-9	<b>P</b> Non-Destructive Test Requirements for Solenoid Valve P/N 7U7464 (AVIM) .....	7-94
7-10	<b>P</b> Diametrical Clearance Requirements for Solenoid Valve P/N 7U7464 (AVIM) .....	7-95
7-11	Troubleshooting During Testing of Solenoid Valve P/N 7U7464 (AVIM) .....	7-97
7-12	<b>E M</b> Emergency Hydraulic System Operational Switching Sequence .....	7-122
7-13	<b>E M</b> Troubleshooting Hydraulic System .....	7-125
7-14	Leading Particulars for Solenoid Valve P/N 204-076-504-3 FSCM 94641 P/N 1-U-1025-63 .....	7-142
8-1	Troubleshooting - Tachometer Indicating System .....	8-8
8-2	Troubleshooting - Engine and Transmissiodn Oil Temperature and Pressure indicating System .....	8-14
8-3	Troubleshooting - Turbine Gas Temperature Indicating System .....	8-20
8-4	Troubleshooting - Torque Pressure Indicating System .....	8-22
8-4.1	Tolerance - ( $\pm$ Knots) .....	8-26
8-4.2	Vertical Speed Tolerance Test Scale Accuracy .....	8-26.1
8-4.3	Vertical Speed Tolerance Test Scale Accuracy .....	8-26.1
8-5	Troubleshooting - Airspeed Indicators .....	8-29
8-6	Troubleshooting - Altimeters .....	8-30
8-7	Troubleshooting - Attitude Indicators .....	8-32
8-8	Troubleshooting - Vertical Speed Indicators .....	8-34
8-9	Troubleshooting - Free Air Temperature Gage .....	8-38
8-10	Troubleshooting - Fuel Quantity Indicating System .....	8-39
8-11	Fuel Tank Table of Limits .....	8-43
8-12	Troubleshooting - Voltmeter/Ammeter .....	8-48
8-13	<b>P E</b> Troubleshooting - Pilots Steering Indicator (PSI) .....	8-51
9-1	Troubleshooting - Battery System .....	9-29
9-2	Troubleshooting - External Power System .....	9-34
9-3	<b>P</b> Troubleshooting - Generator and DC Bus System .....	9-37
9-4	<b>P M</b> Troubleshooting - DC Generator Power System .....	9-41
9-4.1	Voltage Regulator Adjustment Settings .....	9-44.2
9-5	<b>P M</b> Troubleshooting - TRU Power System .....	9-46
9-6	<b>P M</b> DC Power Distribution and Interconnect Logic Chart .....	9-49
9-7	<b>P M</b> Troubleshooting - DC Power Distribution and Interconnect Logic .....	9-50
9-8	<b>P</b> Troubleshooting - Inverter System .....	9-58
9-9	<b>P M</b> Troubleshooting - AC Power System .....	9-62
9-10	Troubleshooting - Starting System .....	9-74



NUMBER	TITLE	PAGE
9-11	Troubleshooting - Ignition System . . . . .	9-75
9-12	Troubleshooting - Cockpit Lights . . . . .	9-77
9-12.1	Dimmer Control Input/Output Voltages . . . . .	9-78.1
9-13	Troubleshooting - Console, Engine, Flight, and Tactical Instrument Lights . . . . .	9-79
9-14	Pilot Caution Panel Lights . . . . .	9-83
8-15	Gunners Caution Panel Lights . . . . .	9-83
8-15.1	Troubleshooting Pilots Caution Panel . . . . .	9-88.2
9-15.2	Pilots Caution Panel Wiring Chart . . . . .	9-88.21
9-15.3	Gunners Caution Panel Fault Inputs . . . . .	9-88.27
9-15.4	Troubleshooting - Gunners Caution Panel . . . . .	9-88.28
9-15.5	Gunners Caution Panel Wiring Chart . . . . .	9-88.36
9-16	Troubleshooting -RPM Limit Warning System . . . . .	9-91
6-16.1	Troubleshooting -Skid Landing Light System . . . . .	9-94.1
9-16.2	Troubleshooting - ODDS . . . . .	9-94.3
9-17	Troubleshooting -Position Lights System . . . . .	9-95
9-18	Troubleshooting - Anticollision light . . . . .	9-98
9-19	Troubleshooting - Searchlight System . . . . .	9-100
9-20	Troubleshooting - Transmission Oil Level Light . . . . .	9-102
9-21	Troubleshooting - Engine De-Icing Circuitry . . . . .	9-103
9-22	Troubleshooting - Engine Oil Bypass valve Circuitry . . . . .	9-105
9-23	Troubleshooting - Fuel Valve Circuitry . . . . .	9-106
9-24	Troubleshooting - Fuel Boost Pumps Circuitry . . . . .	9-107
9-25	Troubleshooting - Governor Control Circuitry . . . . .	9-108
9-26	Troubleshooting - Idle Stop Solenoid System Circuitry . . . . .	9-110
9-26.1	<b>E M</b> Troubleshooting Centrifuge Particle Separator Circuitry (After Incorporation of MWO 55-1520-236-50-12 . . . . .	9-110.1
9-27	Troubleshooting -Force Trim System Circuitry . . . . .	9-111
9-28	Troubleshooting -Hydraulic Control System Circuitry . . . . .	9-113
9-29	Troubleshooting -Environmental Control System Circuitry . . . . .	9-115
9-30	Troubleshooting -Pitot Heating System Circuitry . . . . .	9-117
9-31	Troubleshooting -TOW Blower Cooling System . . . . .	9-118
9-32	Troubleshooting -Radio Blower Wing System . . . . .	9-121
9-32.1	<b>P</b> Relay Matrix, Pilot in Control Mode . . . . .	9-122-1
9-32.2	<b>P</b> Relay Matrix, Pilot in Fixed Forward Mode . . . . .	9-122.3
9-32.3	<b>P</b> Relay Matrix, Gunner in Control Mode - HSS controlling Turret . . . . .	9-122-5
9-32.4	<b>P</b> Relay Matrix, Gunner in Control Mode- TSU Controlling Turret . . . . .	9-122.7
9-32.5	<b>P</b> Relay Matrix, Gunner Controlling TOW and Pilot Controlling Turret and Wing Stores Mode . . . . .	9-122.9
9-32.6	<b>P</b> Relay Matrix, TSU Acquisition of Target with Gunner or Pilot HSS Mode . . . . .	9-122.11
9-32.7	<b>P</b> Relay Matrix TSU Acquisition of Target with Gunner or Pilot HSS Mode . . . . .	9-122.13
9-32.8	<b>P</b> Relay Matrix, Gunner Jettison Mode . . . . .	9-122-15

LIST OF TABLES (CONT)

NUMBER	TITLE	PAGE
9-32.9	<b>P</b> Relay Matrix, Pilot Jettison Mode .....	9-122.16
9-33	<b>P</b> Wing Stores Jettison Checklist Chart .....	9-143
9-34	<b>P</b> Troubleshooting - Rocket Launcher Circuitry .....	9-145
9-35	<b>P</b> Troubleshooting - XM-18 Minigun Circuitry .....	9-150
9-36	<b>P</b> Troubleshooting - Wing Stores Jettison Circuitry .....	9-152
9-36.1	<b>E</b> Relay Matrix, Gunner in Control Mode - HSS Controlling Turret .....	9-156.1
8-36.2	<b>E</b> Relay Matrix, Gunner in Control Mode - TSU Controlling Turret .....	9-156.3
8-36.3	<b>E</b> Relay Matrix, Gunner Controlling TOW and Pilot Controlling Turret and Wing Stores Mode .....	9-156.5
9-36.4	<b>E</b> Relay Matrix, Pilot in Control Mode .....	9-156.7
9-36.5	<b>E</b> Relay Matrix, Pilot Override Mode .....	
9-36.6	<b>E</b> Relay Matrix, TSU Acquisition of Target with Gunner or Pilot HSS Mode .....	9-156.11
9-36.7	<b>E</b> Relay Matrix, Gunner Jettison Mode .....	9-156.13
9-36.8	<b>E</b> Relay Matrix, Pilot Jettison Mode .....	9-156.14
9-37	<b>E</b> XM-18 Minigun Checkout Chart .....	9-176
9-38	<b>E</b> Troubleshooting - XM-18 Minigun Circuitry .....	9-177
9-39	<b>E</b> Wing Stores Jettison Checkout Chart .....	9-181
9-40	<b>E</b> Troubleshooting - Wing Stores Jettison Circuitry .....	9-183
9-41	<b>M</b> XM-18 Minigun Checkout Chart .....	9-207
9-42	<b>M</b> Troubleshooting - XM-18 Minigun Circuitry .....	9-208
9-43	<b>M</b> Wing Stores Jettison Checkout Chart .....	9-212
8-44	<b>M</b> Troubleshooting - Wing Stores Jettison Circuitry .....	9-214
10-1	Troubleshooting - Fuel System .....	10-1
11-1	<b>Troubleshooting - Flight Control System</b> .....	11-1
12-1	Troubleshooting - Engine fire Detection System .....	12-1
12-2	<b>Troubleshooting - Low G Warning System</b> .....	12-6
13-1	Troubleshooting-ECU .....	13-1
13-2	Troubleshooting -Rain Removal Valve .....	13-32
16-1	<b>P</b> Troubleshooting Ejector Racks .....	16-13
16-2	<b>E M</b> Troubleshooting Ejector Racks .....	16-16
16-3	<b>M</b> Troubleshooting - AIM-1/EXL Laser Gunsight Subsystem .....	16-39
F-1	<b>P</b> Equipment List (Electrical) .....	F-9
F-2	<b>P</b> Equipment List (Armament) .....	F-15
F-3	<b>E</b> Equipment List (Electrical) .....	F-19
F-4	<b>E</b> Equipment List (Armament) .....	F-26
F-5	<b>M</b> Equipment List (Electrical) .....	F-32
F-6	<b>M</b> Equipment List (Armament) .....	F-39

## CHAPTER 7

## HYDRAULIC AND PNEUMATIC SYSTEM

## 7-1. HYDRAULIC SYSTEM.

## NOTE

Refer to paragraph 7-145 for description of hydraulic system for helicopters coded **E** and helicopters coded **M**.

7-2. **P** DESCRIPTION – HYDRAULIC SYSTEM.

a. Two similar but separate hydraulic systems are used to operate flight control power cylinders, stability and control augmentation system (SCAS) servoactuators, the armament turret, and the TOW missile launcher actuator. A schematic diagram of the hydraulic system for helicopters code **P** is shown on figure FO-1 (foldout page FO-1). System No. 1 and No. 2 are exactly alike as to their reservoirs, transmission driven pumps, and module assemblies which contain system filters, solenoid valves, relief valves and pressure switches for the caution panels. Although both systems operate three dual servo hydraulic cylinders in main rotor controls there is no connection between systems because they separate passages and piston chambers inside each dual cylinder and valve assembly. Both systems and the emergency system also have other hydraulic circuits and functions different and separate from each other.

b. An emergency system is provided to enable the pilot to execute a landing in the event that pressure is lost in both System No. 1 and System No. 2. The emergency systems consists basically of a pressurized lockout valve, a pressure operated shutoff valve, solenoid operated shutoff valve, and check valves. See schematic diagram, figure FO-1 (foldout page FO-1). If the pressure in hydraulic System No. 1 should fall to 650 psig for any reason, the pressurized lockout valve and the pressure operated shutoff valve will close, locking 650 psig on both pressure and return sides of the servo-actuators. This is done to ensure that the actuators remain full of oil and free of air. A small accumulator, 1.0 cubic inch, is connected to the pressurized lockout valve to make up normal leakage of the cyclic actuators and to help maintain the 650 psig trapped in the actuators. The pilot can then move the flight

controls by engaging the mechanical stops on the servo-actuators and moving the cylinders through direct mechanical coupling and internal irreversible valving. When the pilot moves the servo-actuator with no hydraulic pressure available, the fluid is moved from one side of the actuator to the other through flow passages in the actuator head. When the feed-back forces exceed the pressure setting of the differential relief valve, the valve will open, allowing a slight amount of fluid bypass through the actuator pressure to actuator return passages. This will warn the pilot of an overloading condition.

c. An emergency system is provided to furnish hydraulic power to the collective hydraulic cylinder when pressure is lost in System No. 1 and System No. 2. The emergency system consists basically of an electric driven pump, reservoir, solenoid valves, filter, check valves, and pressure switch. The system is also used to power turret and wing, pylon armament systems for boresight capability without hydraulic test stand. The description of the emergency system in paragraph b is applicable to the cyclic control hydraulic cylinders and to the collective control hydraulic cylinder except that when the emergency electric hydraulic pump switch is positioned to "emergency" hydraulic fluid under pressure will be supplied to the collective cylinder. The remainder of System No. 2 will be closed off by solenoid valves. The primary purpose of the emergency systems is to ensure that hydraulic power is furnished to the collective hydraulic cylinder. The pilot cannot maintain collective control without hydraulic pressure at the collective hydraulic cylinder.

d. In the event of a dual hydraulic system and starter/generator failure, the emergency electrical system, with a fully charged battery, is capable of supplying the essential bus loads for at least 17.8 minutes, with the emergency hydraulic pump being used during low speed flight prior to landing, and, during landing operations not to exceed 5 minutes.

7-3. **P** OPERATIONAL CHECK AND TESTING – HYDRAULIC SYSTEM.

The following principles of operation of System No. 1, System No. 2, and emergency system inform the mechanic how each system functions prior to

performing testing and operational checks of hydraulic systems after maintenance requirements have been accomplished.

**a. Principles of Operation (typical for both systems).**

In normal operation of each system, hydraulic fluid is supplied from its nonpressurized reservoir by gravity feed and suction to a transmission-driven pump. The pump is a variable-displacement type with internal pressure compensation, preset to provide **1500** (plus or minus **25**) psi output pressure and **6.1** gpm flow rate at operating rpm, according to system demands. Fluid bypassed in pump, to regulate pressure and flow, is released through a line to the return side of the hydraulic modular unit. Pump output is delivered to the module and passes through the pressure filter. A relief valve in the module guards the system against excessive pressure, relief valve is set to open at **1626 TO 2140** psi. The system solenoid valve is normally de-energized and open to the SYS PRESS outlet of the modular unit but can be electrically energized to bypass position by placing the HYD TEST switch to position marked for opposite system. A pressure switch will cause the caution panel to light if modular unit outlet pressure decreases (at **600 TO 400** psi).

**(1)** Beyond the modular unit, fluid under pressure is delivered through tubes and hoses to three dual hydraulic servo cylinders in main rotor cyclic and collective control systems. Fluid flows into and out of one functional half of each dual cylinder when its servo control valve is moved mechanically by linkage from a control stick, causing the cylinder piston rod to make corresponding movements of linkages to the main rotor. The cylinder valves also have internal functions which tend to prevent feedback of motion from the rotor to the control stick. Either system alone can operate the cylinders, but the dual (or tandem) arrangement is used for added safety of operation.

**(2)** Fluid is returned from power cylinders and other units through external lines to the SYS RET inlet of the module, to pass through the return filter. Normal return flow from module to reservoir is through a hose connected on the quick-disconnect coupling which is at other times used to connect ground test equipment. However, if this hose has not been connected, a low pressure (**45** psi) will open a relief valve and allow flow through another line from the module RES RET outlet to the reservoir BYPASS inlet.

**(3)** Both hydraulic modular units are equipped with quick disconnect couplings to allow ground operation with a portable hydraulic test stand (S2). System operation with such a unit is the same as described for normal operation, except that the reservoir and transmission-driven pump are not being used. External dc power will also be required for electrically operated valves, caution panels, and electric driven hydraulic pump when engine is not operating.

**b. Special Functions of System No. 1.**

In addition to typical operation described in preceding paragraphs for both systems, hydraulic System No. 1 has the following special functions:

**(1)** Tail rotor controls hydraulic cylinder. This is a single hydraulic cylinder and servo valve assembly, mechanically connected into control linkage to the tail rotor.

**(2)** Yaw stability and control augmentation system (SCAS) servo actuator. This circuit includes a pressure line filter, a three-way, two-position solenoid valve, and an electro-hydraulic servo actuator connected in the tail rotor control linkage.

**c. Special Functions of System No. 2.**

In addition to typical operation described for both systems in paragraph 7-2, hydraulic System No. 2 has the following special functions:

**(1)** Armament system hydraulic power provisions (figures 7-1, 7-2, and FO1). This circuit provides pressure and return hydraulic lines to couplings where the M28A1E2 armament turret hydraulic system is connected. The pressure line includes a two-way, two-position solenoid shutoff valve, controlled by the armament panel MASTER ARM switch, a directional flow check valve, and a bypass with a check valve to relieve pressure when solenoid is off. The return line has a directional flow check valve. A bypass line with a relief valve is installed around the flow check valve in the pressure line.

**(2)** Pitch and roll stability and control augmentation system (SCAS) actuators. Circuits are provided for pitch and roll functions of stability augmentation system. Each of the two circuits includes a pressure line filter, a three-way two-position solenoid valve, and an electro-hydraulic

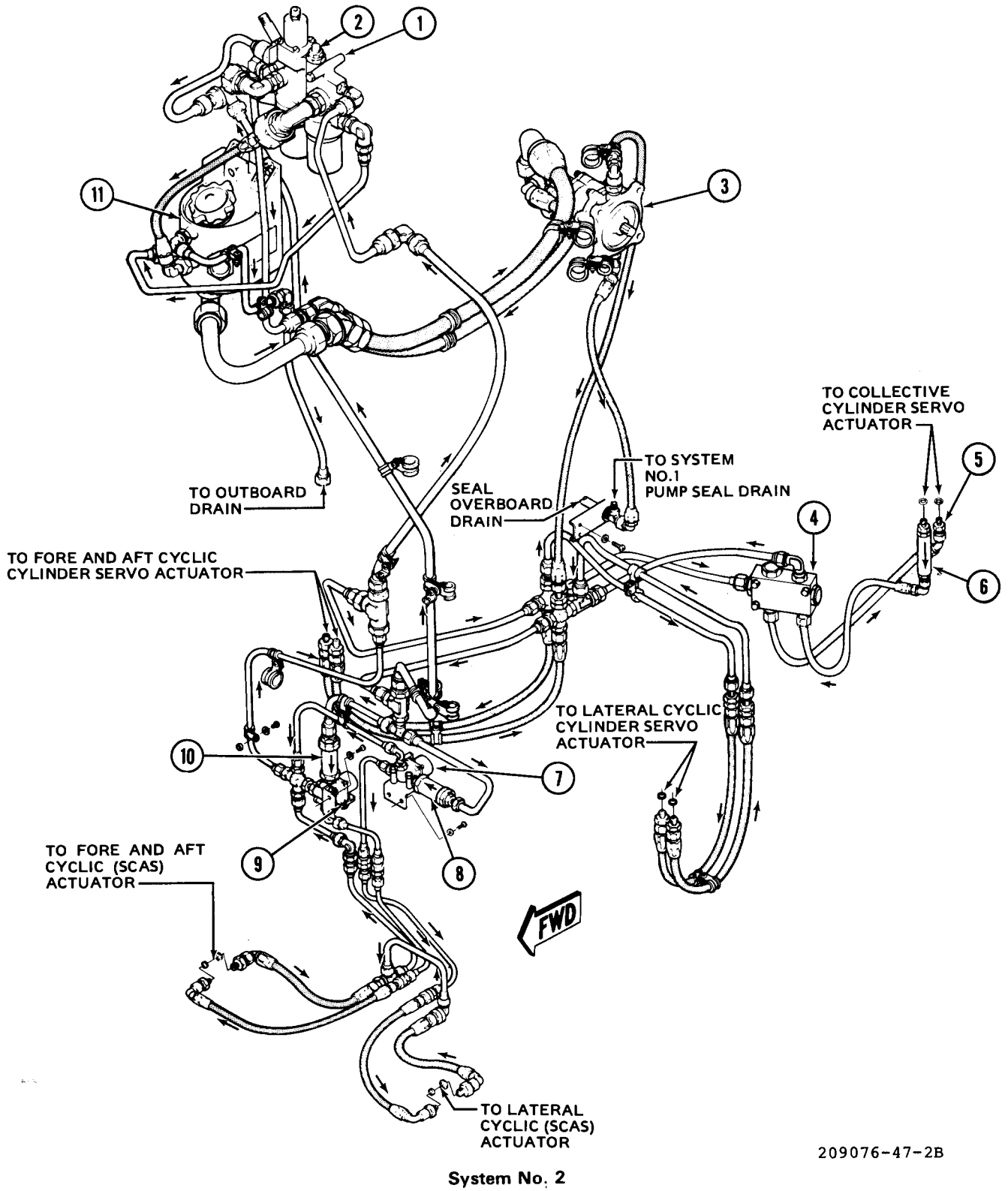

209076-47-2B

Figure 7-1. **P** Hydraulic System (Sheet 1 of 5)

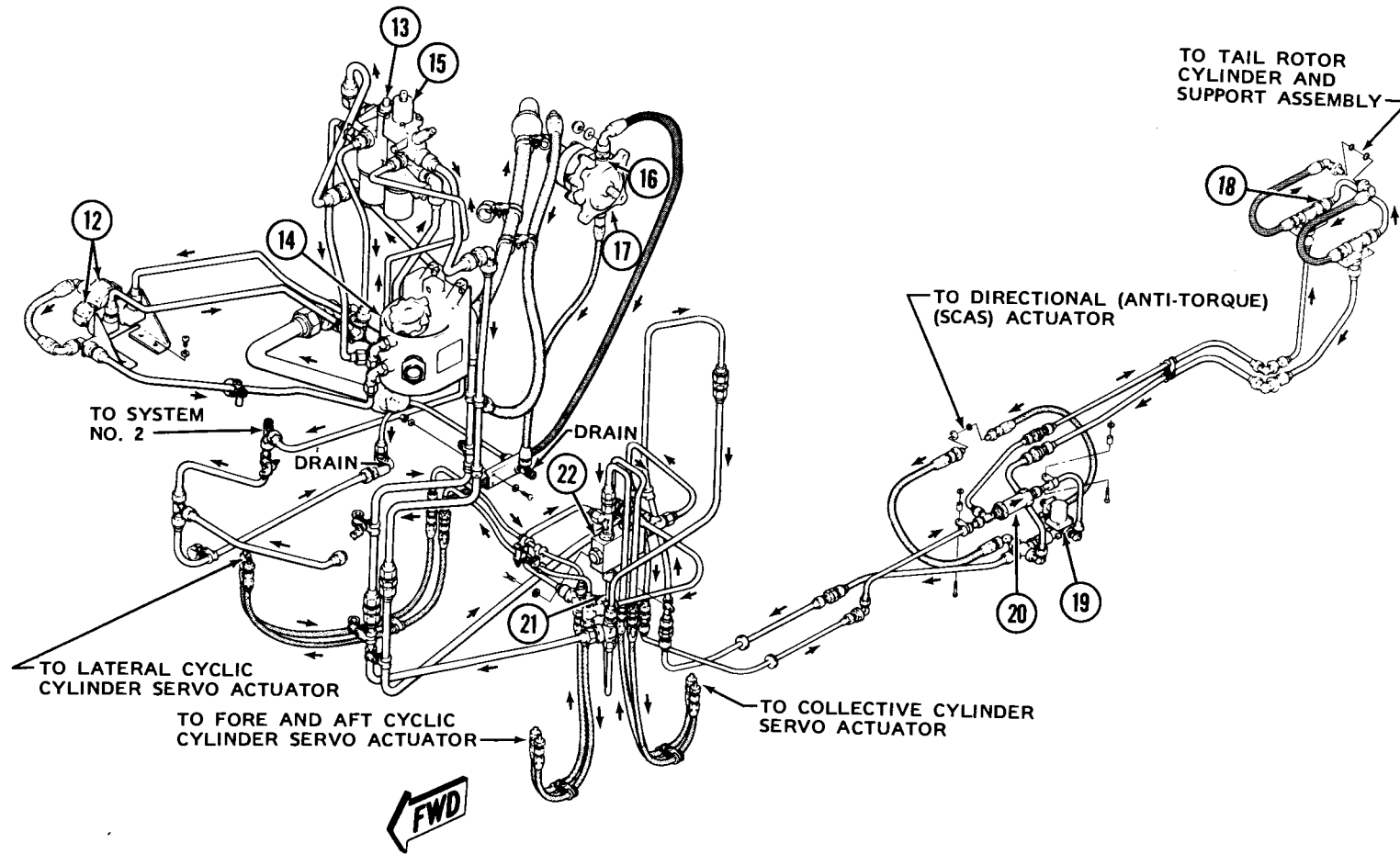

System No. 1

209076-47-1A

Figure 7-1. P Hydraulic System (Sheet 2 of 5)

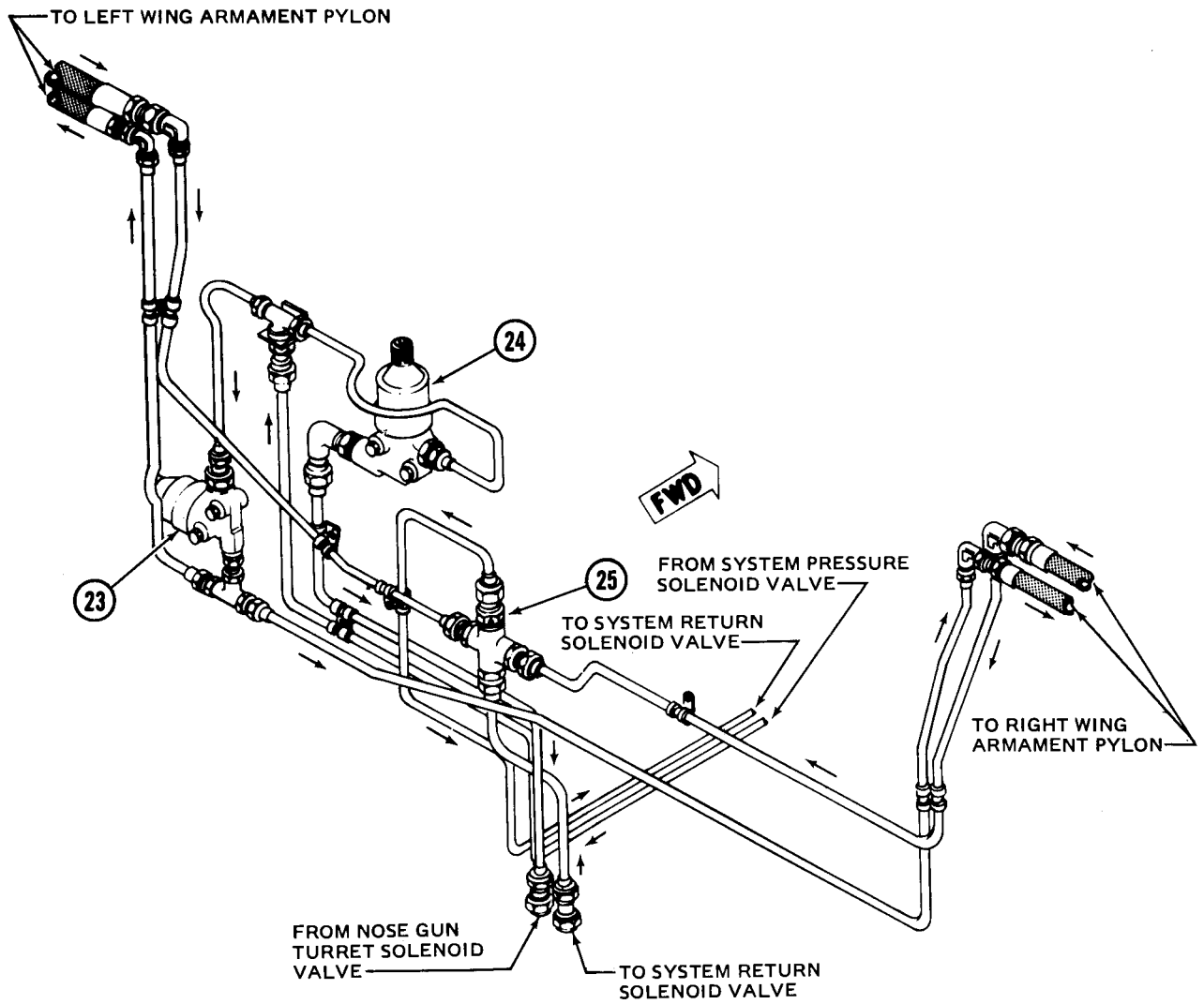

209076-47-4

Figure 7-1. **P** Hydraulic System (Sheet 3 of 5)

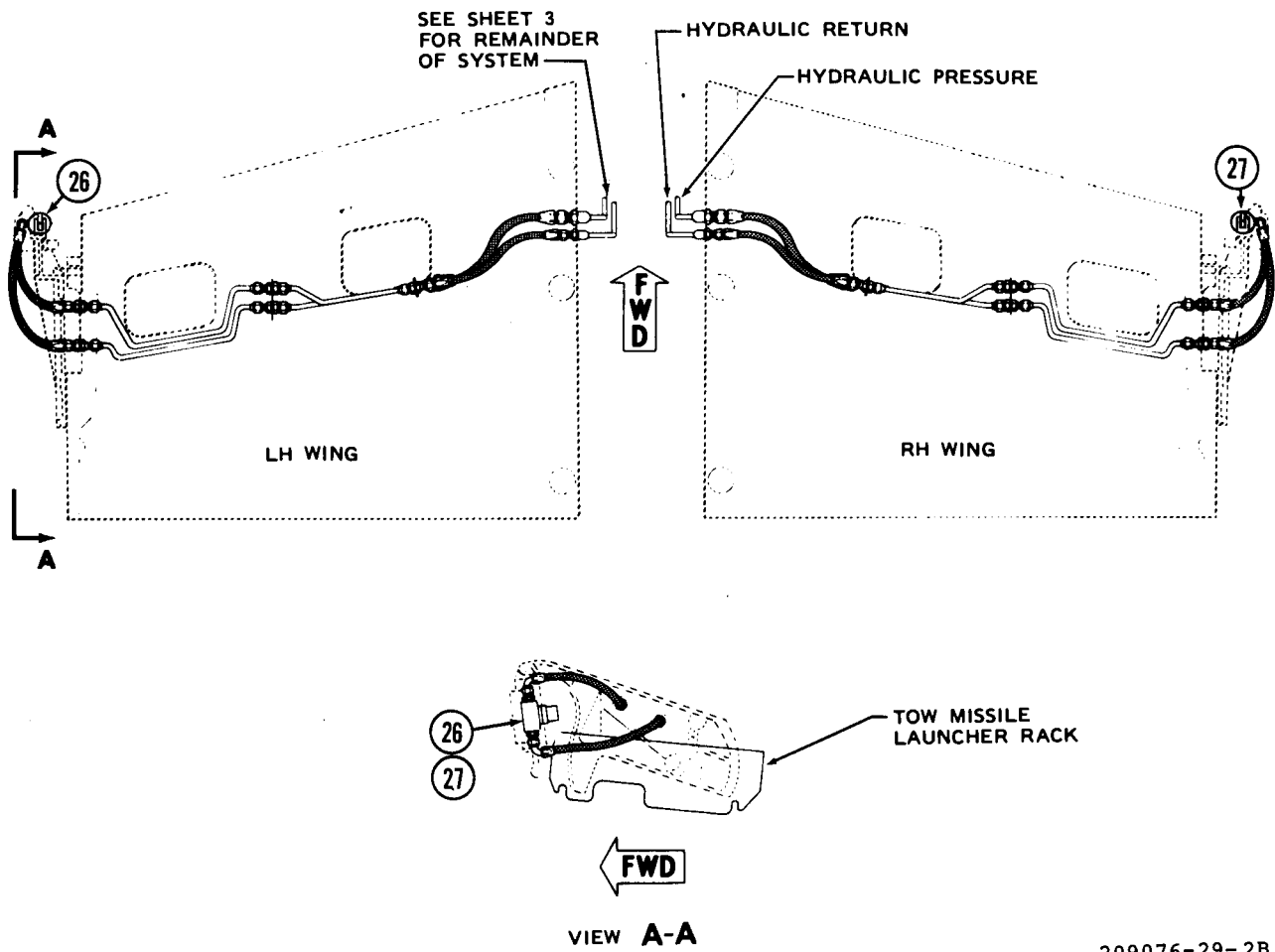

Figure 7-1. **P** Hydraulic System (Sheet 4 of 5)



1. Module assembly
2. Relief valve
3. Pump (system No. 2)
4. Lockout valve
5. Check valve
6. Flow regulator
7. Solenoid valve (lateral cyclic SCAS actuator)  
P/N 209-076-023-1 FSCM 16780 P/N 15353
8. Filter
9. Solenoid valve (fore and aft SCAS actuator)  
P/N 209-076 -023-1 FSCM 16780 P/N 15353
10. Filter
11. Reservoir assembly
12. Test connectors
13. Relief valve
14. Reservoir assembly

15. Module assembly
16. Check valve
17. Pump (system No. 1 )
18. Check valve
19. Solenoid valve (directional SCAS actuator)  
P/N 209-076-023-1 FSCM 16780 P/N 15355
20. Filter
21. Accumulator assembly
22. Lockout valve
23. Solenoid valve (wing armament pylon)  
P/N 7U7464
24. Solenoid valve (nose gun turret)  
P/N 7U7464
25. Check valve
26. Servo actuator
27. Servo actuator

209076-47-5B

Figure 7-1. **P**Hydraulic System (Sheet 5 of 5)

servo actuator connected into the fore-and-aft or lateral cyclic control linkage.

(3) Hydraulic provisions for left and right XM65 TOW missile launchers ejector racks are installed. This circuit provides pressure and return hydraulic lines to a hydraulic servo actuator mounted on each of the TOW missile launcher racks. The master armament switch controls the XM65 TOW missile launcher rack hydraulic servo actuator ON-OFF solenoid valve. The two-way, two-position solenoid valve can be de-energized (turned off) by the gunner pilot override switch.

**d. Ground Testing of Hydraulic Systems with Hydraulic Test Stand (S2).**

The following ground operational check of the three hydraulic systems is to aid in troubleshooting or test for proper functioning of system after maintenance. Whenever possible hydraulic systems should be pressurized simultaneously to avoid introducing air into the unpressurized system. When this is not possible, avoid rapid control movement when operating with a single pressurized system.

(1) Use hydraulic test stand (S2) or provide a similar hydraulic test stand conforming to the following requirements:



**Ensure that fluid in hydraulic test stand is the same type fluid as in the helicopter.**

(a) Thoroughly clean, and service with prescribed hydraulic fluid (C62) or (C61).

(b) Equipped with 10 micron filter in pressure and return lines through which all fluid passes before leaving and returning to unit.

(c) Capable of 2300 psig pressure and at least 6 gpm flow rate.

(d) Having a calibrated pressure gage of 2500 psi minimum capacity.

(e) Pressure and return lines equipped to connect to both hydraulic systems for simultaneous operation.

(2) Visually inspect entire hydraulic system of helicopter to make sure all lines and components are secure and appear capable of operation. Obtain access as follows:

(a) Open left and right doors (8, figure 2-3).

(b) Open left and right transmission cowls (11).

(c) Remove left and right panels (17) attached with cowl fasteners directly below wings at both sides.

(d) Remove panel door, from aft battery compartment on right side of fuselage below tailpipe fairing, for access to tail rotor control power cylinder.

(e) Remove screw-mounted panels from sides of fuselage for access to lines leading to armament hydraulic connections and stability augmentation system actuators.

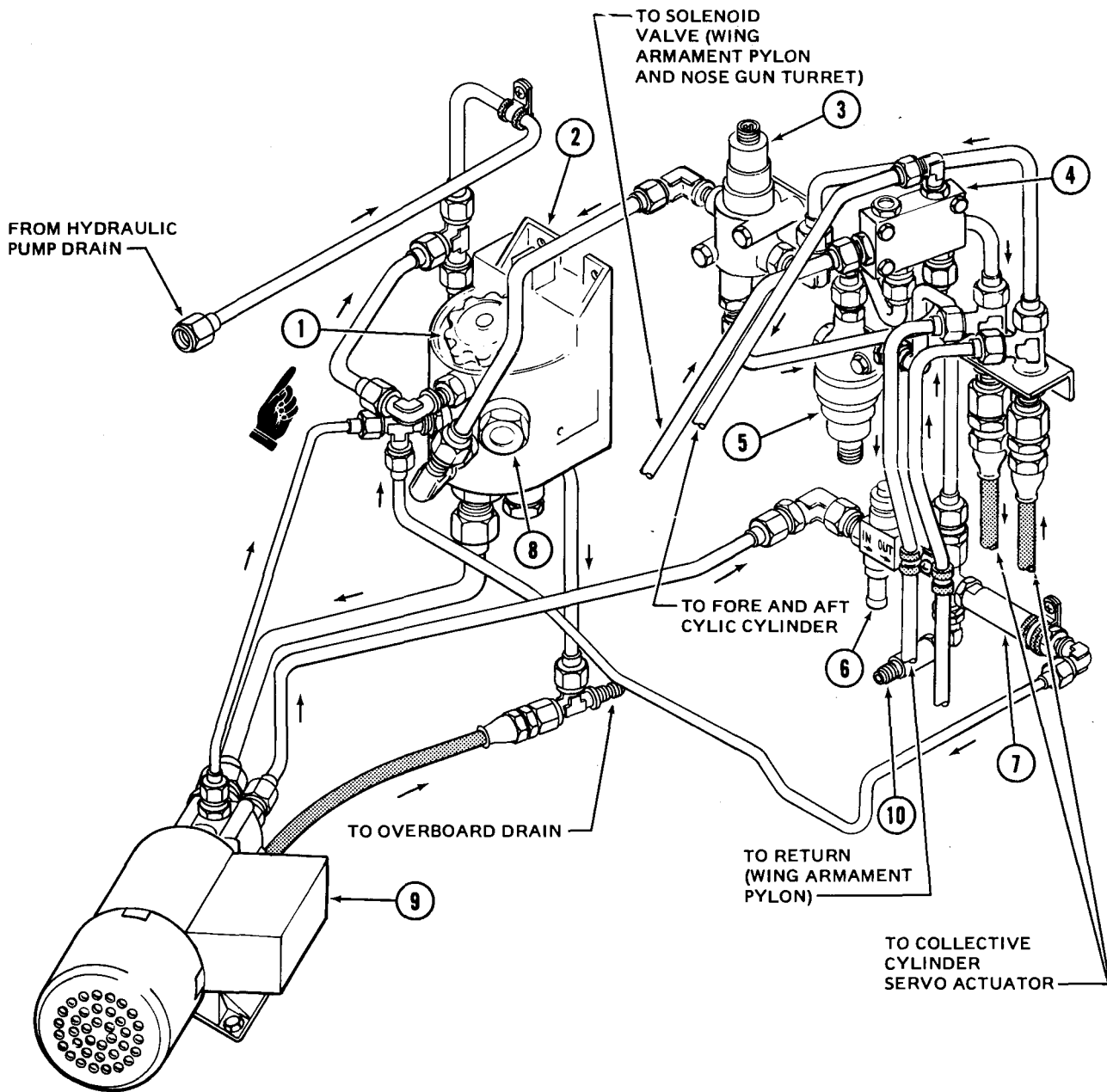

- |   |  |
|---|--|
| <ul style="list-style-type: none"> <li>1. Filler cap</li> <li>2. Reservoir assembly</li> <li>3. Solenoid valve (system return) P/N 204-076 -504-3<br/>FSCM 94641 P/N 1-U-1025-63 or<br/>FSCM 16780 P/N 130027-5</li> <li>4. Lockout valve (system No. 2)</li> <li>5. Solenoid valve (system pressure) P/N 204-076 -504-3<br/>FSCM 94641 P/N 1-U-1025-63 or<br/>FSCM 16780 P/N 130027-5</li> </ul> | <ul style="list-style-type: none"> <li>6. Filter</li> <li>7. Pressure relief valve</li> <li>8. Sight gage</li> <li>9. Emergency hydraulic pump package</li> <li>10. Pressure switch</li> </ul> |
|---|--|

209076-47-3C

Figure 7-2. **P** Emergency (Electric Motor Drive) Hydraulic System

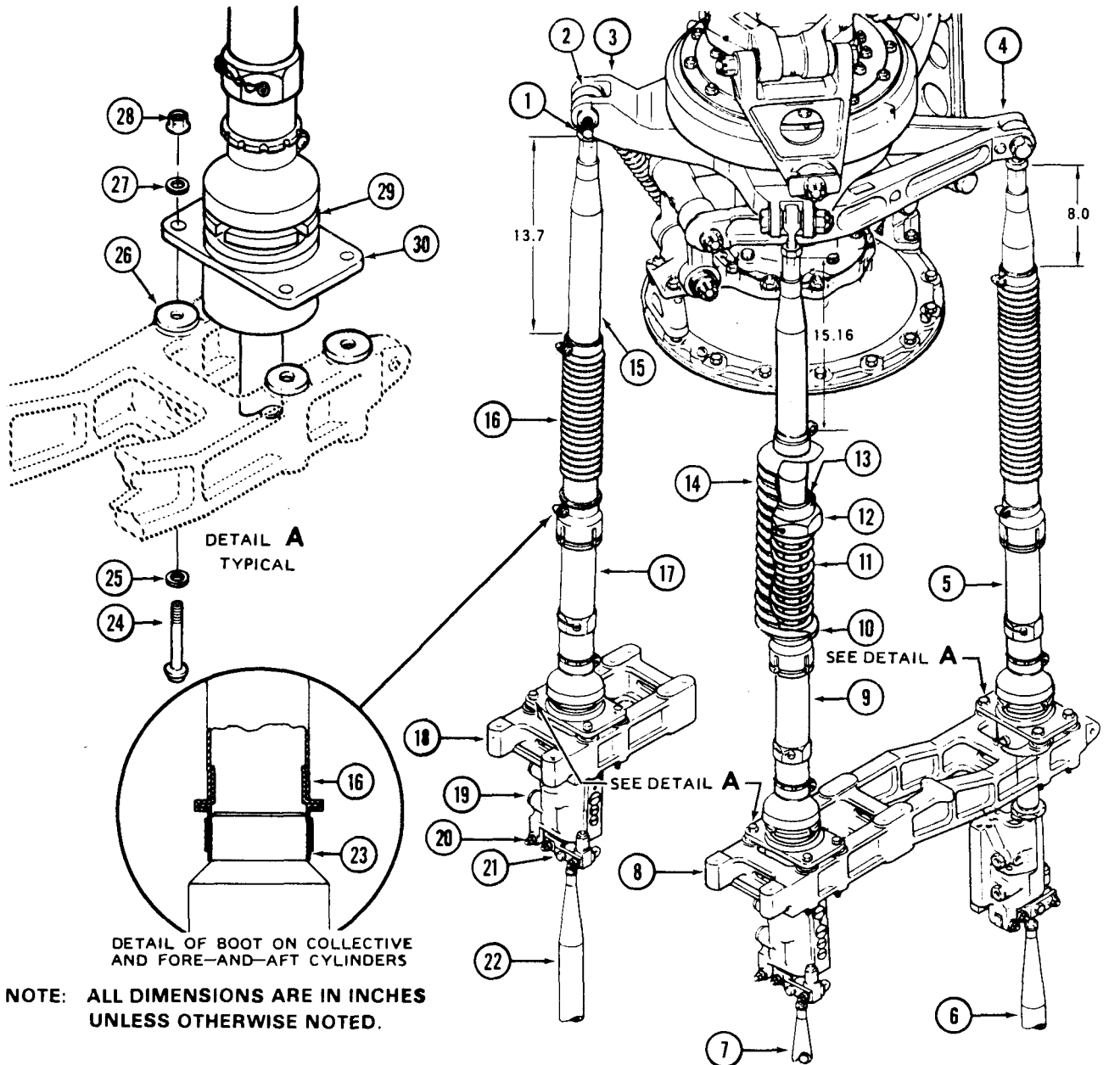

- |                                  |                                    |  |
|----------------------------------|------------------------------------|--|
| 1. Nut and lock                  | 11. Spring                         | 21. Control valve lever                |
| 2. Rod end bearing               | 12. Spring retaining nut           | 22. Control tube (fore and aft cyclic) |
| 3. Swashplate                    | 13. Nut                            | 23. Swivel joint flange                |
| 4. Collective lever              | 14. Boot                           | 24. Bolt                               |
| 5. Cylinder (collective)         | 15. Tube                           | 25. Special steel washer               |
| 6. Control tube                  | 16. Boot                           | 26. Special steel washer (bonded)      |
| 7. Control tube (lateral cyclic) | 17. Cylinder (fore and aft cyclic) | 27. Washer                             |
| 8. Support                       | 18. Support                        | 28. Nut                                |
| 9. Cylinder (lateral cyclic)     | 19. Valve                          | 29. Bearing housing nut                |
| 10. Base                         | 20. Nut and bolt                   | 30. Bearing housing                    |

209001-8H

Figure 7-3. Dual Hydraulic Servo Cylinders Installation

(f) Remove cowling from right and left TOW pylons for access to hydraulic cylinders.

(3) Prepare hydraulic test stand unit (S2) for operation. Pressure relief valve set for **2100** psig cracking pressure; pump set to provide at least **6** gpm flow; pressure compensation set at **1475 TO 1525** psig.

(4) On each of two hydraulic modular units located above reservoirs, prepare ground test couplings by removing cap from pressure coupling and disconnecting reservoir return hose from return coupling. Connect hydraulic test stand (S2) hoses to both modules.

**WARNING**

**Verify that turret gun is unloaded.**

**CAUTION**

**Ensure main rotor tiedown is removed to minimize possible contact of main rotor hub components with each other in extreme positions during ground operation with external power.**

**NOTE**

**The following procedure must be followed whenever air is in the system. It is the only way SCAS lines can be purged.**

(5) Remove main rotor tie-down. Apply 28 Volt DC electrical auxiliary power (S12) unit to external power receptacle at left side of fuselage. On pilot console, set electrical control to INV main (to provide AC PWR). Set switches to activate both hydraulic systems. On SCAS control panel switch, PWR to on. After Go/No Go lights go out, engage pitch, roll and yaw the channels on (up).

(6) Operate hydraulic test stand (S2), applying pressure (**1475 TO 1525** psig) to hydraulic systems for at least 15 minutes. During this time, perform the following:

(a) Observe all parts of systems for evidence of leakage, taking corrective action as necessary. See table 7-1 for maximum acceptable leakage.

(b) Slowly cycle all controls to limits of stroke, observing movement of hydraulic power cylinders. Check that all moving parts have clearance so that there is no fouling or binding. Give particular attention to

flexible connections, to make sure hoses are not pinched and that vibration does not tend to loosen fittings.

(c) Work out air from systems by actuating cyclic stick, collective stick, and tail rotor control pedals through at least ten full strokes. Some chatter in tail rotor controls is normal with hydraulic test stand (S2). If air is eliminated satisfactorily, proceed to step e. If air is not eliminated, accomplish step (d).

(d) When air is not removed by accomplishing procedures in step (c), perform the following:

**1.** Disconnect collective cylinder (5, figure 7-3) from collective lever (4).

**2.** Disconnect fore and aft cyclic cylinder (17) from swashplate (3).

**3.** Disconnect lateral cyclic cylinder (9) from swashplate (3).

**4.** Disconnect control tube (22) from bellcrank at lower end.

**5.** Disconnect control tube (7) from bellcrank at lower end.

**6.** Disconnect control tube (6) from bellcrank at lower end.

**CAUTION**

**Ensure that upper ends of cylinders (5,17 and 19) will not strike any object when moved through full throw during accomplishment of following steps.**

**7.** Check hydraulic test stand (S2) to ensure it is operating as described in step (6).

**8.** Pushup on fore and aft cyclic control tube (22) and hold until cylinder (17) moves through full throw. Pull down on tube (22) until cylinder (17) moves through full throw. Repeat through ten full strokes.

**9.** Move cylinder (5) and cylinder (9) through ten full strokes by same procedure outlined in step 8.

**10.** Connect control tube (22) to bellcrank at lower end.

**11.** Connect control tube (7) to bellcrank at lower end.

**12.** Connect control tube (6) to bellcrank at .lower end

**13.** Connect collective cylinder (5) to collective lever (4).

**14.** Connect fore and aft cyclic cylinder (17) to swashplate (3).

**15.** Connect lateral cyclic cylinder (9) to swashplate (3).

**(e)** Reduce pressure in both systems to 0 psig.

**(7)** Check operation of caution panel circuits as follows:

**(a)** Energize electrical system.

**(b)** Close CAUTION LTS circuit breakers.

**(c)** With test unit pressure reduced to 0 psig, cycle controls to lose residual pressure. Pilot NO. 1 HYDR PRESS, gunner HYDR PRESS #1, Pilot NO. 2 HYDR PRESS, and gunner HYDR PRESS #2 caution panel worded segments should be illuminated.

**(d)** With external hydraulic power applied, slowly increase test unit pressure. Pilot No. 1 HYDR PRESS, gunner HYDR PRESS #1, Pilot NO. 2 HYDR PRESS and gunner HYDR PRESS #2 caution panel worded segments should extinguish at **700 TO 900** psig.

**Table 7-1. Maximum Allowable Leakage for Hydraulic System**

Definitions:

D	Dynamic Seal leakage
S	Static Seal Leakage
S — D	Static leakage through dynamic seal
Drop	20 drops equal approximately one cubic centimeter

COMPONENT	FUNCTION	TYPE	LEAKAGE RATE
SERVO ACTUATORS	Tandem piston	D	2 drops/20 cycles
	(Weep hole or Intersystem vent)	S-D	4 drops/15 min.
	Rod Seal	D	1 drop/20 full stroke cycles
	Rod Seal	S-D	1 drop/20 min.
	End cap	S	1 drop/20 cycles or 2 drops/day
	Valve input	D	1 drop/5 cycles
	Valve input	S-D	1 drop/5 min.

Table 7-1. Maximum Allowable Leakage for Hydraulic System (Cont)

**Definitions:**

D	Dynamic Seal leakage
S	Static Seal Leakage
S – D	Static leakage through dynamic seal
Drop	20 drops equal approximately one cubic centimeter

COMPONENT	FUNCTION	TYPE	LEAKAGE RATE
	Servo ram (Transducer)	D	1 drop/5 cycles
	Pressure switch	S - D	1 drop/5 min.
	Valve body (Weep holes)	S - D	1 drop/5 min.
PUMPS	Output shaft	D	8 drops/rein.
	Output shaft	S - D	1 drop/rein.
	Housing (mating surfaces)	S	2 drops/day
VALVES	Body (weep hole)	S	1 drop/5 cycles or 2 drops/day
	Manual stem	D	1 drop/20 cycles
	Manual stem	S - D	1 drop/15 min.
FITTINGS	Flared or flareless	S	None
	Compression seals	S	1 drop/30 min. - lower rate if fitting is readily accessible

**Table 7-1. Maximum Allowable Leakage for Hydraulic System (Cont)****NOTES:**

1. Components in a static condition, as in a parked helicopter, are allowed a maximum leakage of two drops per seal or packing per day.
2. When the fluid escaping is of an insignificant quantity and will have no detrimental effect on helicopter operation, and when correction of this slight leakage does not warrant the maintenance time involved, the leakage is then termed "allowable".
3. If fluid leakage is such that the hydraulic reservoir may be depleted or dangerously lowered during normal operation, a fire hazard created, or the airworthiness of the helicopter otherwise compromised, the leakage is termed "excessive". Under certain circumstances, it may be possible to have enough components with allowable leakages such that their combined leakage will come under the classification of "excessive".
4. Leakage checks should not be immediately performed on helicopter hydraulic systems and components that have remained in a static unpressurized condition for an appreciable period of time. The systems should be activated first and the components operated a number of times, after which any hydraulic fluid should be wiped off before marking leakage checks.
5. Where fluid dropping from a component may be directly observed, do not wipe surfaces but pressurize and cycle the component until a drop falls free. Continue operating the component until another drop falls and compare results with leakage criteria.
6. For tests requiring long period of time, and where fluid can drop, wipe the surface clean and dry but do not use a solvent. Check for leakage after the system has operated or has been idle the required period of time.
7. Within one hour after helicopter shutdown, approximately 1 cubic inch of hydraulic fluid (volume of 204-076-012-5 accumulator) will be added to system 2 reservoir. On start up, approximately 1 cubic inch of hydraulic fluid (volume of 204-076-012-5 accumulator) will be removed from system 1 reservoir.

(e) Slowly reduce pressure. Pilot NO. 1 HYDR PRESS, gunner HYDR PRESS #1, pilot NO. 2 HYDR PRESS, and gunner HYDR PRESS #2 caution panel worded segments should illuminate at **600 TO 400** psig.

(8) Check operation of single systems as follows:

(a) Close HYDR CONT and CAUTION LTS circuit breakers.

(b) Apply external hydraulic test stand (S2) pressure to System No. 1 and System No. 2 test connectors.

(c) Energize electrical system.

(d) While operating hydraulic test stand (S2) at **1475 TO 1525** psig pressure, place HYD TEST switch (located on console) to SYS 1. Pilot NO. 2 HYDR PRESS and gunner HYDR PRESS #2 caution panel worded segments should illuminate. Pilot NO. 1 HYDR PRESS and gunner HYDR PRESS #1 caution panel worded segments should be extinguished.

(e) Operate cyclic, collective, and tail rotor controls, checking for smooth and positive response.

(f) On console, place HYD TEST switch to SYS 2. Pilot NO. 1 HYDR PRESS and gunner HYDR PRESS #1 caution panel worded segments should be illuminated. Pilot NO. 2 HYDR PRESS and gunner HYDR PRESS #2 caution panel worded segments should be extinguished. Operate cyclic and collective controls, checking for smooth and positive response.

**NOTE**

**System No. 2 does not provide boost power for tail rotor controls.**

(g) Operate tail rotor controls. Tail rotor controls will lack hydraulic power and should require more force than in normal operation.

(h) Release HYD TEST switch.

**NOTE**

**Continued operation of the cyclic actuator on System No. 1 (with System No. 2 unpressurized), could result in the hydraulic fluid being evacuated from the**

**System No. 2 cylinders. This fluid will be displaced to the System No. 2 reservoir which could overflow. Refer to table 7-3, step 13.**

(i) Decrease hydraulic test stand (S2) pressure to 0 psig.

(j) Shut down and disconnect electrical auxiliary power unit (S12) from helicopter.

(9) Check emergency hydraulic system as follows:

(a) Check emergency hydraulic system reservoir, located in right side of fuselage, underwing for proper fluid level.

(b) Using electrical auxiliary power unit (S12), engage EMERG HYDR PUMP circuit breaker.

(c) Position pilot or gunner EMER HYDR pump switch to boresight. Pilot and gunner green EMER HYD PUMP ON caution panel worded segments should illuminate.

(d) Check that collective cylinder is powered.

(e) Engage LCHR Boresight switch and check that the wing pylon actuators are powered.

(f) Place TOW ACQ/TRK/STOW switch to STOW position.

(g) Place MASTER ARM switch to ARM position.

(h) Position TURRET SELECT switch to BOTH and check that the nose turret is powered.

(i) Turn all switches to the OFF position and check that the collective actuator is not powered. Pilot and gunner green EMER HYDR PUMP ON caution panel worded segments should extinguish.

**NOTE**

**Refer to table 7-2 for emergency hydraulic system operational switching sequence.**

(j) Position pilot or gunner EMER HYDR PUMP switch to EMER. Pilot and gunner green EMER HYDR PUMP ON caution panel worded segments should illuminate. The collective actuator should be



**Table 7-2. P Emergency Hydraulic System Operational Switching Sequence**

Pilot and Gunner EMER HYDR PUMP Switch Positions	Pilot NO. 2 HYDR PRESS and Gunner HYDR PRESS #2 Caution Panel Worded Segments	Nose Turret Solenoid Valve Press	Wing Pylon Solenoid Valve Press	Emergency System Solenoid Valve Return	Emergency System Solenoid Valve Press	Emergency System Solenoid Pump	Pilot and Gunner green EMER HYDR PUMP ON Caution Panel Worded Segments
Switch in OFF Position with System No. 2 Operative	Off	On*	On*	Off	Off	Off	Off
Switch in OFF Position with System No. 2 Non-Operative	On	Off	Off	Off	Off	Off	Off
Switch in EMER Position with System No. 2 Operative	Off	On*	On*	Off	Off	Off	Off
Switch in EMER Position with System No. 2 Non-Operative	On	Off	Off	On	On	On	On
Switch in BORESIGHT Position with System No. 2 Non-Operative	On	On*	On*	On	On	On	On

**LEGEND**

On = Solenoid Valve Energized

\*On = Solenoid Valve Energized if Selected

NOTE: Hydraulic System No. 1 has no interconnect with electric-hydraulic emergency system.

powered. The turret and wing pylons should not be powered.

(k) Remove filter bowls, drain fluid and check filters for contamination and replace filter if required. Torque filter bowls **100 TO 140** inch-pounds and secure with lockwire (CI 37).

(l) Apply **1000** psig to both systems and bleed air from the systems by cycling all controls through full travel a minimum of **ten** cycles.

(m) Reduce pressure in both systems to 0 psig. Shut down hydraulic test stand (S2).

(10) Test hydraulic relief valves as follows:

(a) Disconnect System No. 2 from test unit.

(b) Slowly increase System No. 1 pressure until relief valve (located on module unit) opens. Check that relief valve opens between **1626 and 2149** psig.

(c) Reconnect System No. 2 and disconnect System No. 1 from the hydraulic test stand (S2).

(d) Repeat test procedures outlined in preceding sub-step (b) for System No. 2.

(e) Reduce pressure in both System No. 1 and No. 2 to **0** psig. Shut down hydraulic test stand (S2).

(11) Using hydraulic fluid dispenser (S1), fill reservoirs with clean hydraulic fluid (C61 or C62).

(12) Perform operational checks of armament hydraulic system in accordance with applicable instructions outlined in the following step e and paragraph 9-500.

(13) Check filter bypass indicators on each hydraulic modular unit. Replace filters as required. After replacing any filters, operate hydraulic test stand (S2) to check for leaks (table 7-1) and replenish fluid in system.

**NOTE**

**Before shut-down of operation on hydraulic test stand, (S2) center cyclic and place collective stick full down.**

(14) On pilot's SCAS control panel, switch power to OFF. Set INV/OFF/STBY to OFF. Disconnect

DC power from helicopter. Shutdown hydraulic test unit and disconnect hoses from couplings. Connect hoses from reservoirs to return test coupling on modules.

(15) Install fuselage panels removed for access. Close cowling and compartment doors.

**e. Operational Check of Hydraulic Systems Utilizing Helicopter Power.**

Perform ground runup operational check of hydraulic Systems No. 1 and No. 2 and emergency hydraulic system as follows:

**(1) Pretest Procedure.**

(a) Check hydraulic reservoir for proper fluid level. If required, using hydraulic fluid dispenser, (S1) fill reservoir with hydraulic fluid (paragraph 7-6) (C61 or C62).

(b) Check all ground test connections for replacement of dust caps.

(c) Connect a **0 TO 3000** psig calibrated gage (S13) to each system at the pressure ground test fittings.

(2) **Test.** Utilizing helicopter power (TM 55-1526-236-10), perform the following:

(a) With the cyclic, collective, and directional controls stationary, run-up helicopter power and main rotor is turning at **88 TO 98** percent.

(b) Check pressure in both hydraulic Systems No. 1 and No. 2. Pressure should be **1475 TO 1525** psig.

(c) Shut down engine. (TM 55-1520-236-10).

**NOTE**

**See note 7, table 7-1.**

(d) Remove hydraulic pressure gage (S13).

**NOTE**

**Refer to note 7, table 7-1.**

(3) **Wing Pylons and Gun Turret.** Functional check wing pylon actuators and gun turret in

accordance with procedures outlined in T M 55-1520-236-10.

**(4) Operational Check of Emergency Hydraulic System.** Perform operational check of emergency hydraulic system as follows:

(a) Run up helicopter. (TM 55-1 520-236-10).

(b) With the engine running at flight IDLE, position HYD TEST switch to SYS 1. Pilot No. 2 HYDR PRESS and gunner HYDR PRESS #2 caution panel worded segments should illuminate. Position pilot or gunner EMER HYDR PUMP switch to EMER. Pilot and gunner green EMER HYDR PUMP caution panel worded segments should illuminate.

(c) Position pilot and gunner EMER HYDR PUMP switches to OFF.

(d) Release HYD TEST switch.

(e) Shut down engine (TM 55-1 520-236-10).

**NOTE**

Refer to note 7, table 7-1.

**7 - 4 . P L U S H I N G - H Y D R A U L I C SYSTEM.**

Prior to flushing the hydraulic system, functionally check the hydraulic test stand (S2) to ensure that it is operating properly. Install new hydraulic filter elements in the test stand for maximum fluid filtration. Using hydraulic fluid dispenser (S1) fill the hydraulic reservoir to capacity with clean, hydraulic fluid (C61 or C62). Inspect pressure and return hoses on hydraulic test stand (S2) for cleanliness. Clean the hoses if required. Clean and flush the hydraulic system as follows:

**NOTE**

Systems must be flushed individually at 1000 psi. Flushing is required only if system is rebuilt due to major damage or if fluid has become contaminated.

**Premaintenance Requirements for Flushing Hydraulic System**

Condition	Requirements
Model	A H - 1 <b>SP</b>
Part No. or Serial No.	All
Special Tools	None
Test Equipment	None
Support Equipment	(S1) (S2) (S10)(S12)
Minimum Personnel Required	Two
Consumable Materials	(C62) (C112) (C137) (C61)
Special Environmental Conditions	Dust free well ventilated area

**a. Test Equipment Requirements.**

Test equipment shall consists of a thoroughly clean (S2) hydraulic test stand serviced with hydraulic fluid (C61 or C62) and as follows:

(1) Be capable of producing pressures of **2300** psig with minimum flow rate of **6** gpm.

(2) Include a calibrated pressure gage with a minimum capacity of **2500** psig.

(3) Include a 10-micron absolute metal filter on the pressure line and a 10-micron absolute metal filter on the return line.

(4) Include provisions in the pressure and return lines for connecting both System No. 1 and System No. 2 for simultaneous operation.

b. Prepare and test hydraulic systems as follows:

**NOTE**

Immediately after disconnecting hoses. cap cylinder ports to prevent contamination of system.

(1) Disconnect hoses from cyclic and collective cylinders. Connect hose ends together with MS21902D4 and MS21902D6 unions.

(2) Disconnect hoses from tail rotor control cylinder and (SCAS) servo actuators in the lateral, fore and aft, and directional control systems. Connect hose ends together with MS21916D5-4 reducers.

(3) Disconnect hoses from left and right wing pylon servo actuators. Connect hose ends together with MS21902D6 unions.

(4) Deleted.



**Use extreme caution in handling filter element to prevent contamination damage.**

(5) Remove filters and discard elements from four filter element bowls of hydraulic modular units (paragraph 7-46). Do not remove packings. Immediately after removing filter elements, reinstall bowls. Torque bowls **100 TO 140** inch-pounds.



Hydraulic Systems No. 1, No. 2 and emergency system cannot be flushed at the same time.

(6) Connect hydraulic test stand (S2) to System No. 1 through ground test fittings (12, figure 7-1) (located on service deck on right side of helicopter inside access door).

(7) Make a thorough visual inspection of complete hydraulic system to ensure that all components and lines are securely attached and appear, capable of satisfactory operation before continuing flushing.

(8) When performing steps (9) thru (11), observe all system lines and components for external leakage. Take appropriate action to correct any leakage before proceeding.

(9) Connect external 28 Vdc electrical auxiliary power unit (S12) to helicopter.

(10) Energize HYDR CONT circuit breaker.

(11) Turn hydraulic test stand (S2) ON. Adjust hydraulic test stand (S2) to sufficient pressure to maintain **6** gpm minimum flow rate. Energize the directional SCAS system solenoid valve. Flush system for **5** minutes. Reduce pressure and shut hydraulic test stand (S2) OFF. De-energize the directional SCAS system solenoid valve. Reconnect all System 1 hoses except those on the two cyclic actuators.

#### NOTE

**With all actuators bypassed, the lockout valve isolates the cyclic actuators (650 to 850 psi is required to open the lockout valve),**

(12) Turn hydraulic test stand (S2) ON; adjust outlet pressure to **800 TO 1000** psig and flush for a minimum of 3 minutes. Reduce pressure and shut hydraulic test stand (S2) off. Reconnect System 1 hoses on the cyclic actuators.

(13) Disconnect hydraulic test stand (S2) from System No. 1 and connect to System No. 2 through ground test fitting in module assembly.

(14) Turn hydraulic test stand (S2) and electrical auxiliary power unit (S12) ON. Adjust hydraulic test stand (S2) pressure to maintain a flow rate of **6** gpm. Energize the pitch and roll SCAS system solenoid valves. Flush system for **5** minutes. Reduce pressure and shutoff hydraulic test stand (S2). De-energize pitch and roll SCAS system solenoid valve. Reconnect pitch, roll and cyclic actuator hoses.

(15) Perform flushing operation as follows:

(a) Energize the following circuit breakers:

HYDR CONT  
TURRET CONT  
WPN CONT  
WPN FIRE

(b) Turn main inverter ON. MASTER ARM switch to ARM position. TOW system TCP MODE SELECT switch ON (STBY/TOW or any of the four ARMED MODE positions. Turn LAUNCHER ACTIVATE SWITCH in the ammo bay to either L/H or R/H. This will open the hydraulic solenoid valve for the articulated pylons.

(c) Turn electrical auxiliary power unit (S12) ON.

(d) Turn hydraulic test stand (S2) ON. Increase pressure to **800 TO 1000** psig and flush for a minimum of **5** minutes.

(e) Turn hydraulic test stand (S2) OFF.

(f) Turn electrical auxiliary power unit (S12) OFF.

(g) Move MASTER ARM switch to OFF position.



**Ensure that fluid in hydraulic test stand is the same type fluid as in the helicopter.**

(16) Filling and flushing of emergency hydraulic system. Fill and flush emergency hydraulic system as follows:

(a) Drain fluid from reservoir (2, figure 7-2) (paragraph 7-9).

(b) Remove filler cap from the reservoir (figure 7-5) mounted on bulkhead at station 213.94 in the hydraulic compartment under right wing. Using hydraulic fluid dispenser (S1), fill reservoir with clean hydraulic fluid (C61 or C62). Refer to paragraph 7-6 for servicing of reservoir.



**To prevent pump damage (running dry), engage pilot or gunner EMER HYDR PUMP switch to BORESIGHT position with a momentary ON-OFF action until the pump is filled.**

(c) With electrical auxiliary power unit (S16) connected, engage EMER HYDR PUMP circuit breaker. Energize electrical auxiliary power unit (S12) and move pilot or gunner EMER HYDR PUMP switch to BORESIGHT position. Flush system for **five** minutes.

(d) Continue filling reservoir until all air is purged and reservoir is full.

(e) Position pilot and gunner EMER HYDR PUMP switches from BORESIGHT to OFF position.

(f) Turn electrical auxiliary power unit (S12) OFF.

(g) De-energize all circuit breakers.

(17) Provide a small container to catch oil when disconnecting hoses after a flushing operation. Remove dust caps from dual hydraulic cylinder ports. Reconnect hoses to collective dual hydraulic cylinders, wing pylon servo actuators, and turret.

**NOTE**

**Cyclic dual hydraulic cylinder lines may have residual pressure caused by lockout valve and accumulator assembly.**

(18) Replace filter elements previously removed. Torque filter bowls **100 TO 140** inch-pounds and secure with lockwire (CI37).

(19) Using hydraulic fluid dispenser (S1), fill System No. 1 and No. 2 reservoirs with clean hydraulic fluid (C61 or C62) until all air is purged and reservoirs are full. Refer to paragraph 7-6 for servicing of reservoirs.

(20) Bleed hydraulic system in accordance with procedures outlined in paragraph 7-3.

(21) Disconnect hydraulic test stand (S2) and electrical auxiliary power unit (S12) from helicopter.

7 - 5 . **P** T R O U B L E S H O O T I N G -  
HYDRAULIC SYSTEM.

NOTE

The following list of conditions, tests or inspections and corrective actions is intended to aid in hydraulic system troubleshooting. This guide should be used with other sources of information such as; (1) Hydraulic System Schematic Illustration; (2) Electrical diagrams; and (3) Operational Ground Test and other detailed procedures in this section

Ensure that all normal operational checks have been performed prior to using the following table 7-3. Any malfunction not listed requires assistance of next higher maintenance level.

Table 7-3. **P** r o u b l e s h o o t i n g o f H y d r a u l i c S y s t e m

---

CONDITION

TEST OR INSPECTION

**CORRECTIVE ACTION**

1. Pilot No. 1 HYDR PRESS, pilot NO. 2 HYDR PRESS, gunner HYDR PRESS #1, and/or gunner HYDR PRESS #2, caution panel worded segments reported being illuminated during normal operation.

STEP 1. Loss of fluid and pressure by leakage.

**Locate and repair leaks; replace faulty lines, hoses, seals, or other parts. Service system as required (paragraph 7-6).**

STEP 2. Total loss of fluid in system.

**Replace pump (paragraphs 7-25 and 7-29).**

STEP 3. Other malfunction in system.

**Perform operational check with hydraulic test stand (S2) (paragraph 7-3).**

STEP 4. If pilot NO. 1 HYDR PRESS, pilot No. 2 HYDR PRESS, gunner HYDR PRESS #1, or gunner HYDR PRESS #2 caution panel worded segments do not illuminate and system operates normally with hydraulic test stand (S2), trouble may be in the pump circuit or defective pump.

**Replace pump (paragraphs 7-25 and 7-29).**

STEP 5. Pump pressure line restricted or check valve reversed.

**Replace or correct installation of parts (paragraph 7-18).**

Table 7-3. **P**roblemshooting of Hydraulic System (Cont)

## CONDITION

## TEST OR INSPECTION

**CORRECTIVE ACTION**

STEP 6. System actuators operate normally on hydraulic test stand (S2), but caution segment is illuminated, caution circuit may be faulty or pressure switch faulty.

**Replace pressure switch (figure 7-4) in hydraulic modular unit (paragraph 7-39).**

STEP 7. Electric circuit malfunction.

**Check and repair electrical circuit (paragraphs 9-8 through 9-13 and paragraph 9-374).**

STEP 8. Caution panel light is illuminated and system actuators do not operate normally with hydraulic test stand (S2), trouble may be in the hydraulic modular unit or beyond the hydraulic modular unit.

STEP 9. System solenoid valve staying at OFF position or faulty HYDR TEST switch.

**Replace hydraulic modular unit (paragraphs 7-39 and 7-43). Repair electrical circuit (paragraphs 9-8 through 9-13) or replace switch (paragraphs 9-20 and 9-22).**

STEP 10. System relief valve staying open or relieving at too low pressure.

**Replace relief valve in hydraulic modular unit.**

STEP 11. Internal leakage through a unit.

**Isolate and replace defective unit.**

2. (SCAS) actuator will not unlock from it's center position.

STEP 1. Faulty wiring, switches or connections.

**Refer to chapter 11 and TM 11-1520-236-20 or TM 11-1520-236-34, Troubleshooting Stability and Control Augmentation System (SCAS).**

STEP 2. Filter clogged.

**Replace in line hydraulic filter (paragraph 7-79).**

STEP 3. Restricted flow in pump suction line.

**Inspect reservoir and lines; replace faulty parts (paragraphs 7-7 and 7-20).**

3. Pilot NO. 1 HYDR PRESS, Pilot NO. 2 HYDR PRESS, gunner HYDR PRESS #1, or gunner HYDR PRESS #2 caution panel worded segments fail to illuminate when HYD TEST switch is at other system position.

STEP 1. Caution panel lamp or light indicating panel (caution panel) failed.

**Replace lamp (paragraph 9-282) or light indicating panel (caution panel) (paragraphs 9-281 and 9-283).**

Table 7-3. **P** Troubleshooting of Hydraulic System (Cont)

---

CONDITION

TEST OR INSPECTION

**CORRECTIVE ACTION**

STEP 2. Pressure switch in hydraulic modular unit or wiring faulty.

**Replace pressure switch (figure 7-4). Repair electrical circuit (paragraphs 9-8 through 9-13 and paragraph 9-284).**

STEP 3. System solenoid or electrical circuit faulty.

**Repair electrical circuit (paragraph 9-284) or replace hydraulic modular unit (paragraphs 7-39 and 7-43).**

STEP 4. Faulty HYD TEST switch.

**Replace switch.**

4. Filter element differential pressure indicators tripped.

STEP 1. Fluid temperature below 20 degrees F (-7 degrees C).

**Operate until fluid temperature is normal, then reset indicators by pushing buttons in. If not again tripped, no further action needed (figure 7-4) (paragraph 7-45).**

STEP 2. Indicators tripped by unusual vibration or hydraulic modular unit being struck.

**Check hydraulic modular unit for damage, reset indicators. If not again tripped, no further action needed (figure 7-4).**

STEP 3. Clogged filter elements.

**Inspect and replace filter elements (paragraphs 7-46 and 7-50). Reset indicators (paragraph 7-45).**

STEP 4. Defective indicator assembly.

**Replace hydraulic modular unit (paragraphs 7-39 and 7-43).**

5. Servo cylinders chatter when controls are moved. (Some chatter in tail rotor control cylinder is normal when using hydraulic test stand (S2).

STEP 1. Air in system.

**Cycle controls at least ten full strokes at normal operating pressure to work out air (paragraph 7-3).**

STEP 2. Loose mounting bearing (9, figure 7-12) on dual hydraulic cylinder. Replace dual hydraulic cylinder assembly (paragraphs 7-60 and 7-66).



Table 7-3. **P** Troubleshooting of Hydraulic System (Cont)

## CONDITION

## TEST OR INSPECTION

**CORRECTIVE ACTION**

STEP 3. Any internal looseness in dual hydraulic cylinder assembly.

**Replace dual hydraulic cylinder assembly (paragraphs 7-60 and 7-66).**

6. Controls do not operate smoothly,

STEP 1. Servo valve on dual hydraulic cylinder is binding (requires more than 12 oz. force to operate valve).

**Check to ensure all bolts at servo head linkage are free to rotate by finger pressure. Replace dual hydraulic cylinder assembly (paragraph 7-60 and 7-66).**

STEP 2. Incorrect bolts inserted.

**Check the valve linkage bolts. Install correct bolts.**

7. Excessive feedback in operation of controls.

STEP 1. Air in servo cylinders.

**Cycle controls at least ten times to work out air (paragraph 7-3).**

STEP 2. Loose or worn bearing housing mounting studs.

**Tighten or replace mounting studs.**

8. Hydraulic power inadequate or lacking at couplings for armament turret or TMS launchers (other indications normal).

STEP 1. Faulty circuit to armament couplings, or System No. 2 pressure is marginally low.

**Check operation with hydraulic test stand (S2) (paragraph 7-3).**

STEP 2. No improvement when using hydraulic test stand (S2) for normal system pressure, or armament, or TMS solenoid valve inoperative.

**Replace solenoid valve (paragraphs 7-117 and 7-1 25) or repair electrical circuit (paragraphs 9-8 through 9-13 and paragraph 9-374),**

STEP 3. Restriction in test connectors (12, figure 7-1) or lines.

**Replace defective parts (paragraphs 7-18 and 7-22).**

STEP 4. Operation becomes normal on hydraulic test stand (S2), or System No. 2 pump or lines defective.

**Replace faulty lines (paragraphs 7-18 and 7-22) or replace pump (paragraphs 7-25 and 7-29).**

**Table 7-3P Troubleshooting of Hydraulic System (Cont)**

CONDITION

TEST OR INSPECTION

**CORRECTIVE ACTION**

9. System No. 2 reservoir overflows.

**NOTE**

**Within one hour after helicopter shut down approximately 1 cubic inch of hydraulic fluid from accumulator, P/N: 204-076 -012-5 will be added to system 2. On start up approximately 1 cubic inch of hydraulic fluid will be removed from system 1 reservoir to fill accumulator P/N 204-076-012-5.**

STEP 1. Repeated cyclic inputs with hydraulic system test switch in System No. 1 position.

**Release hydraulic system test switch. Actuate cyclic stick, approximately ten full cycles, to remove air from actuators (paragraph 7-3), Replenish fluid in reservoir (paragraph 7-6).**

10. Either left or right TOW pylons inoperative or sluggish. (System No. 2 operation otherwise normal.)

STEP 1. Electrical wiring faulty.

**Repair electrical circuit (paragraphs 9-8 through 9-13 and paragraph 9-374).**

STEP 2. Faulty electrical circuit to actuator.

**Repair electrical circuit (paragraphs 9-8 through 9-13 and paragraph 9-374).**

STEP 3. TOW solenoid valve stuck closed.

**Replace solenoid valve (paragraphs 7-117 and 7-125).**

STEP 4. Check SECU and TOW system.

11. Only one TOW pylon inoperative or operates sluggish. (Other TOW pylon operates normal.)

STEP 1. Restricted hydraulic fluid in circuit of affected wing pylon servo actuator.

**Inspect hoses and tubes; replace faulty parts (paragraph 7-16).**

STEP 2. Faulty electrical circuit to affected wing pylon servo actuator.

**Repair electrical circuit (paragraphs 9-8 through 9-13 and paragraph 9-374).**

STEP 3. Defective armament wing pylon servo actuator.

**Replace armament wing pylon servo actuator (paragraphs 7-128 and 7-142).**

STEP 4. Check SECU and TOW system.

Table 7-3. **P** Troubleshooting of Hydraulic System (Cont)

## CONDITION

## TEST OR INSPECTION

**CORRECTIVE ACTION**

12 Pylons do not remain in stowed position with TOW system OFF and hydraulic system operational.

STEP 1. Fault in electrical wiring.

**Repair electrical circuit (paragraphs 9-8 through 9-13 and paragraph 9-374).**

STEP 2. Faulty electrical circuit to pylon servo actuators.

**Repair electrical circuit (paragraphs 9-8 through 9-13 and paragraph 9-374).**

STEP 3. TOW solenoid valve stuck open.

**Replace solenoid valve (paragraphs 7-117 and 7-125).**

STEP 4. Check valve installed backwards or stuck open.

**Reverse or replace check valve (figure FO-1).**

STEP 5. Check SECU.

13 With hydraulic test stand (S2) and electrical power unit (S12) connected to helicopter and operating, and with pilot and/or gunner EMER HYDR PUMP switch in BORESIGHT or EMER position, pilot and/or gunner green EMER HYDR PUMP caution panel worded segments do not illuminate.

STEP 1. If collective controls are powered, check for a faulty panel lamp or light indicating panel (caution panel).

**Replace panel lamp (paragraph 2-282) or replace light indicating panel (caution panel) (paragraphs 9-281 and 9-283).**

STEP 2. If collective controls are powered, check for faulty electrical wiring.

**Repair wiring (paragraphs 9-8 through 9-13 and paragraph 9-284).**

STEP 3. If collective controls are powered, check for faulty pressure switch.

**Replace pressure switch in hydraulic modular unit (figure 7-4).**

STEP 4. If collective controls are unpowered and emergency electric motor driven pump package failed, check for faulty wiring or switch.

**Repair wiring (paragraphs 9-8 through 9-13), or replace switch (paragraphs 9-20 and 9-22), or replace emergency electric motor driven pump package (paragraphs 7-32 and 7-36).**

Table 7-3. **P** Troubleshooting of Hydraulic System (Cont)

CONDITION

TEST OR INSPECTION

**CORRECTIVE ACTION**

14. With electrical power unit (S12) connected to helicopter and operating, and with pilot and/or gunner EMER HYDR PUMP switch in BORESIGHT or EMER position, and pilot and gunner green EMER HYDR PUMP caution panel worded segments illuminated, System No. 2 is non-operative and collective controls are unpowered.

STEP 1. Faulty electrical wiring.

**Repair wiring (paragraphs 9-8 and 9-13 and paragraph 9-374).**

STEP 2. Pressure or return solenoid valve failed.

**Replace pressure or return solenoid valve (paragraphs 7-97 and 7-107).**

15. With electrical auxiliary power unit (S12) connected to helicopter and turned ON, pilot and/or gunner EMER HYDR PUMP switch in EMER position, System No. 2 non-operative, wing pylons and/or nose turret are powered when switches are engaged.

STEP 1. Faulty electrical wiring to armament wing pylon and/or nose turret solenoid valve.

**Repair wiring (paragraphs 9-8 through 9-13 and paragraph 9-374).**

16. With electrical auxiliary power unit (S12) connected to helicopter and turned ON, pilot and/or gunner EMER HYDR PUMP switch in BORESIGHT position, System No. 2 non-operative, armament wing pylons and/or turret are not powered when switches are engaged.

STEP 1. Faulty electrical wiring to armament wing pylon and/or turret solenoid valve.

**Repair wiring (paragraphs 9-8 through 9-13 and paragraph 9-374), or replace pylon solenoid valve (paragraphs 7-117 and 7-125), or replace armament wing pylon servo actuator (paragraphs 7-128 and 7-142).**

**7-6. **P** SERVICING – HYDRAULIC SYSTEM.**

**Premaintenance Requirements for Servicing Hydraulic System**

Condition	Requirements
Model	AH-IS
Part No. or Serial No.	All
Special Tools	None
Test Equipment	None

Conditions	Requirements
Support Equipment	(S1)(S10)
Minimum Personnel Required	One
Consumable Materials	(C61) (C62) (C1 37) (C88)(C91)(C112) (C1 20) (C102) (C31)
Special Environmental Conditions	Clean/dust free area

a. Provide suitable maintenance work stand and open left and right access doors (8, figure 2-3) and right access panel (17).

b. Remove cap from System No. 1 reservoir (figure 7-4). Using hydraulic fluid dispenser (S1) and clean hydraulic fluid (C61 or C62) fill reservoir to overflow until all excess air bubbles have been expended. Service System No. 2 reservoir and emergency system reservoir (figure 7-5) in the same manner.

c. Install cap to reservoir.

d. Install right access panel (17).

e. Close left and right access doors (8).

**7-7. HYDRAULIC RESERVOIR.**

**7-8. DESCRIPTION – HYDRAULIC RESERVOIR.**

Two separate hydraulic reservoirs are located in a compartment directly aft of the pilots canopy. Both are mounted on Station 186.25 bulkhead, with System No. 1 reservoir near left side and System No. 2 reservoir near right side (figure 7-4). An additional reservoir has been added to the hydraulic system to accommodate the electrically operated hydraulic emergency system, located below and inboard of right pylon wing and is mounted on the aft bulkhead (figure 7-5). Each is a non-pressurized reservoir of 3.1 pints capacity, equipped with a filler cap and screened adapter, and overflow scupper, a screened vent, a fluid vent, a fluid level sight glass and marked ports for system connections. Hinged left and right doors (8, figure 2-3) provide access to both side of compartment, and fluid level sight glass are placed for view from the left door.

**Premaintenance Requirements for Hydraulic Reservoir**

Condition	Requirements
Model	AH-IS
Part No. or Serial No.	All
Special Tools	None
Test Equipment	None

Conditions	Requirements
Support Equipment	(S1) (S10)
Minimum Personnel Required	One
Consumable Materials	(C21) (C22) (C31) (C61) (C88) (C102) (C120) (C122) (C127) (C128)(C137)
Special Environmental Conditions	Clean/dust free area

**7-9. REMOVAL – HYDRAULIC RESERVOIR.**

**a. Systems No. 1 and No. 2.**

(1) Open right transmission cowling (11, figure 2-3) for access to hydraulic pumps. Using a suitable container to catch fluid, disconnect reservoir SUCTION hose from pump INLET fitting and allow fluid to drain from reservoir and connecting lines. Reconnect hose to pump,

(2) Open hinged door for access to reservoir compartment. Provide a suitable container and drain fluid from reservoir. Disconnect all lines and hoses from reservoir fittings. Cap or cover all open fittings and lines.

(3) Remove three bolts, with nuts and washers, to detach reservoir from bulkhead. Lift reservoir from compartment.

(4) If reservoir is being replaced, remove fittings from ports marked SUCTION, BYPASS, and DRAIN (scupper) for use in new reservoir, (figure 7-6).

**b. Emergency Hydraulic System.**

(1) Remove right access panel (19, figure 2-3).

(2) Provide a suitable container. Remove lockwire from plug (7, figure 7-6). Remove plug and drain hydraulic fluid from reservoir (5).

(3) Disconnect all lines and hoses from reservoir. Cap or cover all open fittings and lines.

(4) Remove three bolts, with nuts and washers, to detach reservoir from bulkhead. Lift reservoir from compartment.

(5) If reservoir is being replaced, remove fittings from ports marked SUCTION, BYPASS, and DRAIN (scupper) for use in new reservoir.

**7-10. DISASSEMBLY - HYDRAULIC RESERVOIR.**

Disassemble hydraulic reservoir as follows:

- a. Remove cap (1) from adapter (2, figure 7-6).
- b. Remove adapter (2) and screen (3) from reservoir.

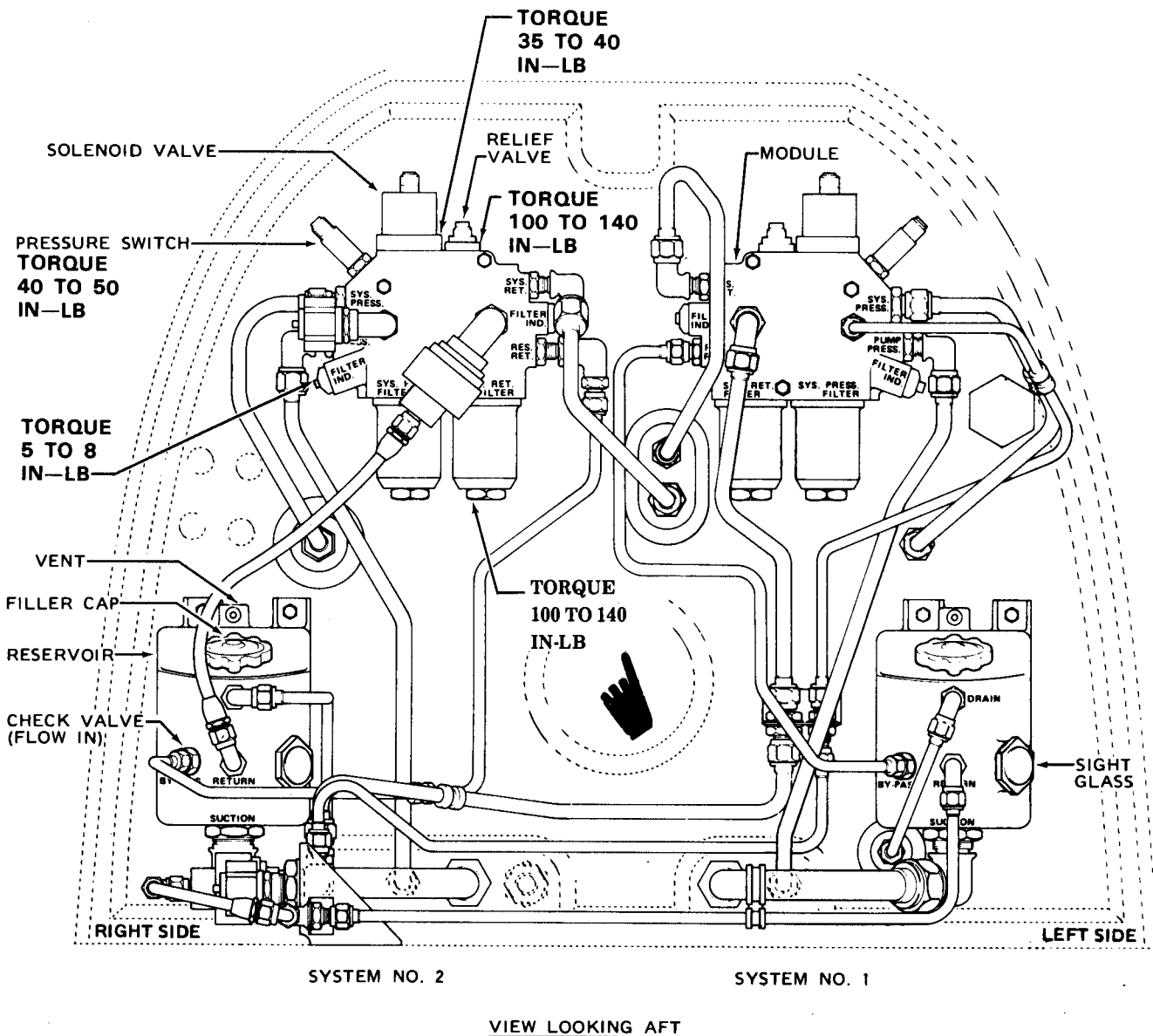

209076-27

Figure 7-4. Hydraulic Reservoirs

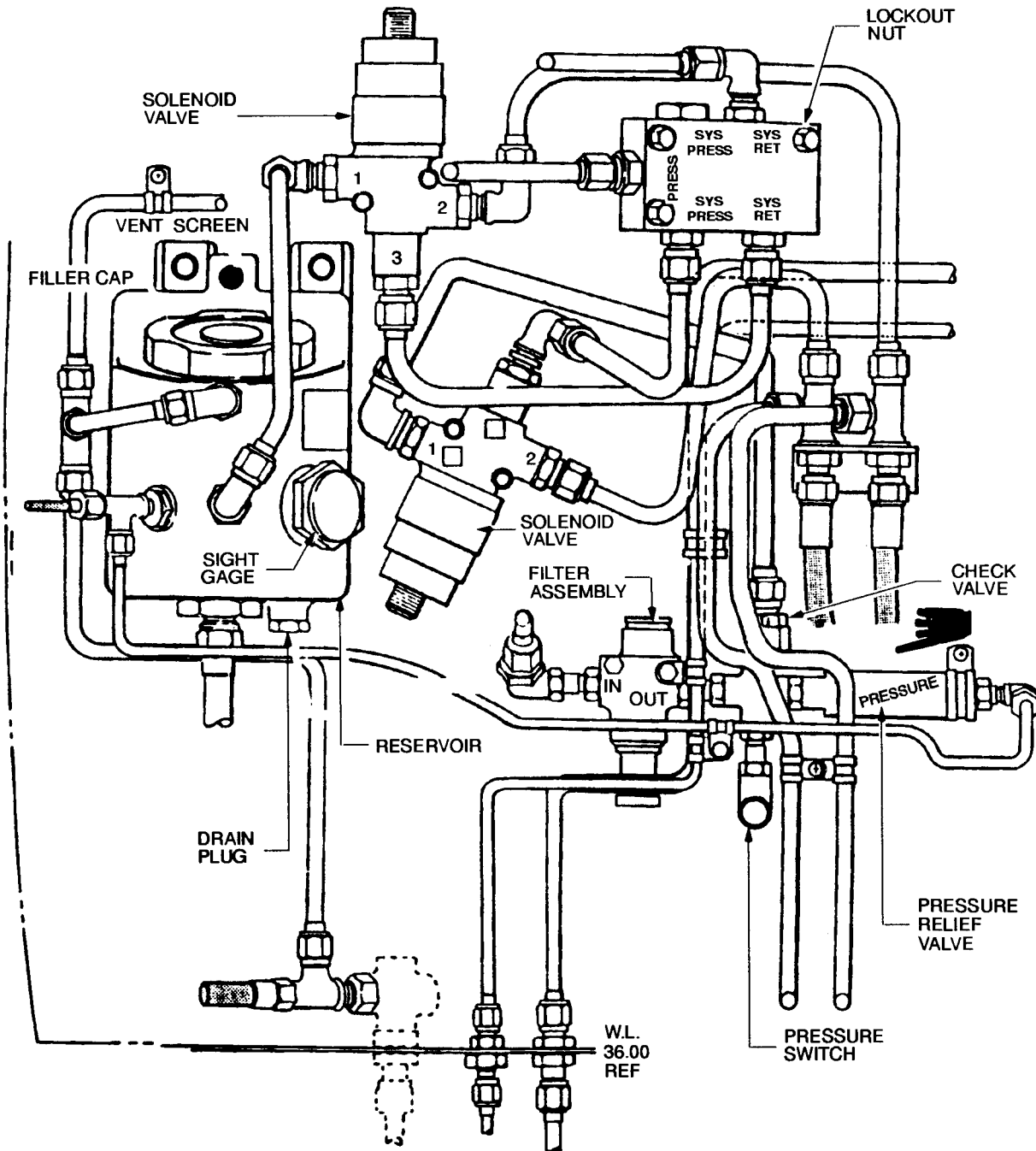

VIEW LOOKING AFT - RIGHT SIDE

Figure 7-5. **P** Hydraulic Reservoir - Emergency System (Sheet 1 of 2).

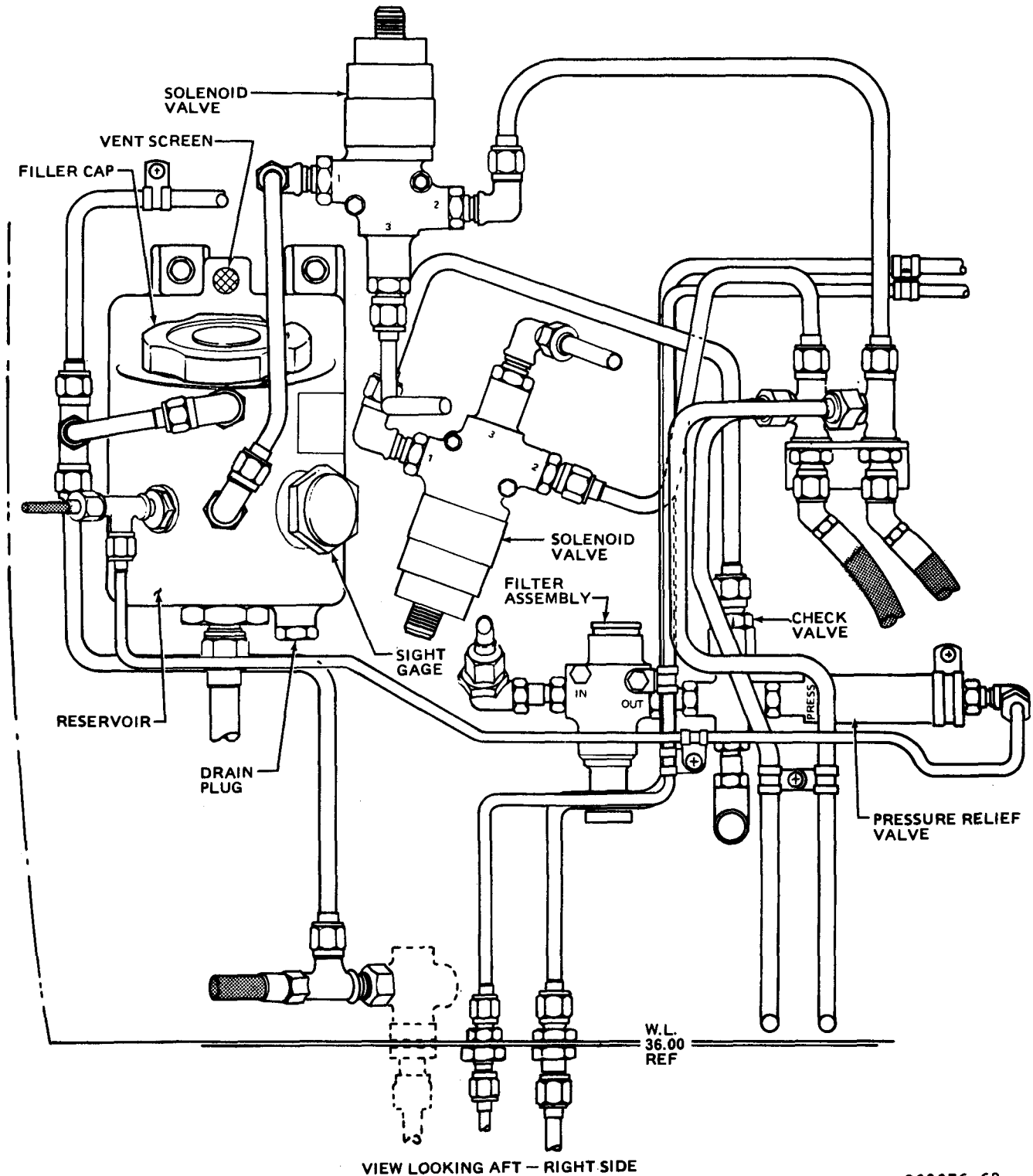

209076-62

Figure 7-5. **E M** Hydraulic Reservoir - Emergency System (Sheet 2 of 2)



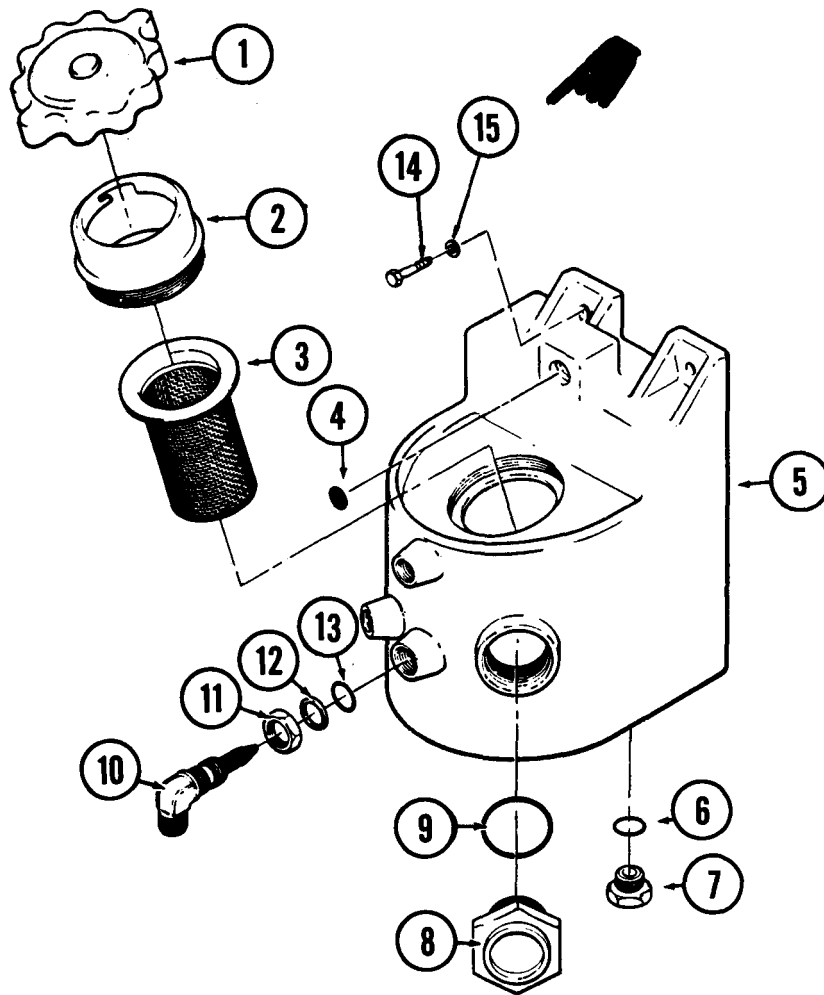

209076-49A

- |                |               |                   |
|----------------|---------------|-------------------|
| 1. Cap         | 6. Packing    | 11. Nut           |
| 2. Adapter     | 7. Plug       | 12. Ring (backup) |
| 3. Screen      | 8. Sight gage | 13. Packing       |
| 4. Vent screen | 9. Packing    | 14. Bolt          |
| 5. Reservoir   | 10. Baffle    | 15. Washer        |

Figure 7-6. Hydraulic Reservoir Assembly

c. Break torque on nut (11) and remove baffle (10). Remove packing (13), ring (12) and nut (11) from baffle (10).

d. Remove lockwire from sight gage (8). Remove sight gage from reservoir (5).

e. Remove packing (9) from sight gage (8).

f. When requirements are necessary for replacing of vent screen (4), three point staked areas must be removed (by grinding or sanding) in order to remove screen.

7-11. **P** CLEANING — HYDRAULIC RESERVOIR.

**WARNING**

Cleaning solvent is flammable and toxic. Provide adequate ventilation. Avoid prolonged breathing of solvent vapors and contact with skin or eyes. Eye protection is required when using compressed air.

a. Thoroughly wash and clean inside and outside of reservoir and fittings with solvent (C112). Drain completely and dry with filtered compressed air, with care to avoid pressurizing the reservoir.



**Ensure that fluid in hydraulic test stand is the same type fluid as in the helicopter.**

b. Flush inside of reservoir with hydraulic fluid (C61 or C62).

#### 7-12. **P**NSPECTION - HYDRAULIC RESERVOIR.

a. Visually inspect filler cap adapter and strainer screen for rust, cleanliness, damage, and corrosion and security.

b. Inspect fluid level sight gage (8, figure 7-6) for scratches, cracks, checks, internal staining, and other defects of transparency which could prevent proper sight of fluid level.

c. Inspect sight gage (8) for leaks and security.

d. Inspect vent screen (4) for cleanliness, damage, and corrosion.

e. Inspect screen (31) for damage and corrosion.

f. Inspect screen on inner end of RETURN port fitting for cleanliness and damage.

g. Inspect bosses of reservoir for damaged threads, corrosion, and damage to packing contact surfaces.

h. Inspect reservoir for security and leaks.

i. Inspect attaching tubes and hoses for damage.

j. Inspect reservoir for cracks, nicks, and scratches. No cracks are acceptable.

k. Inspect fittings for damaged threads.

#### 7-13. **P**REPAIR OR REPLACEMENT - HYDRAULIC RESERVOIR.

a. Replace parts that fail to meet inspection requirements of paragraph 7-12. Refer to paragraph 7-14 for assembly instructions.

b. Replace all packings.

c. Polish all nicks and scratches to original finish and touchup with primer (C88 or C91).

#### 7-14. **P**ASSEMBLY - HYDRAULIC RESERVOIR.

a. Ensure that all parts are thoroughly clean prior to performing the following assembly procedures (paragraph 7-11).

b. Install nut (11, figure 7-6), ring (12) and packing (13) on baffle (10). Install baffle (10) on reservoir (5).

c. Install packing (9) on sight gage (8) and install sight gage on reservoir (5). Secure sight gage to reservoir with lockwire (C137).

d. Position vent screen (4) into port of reservoir (5) and point stake (three places). Ensure security of vent screen.

e. Place screen (3) into port of reservoir (5).

f. Apply a light coat of primer (C88 or C91) to threads of adapter (2) and install adapter on reservoir (5).

g. Install cap (1) on adapter (2).

h. If reservoir is not to be immediately installed, cap or plug all fittings and port openings.

#### 7-15. **P**INSTALLATION - HYDRAULIC RESERVOIR.

##### a. Systems No. 1 and No. 2.

(1) Check reservoir assembly to ensure all fittings are properly installed. If replacing a reservoir assembly, install the following parts which are not included on spares:

(a) For SUCTION boss, assemble and install an elbow, nut, packing and ring. Position elbow to point forward and inboard when reservoir is in place.

(b) For BY-PASS boss, assemble and install ring, packing, tee fitting and nut.

(c) For scupper DRAIN boss, assemble and install an elbow, nut, packing, and ring. On System

No. 1 reservoir, elbow should point down between RETURN and BY-PASS fittings. On System No. 2 reservoir, elbow should point slightly down but above sight plug.

(2) Install dissimilar metal separation tape (C120) to three mounting pads of reservoir (5, figure 7-6).



Aluminum washers P / N NAS1197-416, only, must be installed under bolt head.

(3) Place three aluminum washers (15) on three bolts (14) and apply a light film of primer (C88 or C91) to bolt shanks. Position reservoir on threaded insert in bulkhead and install bolts.

(4) Connect lines and hose to reservoir fittings (figure 7-1).

(5) Service and test hydraulic system (paragraphs 7-3 and 7-6).

**b. Emergency Hydraulic System.**

(1) Install hydraulic reservoir (5, figure 7-6) to electric emergency system in accordance with procedural steps outlined in preceding step a.

(2) Service and test hydraulic system (paragraphs 7-3 and 7-6).

**7-16. P HOSES, TUBING, AND FITTINGS.**

**7-17. P DESCRIPTION - HOSES, TUBING, AND FITTINGS.**

Throughout No. 1, No. 2, and emergency hydraulic systems are hoses, tubing, and fittings that interconnect reservoirs, check valves, relief valves, solenoid valves, pumps, etc, and are attached to fuselage structure with clamps, spacers, screws, and nuts.

**7-18. P REMOVAL - HOSES, TUBING, AND FITTINGS.**

**NOTE**

Removal of hoses, tubing, and fittings will apply only as necessary to perform

maintenance functions to the hydraulic system (figure 7-1).

**7-19. P CLEANING - HOSES, TUBING AND FITTINGS.**



Cleaning solvent is flammable and toxic. Provide adequate ventilation. Avoid prolonged breathing of solvent vapors and contact with skin or eyes. Eye protection is required when using compressed air.

a. Wash hoses, tubing, and fittings with solvent (C112) and dry with clean filtered compressed air.

b. Clear hoses, tubing, and fittings with clean filtered compressed air.

**7-20. P INSPECTION - HOSES, TUBING, AND FITTINGS.**

a. Inspect tubing for nicks, cuts, cracks, and deformed condition (TM 55-1500-204-25/1). Minor nicks, scratches, and dents on fittings are acceptable provided they are sanded smooth with 600 grit sandpaper (C102), treated with chemical film material (C31) and touched up with primer (C88 or C91).

b. Inspect threaded parts for corrosion and mechanical damage. Damaged threads are not acceptable.

c. Inspect hoses for fraying, cuts, and deterioration. Damage more severe than superficial is not acceptable.

**7-21. P REPAIR OR REPLACEMENT - HOSES, TUBING, AND FITTINGS,**

a. Replace parts that fail to meet inspection requirements of paragraph 7-20.

b. Refer to appendix D and to TM 55-1500-204-25/1 for instructions to fabricate tubing and hoses.

**7.22. P INSTALLATION-HOSES, TUBING, AND FITTINGS.**

a. Prior to and after installation of part, observe the following:

- (1) Part is clear of obstructions and clean.
- (2) Threads are not corroded, stripped, or blurred.
- (3) All seals, packings, and threads are coated with clean hydraulic fluid (C61 or C62).
- (4) All fittings and hose or tubing are properly aligned prior to tightening end connectors.

**CAUTION**

**Straightening bends in a used hose can result in hose becoming flattened and**

**kinked. Do not try to straighten bends in used hoses.**

- (5) Ensure hoses do not become twisted during tightening of end connectors or nuts.
- (6) Ensure hose is free to allow movement of components. Ensure hose does not have bends that will restrict fluid flow.
- (7) Spiral wrap all areas on hoses where chafing may occur. Use teflon tape (C128).
- (8) Ensure hoses are properly anchored to prevent chafing.
- (9) Torque hose end connectors (table 7-4) by using the dash number from the fittings that the hose will be connected to obtain the dash number from the part number stamped on the fittings or go to the parts manual. The last number is the dash number.

**Table 7-4. Torque Values for Fluid Connections  
\*AN 818 NUT (inch/pounds)**

Dash Number Reference	Tubing OD (Inches)	Al. Aly. Tubing (Flare AND 10061 or AND 10078)		Steel Tubing (Flare AND 10061)		Hose End Fittings and Hose Assemblies (MS 28740) (AN 6292)	
		Min.	Max.	Min.	Max.	Min.	Max.
—	0.125	—	—	—	—	—	—
- 3	0.187	—	—	90	100	70	100
- 4	0.25	40	65	135	150	70	120
- 5	0.312	60	80	180	200	85	180
- 6	0.375	75	125	270	300	100	250
- 8	0.50	150	250	450	500	210	420
-10	0.625	200	350	650	700	300	480
-12	0.75	300	500	900	1000	500	850
-16	1.0	500	700	1200	1400	700	1150
-20	1.25	600	900	—	—	—	—
-24	1.50	600	900	—	—	—	—
-28	1.75	—	—	—	—	—	—
-32	2.0	—	—	—	—	—	—

\*Flareless tubing connections shall be tightened as follows: Tighten the MS2192 nut one-sixth to one-third turns (one-half HEX flats) past the point of sharp torque rise on all sides and materials for all types of fittings or tubes.

**NOTE: The one-sixth to one-third turns (performed after the presetting operation) is the final installation torque.**

(10) Plug all open ends if hoses will not be connected immediately.

(11) Do not try to pull tubes into position by tightening nuts. Position tubes properly between connecting points to avoid stressing.

(12) Do not bend installed tubes. Remove tubes and bend to proper configuration, using proper tools.

(13) Spiral wrap all areas on tubes where they contact supports. Tape should extend a minimum of 0.375 inch from each end of support. Tape thickness to be 0.006 inch. Use insulation tape (C122).

(14) Ensure tubes are properly anchored to prevent chafing.

(15) Plug all open ends if tubes will not be connected immediately.

(16) Torque connectors of tubes. (Refer to table 7-4.) If leaks occur, back off connector and examine parts for damage, replace parts if necessary, and torque.

b. Installation of hoses, tubing or fittings applies only to damaged parts that were required to be removed from system, or attaching components, necessary to perform maintenance functions.

### 7 - 23 . **P**HYDRAULIC PUMPS (TRANSMISSION DRIVEN).

### 7-24. **P**DESCRIPTION – HYDRAULIC PUMPS (TRANSMISSION DRIVEN).

Dual hydraulic pumps are mounted on a drive quill located on the transmission lower case, and is accessible by opening right transmission cowling door (11, figure 2-3). System No. 1 pump is on aft pad of drive quill, and System No. 2 pump is on forward pad (figure 7-1 ).

### 7 - 25 . **P**REMOVAL – HYDRAULIC PUMPS (TRANSMISSION DRIVEN).

Either pump can be removed in the same manner.

a. Open right transmission cowling (11, figure 2-3). Place a suitable container under pump to catch spilled fluid.

b. Loosen hose nuts on SUCTION port fitting on outboard end of pump and pressure port fitting at

forward side. Allow fluid to drain into container. Disconnect both hoses. Cap hoses and fittings.

c. Disconnect hose from CASE DRAIN port fitting at top inboard on pump. Cap hose and fitting.

d. Disconnect hose from SEAL DRAIN port fitting at bottom inboard on pump. Cap hose and fitting.

e. Remove washers and nuts from four mounting studs at flange of pump. Pull pump and gasket from drive pad. Cover drive pad to protect from dirt.

f. If pump is being replaced, remove fittings from ports for use on replacement pump. Cover open pump ports. Protect driveshaft from dirt and damage.

### 7 - 26 . **P**LEANING – HYDRAULIC PUMPS (TRANSMISSION DRIVEN).



**Cleaning solvent is flammable and toxic. Provide adequate ventilation. Avoid prolonged breathing of solvent vapors and contact with skin or eyes. Eye protection is required when using compressed air.**

a. Clean external surface of pump with solvent (C112). A soft bristle brush maybe required to loosen caked dirt/grease deposit. Do not submerge pump in solvent.

b. Dry pump using clean filtered compressed air.

### 7-27. **P**INSPECTION – HYDRAULIC PUMPS (TRANSMISSION DRIVEN).

a. Inspect pump for leaks (table 7-1).

b. Inspect pump for cracks. No cracks are acceptable.

c. Inspect pump for security.

d. Inspect drive pad on transmission for leaks.

e. Inspect attaching hose connection for leaks.

f. Inspect pump for corrosion. Superficial corrosion is acceptable on external surfaces if polished out and treated for corrosion protection.

Corrosion on threads or internal parts is not acceptable.

**7-28. REPAIR OR REPLACEMENT — HYDRAULIC PUMPS (TRANSMISSION DRIVEN).**

a. Replace pump if damage in excess of limits (paragraph 7-27).

b. Polish out corrosion damage that is within repairable limits, use 600 grit sandpaper (C 102) and polish to original finish. Ensure that all traces of corrosion are removed, and that depth of repair does not exceed limits (paragraph 7-27).

c. Treat with chemical film (C31).

d. Touch up with primer (C88 or C91).

**7-29. INSTALLATION — HYDRAULIC PUMP (TRANSMISSION DRIVEN).**

Either pump can be installed in the same manner.

**CAUTION**

**Install P/N 212-076-364-3 or vendor P/N 2514-6 check valve in pump case drain port.**

a. Before installing fittings on new pump, remove case drain plug and drain preservative fluid from pump. Fill pump with clean hydraulic fluid (C61 or C62) and install check valve.

b. If pump is being replaced, install fittings from old pump at suction port on outboard end, pressure port on forward side, case drain port at top inboard end, and seal drain port at bottom inboard end. Use new packings.

c. Apply a thin film of antisieze compound (C21) to pump splines and to mating splines in transmission.

d. Position new gasket and pump to transmission drive pad. Engage pump shaft to splines of pad, and pump flange over four studs. Install washers and nuts on studs. Seal area around hydraulic pump and quill assembly mating flanges (paragraph 6-54.f.)

e. Connect hoses to suction, pressure, case drain and seal drain on port fittings.

f. Refill reservoir (paragraph 7-6). Bleed system. Check operation of system at next ground run-up of helicopter (paragraph 7-3).

**7-30. HYDRAULIC PUMP (EMERGENCY — ELECTRIC MOTOR DRIVEN).**

**7-31. DESCRIPTION - HYDRAULIC PUMP (EMERGENCY — ELECTRIC MOTOR DRIVEN).**

The emergency hydraulic system is powered by an electric motor driven, pressure compensated, variable delivery, hydraulic pump. The leading particulars for both the hydraulic pump and the electric motor are as follows:

Pump:

Rated discharge pressure	
Full flow	<b>1100</b> psig minimum
Zero flow	<b>1250</b> psig maximum
Rated inlet pressure	<b>10</b> psig
Rated full flow	<b>1.0</b> gpm minimum

Electric Motor

Rated voltage	<b>28</b> volt dc nominal
Rated current	<b>40</b> amperes maximum at full flow
	<b>180</b> amperes maximum at zero flow
Speed	<b>5400</b> rpm maximum at zero flow

**7-32. REMOVAL — HYDRAULIC PUMP (EMERGENCY – ELECTRIC MOTOR DRIVEN).**

a. Gain access to emergency hydraulic pump by removing access panel (17, figure 2-3).

b. Remove lockwire and disconnect electrical plug from pump assembly (4, figure 7-7).

c. Remove four bolts (5) and four washers (6) attaching pump assembly (4) to shelf.

d. Provide a suitable one gallon container. Place container under pump assembly directly below SUC-TION hose connection. Break torque on connector of tube (10) and allow fluid to drain from system slowly. It may be necessary to remove filler

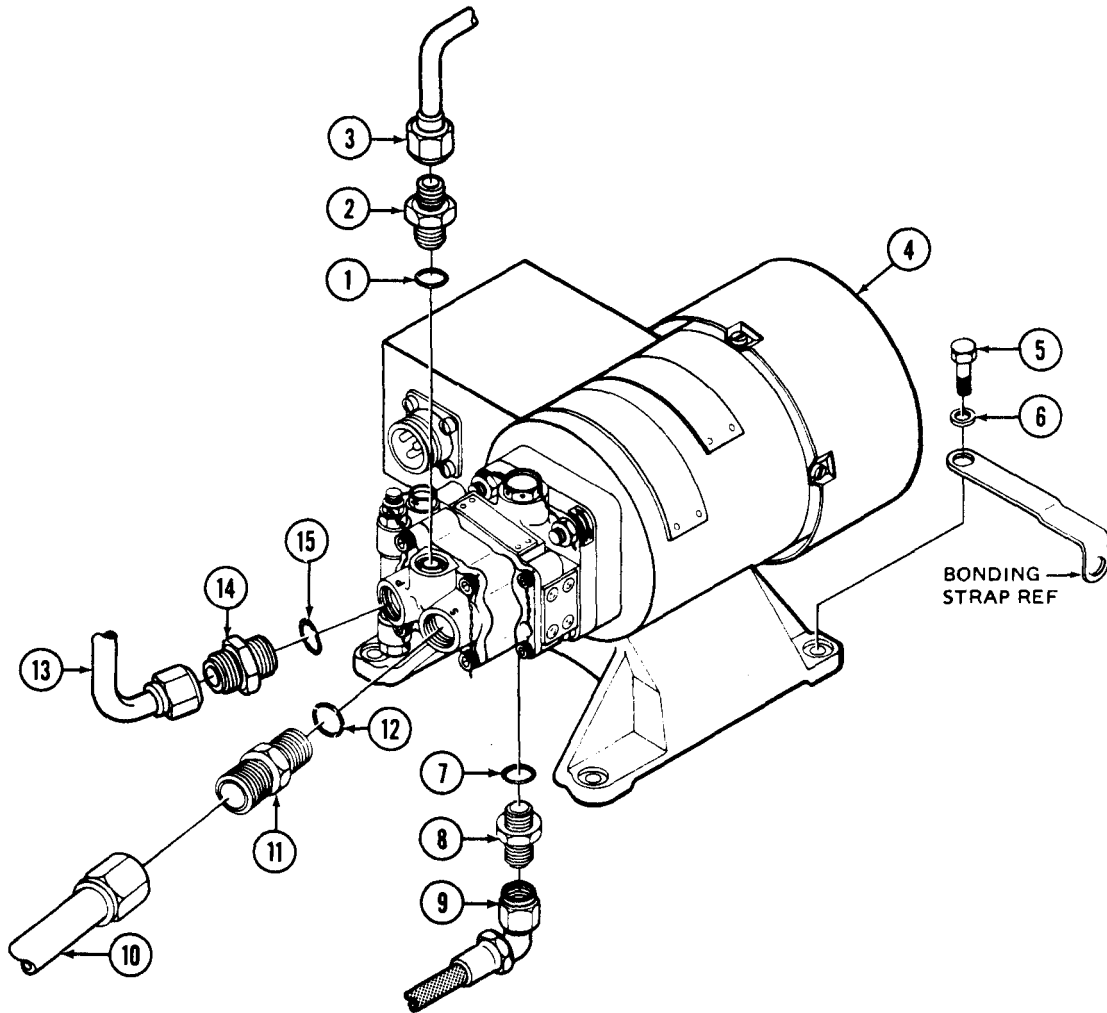

209076-63

- |                      |                               |
|----------------------|-------------------------------|
| 1. Packing           | 9. Hose assembly (seal drain) |
| 2. Fitting (union)   | 10. Tube (suction)            |
| 3. Tube (case drain) | 11. Fitting (union)           |
| 4. Pump assembly     | 12. Packing                   |
| 5. Bolt              | 13. Tube (pressure)           |
| 6. Washer            | 14. Fitting (union)           |
| 7. Packing           | 15. Packing                   |
| 8. Fitting (union)   |                               |

Figure 7-7. Emergency Electric Motor Driven Hydraulic Pump Installation

caps from all three reservoirs to allow better drainage. Remove tube (10) from fitting (11) and install protective dust cap to tube.

e. Remove tube (13) from fitting (14). Install protective dust cover to tube connector.

f. Remove tube (3) from fitting (2). Install protective dust cover to tube connector.

g. Remove hose assembly (9) from fitting (8) and remove pump assembly (4) from helicopter. Install protective dust cover to hose connector. Remove fitting (8) from pump assembly and discard packing (7).

h. Drain remainder of fluid from pump assembly.

i. Remove fitting (11) and discard packing (12) from pump assembly (4).

j. Remove fitting (2) from pump assembly (4). Remove packing (1) from fitting (2). Discard packing.

k. Remove fitting (14) from pump assembly (4). Remove packing (15) from fitting (14). Discard packing.

l. Clean pump assembly (paragraph 7-33).

m. Fill pump assembly (4) with hydraulic fluid (C61 or C62) and plug or cap all open port holes and electrical connector.

n. Wrap pump assembly in barrier material (C22) and secure with tape (C127). Send pump to next higher level of maintenance.

### 7-33 **P** CLEANING — HYDRAULIC PUMP (EMERGENCY-ELECTRIC MOTOR DRIVEN).

#### **WARNING**

**Cleaning solvent is flammable and toxic. Provide adequate ventilation. Avoid prolonged breathing of solvent vapors and contact with skin or eyes. Eye protection is required when using compressed air.**

#### **CAUTION**

**Do not submerge pump assembly (4, figure 7-7) in dry cleaning solvent as it will damage internal components.**

a. Wash pump assembly with a clean rag saturated with solvent (C112). A soft bristle brush maybe required to remove stubborn deposits of caked dirt and oil.

b. Dry pump assembly with clean filtered compressed air.

### 7-34 **P** INSPECTION—HYDRAULIC PUMP (EMERGENCY-ELECTRIC MOTOR DRIVEN).

#### **NOTE**

**The following inspection procedures are applicable to external surfaces and threaded bosses only. No internal inspections of the pump are authorized at this level of maintenance.**

a. Inspect hydraulic pump assembly (4, figure 7-7) for leaks (table 7-1).

b. Inspect pump/motor package for corrosion and mechanical damage. Damage within limits noted below is acceptable if polished out.

(1) Corrosion damage—maximum depth:

Hydraulic pump—0.015 inch (0.030 inch after cleanup).

Electric motor—0.030 inch (0.060 inch after cleanup).

(2) Nicks and scratches—maximum depth:

Hydraulic pump—0.030 inch (0.030 inch after cleanup).

Electric motor—0.060 inch (0.060 inch after cleanup).

(3) Dent or deformation—maximum depth:

Hydraulic pump—0.010 inch (0.030 inch after cleanup).



Electric motor — 0.050 inch (0.060 inch after cleanup).

**(4) Cracks:** No cracks are acceptable.

**c.** Inspect electrical connection to pump assembly (4) for corrosion, damaged threads, and bent or broken pins.

**d.** Inspect threaded ports in pump for damage. Maximum acceptable thread damage is one-third of thread depth 0.250 inch in length, and one damage per port.

### 7-35. REPAIR OR REPLACEMENT – HYDRAULIC PUMP (EMERGENCY – ELECTRIC MOTOR DRIVEN).

**a.** Replace pumps which fail to meet inspection requirements of paragraph 7-34.

**b.** Polish out mechanical and corrosion damage that is within repairable limits noted in paragraph 7-34. Use 600 grit sandpaper (C102) and polish to original finish.

**c.** Touch up with primer (C88 or C91).

### 7-36. **P** INSTALLATION – HYDRAULIC PUMP (EMERGENCY – ELECTRIC MOTOR DRIVEN).

**a.** Remove case drain plug from top of pump assembly and drain preservative fluid. Using hydraulic fluid dispenser (S1), fill pump with clean hydraulic fluid (C61 or C62) and install case drain plug. Secure case drain plug with lockwire (C137).

**b.** Install packing (1, figure 7-7) on fitting (2) and install fitting into CASE DRAIN port, located top center of pump.

**c.** Install packing (7) on fitting (8) and install fitting into SEAL DRAIN port located on lower end of pump.

**d.** Install packing (12) on fitting (11) and install fitting into SUCTION port, located on forward face of pump (outboard).

**e.** Install packing (15) on fitting (14) and install fitting into PRESSURE port, located on forward face of pump (inboard).

**f.** Remove protective dust covers from connectors of tubes (3, 10, and 13) and hose assembly (9). Check tube and hose connectors for thread damage.

**g.** Position pump assembly (4) on shelf and under bonding strap. Install four bolts (5), and four washers (6).

**h.** Install tubes (3, 10, and 13) to fittings (2, 11, and 14).



**Do not allow hose to chafe, twist or kink during installation. Ensure that hose is clear and clean.**

#### NOTE

**Hose connector shall be torqued in accordance with torque requirements outlined in table 7-4.**

**i.** Install hose (9) to fitting (8).

**j.** Connect electrical plug to pump assembly, lockwire (C137).

**k.** Perform operational check (paragraph 7-3).

### 7 - 3 7 **P** HYDRAULIC MODULAR UNITS.

#### 7-38. **P** DESCRIPTION – HYDRAULIC MODULAR UNITS.

Two hydraulic system modular units are located in a compartment at top of the fuselage between pilot canopy and the transmission pylon, on front of bulkhead at Station 186.25 (figure 7-4). Hinged doors (8, figure 2-3) at each side give access to the compartment. Each modular unit consists of a housing equipped with the system solenoid valve, relief valve, pressure switch for caution panel light, pressure and return filters, filter indicators (popout button), marked ports for system connections. Two quick-disconnect couplings are located on right modular unit for connection of hydraulic test stand (S2). One coupling is also used in normal operation for the return hose to the reservoir System No. 1 hydraulic modular unit is at left, and System No. 2 hydraulic modular unit at right on bulkhead.

### 7-39. **P** REMOVAL — HYDRAULIC MODULAR UNITS.

Either module can be removed in the same manner.

- a. Open left and right door (8, figure 2-3). Place a suitable container below module (figure 7-4) to catch spilled fluid.
- b. Disconnect electrical connectors from solenoid and pressure switch at top of module.
- c. Disconnect return line hose from quick-disconnect coupling on front of module, and four tubes from fittings at side ports. Cap fittings and open ends of tubes.
- d. Remove three bolts, with washers and nuts, to detach module from bulkhead. Remove module from compartment.
- e. If module is being replaced, remove fittings as necessary for use on replacement module.

### 7-40. **P** CLEANING — HYDRAULIC MODULAR UNITS.

- a. Clean electrical components with dry, filtered compressed air.



**Cleaning solvent is flammable and toxic. Provide adequate ventilation, Avoid prolonged breathing of solvent vapors and contact with skin or eyes. Eye protection is required when using compressed air.**



**Do not submerge hydraulic modular unit in dry cleaning solvent.**

- b. Wash modular unit externally with solvent (C112).

### 7-41. **P** INSPECTION — HYDRAULIC MODULAR UNITS.

- a. Inspect module unit for cleanliness.
- b. Inspect modular unit for leaks and malfunction during operational checks (paragraph 7-3).
- c. Inspect modular unit for security.
- d. Inspect modular unit for nicks, scratches, dents, cracks and corrosion.

### 7-42. **P** REPAIR OR REPLACEMENT — HYDRAULIC MODULAR UNITS. (AVIM)

- a. Replace modular units that fail to meet inspection requirements of paragraph 7-41.
- b. Touch up external finish with primer (C88 or C91).

### 7-43. **P** INSTALLATION — HYDRAULIC MODULAR UNITS.

Either module can be installed in the same manner.

- a. If module is being replaced, install serviceable fittings, and assemblies from old module as needed. Use new packings and gaskets.
- b. Position module to bulkhead, with pressure ports at outboard side. Align mounting holes. Insert three bolts through module housing and bulkhead, and install washers and nuts at back of bulkhead.
- c. Connect hydraulic system tubes to fittings at marked ports. Connect hose from reservoir RETURN port to quick-disconnect coupling.
- d. Connect electrical wiring connectors to solenoid valve and pressure switch.
- e. Perform operational check (paragraph 7-3).

### 7-44. **P** FILTER ELEMENTS.

**7-45. P DESCRIPTION – FILTER ELEMENTS.****NOTE**

The functions of the No. 3 Hydraulic System, Filter Element Assembly Indicator button, is identical to that of the Nos. 1 and 2 Systems.

Two filter elements (figure 7-8) are installed in each of the two hydraulic modular units. The filter elements are enclosed in filter bowls. Filter elements are inspected at intervals specified in Preventive Maintenance Checklists. The filter elements are also inspected when indicator buttons on pressure indicator assemblies pop out, except when indicators are reset (pushed in) and do not pop out a second time. Also, the filter elements do not require inspection when indicator buttons pop out and the condition is known to be caused by fluid temperature below 20 degrees F (-7 degrees C).



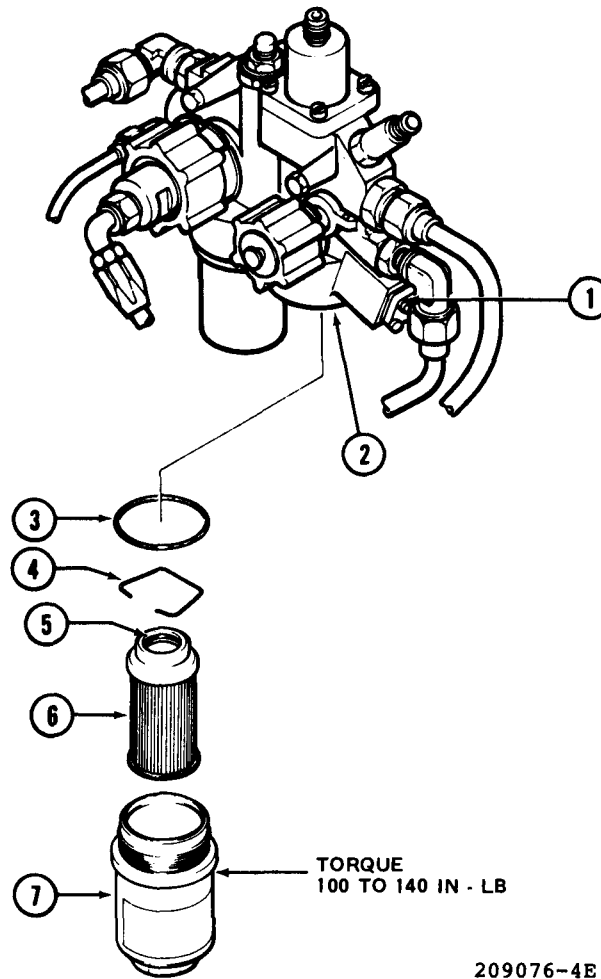

- 1. Pressure indicator assembly
- 2. Module housing
- 3. Packing
- 4. Element retainer
- 5. Packing
- 6. Filter element
- 7. Filter bowl

Figure 7-8. Filter Element Installation

Premaintenance Requirements for Filter Element

Premaintenance Requirements for Filter Element		Conditions	Requirements
Condition	Requirements	Minimum Personnel Required	One
Model	AH-1S	Consumable Materials	(C31) (C61) (C62) (C88) (C91) (C102) (C112) (C137)
Part No. or Serial No.	All	Special Environmental Conditions	Clean, dust-free area
Special Tools	None		
Test Equipment	None		
Support Equipment	(S1)(S10)		

**7-46. P REMOVAL—FILTER ELEMENTS.**

- a. Open left compartment door (8, figure 2-3). Place a suitable container below module to catch fluid.
- b. Remove lockwire and remove filter bowl (7, figure 7-8).
- c. Remove packing (3).
- d. Remove element retainer (4).

**NOTE**

**Filter elements must be replaced when spectrometric analysis fluid sample shows signs of contamination.**

- e. Examine filter element and all fluid in filter bowl for unusual contamination which might indicate need for corrective action beyond replacement of filter element.
- f. Remove packing (5).
- g. Remove remaining filter elements in the same manner outlined in steps a. through f.

**747. P CLEANING—FILTER ELEMENT.**

Do not clean paper-type filter elements.

**748. P INSPECTION—FILTER ELEMENTS.**

Refer to paragraph 7-46, step e.

**749. P REPAIR OR REPLACEMENT—FILTER ELEMENTS.**

Install new paper-type filter elements P/N 205-076-034-3.

**7-50. P INSTALLATION—FILTER ELEMENTS.**

- a. Wipe filter bowl (7, figure 7-8) and mating surfaces of module housing (2) clean with a clean cloth.
- b. Install new packing (3) into groove in housing (2).
- c. Install new packing (5) in filter element (6).
- c.1 Fill filter bowl 3/4 full of clean hydraulic fluid (C61 or C62).
- d. Insert new filter element (6) in filter bowl (7) and install filter retainer (4).

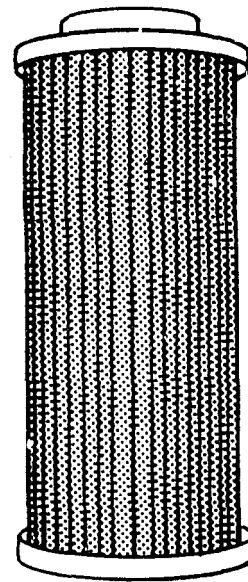

**NON-CLEANABLE**

**PIN 205-076-034-3**

**Figure 7-9. Non-Cleanable Filter Element**

- e. Install filter bowl (7) and filter element on module housing (1). Torque filter bowl 100 TO 140 inch-pounds. Secure filter bowl to housing with lockwire (C-137).

**NOTE**

**Torque emergency system filter bowl 20 to 60 inch-pounds.**

- f. Install other filter elements in the same manner.
- g. Perform ground runup and inspect for hydraulic fluid leaks.

**7-51. P ACCUMULATOR AND LOCKOUT VALVE.**

**7-52. P DESCRIPTION—ACCUMULATOR AND LOCKOUT VALVE.**

The hydraulic accumulator and lockout valve assembly (figure 7-10), in System No. 1 pressure line to cyclic control hydraulic cylinders, is located on a

bracket beneath the pylon lift beam. The accumulator and lockout valve are automatic in operation, with no electrical or manual controls, and do not require any charging procedure. The lockout valve is interchangeable with the valve used in the collective controls hydraulic circuit. System No. 2 has a lockout valve only.

**7-53. P REMOVAL — ACCUMULATOR AND LOCKOUT VALVE.**

- a. Remove left access panel (17, figure 2-3).
- b. Place a suitable container below accumulator and valve assembly to catch trapped fluid.

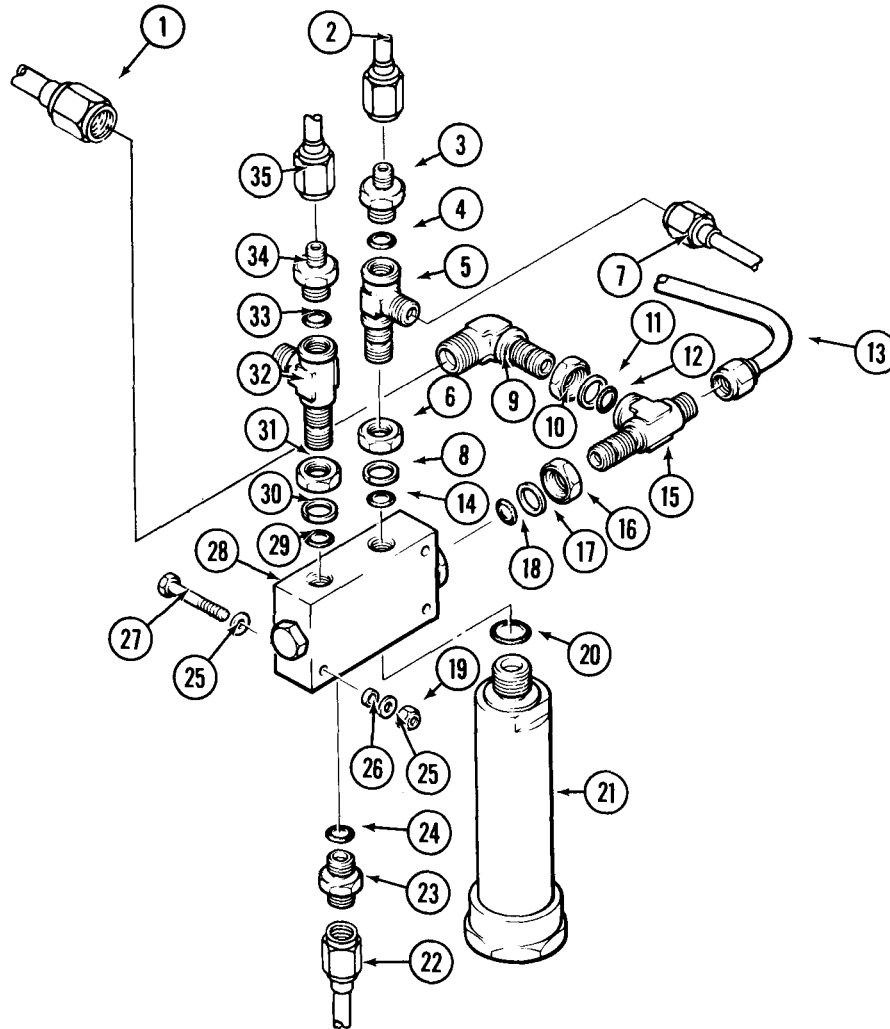

- |                   |                          |                            |
|-------------------|--------------------------|----------------------------|
| 1. Tube assembly  | 13. Tube assembly        | 25. Washers                |
| 2. Tube assembly  | 14. Packing              | 26. Spacer                 |
| 3. Fitting        | 15. Tee                  | 27. Bolt                   |
| 4. Packing        | 16. Nut                  | 28. Lockout valve assembly |
| 5. Tee            | 17. Ring (backup)        | 29. Packing                |
| 6. Nut            | 18. Packing              | 30. Ring (backup)          |
| 7. Tube assembly  | 19. Nut                  | 31. Nut                    |
| 8. Ring (backup)  | 20. Packing              | 32. Tee                    |
| 9. Elbow          | 21. Accumulator assembly | 33. Packing                |
| 10. Nut           | 22. Tube assembly        | 34. Fitting                |
| 11. Ring (backup) | 23. Fitting              | 35. Tube assembly          |
| 12. Packing       | 24. Packing              |                            |

209076-52A

Figure 7-10. P Accumulator and Lockout Valve Installation

c. Using care to avoid spraying of fluid, if any pressure is still trapped, remove tubes (1, 2, 7, 13, 22 and 35, figure 7-10). Cap all tube connectors.

d. Remove three nuts (19), six washers (25), three spacers (26) and three bolts (27) attaching lockout valve (28) to bracket and remove lockout valve (with accumulator (21), from helicopter. Drain fluid from lockout valve.

e. Place lockout valve (28) (with accumulator (21) on clean work bench and remove attaching components from lockout valve as follows:

f. When replacing accumulator assembly (21) proceed as follows:

(1) Remove accumulator assembly (21) from lockout valve assembly (28).

(2) Remove packing (20) from accumulator assembly (21) and discard packing.

(3) Remove container located below accumulator.

g. Remove accumulator (21) from lockout valve (28) and remove packing (20) from accumulator.

(1) Remove fitting (23) and packing (24) from lockout valve (28).

(2) Break torque on nut (16) and remove tee (15) from lockout valve (28). Break torque on nut (10) and remove elbow (9) from tee (15). Remove packing (12), ring (11) and nut (10) from elbow (9). Remove packing (18), ring (17) and nut (16) from tee (15).

(3) Remove fitting (3) from tee (5). Remove packing (4) from fitting.

(4) Break torque on nut (6) and remove tee (5) from lockout valve (28). Remove packing (14), ring (8) and nut (6) from tee (5).

(5) Remove fitting (34) from tee (32). Remove packing (33) from fitting.

(6) Break torque on nut (31) and remove tee (32) from lockout valve (28). Remove packing (29), ring (30) and nut (31) from tee (32).

h. Remove container from helicopter.

## 7-54. **P** CLEANING – ACCUMULATOR AND LOCKOUT VALVE.

### **WARNING**

**Cleaning solvent is flammable and toxic. Provide adequate ventilation. Avoid prolonged breathing of solvent vapors and contact with skin or eyes. Eye protection is required when using compressed air.**

a. Clean external surfaces of accumulator and lockout valve by wiping with a clean cloth moistened with solvent (C112), but do not allow solvent to enter units.

b. Dry accumulator and lockout valve with filtered compressed air.

## 7-55. **P** INSPECTION – ACCUMULATOR AND LOCKOUT VALVE.

a. Inspect accumulator (21) and lockout valve (28) for nicks, scratches, corrosion and cracks.

b. Inspect fittings, tube connectors, ports of lockout valve and accumulator, and nuts for thread damage.

c. Inspect accumulator (21) and lockout valve (28) for cleanliness and security.

## 7-56. **P** REPAIR OR REPLACEMENT – ACCUMULATOR AND LOCKOUT VALVE. (AVIM)

a. Any cracks to fittings, nuts, accumulator or lockout valve requires replacement of part. No repairs allowed.

b. Replace all packings and rings (backup).

c. Replace accumulator or lockout valve or both if malfunction or damage occurs. No repairs allowed.

d. Minor nicks, scratches, and corrosion to exterior surface of lockout valve of accumulator is acceptable, provided the damaged area is polished out with 600 grit sandpaper (C102) to the original finish and treated with chemical film (C31). Touchup repair area with primer (C88 or C91).





Do not mix hydraulic fluids (C62) and (C63).

e. Any corrosion to internal area of lockout valve or accumulator, requires replacement of part. No repairs allowed.

**7-57. P INSTALLATION – ACCUMULATOR AND LOCKOUT VALVE.**

a. Remove protective dust covers from replacement lockout valve (28, figure 7-10).

b. Install attaching components to replacement lockout valve (28) as follows:

(1) Provide a clean work area. Place packing (4) on fitting (3) and install fitting into tee (5).

(2) Place packing (33) on fitting (34) and install fitting into tee (32).

(3) Install nut (31), ring (30) and packing (29) on tee (32). Thread tee (32) into SYS RET port; position tee as shown and tighten nut (31).

(4) Install nut (6), ring (8) and packing (14) on tee (5). Thread tee (5) into SYS PRESS port; position tee as shown and tighten nut (6).

(5) Install nut (16), ring (17) and packing (18) on tee (15). Thread tee (15) into PRESS port (located on opposite end from valve spring housing); position tee as shown and tighten nut (16).

(6) Install nut (10), ring (11) and packing (12) on elbow (9). Thread elbow (9) into tee (15); position elbow (9) shown and tighten nut (10).

(7) Place packing (24) on fitting (23) and install fitting into RES RET port.

(8) Place packing (20) on accumulator (21) and install accumulator into open port adjacent to RES RET port.

c. Position accumulator/lockout valve to bracket and install three bolts (27), six washers (25), three spacers (26) and three nuts (19).

d. Remove protective dust covers from end connectors of tubes (1, 2, 7, 13, 22 and 35) and connect tubes to lockout valve. Torque tube end connector in accordance with torque requirements outlined in table 7-4.

e. Using hydraulic fluid dispenser (S1), service all three hydraulic reservoirs with clean hydraulic fluid (C61 or C62) to proper fluid level.

f. Bleed hydraulic System and perform operational check (paragraphs 7-3 and 7-6).

**7-58. P DUAL HYDRAULIC CYLINDERS.**

**7-59. P DESCRIPTION – DUAL HYDRAULIC CYLINDERS.**

Three dual hydraulic actuating cylinders are used in collective, lateral cyclic, and fore-and-aft cyclic controls (figure 7-3). Each cylinder assembly consists of a dual cylinder and valve combination, a bearing and housing, and an extension tube on the cylinder piston rod. All three have the same cylinder and valve group, but use different extension tubes. Valves and rod end bearings are aligned in each assembly by locks in slots provided.

**Premaintenance Requirements for Dual Hydraulic Cylinders**

Condition	Requirements
Model	AH-1S
Part No. or Serial No.	209-076-362-1, -3, and -5
Special Tools	(T22) (T23)
Test Equipment	None
Support Equipment	(S1) (S10)
Minimum personnel Required	Two
Consumable Materials	(C43) (C61 ) (C62) (C88) (C91) (C112) (C137)
Special Environmental Conditions	Clean, dust free area

**7-60. P REMOVAL – DUAL HYDRAULIC CYLINDERS.**

a. Any of three cylinder assemblies can be removed by the same typical procedure.



**Before loosening any connections in accumulator circuit, ensure trapped hydraulic pressure is released.**

(1) Open left and right transmission cowl assemblies (11, figure 2-3). Remove left and right access panels (17) on side of fuselage below wing. Install maintenance platform (S10) on helicopter.

(2) Disconnect control tube (22, figure 7-3) from control valve lever (21) by removing cotter pin, nut, bolt, and washers. Disconnect control tubes (6 and 7) in the same manner.

(3) Place a container to catch spilled fluid. Disconnect hydraulic hoses from lower end of valve (19). Cap open hoses and fittings.

(4) Open left and right pylon access doors and disconnect rod end bearing (2, figure 7-3) at top of cylinder tube from swashplate horn (3) or collective lever (4) by removing cotter pin, nut, bolt, and washers. Remove control tubes (6, 7, and 22).

(5) Hold bolts (24) with work aid shown on figure 7-11. Remove nuts (28, figure 7-3), washers (27), washers (25), and bolts (24).

(6) Loosen hydraulic connections as necessary to provide clearance for removal.

(7) Turn valve (19) as necessary to pass through hole in support (8 or 18). Remove cylinder assembly (5, 9, or 17).

### 7-61. P DISASSEMBLY - DUAL HYDRAULIC CYLINDERS. (AVIM)

a. Cyclic (lateral) Dual Hydraulic Cylinder. Disassemble cyclic: dual, lateral hydraulic cylinder assembly.

(1) Remove sealant from threads of rod end bearing (1, figure 7-12), lock (2), and nut (3).

(2) Cut lockwire, loosen nut (3) and remove rod end bearing (1) from end of tube (4). Remove nut (3) and lock (2). Remove sealant from threads of nut, rod end bearing and lock.

(3) Remove clamps (5) from dust protective boot and flange assembly (6). Slide boot up and remove boot from cylinder assembly (23).

(4) Remove lockwire from nuts (11 and 12).

(5) Place torque fixture (T22 or T23) in suitable vise and install cylinder assembly in fixture (figure 7-13). While holding cylinder piston rod from rotating, loosen nut (11, figure 7-12). Remove nut (11) and spring (13) from cylinder assembly (View B-B, figure 7-12).

(6) Remove lockwire from lock (15 and nut (12).

(7) While holding cylinder piston rod to prevent rotation, loosen nut (12) and back nut off from tube (4). Remove tube (4), nut (12), lock (15), and base (14) from piston rod of cylinder assembly (view B-B, figure 7-12).

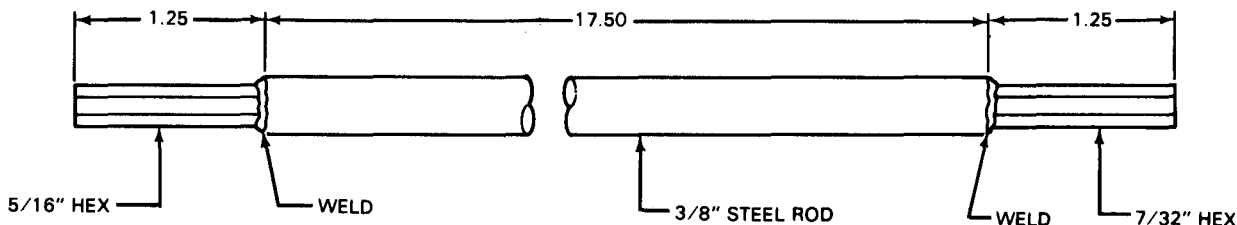

ALL DIMENSIONS ARE IN INCHES UNLESS OTHERWISE NOTED

209900-516A

Figure 7-11. Work Aid for Dual Hydraulic Cylinder Removal and Installation

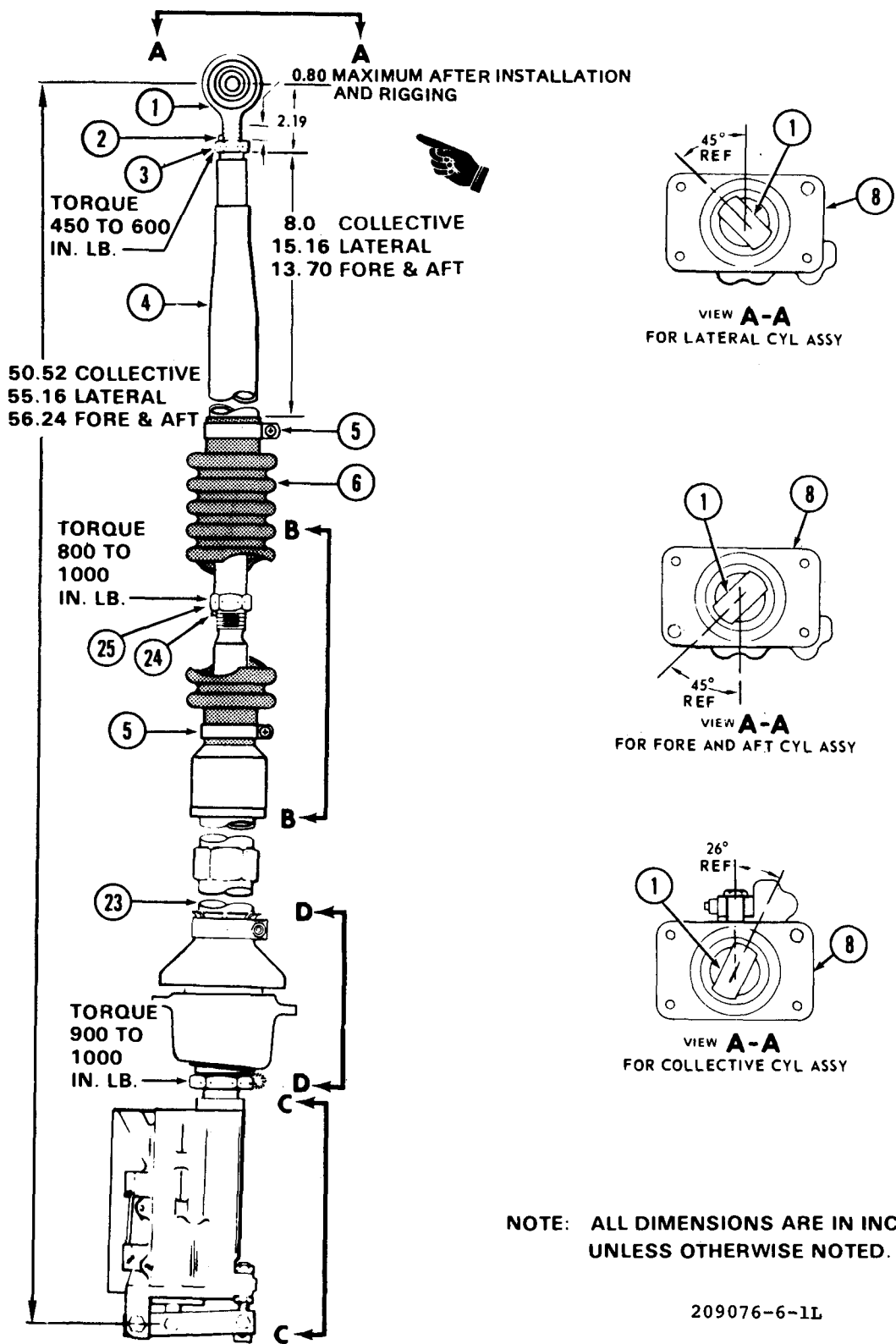
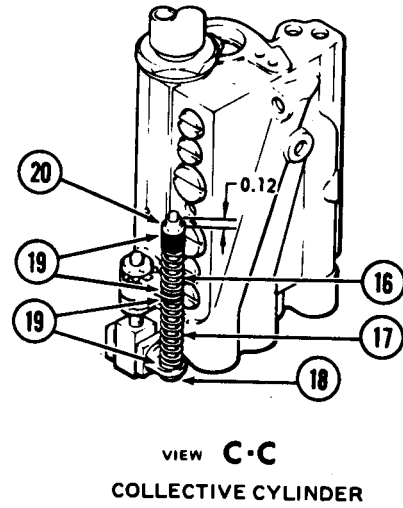
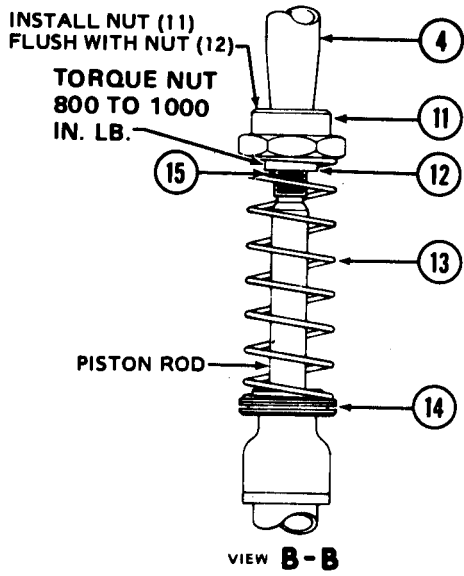
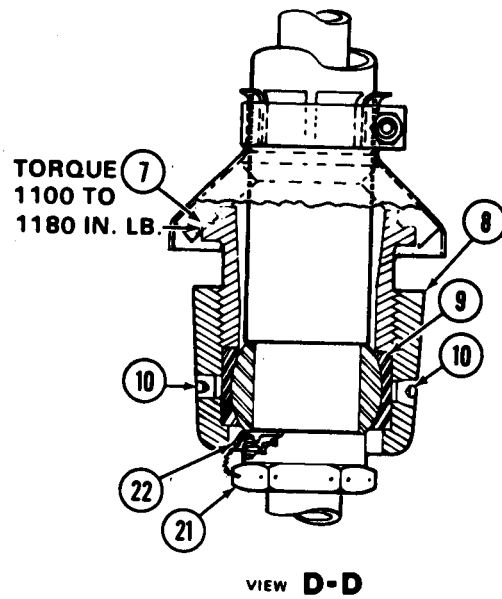

Figure 7-12. Dual Hydraulic Cylinder (Sheet 1 of 2)



1. Rod end bearing
2. Lock
3. Nut
4. Tube
5. Clamp
6. Boot/flange assembly
7. Nut
8. Housing
9. Bearing
10. Plug
11. Nut
12. Nut
13. Spring
14. Base
15. Lock
16. Spring (0.034 dia. wire)
17. Spring (0.047 dia. wire)
18. Bolt
19. Washers (4 required)
20. Nut
21. Nut
22. Tab washer
23. Cylinder assembly
24. Lock
25. Nut



209076-6-2J

Figure 7-12. Dual Hydraulic Cylinder (Sheet 2 of 2)

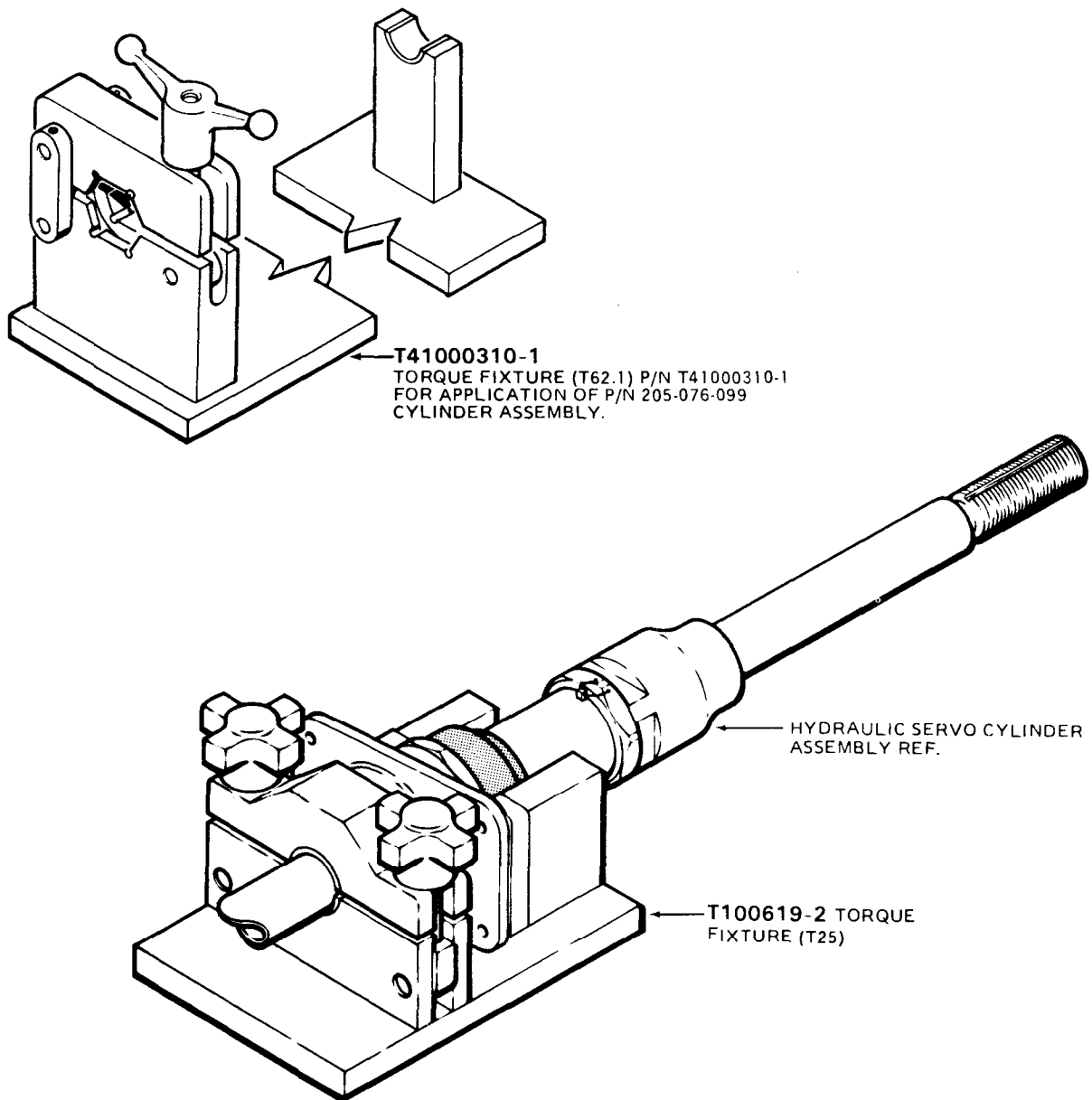

205001-1054A

**Figure 7-13. Tool Application — Cylinder Assembly Torque Fixture  
Part Numbers T41000310-1 and T100619-2**

**(8)** Remove pressure and return fittings.

**(9)** Remove cylinder assembly from torque fixture (T22 or T23).

**b.** Cyclic (Fore and Aft) and Collective Dual Hydraulic Cylinders. Disassemble cyclic (fore and aft) and collective dual hydraulic cylinder assemblies as follows:

**(1)** Remove sealant from threads of rod end bearing (1, figure 7-12), lock (2) and nut (3).

**(2)** Remove lockwire from lock (2) and nut (3) and remove rod end bearing (1) from tube (4). Clean sealant from threads of nut, rod end bearing and from lock.

**(3)** Remove clamp (5) from upper and lower end of boot/flange assembly (6). Slide boot up and remove boot/flange assembly from tube (4).

(4) Remove lockwire from lock (24) and nut (25).

(5) Place torque fixture (T22 or T23) in suitable vise and install cylinder assembly in fixture (figure 7-13). While holding cylinder piston rod from rotating, loosen nut (25, figure 7-12) and back off nut from tube (4). Remove tube (4), nut (25), and lock (24) from cylinder piston rod.

(6) Remove cylinder assembly from torque fixture (T22 or T23).

(7) Remove pressure and return fittings from bottom of servo valve.

(8) Remove springs (16 and 17) from collective servo valve by removing nut (20), washers (19), and bolt (18).

#### 7-62. **P** CLEANING – DUAL HYDRAULIC CYLINDERS.



Cleaning solvent is flammable and toxic. Provide adequate ventilation. Avoid prolonged breathing of solvent vapors and contact with skin or eyes. Eye protection is required when using compressed air.

a. Clean external surfaces, except polished surfaces of piston rod and control valve by wiping with a clean cloth moistened with solvent (C112).

b. Carefully clean exposed polished surfaces of piston rod and control valve with a soft cloth moistened with hydraulic fluid (C61 or C62).

#### 7-63. **P** INSPECTION – DUAL HYDRAULIC CYLINDERS.

a. Inspect all parts for damage, corrosion or pitting, and exposed threads for distortion:

(1) No elongation in holes is acceptable.

(2) Black residue around the piston rod is not a reason for replacement of the servo cylinder.

b. Inspect piston rod for nicks, scratches; or scoring, and for smooth operation in cylinder. A

friction drag of approximately 2.5 pounds is considered normal.

c. Check bearing installation for looseness or binding. To check the bearing installation, perform the following:

#### NOTE

When the part number of the cylinder assembly is 209-001-362, the bearing part number will be KSP 6099-1. The required friction has been built into this bearing during manufacture and it requires no additional adjustment. The bearing is designed to gimbal freely, thus does not have the characteristic tightness of the uniball bearing which requires the spring scale torque test. The rotational freedom of the KSP 6099-1 bearing should not be interpreted as wear and the axial movement should not be considered as excessive unless feedback is felt in the controls. The bearing requires no lubrication and plugs should be installed in grease fitting holes. Installation of KSP 6099-1 bearing requires that the bearing housing retaining nut be torqued 1100 to 1180 inch-pounds to secure it to the servo cylinder. This torque does not affect the friction on the bearing. When the KSP 6099-1 bearing is installed, the KSP 9059 shield and KSP 9056 seal must also be installed. Do not use the rubber boot assembly used on other servo cylinder assemblies. Only one positive safety is required for this installation.

(1) Disconnect the cyclic and collective servo actuator upper control tubes from the swashplate.

(2) Disconnect the push-pull tubes from the bottom of all three servo actuators.

(3) Bottom servos in full up position. Inspect servo valve for serviceability. Check selector set for sticking or binding. Inspect lever stop for distortion. Inspect bolts through arm lever for wear and distortion; bolts (20, figure 7-3) to be finger tight only. Check cotter pins for security. Inspect bearing

housing (8, figure 7-12) for damage and flange for cracks and elongation of holes; holes not to exceed **0.001** inch beyond dimensions shown in view A, figure 7-15.

(4) Attach a pound reading spring scale to the clevis or rod end at the top of the control tube. Working with each servo independently, move the actuators laterally until they bottom out. A force of 1 to 2.5 pounds should be required to move bearing through its full travel with the servo fully extended.

(5) If the force required to move the bearing is above or below the requirements established in step (4) above, lubricate bearing. (Refer to Chapter 1.) Recheck force as outlined in step (4). If force is not within limits, torque bearing housing nut (29, figure 7-3) **400 to 450** inch-pounds. Recheck force. If force is not within limits, correct as follows:

(6) Torque lower retaining nut (21, figure 7-12) **900 to 1000** inch-pounds. Make sure nut is safetied properly with tab washer (22).

#### NOTE

**To properly assemble tab washer on cylinder assembly, fit the tab on the inside of washer into machined slot of cylinder barrel before retainer nut is tightened.**

(7) Torque the bearing housing nut (29, figure 7-3) **400 to 450** inch-pounds to ensure proper seating of the bearing surfaces.

(8) Loosen nut (29) and retorqued until a force of **1 to 2.5** pounds is required to move cylinder laterally.

(9) Double lockwire retaining nut 180 degrees apart. One lockwire shall be a positive lock and one negative. Paint slip marks on bearing retaining nut and bearing housing.

#### NOTE

**It is permissible for the main rotor cylinder barrel to rotate within the housing assembly providing there is no vertical barrel movement. When vertical movement is apparent, retorqued the lower retaining nut (21, figure 7-12). Recheck force required to move the cylinder. Refer to step (8) above.**

#### NOTE

**Ensure support mounts are lubricated every 150 hours of operation. To properly grease, detach the rod end from the pitch control lever or swashplate horn. Rotate the cylinder assembly in the bearing housing while applying grease. Rotating the cylinder will assure complete lubrication of the bearing. Assemble rod end to the pitch control lever or to swashplate horn.**

(10) Reinstall and safety all control tubes previously removed in steps (1) and (2) above.

d. Inspect cylinder assembly for leaks at all connections and fittings. Seepage around piston rod seals during operation is acceptable, but not to exceed **one** drop every **20** cycles. The maximum leakage allowed at the cylinder bleed hole is **3** drops in **25** cycles. Accumulation of the equivalent of one drop of static leakage at the valve and sleeve assembly in **24** hours is acceptable.

e. Inspect shield for security.

f. Inspect nuts and locks for proper safetying in accordance with TM 55-1500-204-25/1.

g. Collective flight control cylinder (AVIM).

(1) Inspect rod end bearing for roughness and freedom of movement.





(2) Inspect lock (2, figure 7-12) for cracks and deformity.

(3) Inspect tube (4) and rod end bearing (1) for mechanical, corrosion and thread damage. Refer to paragraph 11-150 for damage limits on flight control tubes.

(4) Inspect nut (25) for cracks and for damaged threads.

(5) Inspect lock (24) for cracks and deformity.

(6) Remove and visually inspect servo springs (16 and 17) and bolt (18) for excessive wear.

h. Fore and aft and lateral control cylinders (AVIM).

(1) Inspect rod end (1) for roughness and for freedom of movement.

(2) Inspect nut (3) for cracks and for damaged threads.

(3) Inspect locks (2, 15 or 24) for cracks and deformity.

(4) Inspect tube (4) for cracks and for damaged threads.

(5) Inspect nut (25) for cracks and for damaged threads.

(6) Inspect spring (13) for cracks and for free length of spring, which must be **8.9 TO 9.2** inches in length. Compress the spring **6** inches and release. Remeasure spring length. If spring is shorter, replace the spring.

(7) Inspect spring base (14) and nut (11) for cracks, excessive wear and bonded washers for adhesion.

#### 7-64. **P** REPAIR OR REPLACEMENT — DUAL HYDRAULIC CYLINDERS.

a. Replace protective boot or attaching parts if damaged or unserviceable.

b. Replace cylinders that fail to meet inspection requirements.

c. When replacing cylinder assembly, check that overall length is correct for control system location (figure 7-15). Servo cylinders are interchangeable, but

extension tubes are different lengths for use in collective, lateral, and fore-and-aft controls.

d. During reassembly, set rod end dimensions first, then adjust assembly length by screwing tube on cylinder piston rod (figure 7-15). Use locks in slots to obtain correct alignment, torque nuts as shown, and secure nuts and locks with lockwire (C137).

#### NOTE

**Assembly dimensions shown on figures 7-12 and 7-15 are nominal and are subject to change during rigging (chapter 11).**

e. When replacing servo cylinder in an assembly, perform the following:

(1) After removing rod end and tube, inspect fittings in upper and lower ends of tube for corrosion in internal areas.

(2) If corrosion is present, replace the tube. If replacement is not available, tube maybe temporarily kept in service by applying preventive compound (C43) to retard corrosion until tube can be replaced at next scheduled maintenance inspection.

(3) Before installing a new tube, flush internal surfaces with primer (C88 or C91). Stop one end of tube, pour primer into other end, rotate tube to obtain full coverage of primer in both end fittings, and drain for **10 TO 20** minutes before installation.

#### NOTE

**On a new complete cylinder assembly, tube can be left in place and treated as in step (3) above by removing rod end to apply primer.**

**Assembly directions shown on figures 7-12 and 7-15 are nominal and are subject to change during rigging (chapter 11).**

e. Any damage to nut (7) requires replacement of cylinder assembly. Damage to bearing housing (8) in excess of limits shown on figure 7-14 requires replacement of cylinder assembly. Send cylinder assembly to next higher maintenance level.

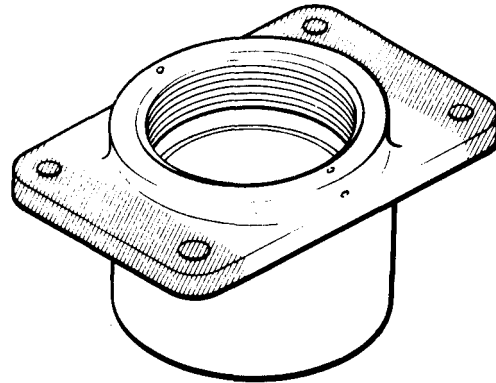

204-076-317-7  
HYDRAULIC CYLINDER  
BEARING HOUSING

**DAMAGE LOCATION SYMBOLS**

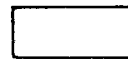
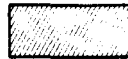

TYPE OF DAMAGE	MAXIMUM DEPTHS AND REPAIR AREAS ALLOWED	
CRACKS ALLOWED	None	None
NICKS, SCRATCHES, AND SHARP DENTS	0.020	0.040
CORROSION	0.010	0.020
MAXIMUM AREA PER FULL DEPTH REPAIR	0.10 Sq. In.	Not critical
NUMBER OF REPAIRS	Not critical	Not critical
EDGE CHAMFER	0.040	0.060
BORE DAMAGE	0.002 for 1/2 circumference	
THREAD DAMAGE:		
DEPTH:	One-third of thread	
LENGTH:	cumulative	
NUMBER:		

ALL DIMENSIONS ARE IN INCHES UNLESS OTHERWISE NOTED

209076-28E

**Figure 7-14. Damage Limits For Hydraulic Cylinder Bearing Housing**

f. On lateral system cylinder, install base (14, figure 7-12), spring (13), lock (15), nut (11), and nut (12). Install nut (11), and nut (12). Install nut (11) flush with nut (12). See view B-B.

g. On collective system cylinder, check that two springs (16 and 17) are installed on valve as shown.

h. Collective Flight Control Cylinder (AVIM).

(1) Redate rod end, nuts, and locks if they fail inspection.

(2) Repair minor surface damage on tube (4), that is within allowable limits. Refer to paragraph 11-150 for repair procedure on flight control tubes. Replace rod end bearing (1) if damaged. Replace tube (4) if mechanical damage is in excess of acceptable limits.

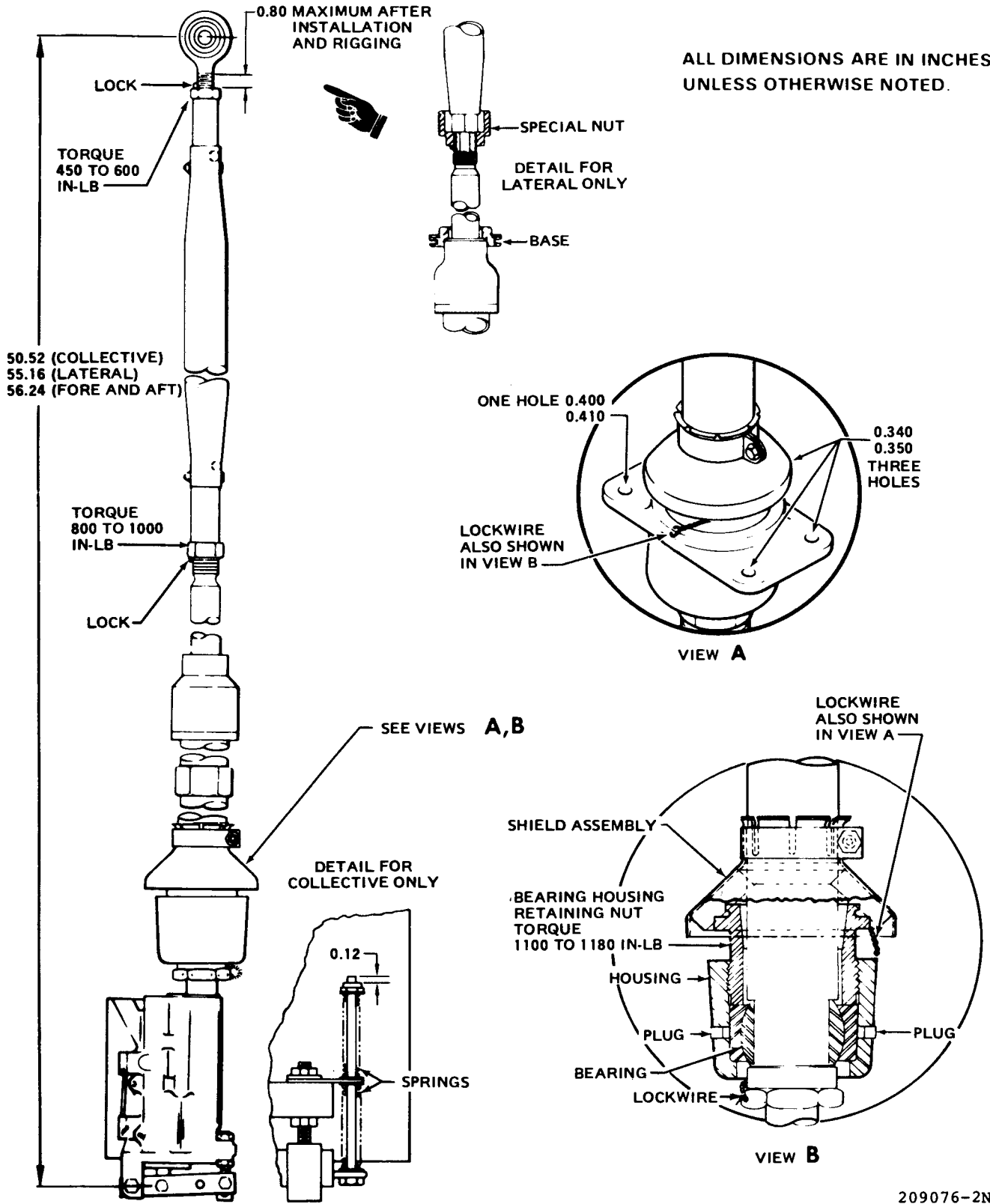

Figure 7-15. Dual Hydraulic Cylinder Assembly (Typical)

(3) Deleted.

(4) Replace excessively worn servo springs (16 and 17) and bolts (18).

i. Fore and aft lateral control cylinders (AVIM).

(1) Repair leaking servo cylinder as follows:

(a) Cut and remove lockwire securing cylinder lock nut (1, figure 7-16) to lock (2) and loosen lock and locknut from upper end of cylinder.

(b) Unscrew cap (3) from cylinder.

(c) Remove packing retainers (4) and packing (5) from inside cap (3) and replace with like serviceable items.

(d) Remove internal retainer ring (10) from cap (3).

(e) Remove two scraper rings (8), scraper ring retainer (9) from cap (3), and replace with like serviceable items.

(f) Remove packing (6) and packing retainer (7) from cap (3) and replace with like serviceable items.

(g) Install retainer ring (10) in cap (3).

(h) Screw cap (3) on upper end of cylinder and tighten until it bottoms out then loosen sufficiently to allow alignment of lock (2).

(i) Position locknut (1) against cap (3) and torque locknut **250-300 inch-pounds**. Install lock (2) and secure to locknut with lockwire (C137).

(2) Replace lock (2) if damaged or broken as follows:

(a) Remove cap (3).

(b) Remove locknut (1) and lock (2) from cylinder.

(c) Install lock (2) in keyway of cylinder and screw locknut (1) and lock (2) on cylinder.

(3) Repair leaking bleed plug in pilot valve as follows:

(a) Remove bleed plug (12) from pilot valve (13).

(b) Remove packing (11) from body of bleed plug (12) and replace with new packing.

(c) Replace bleed plug (12) in pilot valve and tighten.

(4) Clean filters (14 and 15) with clean, dry filtered compressed air. Remove packings (16 and 17) and replace with new packing.

**7-65. P ASSEMBLY — DUAL HYDRAULIC CYLINDERS (AVIM).**

**Premaintenance Requirements for Dual Hydraulic Cylinder Assembly**

Condition	Requirements
Model	AH-1S
Part No. or Serial No.	209-001-362-1, -3, -5
Special Tools	(T22) (T23)
Test Equipment	None
Support Equipment	(S2) (S10)
Minimum Personnel Required	One
Consumable Materials	(C22) (C61) (C62) (C69) (C105) (C112) (C127) (C137) (C138)
Special Environmental Conditions	None

a. Fore and Aft Cyclic and Collective Dual Hydraulic Cylinders. Assemble fore and aft cyclic and collective dual hydraulic cylinder assemblies as follows:

(1) Place torque fixture (T22 or T23) in suitable vise and install cylinder assembly in fixture (figure 7-13).

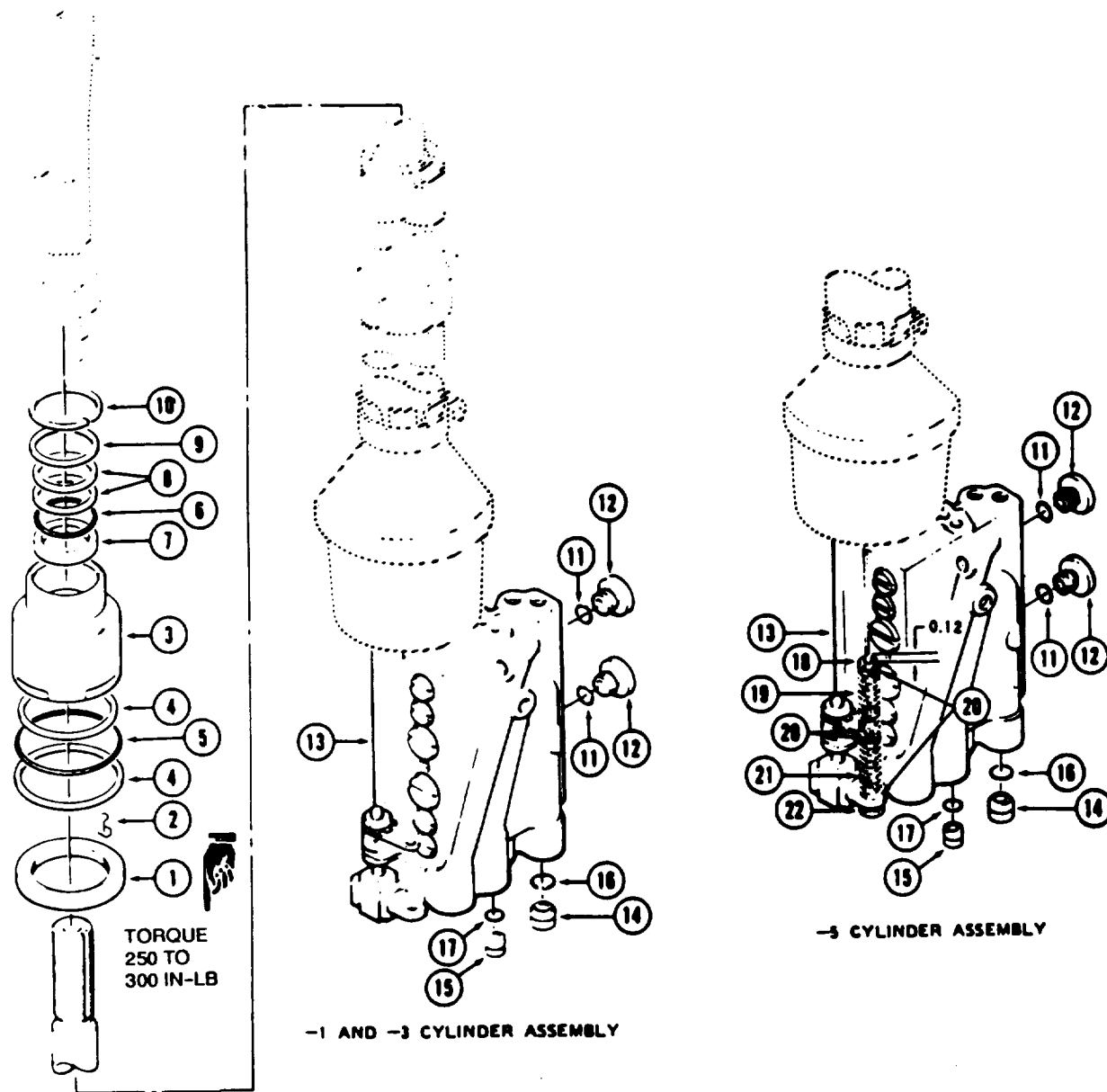

- |                      |                          |                             |
|----------------------|--------------------------|-----------------------------|
| 1. Nut               | 9. Scraper ring retainer | 16. Preformed packing       |
| 2. Lock              | 10. Retain ring          | 17. Preformed packing       |
| 3. Cap               | 11. Preformed packing    | 18. Nut                     |
| 4. Packing retainer  | 12. Bleed plug           | 19. Spring (204-076-399-1)  |
| 5. Preformed packing | 13. Pilot valve          | 20. Washers (4)             |
| 6. Preformed packing | 14. Filter               | 21. Spring (204-07-1-500-1) |
| 7. Packing retainer  | 15. Filter               | 22. Bolt                    |
| 8. Scraper ring      |                          |                             |

204076-1009B

Figure 7-16. Flight Control Hydraulic Cylinder and Servo Actuator Valve

**NOTE**

Assembly dimensions shown on figures 7-12 and 7-15 are nominal and are subject to change during rigging (Chapter 11).

(2) Install rod end (1) into tube (4) until the distance from tube end and hole center of rod end is 2.19 inches. Maintain 2.19 inches distance, torque nut (3) 450 TO 600 inch lbs. Safety nut to safety lock (2) with lockwire (C138). Apply sealant (C105) to exposed threads of rod end bearing (1), jamnut (3), and upper end of control tube.

(3) Install shield assembly (figure 7-15, view B) on housing.

(4) Position lock (24, figure 7-12) into nut (25) and thread nut onto shaft of servo cylinder (23) with lock positioned in keyway on shaft of servo cylinder (23).

**NOTE**

**Assembly dimensions shown on figure 7-12 and 7-15 are nominal and are subject to change during rigging (chapter 11).**

(5) Thread tube (4) onto cylinder piston rod. Adjust centerline of rod end bearing (1) with centerline of head of bolt in servo cylinder lever 56.24 inches (for fore and aft cyclic) or 50.52 inches (for collective) as shown. Torque nut (25) 800 TO 1000 inch-pounds and secure with lockwire (C138).

**NOTE**

Assembly dimensions shown on figures 7-12 and 7-15 are nominal and are subject to change during rigging (chapter 11).

(6) Install clamp (5) on lower end of boot/flange assembly (6) and cylinder (23). Adjust boot/flange assembly (6) 13.70 inches (for fore and aft cyclic) or 8.0 inches (for collective) as shown and install clamp (5) on upper end of boot/flange assembly.

**NOTE**

Ensure aping of larger diameter wire (17, figure 7-12, view C-C) is Installation bottom as illustrated

(7) Install springs (16 and 17) on collective servo cylinder (view C-C) with bolt (18), four washers (19) and nut (20). Thread nut (20) onto bolt (18) until distance from top of nut (20) is 0.12 inch from top of bolt (18, view C-C, figure 7-12).

(8) On the fore and aft cyclic cylinder, keep the 2.19 inch dimension set in step(3) and set rod end bearing to angle shown on figure 7-12, view A-A (FOR FORE AND AFT CYL ASSY). Torque nut (3) 450 TO 600 inch-pounds. Secure nut with lockwire (C138).

(9) On the collective cyclic cylinder, keep the 2.19 inch dimension set in step (3) and set rod end bearing to angle shown in figure 7-12, view A-A (FOR COLLECTIVE CYLASSY). Torque nut (3)450 TO 600 inch-pounds.

(10) Install new packings on fittings and install on servo as shown on figure 7-17, cap or plug open ports to avoid entry of foreign matter.

(11) Remove dual hydraulic cylinder assembly from torque tire (T22 or T23).

b. Lateral Cyclic Dual Hydraulic Cylinder. Assemble lateral cyclic hydraulic cylinder assembly as follows

(1) Place torque fixture (T22 or T23) in suitable vise and install cylinder assembly in fixture (figure 7-13).

**NOTE**

Assembly dimensions shown on figures 7-12 and 7-15 are nominal and are subject to change during rigging (chapter 11).

(2) Install rod end (1) into tube (4) until the distance from tube end and the bolt hole center of rod end is 2.19 inches. Maintain 2.19 inches distance, torque nut (3) 450 TO 600 inch lbs. Safety nut to safety lock (2) with lockwire (C138). Apply sealant (C105) to exposed threads of rod end bearing (1), jamnut (3), and upper end of control tube.

(3) Install spring base (14) at top of cylinder housing.

(4) Place lock (15) into nut (12). Align lock with slot in cylinder piston rod and thread nut (12) on cylinder piston rod.

(5) Position nut (11) and spring (13) on base (14).

(6) Thread lube (4) on cylinder assembly.

**NOTE**

Assembly dimensions shown on figures 7-12 and 7-15 are nominal and are subject to change during rigging (chapter 11).

(7) Adjust tube (4) to 55.16 inch dimension as shown in figure 7-12.

(8) Maintain 55.16 inch dimension and torque nut (12) 8001111000 inch-pounds. Lockwire nut (12) to lock (15) with lockwire (C138).

(9) Position spring (13) and base (14) on cylinder assembly. Threads nut (11) on nut (12). Install nut (11) flush with top of nut (12), as illustrated on figure 7-12, view BB.

(10) Lockwire nut (11) to nut (12) with lockwire (C138).

**(11) Install large boot (6) over spring (13). Seat lower end of boot in groove of base (14).**

(12) Position boot (6) at 15.16 inch dimension as illustrated (figure 7-12).

(13) Install damp (5) to secure upper end of boot (6) to tube (4).

**NOTE**

Assembly dimensions shown on figures 7-12 and 7-15 are nominal and are subject to change during rigging (Chapter 11).

**(14) Keep the 2.19 inch dimension and set rod end bearing to angle shown on figure 7-12, view A-A (FOR LATERAL CYL ASSY). Torque nut (3) 450 TO 600 inch-pounds and secure with lockwire (C138).**

(15) Install new packings on fittings and install fittings in servo as shown on figure 7-17. Cap or plug open to prevent entry of foreign matter.

(16) Remove dual hydraulic cylinder assembly from torque fixture (T22 or T23).

**7-66. P INSTALLATION — DUAL HYDRAULIC CYLINDERS.**

a. Any of three dual hydraulic cylinder assemblies can be installed using the following procedures (figure 7-3). Ensure that dual hydraulic cylinder assembly is correct for control system in which it is to be installed.

**NOTE**

Self-locking nuts will be used one time only in this application.

Rod end bearing (1, figure 7-12) must be positioned in relation to "larger" hole in housing (8) as shown on view A-A, figures 7-12.

Ensure that four washers (26 figure 7-3) are bonded to supports (8 and 18) at each dual hydraulic cylinder installation position.

Bond the washers to the support with adhesive (C8).

b. Carefully lower dual hydraulic cylinder (5, 9, or 17, figure 7-3) down through support (8 or 18). Align "larger" hole in dual hydraulic cylinder housing with "larger" hole in support (8 or 18). Position special washer (25) on MS2006-48, bolt (24) with chamfered side of washer next to bolt head. Install this bolt in larger hole. Hold bolt (24) with work aid shown on figure 7-11. Install washer (27) and nut (28). Install three MS2005-48 bolts (24) in the three "smaller" holes with special washer (25) positioned on bolts in the same manner. Hold bolts with aid shown on figure 7-11. Install washer (27) and nut (28). Torque nuts (28, figure 7-3) evenly to values shown below.

**Nut MS21042L5                      120 TO 160 in-lb**

**Nut MS21042L6                      300 TO 336 in-lb**

Apply slippage index marks with lacquer (C69) or other suitable marking material.

Install lower end of control tube assemblies (13, 52, and 83, figure 11-31) to bellcranks (11, 53, and 85).



Ensure that check valves are installed with flow arrows toward valve in pressure ports P1 and P2. Be sure flow regulators on collective servo cylinder are installed with flow regulator arrow pointing away from servo valve (figure 7-17).

d. Connect hydraulic hoses to fittings in ports at bottom of cylinder valve (19, figure 7-3).



Check that all four bolts through the control valve lever (21, figure 7-3) have a self-locking castellated nut safetied with a cotter pin. Check that nuts and bolts as an assembly can be turned by hand after cotter pin installation (four places).

a. Connect upper rod end bearing of control tube assembly (6, 7, or 22) to control valve lever (21) with bolts, two thin washers, self-locking castellated nut and cotter pin. Hold nut on the blind side with wrench and turn the head of the bolt with wrench until nut slot is in alignment with bolt shank hole for cotter pin installation. Make sure nut and bolt as an assembly can be turned by hand. Install cotter pin.

**NOTE**

Cotter pin is to be installed after final rigging is checked.

f. Position and connect rod end bearing of dual hydraulic cylinder to swashplate horn or collective lever, using attaching parts as shown (figure 7-18). Check rigging of collective and cyclic control system (paragraphs 11-7 and 11-29).

g. Reconnect any hydraulic connections loosened for removal.

**7-67. P INTERSYSTEM LEAKAGE – DUAL HYDRAULIC CYLINDERS.**

Intersystem leakage may occur in one or more dual hydraulic cylinders. If one system reservoir consistently overflow while the other reservoir shows low fluid level, intersystem leakage may be indicated if the amount exceeds limits of note 3, table 7-1. To check for intersystem leakage and to isolate the faulty cylinder(s) proceed as follows:



**Extreme caution should be exercised when accomplishing the following. Damage to helicopter or physical injury to maintenance personnel may result from improper action.**

a. Bleed all residual pressure from system (paragraph 7-3).

b. Trace return lines from the overflowing reservoir to each dual hydraulic cylinder. Mark lines for subsequent removal.

c. Connect hydraulic test stand (S2) hoses to system which shows low fluid level.

d. Disconnect control tube (6, 7, or 22, figure 7-3) from control valve lever (21) of dual hydraulic cylinder being tested. Disconnect rod end of bearing of dual hydraulic cylinder from swashplate horn or collective lever. Disconnect previously located return line from dual hydraulic cylinder (step b above).



**Position dual hydraulic cylinder so that movement of cylinder will not result in damage to swashplate or push-pull tube or injury to maintenance personnel.**

e. Set hydraulic test stand (S2) for approximately 6 gpm flow at 850 TO 900 psig pressure.

f. Extend cylinder to full travel. Leakage from cylinder return port after the cylinder is bottomed indicates intersystem leakage. Increase pressure to 1475 TO 1525 psig and check both open ports.

g. Repeat steps e. and f. with cylinder in full retract position.



k Refill and bleed hydraulic system (paragraphs 7-6 and 7-3).

L Remove maintenance platform (S10) from helicopter.

m. Disconnect hydraulic test stand (S2) from helicopter.

7-68. **P** SERVO VALVE REPLACEMENT - DUAL HYDRAULIC CYLINDERS (AVIM).

With cylinder assembly removed and in a dean, sheltered work area replace servo valve on a dual hydraulic cylinder assembly.

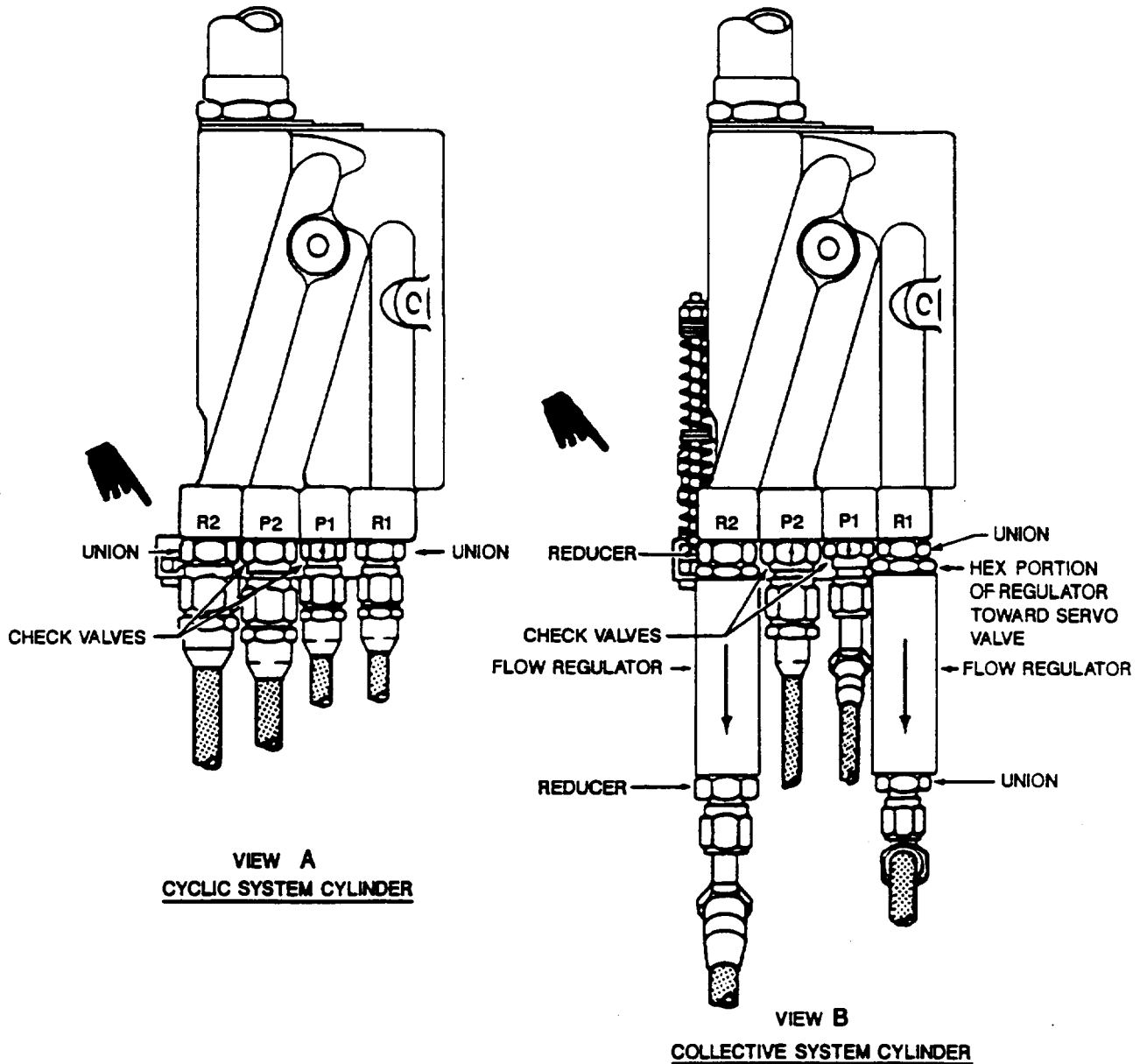
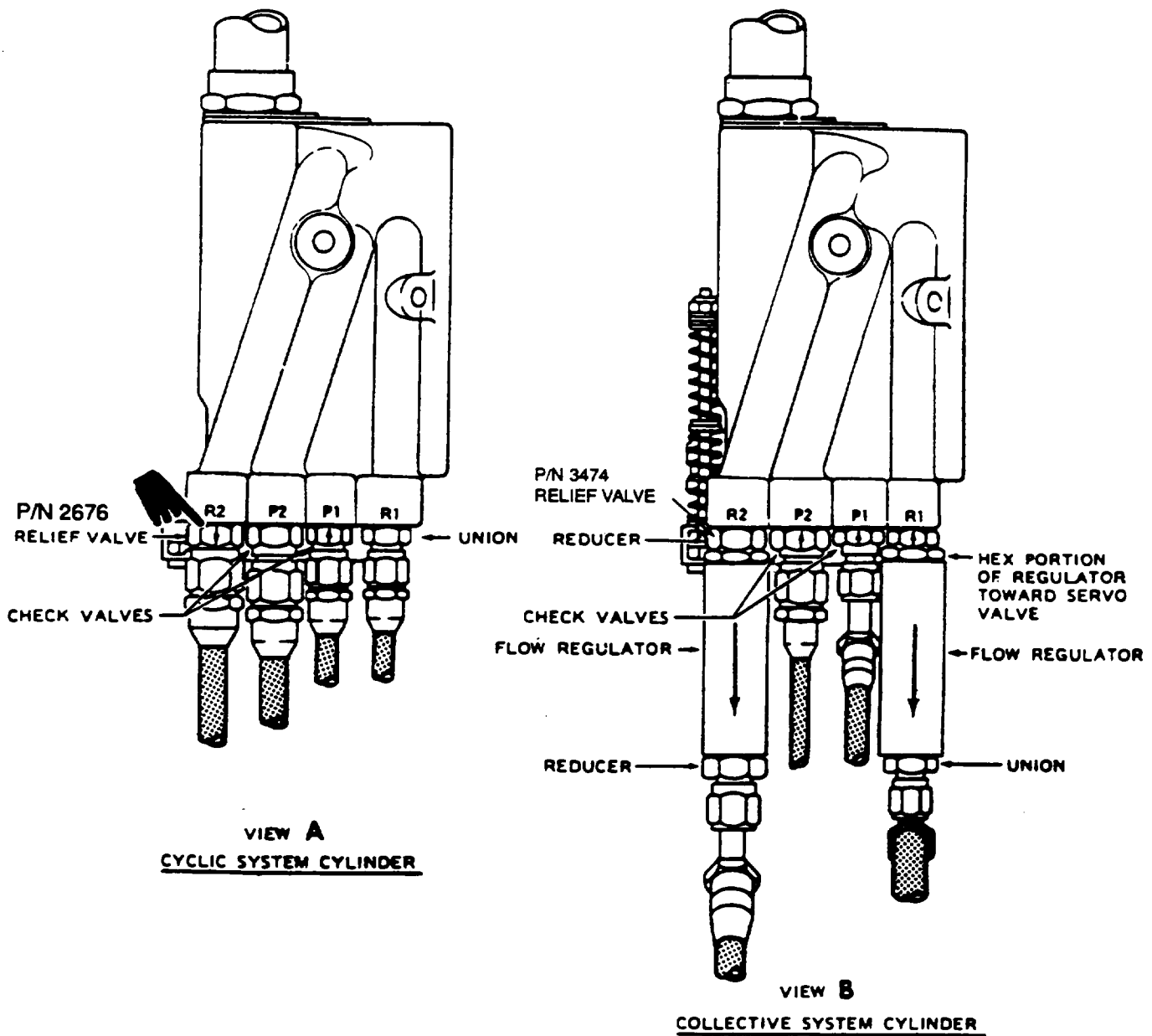

Figure 7-17. **P** Dual Hydraulic Cylinder Valve Connections (Sheet 1 of 2).



209076-24F

Figure 7-17. **E** | Dual Hydraulic Cylinder Valve Connections (Sheet 2 of 2).

7-69. **P** REMOVAL - SERVO VALVE - DUAL HYDRAULIC CYLINDERS.

a. Loosen nut (2, figure 7-19) enough to release tab lockwasher (3) from slot in top of servo valve (5) housing. Unscrew servo valve from piston rod (1).

b. Remove six packings (4) from piston rod (1).

7-70. **P** INSTALLATION - SERVO VALVE - DUAL HYDRAULIC CYLINDERS.

a. With nut (2, figure 7-19) and tab washer (3) in place, install six new packings (4) on piston rod (1). Apply a heavy coat of hydraulic fluid (C61 or C62) to packings (4) and lower end of piston rod (1). Screw servo valve (5) onto threaded end of piston rod (1) until

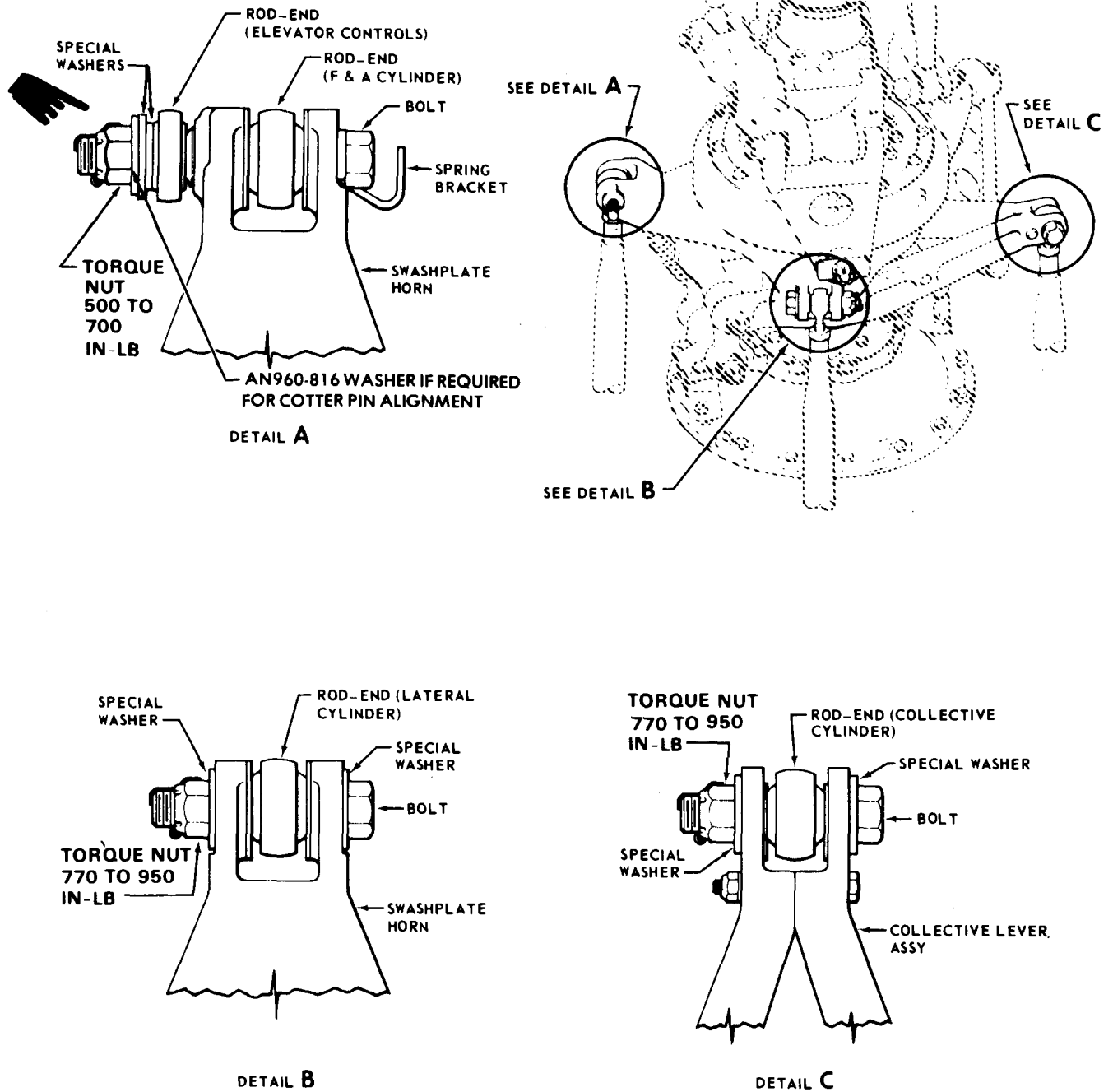

209001-19B

Figure 7-18. Dual Hydraulic Cylinders to Swashplate and Collective Lever Installation

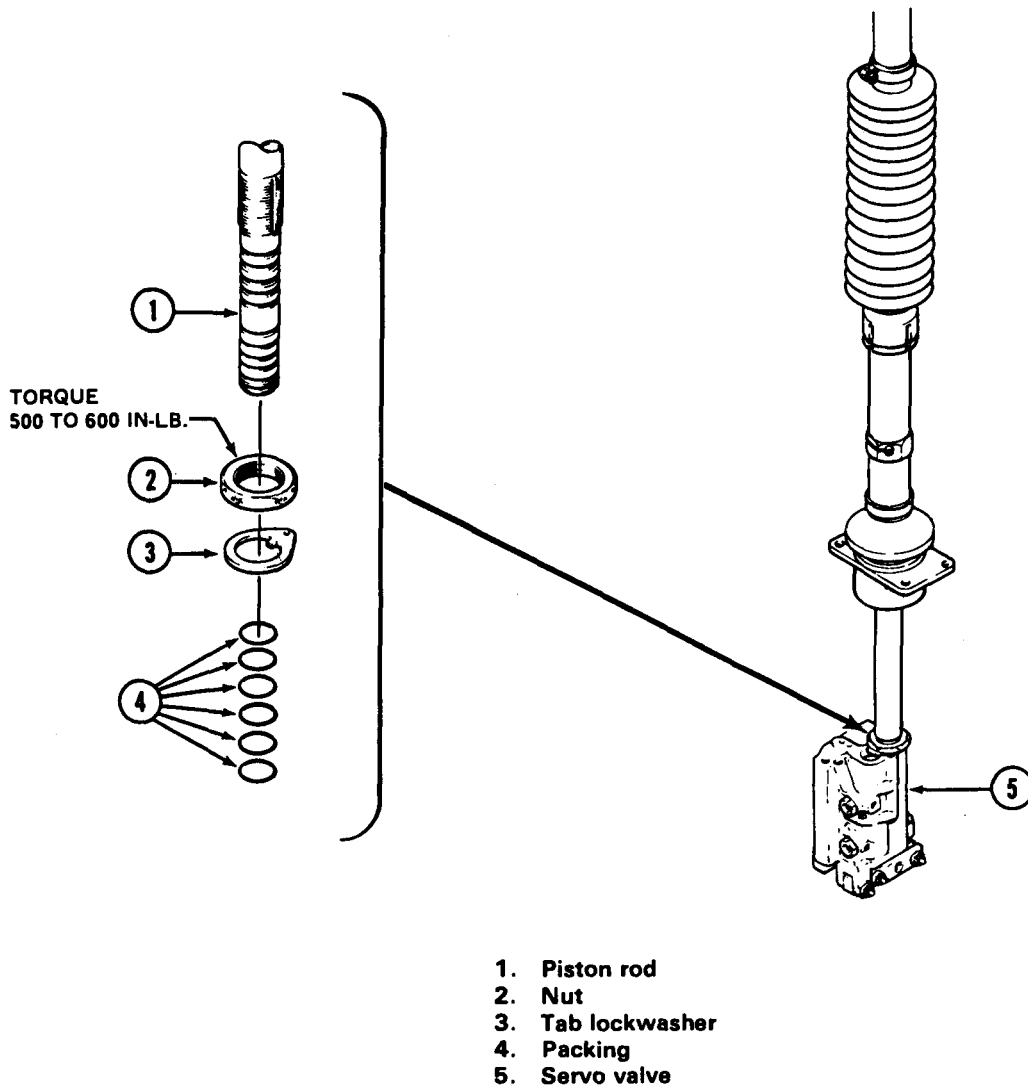

204076-1008A

Figure 7-19. Dual Hydraulic Cylinder Servo Valve Installation

bottomed. Back off servo valve (5) one-half to one and one-half turns to align and insert tab lockwasher (3) into slot at top of servo valve housing. Turn nut (2) down to hold tab lockwasher (3) in slot.

b. Torque nut (2) **500 TO 600** inch-pounds and secure with lockwire (C137).

**CAUTION**

Ensure that check valves are installed with flow arrows toward valve in pressure ports P1 and P2 (figure 7-17).

c. **P** Install check valves, and/or flow regulators, and fittings into ports in lower end of servo valve (5). See figure 7-17.

d. **E M** Install check valves, relief valves; and/or flow regulators and fittings into parts in lower end of servo valve (5), see figure 7-17 (Sheet 2).

7-71. **P** (SCAS) SERVO ACTUATORS.

7-72. **P** DESCRIPTION - (SCAS) SERVO ACTUATORS.

Hydraulic components of stability and control augmentation system (SCAS) are the pitch, roll, and yaw servo actuators (figure 7-1 and 7-20) and

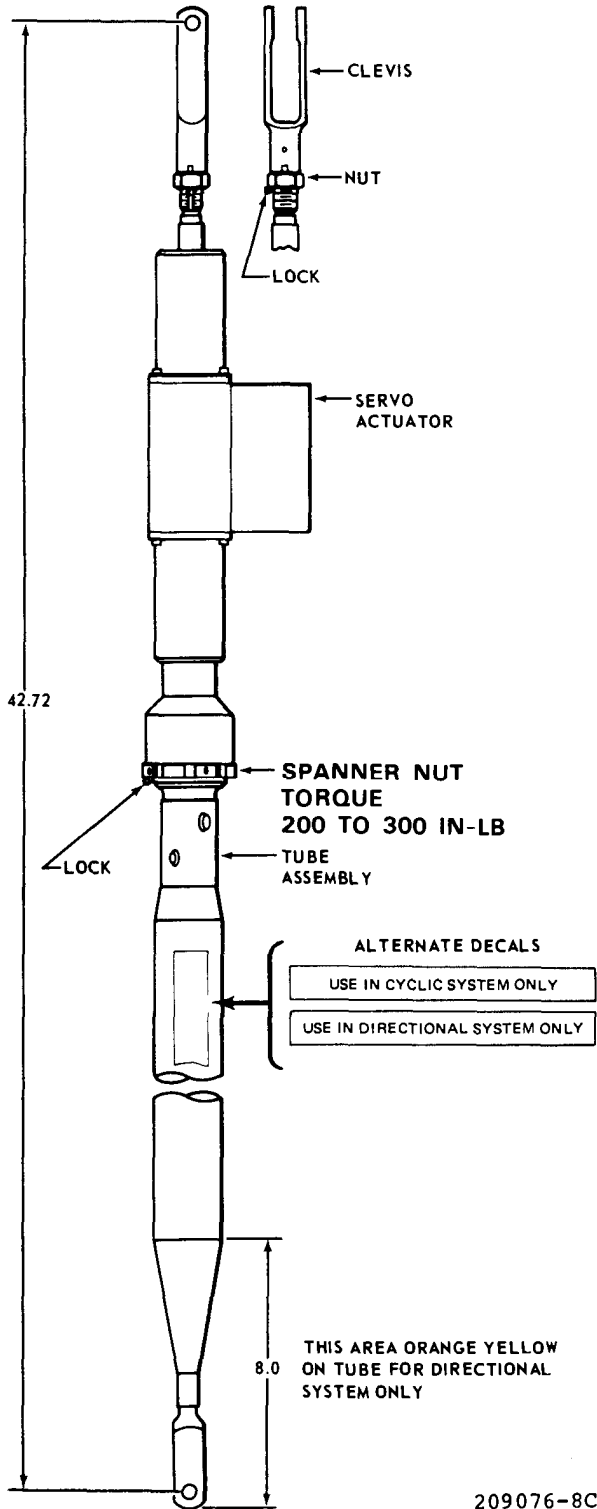

Figure 7-20. (SCAS) Servo Actuator Assembly

associated pressure line filters, solenoid valves, and connecting lines. Each actuator assembly consists of an electro-hydraulic servo actuator, fitted with a tube assembly at one end and a clevis at the other for connection into cyclic and tail rotor control linkages ahead of hydraulic power cylinders. Filters, rated 10 micron, are in pressure lines to protect each actuator. Solenoid valves have two positions, pressure-to-cylinder when electrically energized, or cylinder-to-return when de-energized.

Premaintenance Requirements for (SCAS) Servo Actuators

Condition	Requirements
Model	AH-1S
Part No. or Serial No.	209-076-020-3, -5
Special Tools	None
Test Equipment	None
Support Equipment	None
Minimum Personnel Required	Two
Consumable Materials	(C22) (C61) (C62) (C112) (C127) (C137)
Special Environmental Conditions	None

7-73. **P** REMOVAL - (SCAS) SERVO ACTUATORS.

- a. Remove doors on underside of fuselage for access.
- b. Disconnect electrical connectors and hydraulic hoses from servo actuator. Cap hose and cover ports on actuator.
- c. Remove bolts to disconnect actuator tube and clevis from control system bellcranks. Remove actuator assembly.

**7-74. P CLEANING – (SCAS) SERVO ACTUATORS.**



**Cleaning solvent is flammable and toxic. Provide adequate ventilation. Avoid prolonged breathing of solvent vapors and contact with skin or eyes.**

a. Clean external surfaces, except polished surfaces of piston rod and valve, by wiping with cloth moistened with solvent (C112).

b. Carefully clean polished surfaces of piston rod and valve with a soft cloth moistened with hydraulic fluid (C61 or C62).

**7-75. P INSPECTION – (SCAS) SERVO ACTUATORS.**

a. Inspect tube assembly and clevis for surface damage and corrosion according to limits for flight control tubes (paragraph 11-150).

b. Inspect (SCAS) servo actuator for leakage and corrosion damage.

c. Inspect (SCAS) servo actuator for binding or malfunction.

d. Inspect (SCAS) servo actuator assembly for security.

e. Inspect electrical connector for security.

**7-76. P REPAIR OR REPLACEMENT — (SCAS) SERVO ACTUATORS. (AVIM)**

**NOTE**

**Repair of (SCAS) servo actuator (other than tube replacement) is not permitted. Excessive leakage, damage or malfunction to component requires replacement of part. Damaged part shall be cleaned, wrapped in barrier material (C22) and secured with tape (C127).**

a. Repair surface damage on tube assembly or clevis according to instructions for flight control tubes (paragraph 11-151).

b. Replace tube assembly or clevis if damaged beyond specified limits (paragraph 11-150).



**Do not cross hoses.**

c. Replace servo actuator if malfunction occurs. If both the roll and the pitch actuators must be replaced, remove and install one at a time to avoid possibility of crossing hoses.

d. When replacing (SCAS) servo actuator assembly, remove hydraulic fittings for use on new assembly.

e. When replacing tube assembly, ensure that tube is correct part for control system in which it is to be used. Decals are provided on tubes for this purpose.

(1) Tubes for lateral cyclic and fore-and-aft cyclic systems are identical, and have an internal rod in riveted joint at inboard end.

(2) Tube for directional (tailrotor) control system omits the internal rod because of vibration conditions at its location and is marked by orange yellow paint on outer end.

f. When replacing tube on (SCAS) servo actuator, torque spanner nut **200 TO 300** inch-pounds and secure with lockwire (C137).

g. When replacing clevis on threaded end of (SCAS) servo actuator piston rod, adjust clevis **42.72** inches as shown. Torque nut against clevis and secure nut to lock with lockwire (C137).

**7-77. P INSTALLATION – (SCAS) SERVO ACTUATORS.**

a. Connect (SCAS) servo actuator into control linkage according to instructions for flight control system.



**Ensure that hydraulic hoses do not chafe when flight control system is operated through full travel.**

b. Connect hydraulic hoses to fittings on (SCAS) servo actuator (figure 7-1).

c. Connect electrical connectors to (SCAS) servo actuator.

d. Perform operational check (paragraph 7-3).

**7-78. P (SCAS) FILTER REPLACEMENT.**

**7-79. P DESCRIPTION – (SCAS) FILTER REPLACEMENT.**

One in-line (SCAS) filter is located in the pressure line to the directional (anti-torque) (SCAS) servo actuator, and one in line (SCAS) filter is located in the pressure line to each of the two cyclic (SCAS) servo actuators (figures 7-1, 7-2, and FO-1).

**NOTE**

**Change filter(s) ONLY if (SCAS) servo actuators malfunctions because of restricted hydraulic flow.**

a. Identify the in line filter which is to be replaced. The two in line filters for the cyclic (SCAS) servo actuators are located in the compartment below the transmission. Remove panels on both sides of the fuselage below wings to gain access to the compartment. The in line filter for the directional (anti-torque) (SCAS) servo actuator is located in a compartment in the lower part of the fuselage below the engine. Remove access panel aft of the aft landing gear cross tube to gain entry to the compartment.

b. Before removal of in line filter, note flow direction arrow on filter and decal on adjacent structure. Use standard precautions to prevent spillage of hydraulic fluid and remove filter. If new filter is not to be installed immediately, cap or plug open lines.

c. Install new filter with flow arrow properly oriented. Use new packings.

d. Perform functional check to ensure (SCAS) servo actuator operates properly, and that there are no hydraulic leaks (paragraph 7-3). Install access panels.

**7-80. P CYLINDER AND SUPPORT ASSEMBLY – TAIL ROTOR CONTROL.**

**7-81. P DESCRIPTION – CYLINDER AND SUPPORT ASSEMBLY – TAIL ROTOR CONTROL.**

The hydraulic cylinder and support assembly used in tail rotor control system is mounted horizontally in the fuselage compartment just ahead of the tailboom. Access is by a door attached with cowling fasteners on right side, aft end, of the fuselage. The assembly includes a power cylinder and a walking beam mounted together in a support (figures 7-21 and 7-22). The cylinder is connected by hoses into hydraulic System No. 1.

**Premaintenance Requirements for Cylinder and Support Assembly – Tail Rotor Control**

Condition	Requirements
Model	AH-1S
Part No. or Serial No.	209-001-700-5
Special Tools	None
Test Equipment	None
Support Equipment	None
Minimum Personnel Required	Two
Consumable Materials	(C112) (C120) (C88) (C91) (C61) (C62) (C23) (C127)
Special Environmental Conditions	Clean, dust Free Area

**7-82. P REMOVAL – CYLINDER AND SUPPORT ASSEMBLY – TAIL ROTOR CONTROL.**

a. Remove access panel (12, figure 2-2) and FM sense antenna (35, figure 2-3).

b. Provide a small suitable container to catch spilled fluid when removing hose assemblies (2 and 21, figure 7-21) and tube assembly (16).

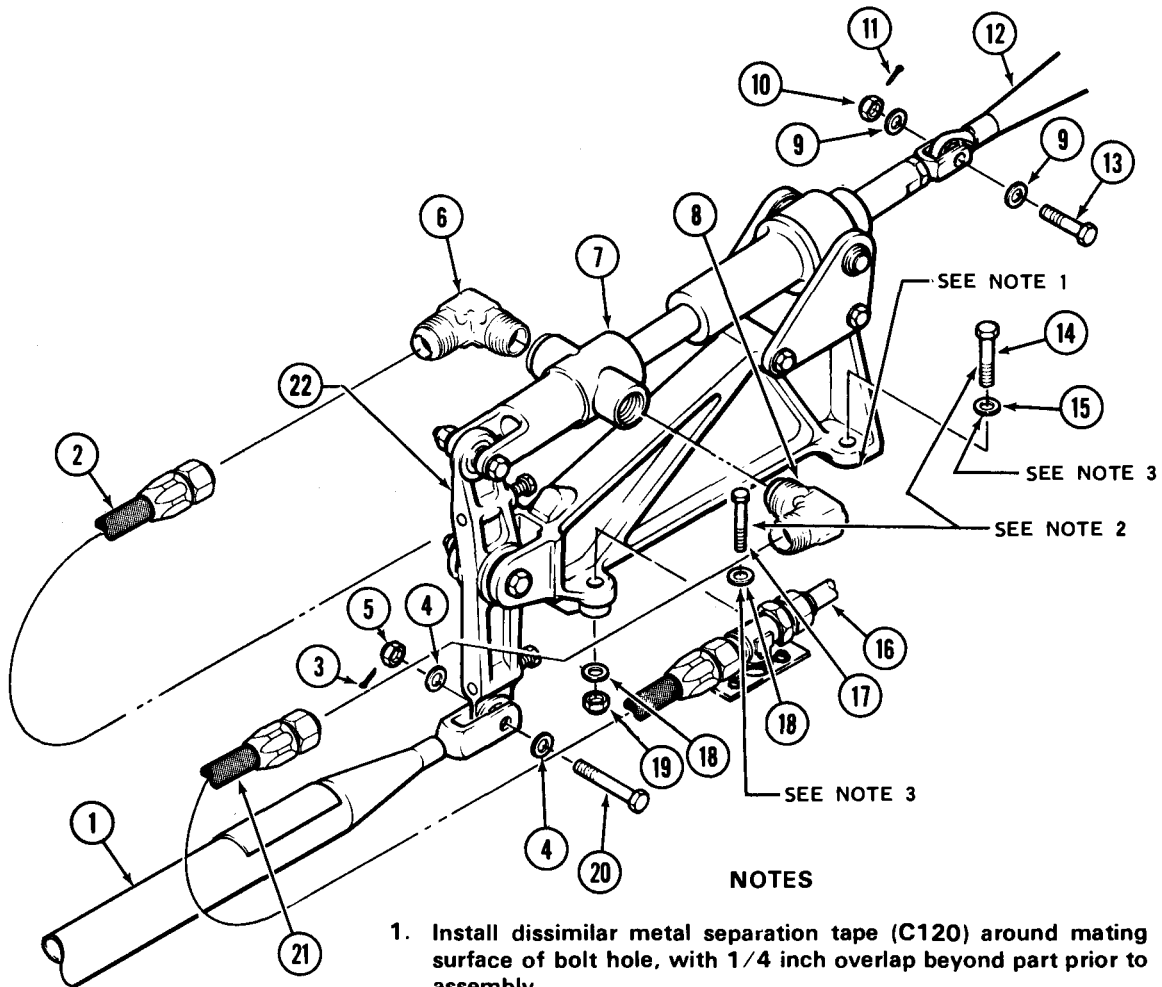

**NOTES**

1. Install dissimilar metal separation tape (C120) around mating surface of bolt hole, with 1/4 inch overlap beyond part prior to assembly.
2. Apply primer (C88 or C91) to bolt prior to installation.
3. Install NAS1197-516 washers adjacent to magnesium only.

- 1. Control tube
- 2. Hose assembly
- 3. Cotter pin
- 4. Washers
- 5. Nut
- 6. Elbow
- 7. Cylinder and support assembly
- 8. Elbow
- 9. Washers
- 10. Nut
- 11. Cotter pin

- 12. Control tube
- 13. Bolt
- 14. Bolt
- 15. Washer
- 16. Tube assembly
- 17. Bolt
- 18. Washers
- 19. Nut
- 20. Bolt
- 21. Hose assembly
- 22. Walking beam

209001-107B

Figure 7-21. Tail Rotor Control Cylinder and Support Installation



**NOTE**

1. Install dissimilar metal separation tape (C120) to bottom of mounting pad, with 1/4 inch overlap beyond part, prior to installation.
2. Apply primer (C88 or C91) to bolt prior to installation.
3. Install NAS1197-516 washers adjacent magnesium only.

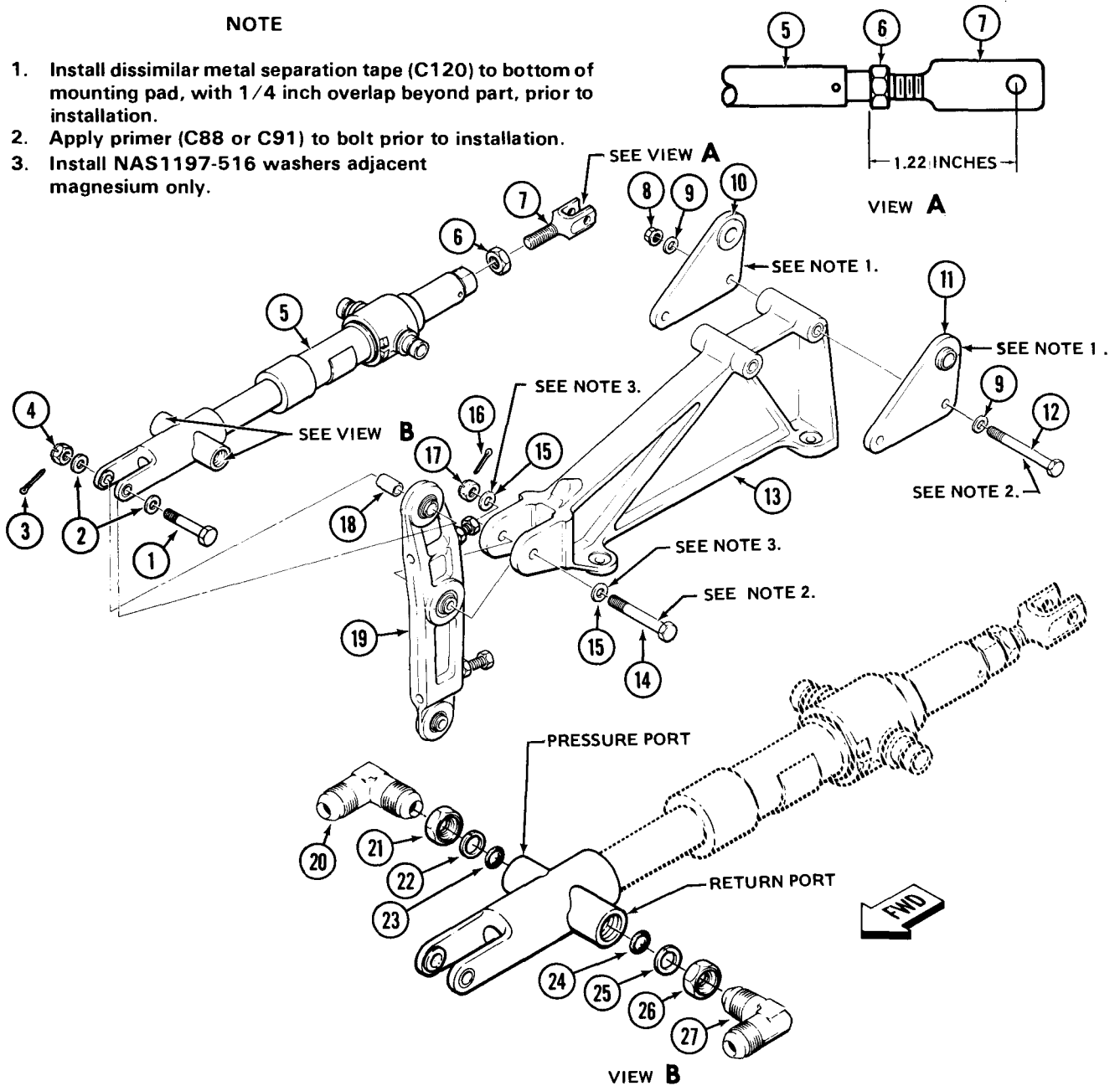

- |                      |                      |                  |
|----------------------|----------------------|------------------|
| 1. Bolt              | 10. Plate assembly   | 19. Walking beam |
| 2. Washers           | 11. Plate assembly   | 20. Elbow        |
| 3. Cotter pin        | 12. Bolt             | 21. Nut          |
| 4. Nut               | 13. Support assembly | 22. Ring         |
| 5. Cylinder assembly | 14. Bolt             | 23. Packing      |
| 6. Nut               | 15. Washers          | 24. Packing      |
| 7. Clevis            | 16. Cotter pin       | 25. Ring         |
| 8. Nut               | 17. Nut              | 26. Nut          |
| 9. Washers           | 18. Spacer           | 27. Elbow        |

209001-108B

Figure 7-22. Tail Rotor Control Cylinder and Support Assembly

c. Remove hose assembly (2) from elbow (6). Install protective dust cover to connector of hose assembly.

d. Remove hose assembly (21) from elbow (8). Install protective dust cover to connector of hose assembly.

e. Remove tube assembly (16). Install protective dust covers to open fittings and tube assembly connectors.

f. Remove cotter pin (11), nut (10), two washers (9), and bolt (13) from clevis of cylinder and support assembly (7) and remove control tube (12) from clevis.

g. Remove cotter pin (3), nut (5), two washers (4) and bolt (20) from control tube (1) and remove control tube from walking beam (22).

h. Remove two nuts (19), four washers (18) and two bolts (17) attaching cylinder and support assembly (7) to floor panel of fuselage.

i. Remove two bolts (14) and two washers (15) attaching cylinder and support assembly (7) to floor panel of fuselage and remove cylinder and support assembly. Cap open ports of elbows (6 and 8).

### 7-83. **P** DISASSEMBLY – CYLINDER AND SUPPORT ASSEMBLY – TAIL ROTOR CONTROL.

a. Provide a clean work area. Remove cotter pin (3, figure 7-22), nut (4), two washers (2) and bolt (1) from cylinder assembly (5) and walking beam (19). Remove spacer (18) from walking beam (19).

b. Break torque on nut (6) and remove clevis (7) from piston rod of cylinder assembly (5). Remove nut (6) from clevis (7).

c. Remove two nuts (8), four washers (9), two bolts (12) and plate assemblies (10 and 11) from cylinder assembly (5) and support assembly (13).

d. Remove cotter pin (16), nut (17), two washers (15) and bolt (14) from support assembly (13) and walking beam (19). Remove walking beam from support assembly.

### 7-84. **P** CLEANING – CYLINDER AND SUPPORT ASSEMBLY – TAIL ROTOR CONTROL.

## WARNING

Cleaning solvent is flammable and toxic. Provide adequate ventilation. Avoid prolonged breathing of solvent vapors and contact with skin or eyes. Eye protection is required when using compressed air.

## CAUTION

To prevent damaging internal components, do not submerge cylinder assembly (5, figure 7-22) or walking beam (19) in solvent. Ensure that PRESSURE and RETURN ports in cylinder assembly (5) are capped prior to cleaning.

a. Wash external surfaces of cylinder and support assembly with clean cloth saturated with solvent (C112). A soft bristle brush may be necessary to loosen hardened deposits.

b. Allow to air dry or blow dry with clean, filtered, compressed air.

### 7-85. **P** INSPECTION – CYLINDER AND SUPPORT ASSEMBLY – TAIL ROTOR CONTROL.

a. Inspect cylinder assembly (5, figure 7-22) for damage, evidence of leaks and freedom of operation of control valve.

b. Inspect support assembly (13) and plate assemblies (10 and 11) for cracks, elongated bolt holes, corrosion damage, and surface damage, such as nicks or scratches. The following limits apply:

(1) Cracks are not acceptable in any part.

(2) Reaction plate teflon-lined bushing radial wear (or egging) limit at contact point with cylinder is **0.003** inch.

(3) Bolt hole elongation not to exceed **0.010** inch.

(4) Maximum depth of reparable damage is **0.060** inch for mechanical damage (nicks or

scratches), and **0.030** inch for corrosion damage. Maximum depth after cleanup for either type damage is **0.060** inch.

(5) No single area of rework shall exceed **3.5** inches in length and **0.5** inch width. Two or more rework areas within **2.0** inches of each other shall be considered as a single area. Total of all rework areas on any one surface must not exceed one-quarter of the surface area.

**7-86. P REPAIR OR REPLACEMENT – CYLINDER AND SUPPORT ASSEMBLY – TAIL ROTOR CONTROL.**

a. Replace defective elbows (20 or 27, figure 7-22) fittings and packings at cylinder PRESSURE or RETURN ports.

b. Replace cylinder assembly (5) if damaged or malfunctioning.



**Do not use high-speed grinding wheels to repair surface damage.**

c. Rework damaged surfaces of support assembly (13) and plate assemblies (10 and 11) by polishing out and blending edges of damaged area into surrounding surface with a smooth contour. Cleanup depth of mechanical damage (nicks, scratches, or dents) need not be greater than depth of damage, provided none of the damage remains. Cleanup depth of corrosion pitting should be at least twice as deep as the deepest pit. Total depth and area of rework shall not exceed limits specified above (paragraph 7-85).

d. Replace any parts that are cracked or where damage is not within repairable limits.

**7-86.1 REPAIR, TAIL ROTOR CONTROL CYLINDER**

Premaintenance Requirements for T/R Control Cylinder P/N1660

Condition	Requirements
Model	AH-1E, F, & P
Special tools	N/A
Test equipment	Hydraulic Test Stand (52)
Consumable materials	(C37) (C61) (C63) (C91) (C112) (C136) (C83.1)

a. Disassembly Procedures.

**NOTE**

**Use a clean working area for disassembly. As parts are removed, place in a clean container for protection against dirt and rough handling. If unit is to remain disassembled for a considerable length of time, protect parts from moisture by immersing in preservative hydraulic fluid.**

(1) Remove cotter pin (3), nut (4), washer (5) and bracket (6). Remove bolt (7) from body (2) (Ref fig. 7-22.1). Slide body (2) off of shaft (23).

**CAUTION**

**Shaft and body assembly (23 and 2, fig. 7-22.1) are select-fit, matched, and precision lapped parts. If either part is damaged, the complete assembly must be replaced as a single unit. Use extreme caution when handling to prevent damage to grooves and adjacent surfaces. Wrap parts after disassembly for protection and retain in set.**

**NOTE**

**if fliter (10) is damaged, remove retaining ring (8), washer (9) and fliter.**

(2) Remove preformed packings (11) from body (2).

(3) Cut lockwire and loosen jam nut (15) from barrel (17) and separate barrel from head (28).

(4) Remove packing (26) from head (28).

(5) Remove shaft (23) and tube assembly (13) from shaft. Remove preformed packings (12 and 14).

(6) Remove cap seal (25) and preformed packing or ring seal (24).

(7) Remove retaining rings (22), washers (21), scraper rings (20), channel seals (19) and preformed packings (18) from both barrel (17) and head (28).

**WARNING**

Drycleaning solvent, P-D-680, used to clean parts is potentially dangerous to personnel and property. Avoid repeated and prolonged skin contact. Do not use near open flame or excessive heat. Flash point of solvent is 100 degrees F to 138 degrees F (38 degrees C to 59 degrees C).

**CAUTION**

Do not drop body (2) or shaft (23) into container of cleaning solvent. Hand hold to prevent damage to precision-machined surfaces.

**NOTE**

Do not remove bushings (1) from body (2), bushings (27) from head (28), or name plate (16) unless replacement is necessary.

**b. Cleaning Procedure.**

(1) Immerse and wash all metallic parts in dry-cleaning solvent, (C112). Pay particular attention to passages and threaded areas. Remove stubborn dirt with a stiff-bristled, nonmetallic brush moistened in solvent.

**WARNING**

Do not direct compressed air against skin.

(2) Dry all parts with dry, compressed air not in excess of 15 psig (1.06 kg/sq cm).

(3) If components are not to be used immediately after cleaning, flush all parts with preservative hydraulic fluid (C63) and place in a plastic bag and dust-free containers.

**c. Inspection Procedure.**

(1) Inspect all surfaces and threaded areas for damage, signs of wear, burrs, cross-threading, scoring, nicks, and/or corrosion. (Refer to table 7-4.1).

**NOTE**

Excessive wear is defined as any obvious deformation or deterioration of parts which may render the unit inoperative. If doubt exists concerning the serviceability of a part, replace the part.

(2) Mating surfaces and grooves on shaft (23, fig. 7-22.1) and body (2) must be smooth and free of

scratches, scoring, feathered edges, and damage from corrosion.

(3) Check identification plate (16) for security of attachment and legibility.

(4) Examine parts for wear to excess of allowable wear limits as specified in Table 7-4.1.

**NOTE**

Wear on shaft (23) is acceptable if chrome plating is not worn through or is chipped. Wear on body (2) is acceptable if cylinder assembly leakage is within limits as specified in final test procedures.

(5) Make visual check, using 10-power glass, of all radii and corners.

**d. Repair Procedure.**

(1) Except for critical surfaces (lapped parts) on body (2, fig. 7-22.1) and shaft (23), polish out minor scoring on nonsealing and nonbearing ferrous parts with crocus cloth, (C37). Use polishing cloth, to polish out minor scoring on aluminum parts. Thoroughly clean any polished parts.

(2) Redate any parts not repairable by minor polishing and any part worn beyond the allowable wear limits specified in table 7-4.1.

**NOTE**

Body (2, fig. 7-22.1) and shaft (23) are precision-matched parts. If either body or shaft requires replacement, replace them as an assembly.

(3) Replace all packings, cotter pin, scraper rings, and retaining rings whenever these parts are removed during disassembly.

**e. Assembly Procedure.**

(1) Lubrication. Lubricate all internal parts at final assembly in hydraulic fluid (C61) and lubricate all preformed packings with technical petrolatum (C83.1) prior to installation.

**WARNING**

Drycleaning solvent, P-D-680, used to clean parts is potentially dangerous to personnel and property. Avoid repeated and prolonged skin contact. Do not use near open flame or excessive heat. Flash point of solvent is 100 degrees F to 138 degrees F (38 degrees C to 59 degrees C).

**Table 7-4.1 Inspection Criteria**

ITEM NUMBER	NOMENCLATURE	INSPECT FOR		
-1	Bushing	ID wear 0.252 inch maximum		
-2	Body	Thread damage Superficial damage and corrosion Cracks and distortion		
-7	Bolt	Damaged threads and corrosion		
-13	Tube	Cracks, distortion, and superficial damage		
-15	Jamnut	Thread damage Crack distortion and superficial damage		
-17	Barrel	Major ID 0.9405 inch max Minor ID 0.6275 inch max Thread damage Cracks, distortion and superficial damage		
-23	Shaft	Thread damage Cracks and distortion		
-27	Bushing	OD 0.498 minimum		
-28	Head	ID 0.6275 maximum Thread damage Cracks, distortion, and superficial damage		

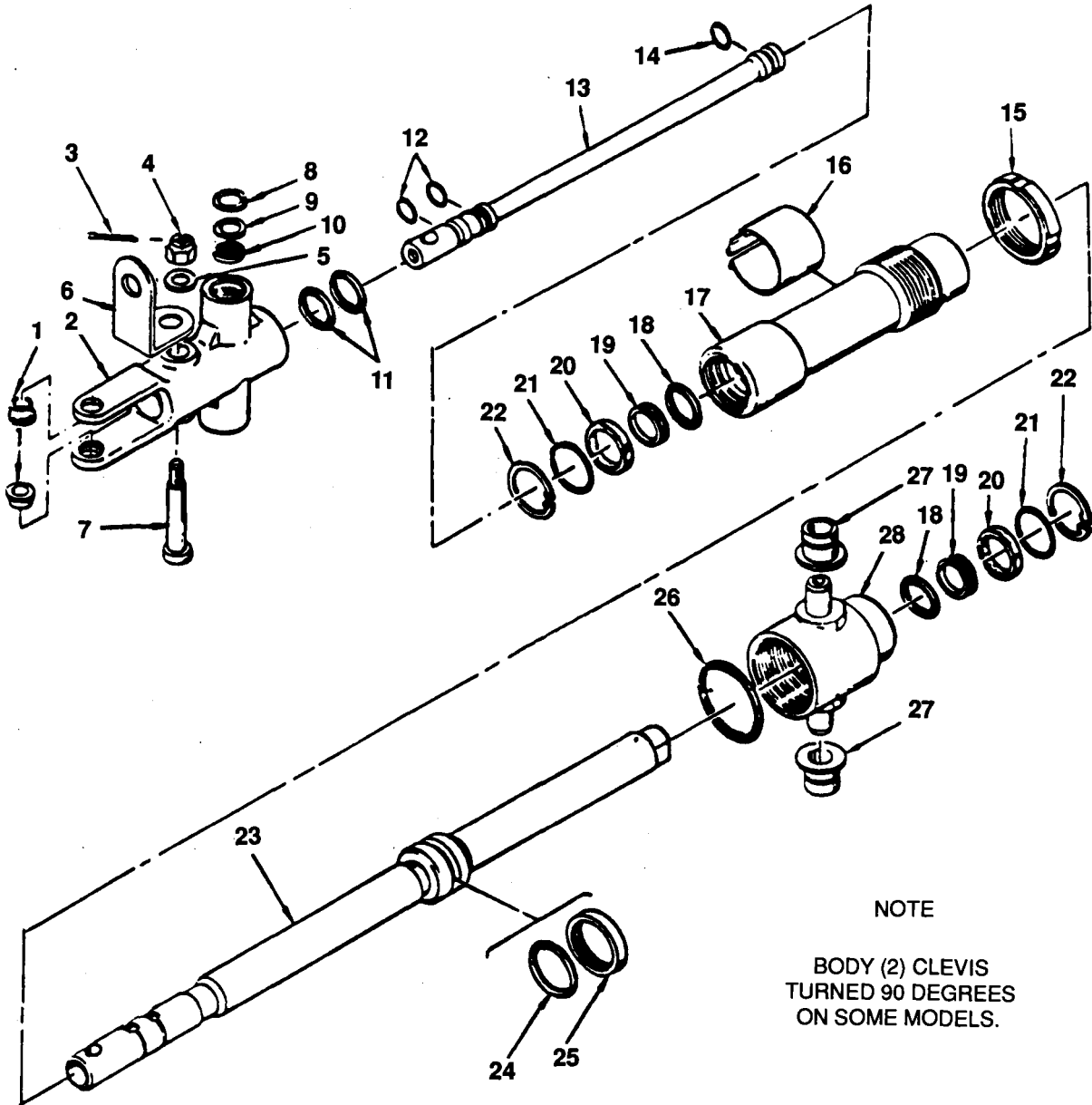

Figure 7-22.1 Hydraulic Servocylinder, Part No. 1660 Series (Typical), Exploded View

**NOTE**

**Coat all internal parts with clean hydraulic fluid (C61), to facilitate reassembly.**

(2) if removed, press new bushings (1, fig. 7-22.1) into body (2) and bushings (27) onto head (28).

(3) When installing packings:

(a) Visually inspect new packings for cuts, nicks or flaws and discard when any evidence of these defects are present.

(b) Ensure that packings are of proper size. Uniform pressure on packings when installed is necessary for satisfactory operation of servocylinder and to prevent leakage.

**NOTE**

**Ensure retaining ring is installed with flat side outboard.**

(c) Install preformed packings (18), channel seals (19), scraper rings (20) and washers (21) and secure with retaining ring (22); in both head (28) and barrel (17).

(d) install preformed packing (26) into head (28).

(e) Assemble ring seal on preformed packing (24) and cap seal (25) onto shaft (23).

(f) Install preformed packings (12 and 14) on tube assembly (13) and insert tube into shaft (23).

**CAUTION**

**Use care when torquing jam nut to preclude damage to barrel (17) and head (28).**

(g) Install barrel (17) and head (28) on shaft (23) and fasten together with jam nut (15). Torque jam nut to **200-250** in-lb. Lockwire after testing.

(h) install preformed packings (11) in body (2) and, if removed, install filter (10), washer (9) and retaining ring (8).

(i) Install body (2) on shaft (23). Insert shoulder bolt (7) through body and shaft and install bracket (6), washer (5), nut (4) and cotter pin (3).

f. Final Performance Check.

(1) Test Procedures.

(a) install cylinder assembly in a suitable hydraulic test stand capable of delivering hydraulic fluid continuously filtered to 10 microns, at pressures up to 2250 psig (158.3 kg/sq cm) at 26.7 degrees C (80 degrees F to 100 degrees F), as test medium. Hydraulic test stand (52).

(b) Bleed all air from cylinder before testing.

(c) Connect PRESS and RET ports to hydraulic pressure source, and apply 2 psig for three minutes. There shall be no external leakage.

(d) Slowly increase pressure to 2250 psig (158.3 kg/sq cm) and hold for three minutes. There shall be no external leakage.

(e) Place servo body in center position and barrel in approximately midposition of travel. Apply 1100 psig (77.4 kg/sq cm) at PRESS port and hold pressure for two minutes. Leakage from RET port must not exceed 60 cubic centimeters per minute.

(f) Apply 1100 psi (77.4 kg/sq cm) at PRESS port and cycle cylinder several times. Position body to actuate barrel to fully extended position. After two minutes in this position, leakage at RET port must not exceed 100 cubic centimeters per minute.

(g) Actuate barrel to fully retracted position, and repeat step f. Same leakage requirements must be met.

(h) With 1500 psi (105.6 kg/sq cm) applied at PRESS port, force necessary to move servo valve body from any position must not exceed 2-1/2 lb (1.135 kg).

(f) Apply 50 psi (9.5 kg/sq cm) to return port for three minutes. If seepage is present, continue test.

**NOTE**

**Combined leakage out of servo valve ends shall not exceed 1 drop in 15 minutes.**

(2) Trouble Analysis. If any malfunction or leakage is observed during tests, refer to table 7-4.2 troubleshooting chart, for probable cause and remedy. Replace parts if required and repeat all test procedures.

g. Post-Test Procedures.

(1) After satisfactory completion of all tests, flush cylinder assembly with preservative hydraulic fluid (C61).

(2) Lockwire jamnut (15), using lockwire (C136).

Table 7-4.2 Troubleshooting Chart

TROUBLE	PROBABLE CAUSE	REMEDY
Leakage during test procedure step e.	Faulty shaft and/or body	Replace shaft (23, fig. 7-22.1) and body (2).
Leakage during test procedure, steps f., and g.	Faulty shaft and/or body	Replace shaft (23) and body (2).
	Tube packings (12) or packing (24) nicked	Replace packings as required.
Leakage from either end of piston	Faulty packings	Replace packings as required.
Excessive force required to move barrel	Shaft in barrel binding	Replace barrel (17) and/or shaft (23) and body (2) and/or head (28).
Valve travel check out of limits	Faulty shaft and/or body	Replace shaft (23, fig. 7-22.1) and body (2) and retest.

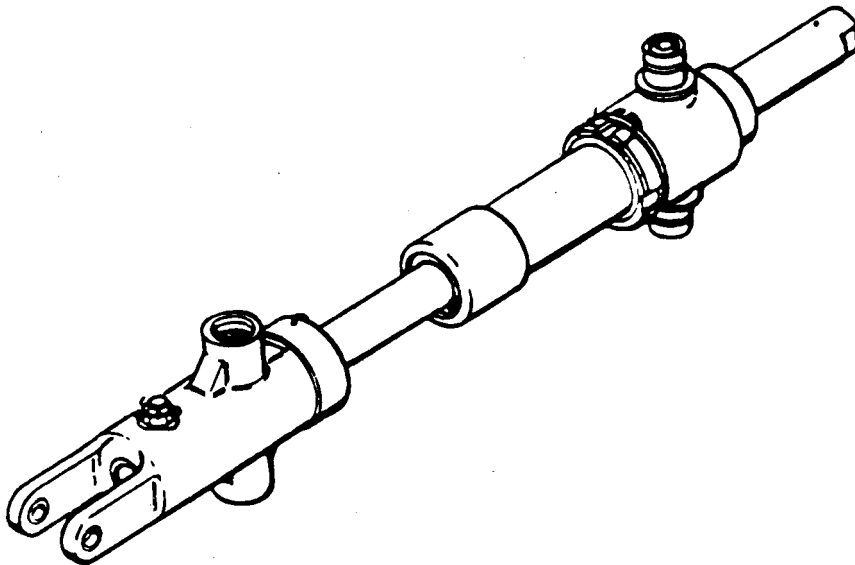

Figure 7-22.2 Hydraulic Servocylinder



Table 7-4.3 Leading Particulars T/R Control Cylinder

Pressure Data:	
Operating	1500 psig (105.6 kg/sq cm)
Proof	2250 psig (158.3 kg/sq cm)
Burst	3750 psig (263.9 kg/sq cm)
Cylinder Stroke	3.500 to 3.540 in. (8.89 to 8.992 cm)
Effective Area	0.38 in. <sup>2</sup> (2.45 sq/cm)
Port Data:	
PRESS	per AND 10050-4 for 1/4 in. tube
RET	per AND 10050-5 for 5/16 in. tube
Servo Valve Data:	
Servo Valve Stroke from Neutral	±0.035 in. (±0.089 cm)
CYL 1 and CYL 2 to RET	0.004 to 0.006 in. (0.010 to 0.015 cm) overlap
PRESS to CYL 1 and CYL 2	0.001 to 0.002 in. (0.003 to 0.005 cm) underlap
Pilot Input Force (after static for 5 minutes and 1500 psi) (105.6 kg/sq cm))	2.5 lb (1.14 kg) (max.)
Hot Load on Valve	1000 lb (454 kg) (max.)
Breakout Force (Ports Open)	5.0 lb (2.27 kg) (max.) (P/N1660-9, -11, -15) 10.0 lb (4.54 kg) (max.) (P/N1660-17, -23)
Overall Dimensions (approx):	
Length	14 in. (35.6 cm)
Width	1.5 in. (3.8 cm)
Height	2.56 in. (6.50 cm)
Weight (Dry)	1.75 lb (max.) (0.79 kg)
Operating Medium	Hydraulic fluid, MIL-H-83282A
Operating Temperature Range	-53.9° C to +82.2° C (-65° F to +180° F)



### 7-87. **P** ASSEMBLY – CYLINDER AND SUPPORT ASSEMBLY – TAIL ROTOR CONTROL.

a. Provide a clean work area and place nut (6, figure 7-22) on clevis (7). Thread clevis into end of cylinder assembly (5) piston rod. Adjust clevis (7) 1.22 inches from end of rod to center of clevis bolt holes (view A), with clevis aligned same direction as valve clevis as shown. Tighten nut (6).

b. Install tape (C120) to inboard surface of plate assembly (10 and 11) bolt holes. Tape must extend 0.25 inch beyond edges of plate assembly.

c. Place plate assemblies (10 and 11) on trunnions of cylinder assembly (5). Position cylinder assembly (5) to support assembly (13). Apply primer (C88 or C91) to two bolts (12) and install bolt with four washers (9) and two nuts (8) through plate assemblies (10 and 11) and support assembly (13).

d. Insert spacer (18) in bearing of walking beam (19). Position cylinder assembly (5) with PRESSURE port at right and align clevis of cylinder assembly on ends of spacer (18). Install bolt (1) with two washers (2) and nut (4). Secure nut (4) with cotter pin (3).

e. Place one washer (15) on bolt (14). Apply primer (C88 or C91) to bolt (14). Position walking beam (19) in clevis of support assembly (13) and install bolt (14), washer (15) and nut (17). Secure nut (17) with cotter pin (16).

f. Install nut (26), ring (25) and packing (24) on elbow (27). Apply a light film of hydraulic fluid (C61 or C62) to threads of elbow (27) and packing (24) and thread elbow in RETURN port of cylinder assembly (5). Position elbow (27) forward as shown in view B and tighten nut (26).

g. Install nut (21), ring (22) and packing (23) on elbow (20). Apply a light film of hydraulic fluid (C61 or C62) to threads of elbow (20) and packing (23) and thread elbow in PRESSURE port of cylinder assembly (5). Position elbow (20) forward as shown in view B and tighten nut (21).

h. If cylinder and support assembly is not immediately being installed, install protective dust caps to open ports of elbows (20 and 27) and wrap with barrier material (C23) and secure with tape (C127).

### 7-88. **P** INSTALLATION – CYLINDER AND SUPPORT ASSEMBLY – TAIL ROTOR CONTROL.

a. Apply tape (C120) to bottom of four mounting pads of cylinder and support assembly (7, figure 7-21). (See NOTE 1 of figure 7-21).

b. Position cylinder and support assembly (7) to floor panel. Place two washers (18) on two bolts (17) and two washers (15) on two bolts (14). Install bolts

(17) through the floor panel and stabilization stop. (Ensure the stop is installed with the flat side toward the rear). Apply a light coat of unreduced primer (C88 or C91) to bolts (14 and 17), and install bolts. Install two washers (18) and two nuts (19) to bolts (17) (lower side of floor panel).

c. Position clevis of control tube (1) to walking beam and install bolts (20), two washers (4) and nut (5). Secure nut (5) with cotter pin (3).

d. Position bearing end of control tube (12) to clevis of cylinder and support assembly (7) and install bolt (13), two washers (9) and nut (10). Secure nut (10) with cotter pin (11).

e. Remove protective dust covers from hydraulic fittings (located on floor panel, inboard and outboard of cylinder and support assembly) and connectors of tube assembly (16). Install tube assembly (16) and torque tube connectors in accordance with torque limits outlined in table 7-4.

f. Remove protective dust covers from elbows (6 and 8) and connectors of hose assemblies (2 and 21). Install hose assemblies (2 and 21) and connectors. Torque connectors in accordance with torque requirements outlined in table 7-4. Check cylinder and support assembly (7) for freedom of movement. Ensure hose assemblies (2 and 21) do not restrict cylinder movement.

g. Move anti-torque pedals through full throw ten times while pressure is on system to eliminate air. operate helicopter engine (refer to TM 55-1520-236-10), or use hydraulic test stand (S2) to pressurize hydraulic system (paragraph 7-3).

#### NOTE

**If air is not eliminated by procedure outlined in step (g), feedback may be experienced during flight. If feedback is experienced, accomplish step (h).**

h. Attach hydraulic test stand (S2) (paragraph 7-3). Disconnect control tube (12) at aft end of power cylinder and control tube (1) at lower end of walking beam (22) (paragraph 7-82, step g). Ensure that cylinder will not strike any structure when actuated. Move walking beam to cause power cylinder to move through full throw ten times. Reinstall control tube (1 and 12). Refer to above steps c and d. Disconnect hydraulic test stand (S2).

#### 7-89. **P** SOLENOID VALVES.

#### 7-90. **P** SOLENOID VALVE P/N 88604-1.

#### 7-91. **P** DESCRIPTION – SOLENOID VALVE P/N 88604-1.

One solenoid valve P/N 88604-1 is located in each hydraulic modular unit (1 and 15, figure 7-1). The solenoid valves are controlled by the HYD TEST switch in the pilot engine control panel.

#### 7-92. **P** CLEANING – SOLENOID VALVE P/N 88604-1.

a. Clean the solenoid valves while installed in hydraulic modular units (1 and 15, figure 7-1).

### WARNING

**Cleaning solvent is flammable and toxic. Provide adequate ventilation. Avoid prolonged breathing of solvent vapors and contact with skin or eyes.**

b. Clean the solenoid valves with a clean cloth moistened with solvent (C112). Use a soft bristle brush to remove stubborn deposits of dirt or oil.

#### 7-93. **P** INSPECTION – SOLENOID VALVE P/N 88604-1.

a. Inspect solenoid valves installed in hydraulic modular units (1 and 15, figure 7-1) for bent or broken pins in electrical connectors.

b. Inspect external surfaces of solenoid valves for nicks, dents, and cracks. No cracks are acceptable.

c. Inspect area around solenoid valves for hydraulic fluid leaks.

#### 7-94. **P** REPAIR OR REPLACEMENT – SOLENOID VALVE P/N 88604-1. (AVIM)

Replace solenoid valve and hydraulic modular units (1 and 15, figure 7-1) as an assembly if solenoid valves fail to meet inspection requirements of paragraph 7-93. Refer to paragraphs 7-39 and 7-43 for removal and installation instructions.

**7-95. P SOLENOID VALVE, P/N 204-076-504-3 FSCM 94641 P/N 1-U-1025-63 or FSCM 16780 P/N 130027-5 (3 and 5, Figure 7-2).**

Two, three-way, two-position solenoid valves (3 and 5) are included in the hydraulic system to permit use of the electric, emergency hydraulic pump in the event of failure of system no. 1 and system no. 2 pumps. The solenoid valves are also used to permit use of the electric, emergency pump during boresighting procedures. The solenoid valves are controlled by the EMER HYDR PUMP/BORESIGHT switch. See FO-1 (foldout 1) for view of hydraulic system schematic. See table 7-5 for leading particulars for solenoid valve P/N 204-076-504-3 FSCM 94641 P/N 1-U-1025-63.

**7-96. P DESCRIPTION – SOLENOID VALVES P/N 204-076-504-3 FSCM 94641 P/N 1-U-1025-63 or FSCM 16780 P/N 130027-5 (3 and 5, Figure 7-2).**

**Table 7-5. Leading Particulars for Solenoid Valve P/N 204-076-504-3 FSCM 94641 (1-U-1025-63)**

---

Operating Medium .....	Hydraulic Fluid, Military Specification MIL-H-5606 (C61) or Military Specification MIL-L-83282 (C62)
Pressures:	
Operating .....	1500 psig
Proof .....	3000 psig
Burst .....	4500 psig
Leakage:	
External .....	none
Internal (at 1500 psig) .....	3 cc per minute maximum with solenoid energized; 1 cc per minute maximum with solenoid de-energized
PE Drop (Port 2 to 1, or 2 to 3):	
At +21 degrees C (+70 degrees F) .....	75 psig (maximum) at 3 gpm flow
At -54 degrees (-65 degrees F) .....	200 psig (maximum) at 3 gpm flow
Solenoid Characteristics:	
Voltage Range .....	18 to 30 volts dc
Current Drain at 28 volts dc and +21 degrees C (+70 degrees F) .....	1.2 amperes (maximum)

**Table 7-5. Leading Particulars for Solenoid Valve  
P/N 204-076-504-3 FSCM 94641 (1-U-1025-63)**

---

Ambient Temperature	
Range: .....	-54 degrees C (-65 degrees F) to +71 degrees C (+160 degrees F)
Weight .....	1.25 pounds

---

**Premaintenance Requirements for  
Hydraulic Solenoid Valves**

Condition	Requirements
Model	AH-1S
Part No. or Serial No.	204-076-504-3
Special Tools	None
Test Equipment	Hydraulic test stand (S2)  Pressure drop test setup (figure 7-27)  Functional test setup (figure 7-27)  30 vdc power supply
Support Equipment	None
Minimum Personnel Required	Two
Consumable Materials	(C22) (C30) (C31) (C36) (C37) (C61) (C62) (C63) (C88) (C91) (C112) (C137)
Special Environmental Conditions	None

**(1)** Remove right fuselage access panel (17, figure 2-3).

**(2)** Disconnect electrical connector from solenoid valve (6, figure 7-23).

**(3)** Provide a suitable container to catch fluid seepage when disconnecting tube assemblies from solenoid valve (6).

**(4)** Remove tube assembly (12) from solenoid valve (6).

**(5)** Disconnect tube assemblies (1 and 10) from solenoid valve (6).

**(6)** Remove two bolts (16) and two washers (15) attaching solenoid valve (6) to bulkhead and remove solenoid valve.

**(7)** Drain hydraulic fluid from solenoid valve (6) and remove fitting (13). Remove packing (14) from fitting (13).

**(8)** Loosen nut (9) and remove elbow (11) from solenoid valve (6). Remove packing (7), ring (backup) (8) and nut (9) from elbow (11).

**(9)** Loosen nut (3) and remove elbow (2) from solenoid valve (6). Remove packing (5), ring (backup) (4) and nut (3) from elbow (2).

**(10)** Install protective dust covers to open ports and electrical connector of solenoid valve (6) to prevent entry of foreign particles.

**b.** Remove solenoid valve (24, figure 7-23) as follows:

**(1)** Remove right fuselage access panel (17, figure 2-3).

**7-97. P REMOVAL – SOLENOID VALVES P/N 204-076-504-3 FSCM 94641 P/N 1-U-1025-63 OR FSCM 16780 P/N 130027-5 (3 AND 5, FIGURE 7-2) AND (6 AND 24, FIGURE 7-23).**

**a.** Remove solenoid valve (6, figure 7-23).

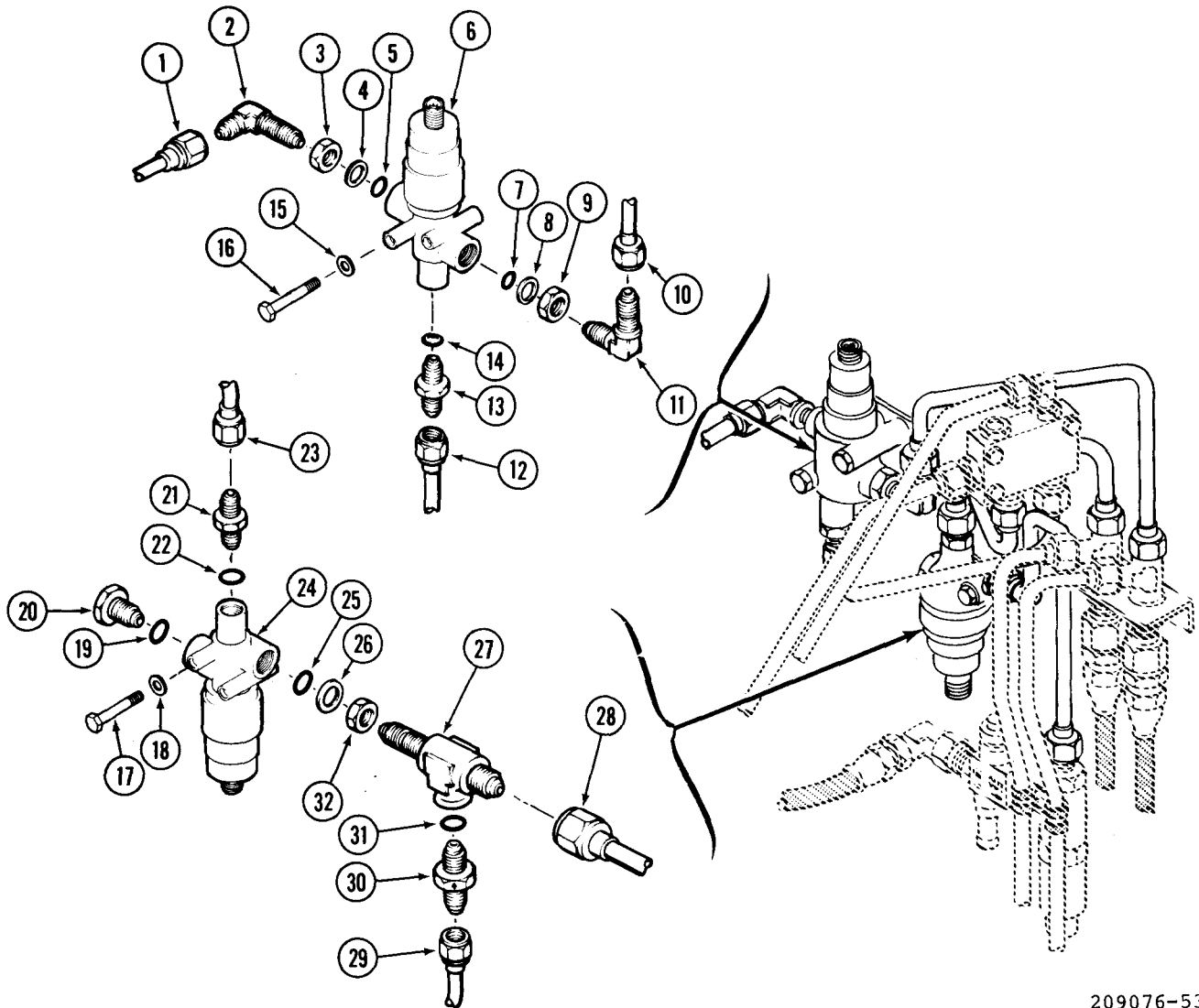

209076-53A

- |  |  |
|--|--|
| <ul style="list-style-type: none"> <li>1. Tube assembly</li> <li>2. Elbow</li> <li>3. Nut</li> <li>4. Ring (backup)</li> <li>5. Packing</li> <li>6. Solenoid valve (P/N 204-076-504-3<br/>FSCM 94641 P/N 1-U-1025-63 or<br/>FSCM 16780 P/N 130027-5)</li> <li>7. Packing</li> <li>8. Ring (backup)</li> <li>9. Nut</li> <li>10. Tube assembly</li> <li>11. Elbow</li> <li>12. Tube assembly</li> <li>13. Fitting</li> <li>14. Packing</li> <li>15. Washers</li> <li>16. Bolts</li> </ul> | <ul style="list-style-type: none"> <li>17. Bolts</li> <li>18. Washers</li> <li>19. Packing</li> <li>20. Plug</li> <li>21. Fitting</li> <li>22. Packing</li> <li>23. Tube assembly</li> <li>24. Solenoid valve (P/N 204-076-504-3<br/>FSCM 94641 P/N 1-U-1025-63 or<br/>FSCM 16780 P/N 130027-5)</li> <li>25. Packing</li> <li>26. Ring (backup)</li> <li>27. Tee</li> <li>28. Tube assembly</li> <li>29. Tube assembly</li> <li>30. Check valve</li> <li>31. Packing</li> <li>32. Nut</li> </ul> |
|--|--|

Figure 7-23. Solenoid Valve P/N 204-076-504-3 Installation

(2) Disconnect electrical connector from solenoid valve (24, figure 7-23).

(3) Provide a suitable container to catch fluid when disconnecting tube assembly (28) from solenoid valve (24).

(4) Remove tube assembly (28) from solenoid valve (24).

(5) Disconnect tube assemblies (23 and 29) from solenoid valve (24).

(6) Remove two bolts (17) and two washers (18) attaching solenoid valve (24) to bulkhead and remove solenoid valve.

(7) Drain hydraulic fluid from solenoid valve (24) and remove fitting (21). Remove packing (22) from fitting (21).

(8) Remove check valve (30) from tee (27) and remove packing (31) from check valve.

(9) Loosen nut (32) and remove tee (27) from solenoid valve (24). Remove packing (25), (backup) ring (26) and nut (32) from tee (27).

(10) Remove plug (20) from solenoid valve (24) and remove packing (19) from plug.

(11) Install protective dust covers to open ports and electrical connector of solenoid valve (24) to prevent entry of foreign particles.

**7-98. P CLEANING – SOLENOID VALVES P/N 204-076-504-3 FSCM 94641 P/N 1-U-1025-63 OR FSCM 16780 P/N 130027-5 (3 AND 5, FIGURE 7-2).**

a. Clean assembled solenoid valves (3 and 5) in same manner outlined in paragraph 7-111.

b. Clean disassembled solenoid valves (3 and 5) FSCM 94641 P/N 1-U-1025-63 as outlined in paragraph 7-102.

**7-99. P INSPECTION – ASSEMBLED SOLENOID VALVES P/N 204-076-504-3 FSCM 94641 P/N 1-U-1025-63 AND FSCM 16780 P/N 130027-5 (3 AND 5, FIGURE 7-2).**

a. Inspect electrical connector for bent or broken pins and damaged threads.

b. Inspect ports for damaged threads.

c. Inspect external surfaces for nicks, dents, and cracks. No cracked parts are acceptable.

**NOTE**

**Inspect disassembled solenoid valve FSCM 94641 P/N 1-U-1025-63 as outlined in paragraph 7-103.**

**7-100. P REPAIR OR REPLACEMENT – SOLENOID VALVES P/N 204-076-504-3 FSCM 94641 P/N 1-U-1025-63 AND FSCM 16780 P/N 130027-5 (AVIM) (3 AND 5, FIGURE 7-2).**

a. Inspect data plate on solenoid valve and determine whether valve is FSCM 94641 P/N 1-U-1025-63 or FSCM 16780 P/N 130027-5.

b. Replace solenoid valves FSCM 16780 P/N 130027-5 that fail to meet inspection requirements of paragraph 7-99.

c. Repair solenoid valves FSCM 94641 P/N 1-U-1025-63 that fail to meet inspection requirements (paragraph 7-104).

**7-101. P DISASSEMBLY – SOLENOID VALVE P/N 204-076-504-3 FSCM 94641 P/N 1-U-1025-63.**

a. Install solenoid valve body (9, figure 7-24) in a smooth-jawed bench vise.

b. Remove lockwire from nut (1).

c. Using a spanner wrench, remove nut (1) from body (9).

d. Remove pin (2), plunger assembly (3), pin (4), pole (5), and coil assembly (17) from body (9).

e. Remove pin (4), pole (5) and plunger assembly (3) from coil assembly (17).



**Keep piston (16) and sleeve (8) together to prevent damage to lapped surfaces. Parts are matched and are not interchangeable.**



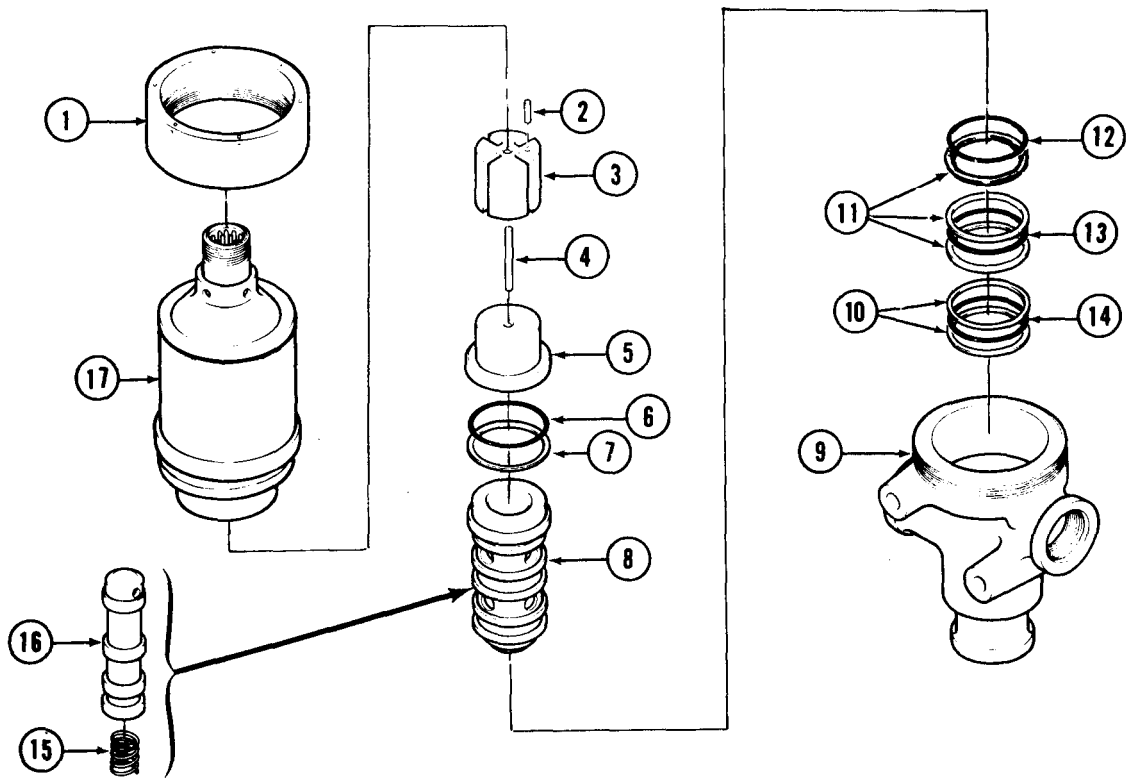

- 1. Nut
- 2. Pin
- 3. Plunger assembly
- 4. Pin
- 5. Pole
- 6. Packing
- 7. Ring (backup)
- 8. Sleeve
- 9. Body

- 10. Rings (backup)
- 11. Rings (backup)
- 12. Packing
- 13. Packing
- 14. Packing
- 15. Spring
- 16. Piston
- 17. Coil assembly

204076-1010A

Figure 7-24. Solenoid Valve P/N 204-076-504-3 FSCM 94641 P/N 1-U-1025-63 Assembly

f. Remove sleeve (8) and piston (16) from bore of body (9) with packings (6, 12, 13 and 14) and backup rings (7, 10, and 11) attached.

g. Remove packings (6, 12, 13 and 14) and (backup) rings (7, 10, and 11) from sleeve (8).

h. Remove spring (15) from bore of body (9).

**NOTE**

Do not remove nameplate and four drive screws from body (9) unless nameplate is damaged.

i. Remove body (9) from bench vise.

**7-102. P CLEANING – DISASSEMBLED SOLENOID VALVE P/N 204-076-504-3 FSCM 94641 P/N 1-U-1025-63.**

**WARNING**

Cleaning solvent is flammable and toxic. Provide adequate ventilation. Avoid prolonged breathing of solvent vapors and contact with skin or eyes. Eye protection is required when using compressed air.

**CAUTION**

Handle detail parts of the solenoid valve carefully to avoid damage.

a. Clean solenoid valve parts with solvent (C112). Use a soft bristle brush to remove stubborn deposits.

b. Allow to air dry or blow dry with clean, filtered, compressed air.

**7-103. P INSPECTION —  
DISASSEMBLED SOLENOID VALVE P/N  
204-076-504-3 FSCM 94641 P/N 1-U-  
1025-63.**

**NOTE**

**The inspection procedures in this paragraph are applicable to disassembled solenoid valve P/N 204-076-504-3 FSCM 94641 P/N 1-U-1025-63.**

a. Inspect all parts for nicks, cracks, scratches, and corrosion. Use a strong light and magnifying glass. No cracked parts are acceptable.

b. Inspect body (9, figure 7-24) and nut (1) for damaged threads.

c. Inspect all packing grooves for surface defects that might cut packings during installation or cause sealing failure during operation.

d. Check security of press fit of pin (2) in plunger assembly (3).

e. Inspect plunger assembly (3) for galling or scoring.

f. Inspect electrical receptacle of coil assembly (17) for broken or bent pins.

g. Inspect sleeve (8) and piston (16) for nicks, scratches, or other visible damage to lapped surfaces.

h. Inspect spring (15) for deformity.

i. Inspect nameplate on body (9) for legibility and security of attachment. Illegible, loosely attached, or missing nameplates are not acceptable.

j. Inspect parts in accordance with table 7-6.

k. Inspect parts in accordance with table 7-7.

**Table 7-6. Non-Destructive Test Requirements for Solenoid Valve  
P/N 204-076-504-3 FSCM 94641 P/N 1-U-1025-63 (AVIM)**

NOMENCLATURE	FIGURE 7-24 INDEX NO.	TYPE OF TEST	PROCEDURE	REMARKS
Nut	1	Magnetic Particle Inspect	Inspect for cracks and strains per MIL-I-6868 and TM 43-0103	If defective, replace with new part.
Piston	16	Magnetic Particle Inspect	Inspect for cracks and strains per MIL-I-6868 and TM 43-0103	If defective, replace with new part.
Sleeve	8	Magnetic Particle Inspect	Inspect for cracks and strains per MIL-I-6868 and TM 43-0103	If defective, replace with new part.

**Table 7-6. Non-Destructive Test Requirements for Solenoid Valve  
P/N 204-076-504-3 FSCM 94641 P/N 1-U-1025-63 (AVIM) (Cont)**

NOMENCLATURE	FIGURE 7-24 INDEX NO.	TYPE OF TEST	PROCEDURE	REMARKS
Body	9	Fluorescent Penetrant Inspect	Inspect for cracks and strains per MIL-I-6866 and TM 43-0103	If defective replace valve.
Spring	15	Dimension and Load	Test Load: 5 to 7 pounds at 0.320 inch	Permanent set shall not result from test load. Spring shall not wobble when rolled across a flat surface.
Coil Assembly	17	Dielectric and Insulation Resistance	Apply 1000 volts ac rms between both receptacle pins and coil assembly case for 10 seconds.	Replace coil assembly if any evidence of dielectric breakdown or leakage. Resistance shall be at least 5 megohms.

**Table 7-7. Diametrical Clearance Requirements for Solenoid Valve  
P/N 204-076-504-3 FSCM 94641 P/N 1-U-1025-63 (AVIM)**

NOMENCLATURE	FIGURE 7-24 INDEX NO.	DIAMETRICAL MAX.	CLEARANCE (IN.) MIN.	REMARKS
Pin	4	0.0100	0.0030	Pin (4) to fit pole (5) center I.D.
Plunger Assembly	3	0.0050	0.0025	Plunger assembly O.D. fit to coil assembly (17) I.D.

**7-104. P REPAIR REPAIR – DISASSEMBLED SOLENOID VALVE P/N 204-076-504-3 FSCM 94641 P/N 1-U-1025-63. (AVIM)**

a. Polish out minor nicks and scratches on metal parts with crocus cloth (C37) (for steel parts) and abrasive cloth (C36) (for aluminum parts), provided that dimensions specified in table 7-7 are maintained, and seating and sealing surfaces are not damaged.

**WARNING**

**The chemical film material is extremely dangerous. Contact with combustible materials will cause explosion or fire. Avoid contact with skin or eyes.**

b. Treat repaired area of anodized finish, after polishing, with chemical film material (C31).

c. If pin (4, figure 7-24) requires replacement, trim end of new pin to provide a stroke of **0.0380 TO 0.0390** inch when pin is installed in pole (5).

d. Replace plunger assembly (3) if pin (2) is damaged or loose, or if plunger assembly shows other visible evidence of damage.

e. Straighten bent pins of electrical receptacle of coil assembly (17). If pins are broken, or if coil assembly is defective, replace coil assembly.

f. Replace packings (6, 12, 13 and 14) and rings (backup) (7, 10 and 11) each time valve is disassembled.

g. If sleeve (8) or piston (16) is defective, replace both parts as an assembly.

h. Replace all worn or damaged parts which cannot be reworked to meet inspection requirements.

i. Replace nameplate on body (9) when damaged, loosely attached, or missing.

**7-105. P ASSEMBLY – SOLENOID VALVE P/N 204-076-504-3 FSCM 94641 P/N 1-U-1025-63.**

a. Apply a light coat of hydraulic fluid (C61 or C62) to all internal parts prior to assembly.

b. Place body (9, figure 7-24) in a smooth jawed bench vise.

c. Install packing (12, 13 and 14) and (backup) rings (11 and 10) on sleeve (8). Carefully slide assembled sleeve in body (9) making certain that packings are not damaged.

d. Insert spring (15) through sleeve (8) into body (9). Carefully slide piston (16) into sleeve (8), making certain that spring (15) is nested in end of piston (16).

e. Install packing (6) and (backup) ring (7) on protruding end of sleeve (8).

f. Carefully slide plunger assembly (3) (with pin (2)) and pole (5) into coil assembly (17). Insert pin (4) in center hole of pole (5).

g. Slide assembled parts (2 through 5) and (17) over protruding end of sleeve (8).

h. Slide nut (1) over end of coil assembly (17) and thread to body (9).

i. Using a spanner wrench, tighten nut (1).

j. If solenoid valve is not immediately being installed on helicopter and will require storage, fill solenoid valve with preservative hydraulic fluid (C63).

**7-106. P TESTING — SOLENOID VALVE P/N 204-076-504-3 FSCM 94641 P/N 1-U-1025-63 (AVIM).**

a. Inspect hydraulic test stand (S2) to ensure that it meets the following requirements:

(1) Capable of providing pressures to **2300** psig at flow rate of 3 gpm.

(2) Equipped for filtration of particles to **10** microns in size;

(3) Serviced with clean hydraulic fluid (C61 or C62).

(4) Capable of maintaining hydraulic fluid within a temperature range of **+21** degrees C (**+70** degrees F) to **+43** degrees C (**+110** degrees F).

b. Refer to table 7-8 if trouble is encountered during procedures in steps c through g.

**Table 7-8. Troubleshooting During Testing of Solenoid Valve  
P/N 204-076-504-3 FSCM 94641 P/N 1-U-1025-63 (AVIM)**

---

## CONDITION

## TEST OR INSPECTION

**CORRECTIVE ACTION**

1. Solenoid valve does not operate smoothly and without hesitation.

STEP 1. Defective coil assembly (17, figure 7-24).

**Replace coil assembly (17). Refer to paragraphs 7-97 through 7-107.**

STEP 2. Pin (4) worn.

**Replace pin (4). Refer to paragraph 7-104.**

STEP 3. Defective plunger assembly (3).

**Replace plunger assembly (3). Refer to paragraph 7-105.**

STEP 4. Defective sleeve (8) or piston (16).

**Damage to either sleeve (8) or piston (16) requires that both parts be replaced as an assembly. Refer to paragraph 7-105.**

STEP 5. Defective spring (15).

2. External leakage.

STEP 1. Packing (6) damaged or incorrectly installed.

**Replace or reinstall packing (6). Refer to paragraph 7-105.**

3. Internal leakage not within limits specified.

STEP 1. Defective sleeve (8) or piston (16).

**Damage to either sleeve (8) or piston (16) requires that both parts be replaced as an assembly. Refer to paragraph 7-105.**

STEP 2. Defective spring (15).

**Replace spring (15). Refer to paragraph 7-105.**

STEP 3. Packings (12, 13 or 14) damaged or incorrectly installed.

**Replace or reinstall packings (12, 13 or 14). Refer to paragraph 7-105.**

---

**c. Break-in Run Test.** Install solenoid valve in a test setup similar to that shown in figure 7-25 and perform the following tests:

(1) Check solenoid valve to ensure flow is as shown on figure 7-26 with the solenoid valve energized and de-energized.

(2) Energize solenoid valve with **28** volts dc.

(3) Adjust regulator valve until a fluid pressure of **1500** psig is indicated on gage A.

(4) Cycle solenoid valve under test 100 times by alternately de-energizing and energizing solenoid. If the solenoid valve does not operate smoothly on each cycle, disassemble and determine cause.

**d. Proof Pressure Test.** With solenoid valve still installed in a test setup similar to that shown in figure 7-25, perform the following tests:

(1) Adjust regulator valve to apply **2250** psig fluid pressure at port 3. Maintain pressure for **2** minutes; there must be no evidence of external leakage or visible distortion of valve.

(2) Repeat preceding step (1) with **5** psig pressure applied at port 3.

(3) Connect pressure source to port 1 and repeat procedures of steps (1) and (2).

(4) After completion of proof pressure test, reconnect pressure to port 3.

**e. Internal Leakage Test.** With solenoid valve still installed in a test setup similar to that shown in figure 7-25, perform the following tests:

(1) Adjust pressure regulator to apply **1500** psig fluid pressure at port 3. Internal leakage from port 1, after a **2** minute waiting period, not to exceed **1** cubic centimeters per minute.

(2) With **1500** psig pressure still applied at port 3, energize solenoid with **18** volts dc. Internal leakage from port 1, after a **2** minute waiting period, not to exceed **3** cubic centimeters per minute.

**f. Operating Voltage Test.** With solenoid valve still installed in a test setup similar to that shown in figure 7-25, perform the following tests:

(1) Adjust pressure regulator to apply **1500** psig fluid pressure at port 3.

(2) Energize solenoid valve with **18** volts dc; then de-energize solenoid valve. Valve operation, as indicated by gage B, shall be instantaneous with no evidence of sluggishness.

(3) Reduce pressure applied at port 3 to **200** psig. Repeat tests described in preceding step (2).

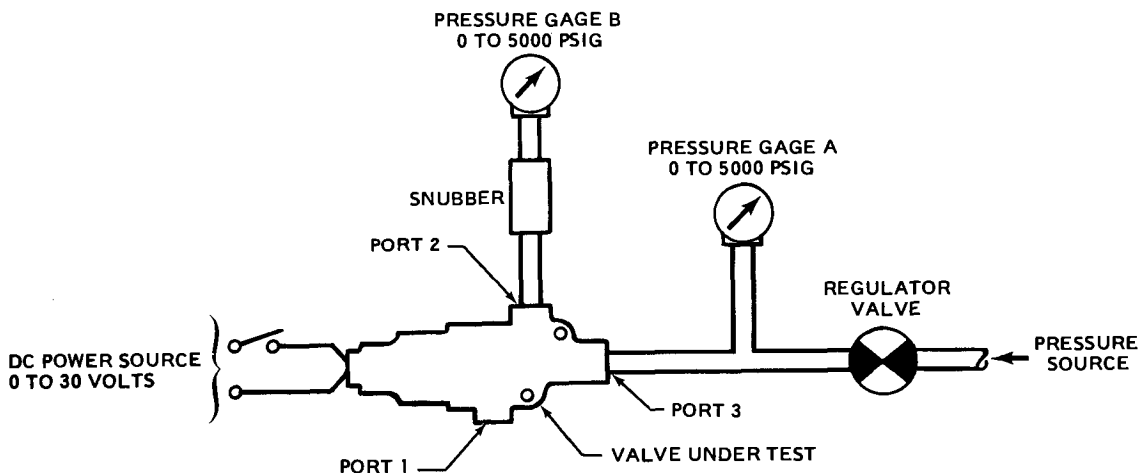

204076-1013

**Figure 7-25. Functional Test Setup for Solenoid Valve  
P/N 204-076-504-3 FSCM 94641 P/N 1-U-1025-63**

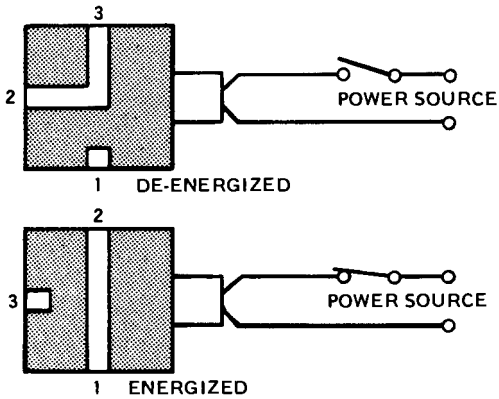

204076-1012

**Figure 7-26. Flow Diagram for Solenoid Valve  
P/N 204-076-504-3 FSCM 94641  
P/N 1-U-1025-63**

(4) Increase pressure applied at port 3 to **2250** psig. Repeat procedure described in preceding step (b), except energize solenoid valve with **28 volts Vdc**.

**g. Pressure Drop Test.** Install solenoid valve in a test setup similar to that shown in figure 7-27 and perform the following tests:

(1) Adjust pressure regulator to gradually apply pressure at port 3 until a flow rate of three gpm is obtained at port 2. Maximum acceptable pressure required to establish three gpm flow is **75 psig** plus "tare". Record pressure required to obtain three gpm flow.

(2) Connect flowmeter to port 1, cap port 3, and connect pressure source to port 2.

(3) Energize solenoid valve with **18 volt dc**.

(4) Adjust pressure regulator to gradually apply pressure at port 2 until a flow rate of three gpm is obtained at port 1. Maximum acceptable pressure required to establish three gpm flow rate is **75 psig** plus "tare". Record pressure required to obtain three gpm flow.

(5) Remove solenoid valve and install a piece of four inch long tubing with **0.375** inch outside diameter and **0.041** inch maximum wall thickness. Use identical fittings to those used in steps (1) through (4). Adjust pressure regulator to gradually apply pressure until a flow rate of three gpm is obtained. Pressure required to obtain a three gpm flow rate is "tare". Record this "tare" figure.

(6) Subtract "tare" figure from pressure recorded in step (1). If result is in excess of **75 psig**, the solenoid valve is unsatisfactory.

(7) Subtract "tare" figure from pressure recorded in step (4). If result is in excess of **75 psig**, the solenoid valve is unsatisfactory.

**7-107. P INSTALLATION – SOLENOID VALVES P/N 204-076-504-3 FSCM 94641 P/N 1-U-1025-63 or FSCM 16780 P/N 130027-5 (3 and 5, figure 7-2).**

a. Install solenoid valve (6, figure 7-23) as follows:

(1) Remove protective dust covers from solenoid valve (6) and drain preservative hydraulic fluid from solenoid valve. Flush solenoid valve with clean hydraulic fluid (C61 or C62).

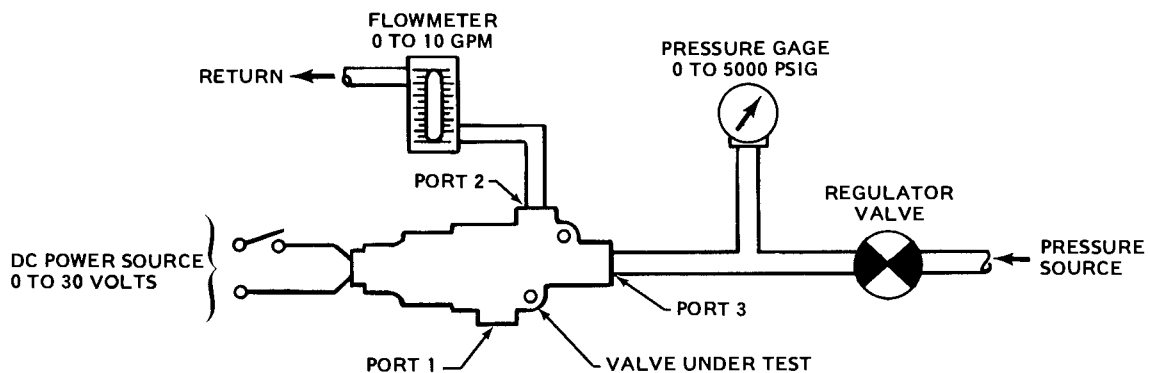

204076-1014

**Figure 7-27. Pressure Drop Test Setup for Solenoid Valve P/N 204-076-504-3 FSCM 94641 P/N 1-U-1025-63**

(2) Apply a light film of hydraulic fluid (C61 or C62) to all packings, threads and tube connectors prior to assembly of part, with the exception of bolts (16).

(3) Install nut (3), backup ring (4) and packing (5) on elbow (2). Thread elbow into PORT 1, of solenoid valve (6), position as shown and tighten nut (3).

(4) Install nut (9), backup ring (8) and packing (7) on elbow (11). Thread elbow into PORT 2 of solenoid valve (6) and tighten nut (9).

(5) Install packing (14) on fitting (13) and install fitting into PORT 3.

(6) Buff mounting pads of solenoid valve (6) to ensure good electrical bond. Position solenoid valve on bulkhead as shown and install two bolts (16) and two washers (15).

(7) Connect and torque tube assemblies (1 and 10) in accordance with table 7-4.

(8) Install tube assembly (12) and torque connectors of tube assembly in accordance with table 7-4.

(9) Install electrical connector to solenoid valve and secure with lockwire (C137).

(10) Fill reservoir to proper level. (Refer to paragraph 7-6.)

(11) Perform operational check of hydraulic system. (Refer to paragraph 7-3.) Refill reservoir.

(12) Install right access panel to fuselage, under wing.

b. Install solenoid valve (24, figure 7-23) as follows:

(1) Remove protective dust covers from solenoid valve (24) and drain preservative hydraulic fluid from solenoid valve. Flush solenoid valve with clean hydraulic fluid (C61 or C62).

(2) Apply a light film of hydraulic fluid (C61 or C62) to all packings, threads and tube connectors prior to assembly of part, with the exception of bolts (17).

(3) Install nut (32), backup ring (26), and packing (25) on tee (27).

(4) Install packing (31) on check valve (30) and install check valve into tee (27).

(5) Thread tee (27) into PORT 2, position tee as shown and tighten nut (32).

(6) Install packing (19) on plug (20) and install plug into PORT 1 of solenoid valve (24).

(7) Install packing (22) on fitting (21) and install fitting into PORT 3 of solenoid valve.

(8) Remove protective dust covers from tube assemblies (23, 28 and 29).

(9) Buff mounting pads of solenoid valve to ensure good electrical bond. Position solenoid valve to bulkhead as shown and install two bolts (17) and two washers (18).

(10) Connect torque tube assemblies (23 and 29) in accordance with table 7-4.

(11) Install tube assembly (28) and torque connectors of tube assembly in accordance with table 7-4.

(12) Install electrical connector to solenoid valve and secure with lockwire (C137).

(13) Fill reservoir to proper level. (Refer to paragraph 7-6.)

(14) Perform operational check of hydraulic system. (Refer to paragraph 7-3.) Refill reservoir.

(15) Install right access panel to fuselage, below wing.

**7-108. P SOLENOID VALVES P/N 209-076-023-1 FSCM 16780 P/N 15353 (7, 9, and 19, figure 7-1).**

**7-109. P DESCRIPTION – SOLENOID VALVES P/N 209-076-023-1 FSCM 16780 P/N 15353 (7, 9, and 19, figure 7-1). 7-1).**

Three, three-way, two-position solenoid valves (7, 9 and 19) are included in the hydraulic system to permit shutting off fluid circulation to any one of the three (SCAS) servo actuators. The solenoid valves are



controlled by the pitch, roll, and yaw switches on the pilot (SCAS) control panel, see FO-1 (foldout 1) for view of hydraulic system schematic.

**Premaintenance Requirements For Hydraulic Solenoid Valves**

Condition	Requirements
Model	AH-1S
Part No. or Serial No.	209-076-023-1
Special Tools	None
Test Equipment	None
Support Equipment	None
Minimum Personnel Required	Two
Consumable Materials	(C112) (C61) (C62)
Special Environmental Conditions	None

**7-110. P REMOVAL – SOLENOID VALVES P/N 209-076-023-1 FSCM 16780 P/N 15353 (7, 9, and 19, figure 7-1).**

a. Remove solenoid valve (16, figure 7-28) for fore and aft (SCAS) system as follows:

- (1) Remove right access panel (17, figure 2-3).
- (2) Disconnect electrical connector from solenoid valve (16, figure 7-28).
- (3) Provide a suitable container to catch fluid seepage when disconnecting tube assemblies from solenoid valve (16).
- (4) Disconnect tube assemblies (1, 2, 8, 19 and 30) from solenoid valve (16).
- (5) Remove two nuts (15), two washers (14), two washers (7), two bolts (6), and remove solenoid (16) from bracket (24).
- (6) Install protective dust covers to open connectors of tube assemblies (1, 2, 8, 19 and 30).

(7) Remove components from solenoid valve (16) as follows:

- (a) Remove fitting (13) from solenoid valve (16).
- (b) Remove fittings (9 and 13) from filter (11) and discard two packings (12) and packing (10). If filter (11) is not immediately being installed, install protective dust covers to open ports.
- (c) Loosen nut (21) and remove elbow (20) from solenoid valve (16). Remove packing (23), (backup) ring (22) and nut (21) from elbow (20) and discard packing (23) and (backup) ring (22).
- (d) Remove fittings (3, 31, and 33) from tee (5) and discard packings (4, 32 and 29).
- (e) Loosen nut (27) and remove fitting (28), with tee (5), from solenoid valve (16).
- (f) Remove packing (25), (backup) ring (26), and nut (27) from fitting (28). Discard packing (25) and (backup) ring (26).
- (g) Remove fitting (28) from tee (5) and discard packing (29).

b. Remove solenoid valve (42, figure 7-28) for lateral (SCAS) system as follows:

- (1) Remove right access panel (17, figure 2-3).
- (2) Disconnect electrical connector from solenoid valve (42, figure 7-28).
- (3) Provide a suitable container to catch fluid seepage when disconnecting tube assemblies from solenoid valve (42).
- (4) Disconnect tube assemblies (34, 37, and 48) from solenoid valve (42).
- (5) Remove two nuts (51), two washers (52), two washers (41), two bolts (40) and remove solenoid valve (42) from bracket (53).
- (6) Install protective dust covers to open connectors of tube assemblies (34, 37, and 48).
- (7) Remove components from solenoid valve (42) as follows:
  - (a) Remove fitting (36) from solenoid valve (42) and discard two packings (35).

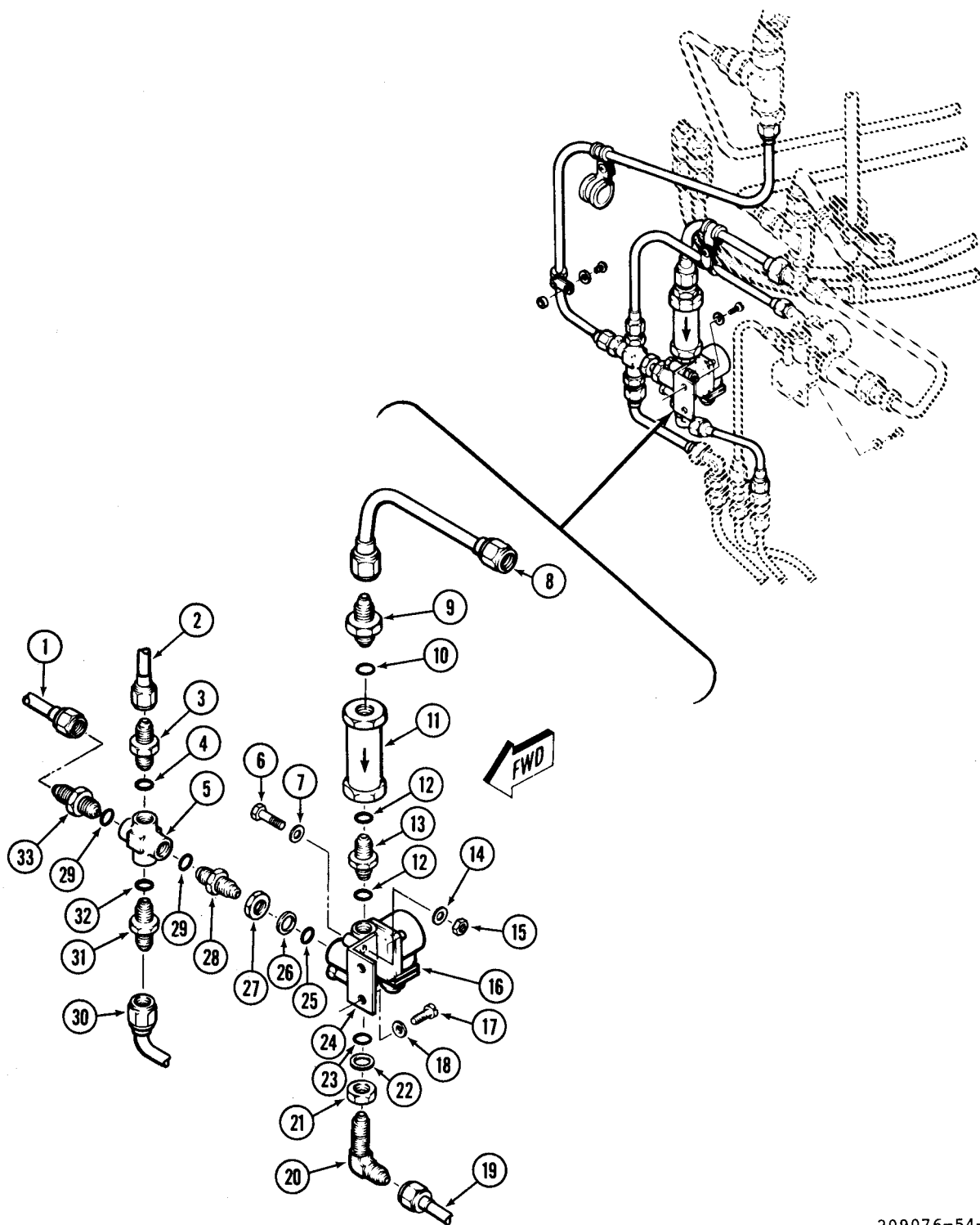

209076-54-1

Figure 7-28. Solenoid Valves (SCAS System) — Installation (Sheet 1 of 4)

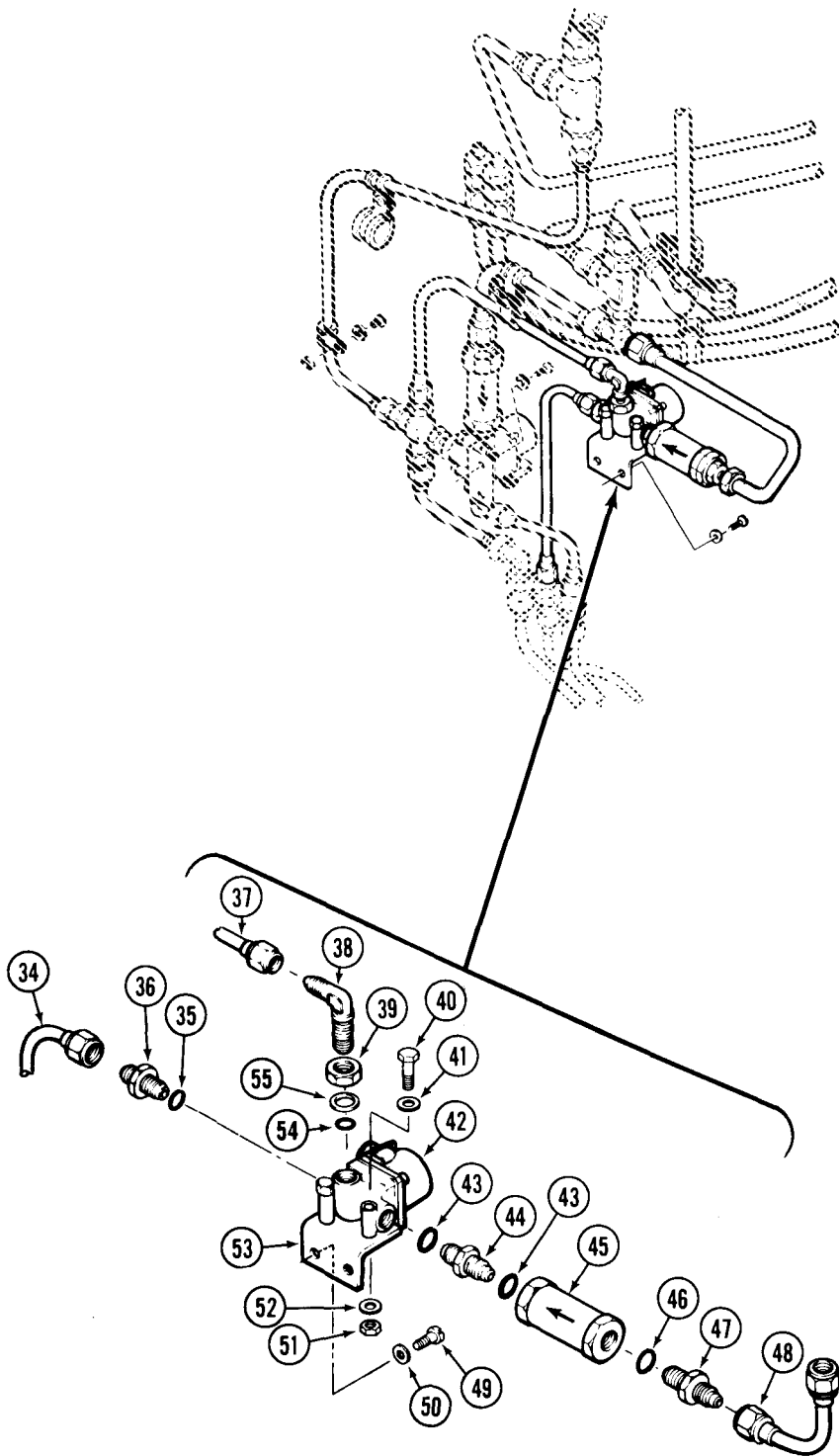

209076-54-2

Figure 7-28. Solenoid Valves (SCAS System) — Installation (Sheet 2 of 4)

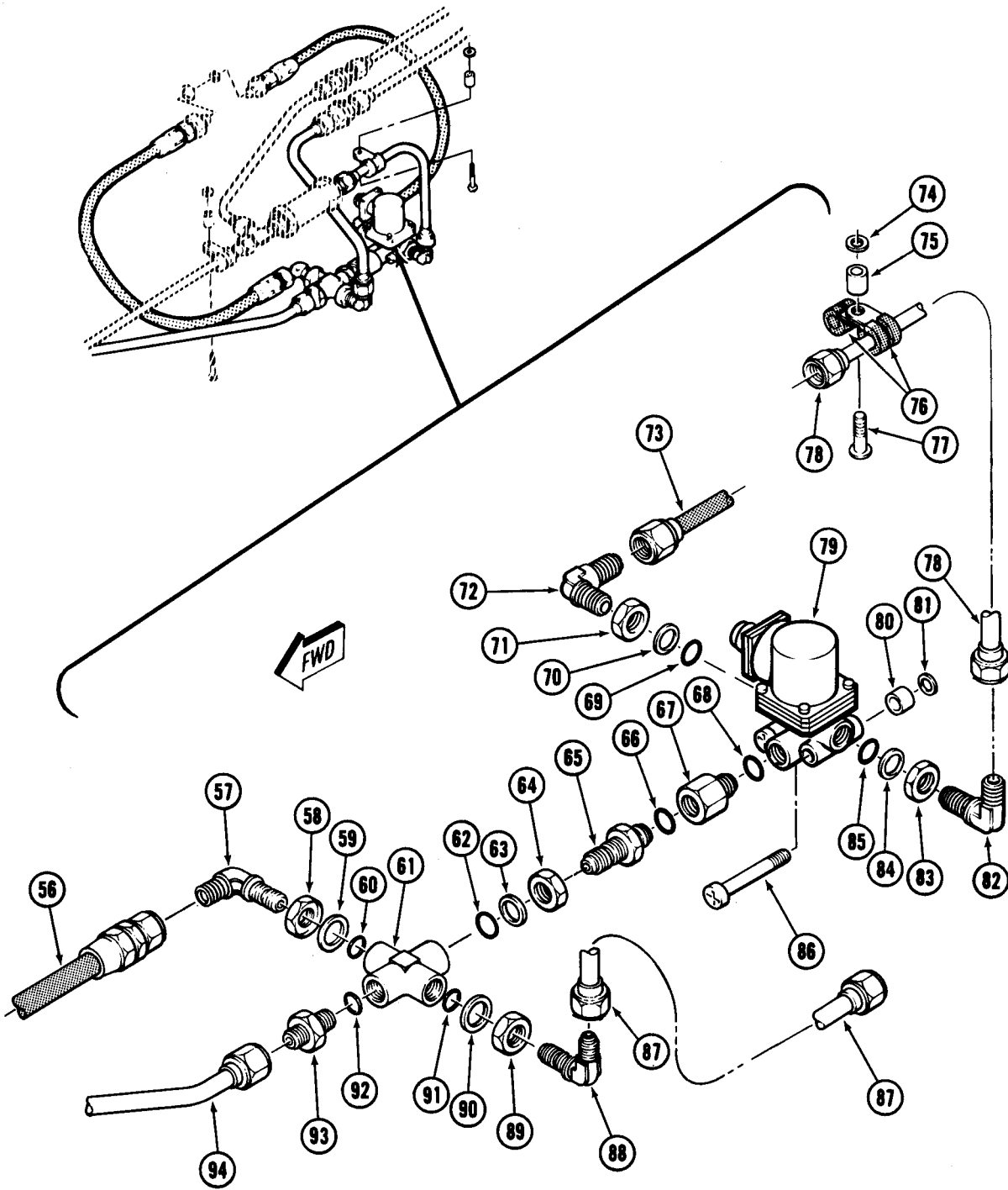

209076-54-3

Figure 7-28. Solenoid Valves (SCAS System) – Installation (Sheet 3 of 4)

- |  |  |
|--|--|
| 1. Tube assembly   | 48. Tube assembly  |
| 2. Tube assembly   | 49. Screw  |
| 3. Fitting   | 50. Washer   |
| 4. Packing   | 51. Nut  |
| 5. Tee   | 52. Washer   |
| 6. Bolt  | 53. Bracket  |
| 7. Washer  | 54. Packing  |
| 8. Tube assembly   | 55. Ring (backup)  |
| 9. Fitting   | 56. Hose assembly  |
| 10. Packing  | 57. Elbow  |
| 11. Filter   | 58. Nut  |
| 12. Packing  | 59. Ring (backup)  |
| 13. Fitting  | 60. Packing  |
| 14. Washer   | 61. Tee  |
| 15. Nut  | 62. Packing  |
| 16. Valve P/N 209-076-023-1<br>FSCM 16780 P/N 15353          | 63. Ring (backup)  |
| 17. Screw  | 64. Nut  |
| 18. Washer   | 65. Fitting  |
| 19. Tube assembly  | 66. Packing  |
| 20. Elbow  | 67. Bushing  |
| 21. Nut  | 68. Packing  |
| 22. Ring (backup)  | 69. Packing  |
| 23. Packing  | 70. Ring (backup)  |
| 24. Bracket  | 71. Nut  |
| 25. Packing  | 72. Elbow  |
| 26. Ring (backup)  | 73. Hose assembly  |
| 27. Nut  | 74. Washer   |
| 28. Fitting  | 75. Spacer   |
| 29. Packing  | 76. Clamps   |
| 30. Tube assembly  | 77. Screw  |
| 31. Fitting  | 78. Tube assembly  |
| 32. Packing  | 79. Solenoid valve P/N 209-076-023-1<br>FSCM 16780 P/N 15353 |
| 33. Fitting  | 80. Spacer   |
| 34. Tube assembly  | 81. Washer   |
| 35. Packing  | 82. Elbow  |
| 36. Fitting  | 83. Nut  |
| 37. Tube assembly  | 84. Ring (backup)  |
| 38. Elbow  | 85. Packing  |
| 39. Nut  | 86. Screw  |
| 40. Bolt   | 87. Tube assembly  |
| 41. Washer   | 88. Elbow  |
| 42. Solenoid valve P/N 209-076-023-2<br>FSCM 16780 P/N 15353 | 89. Nut  |
| 43. Packing  | 90. Ring (backup)  |
| 44. Fitting  | 91. Packing  |
| 45. Filter   | 92. Packing  |
| 46. Packing  | 93. Fitting  |
| 47. Fitting  | 94. Tube assembly  |

209076-54-4A

Figure 7-28. Solenoid Valves (SCAS System) — Installation (Sheet 4 of 4)

(b) Loosen nut (39) and remove elbow (38) from solenoid valve (42). Remove packing (54), (backup) ring (55) and nut (39) from elbow (38) and discard packing (54) and (backup) ring (55).

(c) Remove fitting (44), with filter (45), from solenoid valve (42). Remove fittings (44 and 47) from filter (45) and discard two packings (43) and packing (46).

(d) If filter (45) is not immediately being installed, install protective dust covers in open ports.

c. Remove solenoid valve (79, figure 7-28) for anti-torque (SCAS) system as follows.

(1) Remove access panel (38, figure 2-3).

(2) Disconnect electrical connector from solenoid valve (79, figure 7-28).

(3) Provide a suitable container for catching fluid seepage when disconnecting hose assemblies (56 and 73) and tube assemblies (78, 87, and 94) from solenoid valve (79).

(4) Remove hose assembly (56) from elbow (57) and install protective dust cover to hose connector.

(5) Remove hose assembly (73) from elbow (72) and install protective dust cover to hose connector.

(6) Remove screw (77), spacer (75), washer (74) and clamp (76).

(7) Remove tube assembly (78) from elbow (82) and install protective dust covers to connectors of tube assembly.

(8) Disconnect tube assembly (87) from elbow (88).

(9) Disconnect tube assembly (94) from fitting (93).

(10) Remove two screws (86), two spacers (80), two washers (81) and remove solenoid valve (79).

(11) Install protective dust covers to connectors of tube assemblies (87 and 94).

(12) Remove components from solenoid valve (79) as follows:

(a) Loosen nut (71) and remove elbow (72) from solenoid valve (79). Remove packing (69), (backup) ring (70) and nut (71) from elbow (72). Discard packing (69) and (backup) ring (70).

(b) Loosen nut (83) and remove elbow (82) from solenoid valve (79). Remove preformed packing (85), (backup) ring (84) and nut (83) from elbow (82). Discard packing (85) and (backup) ring (84).

(c) Remove bushing (67), with tee (61) from solenoid valve (79).

(d) Remove bushing (67) from fitting (65) and discard packings (66 and 68).

(e) Remove fitting (93) from tee (61) and discard packing (92).

(f) Loosen nut (64) and remove fitting (65) from tee (61). Remove packing (62), (backup) ring (63) and nut (64) from fitting (65). Discard packing (62) and (backup) ring (63).

(g) Loosen nut (89) and remove elbow (88) from tee (61). Remove packing (91), (backup) ring (90) and nut (89) from elbow (88). Discard packing (91) and (backup) ring (90).

(h) Loosen nut (58) and remove elbow (57) from tee (61). Remove packing (60), (backup) ring (59) and nut (58) from elbow (57). Discard packing (60) and (backup) ring (59).

7-111. **P** CLEANING CLEANING – ASSEMBLED SOLENOID VALVES P/N 209-076-023-1 FSCM 16780 P/N 15353 (7, 9, and 19, figure 7-1).

**WARNING**

Cleaning solvent is flammable and toxic. Provide adequate ventilation. Avoid prolonged breathing of solvent vapors and contact with skin or eyes. Eye protection is required when using compressed air.

**CAUTION**

To prevent damaging internal components, do not submerge solenoid valve in solvent. Cap open ports prior to cleaning.

a. Clean assembled solenoid valves (7, 9 and 19) with clean cloths dampened with solvent (C112), use a soft bristle brush and a piece of soft copper wire may be required to remove stubborn deposits of dirt/oil from external surfaces.

b. Allow to air dry or blow dry using cleaned filtered compressed air.

**7-112. P INSPECTION — SOLENOID VALVES P/N 209-076-023-1 FSCM 16780 P/N 15353 (7, 9, and 19 figure 7-1).**

a. Inspect electrical connector for bent or broken pins and damaged threads.

b. Inspect ports for damaged threads.

c. Inspect external surfaces for nicks, dents and cracks. No cracked parts are acceptable.

**7-113. P REPAIR OR REPLACEMENT – SOLENOID VALVES P/N 209-076-023-1 FSCM 16780 P/N 15353 (AVIM) (7, 9, and 19, figure 7-1).**

a. Replace solenoid valves (7, 9 and 19) that fail to meet inspection requirements of paragraph 7-112.

b. Refer to paragraphs 7-110 and 7-114 for removal and installation instructions.

**7-114. P INSTALLATION – SOLENOID VALVES P/N 209-076-023-1 FSCM 16780 P/N 15353 (7, 9 and 19, figure 7-1).**

a. Install solenoid valve (16, figure 7-28) for fore and aft (SCAS) system as follows:

(1) Remove protective dust covers from solenoid valve (16) and drain preservative hydraulic fluid from solenoid valve, flush solenoid valve with clean hydraulic fluid (C61 or C62).

(2) Apply a light film of hydraulic fluid (C61 or C62) to all packings, threads, and tube connectors prior to assembly of parts with the exception of bolts (17).

(3) Install two packings (12) on fitting (13) and install fitting into PRESS port of solenoid valve (16).

(4) Position filter (11), with directional flow arrow pointing toward PRESS port, and install filter to fitting (13).

(5) Install packing (10) on fitting (9) and install fitting to filter (11).

(6) Install nut (21), backup ring (22), and packing (23) on elbow (20). Position and install elbow into CYL port of solenoid valve (16).

(7) Install packing (29), nut (27), backup ring (26) and packing (25) on fitting (28). Install fitting to tee (5).

(8) Install packing (29) on fitting (33) and install fitting to tee (5).

(9) Install packing (32) to fitting (31) and install fitting to tee (5).

(10) Thread fitting into RET port of solenoid valve (16), position tee (5) as shown and tighten nut (27).

(11) Remove protective dust covers from tube assemblies (1, 8, 19 and 30).

(12) Buff mounting pads of solenoid valve to ensure good electrical bond. Position solenoid valve (16) on bracket (24) and install two bolts (6), two washers (7), two washers (14), and two nuts (15).

(13) Install tube assemblies (1, 8, 19, and 30) on solenoid valve (16), and torque tube connectors in accordance with torque requirements outlined in table 7-4.

(14) Connect electrical connector to solenoid valve (16).

(15) Fill reservoirs to proper level with clean hydraulic fluid (C61 or C62) (paragraph 7-6).

(16) Perform operational check of fore and aft cyclic (SCAS) actuator and bleed hydraulic system (paragraph 7-3). Refill reservoirs.

b. Install solenoid valve (42, figure 7-28) for lateral (SCAS) system.

(1) Remove protective dust covers from solenoid valve (42) and drain preservative hydraulic fluid from bypass solenoid valve. Flush solenoid valve with clean hydraulic fluid (C61 or C62).

(2) Apply a light film of hydraulic fluid (C61 or C62) to all packings, threads and tube connectors

prior to assembly of parts with the exception of bolts (49).

**(3)** Install two packings (43) on fitting (44) and install fitting into PRESS Port of solenoid valve (42).

**(4)** Position filter (45), with directional flow arrow pointing toward PRESS port and install filter to fitting (44).

**(5)** Install packing (46) to fitting (47) and install fitting to filter (45).

**(6)** Install packing (35) on fitting (36) and install fitting to CYL port of solenoid valve (42).

**(7)** Install nut (39), backup ring (55) and packing (54) on elbow (38). Thread elbow into RETURN port of solenoid, position elbow as shown and tighten nut (39).

**(8)** Remove protective dust covers from tube assemblies (34, 37, and 48).

**(9)** Buff mounting pads of solenoid valve to ensure good electrical bond. Position solenoid valve (42) on bracket (53) and install two bolts (40), two washers (41), two washers (52) and two nuts (51).

**(10)** Install tube assemblies (34, 37, and 48) on solenoid valve (42) and torque tube connectors in accordance with torque requirements outlined in table 7-4.

**(11)** Connect electrical connector to solenoid valve (16).

**(12)** Fill reservoirs to proper level with clean hydraulic fluid (C61 or C62) (paragraph 7-6).

**(13)** Perform operational check of lateral cyclic (SCAS) actuator and bleed hydraulic system (paragraph 7-3). Refill reservoirs.

**c.** Install solenoid valve (79, figure 7-28) for anti-torque (SCAS) system.

**(1)** Remove protective dust covers from solenoid valve (79) and drain preservative hydraulic fluid from solenoid valve. Flush solenoid valve with clean hydraulic fluid (C61 or C62).

**(2)** Apply a light film of hydraulic fluid (C61 or C62) to all packings, threads and tube connectors

prior to assembly of parts with the exception of screws (86).

**(3)** Install nut (64), backup ring (63) and two packings (62 and 66) on fitting (65) and install fitting on bushing (67).

**(4)** Install packing (68) on bushing (67) and install bushing into RET port of solenoid valve (79).

**(5)** Install packing (92) on fitting (93) and install fitting on tee (61).

**(6)** Install nut (58), backup ring (59) and packing (60) on elbow (57). Thread elbow into tee (61), position elbow as shown, and tighten nut (58).

**(7)** Install nut (89) backup ring (90), and packing (91) on elbow (88). Thread elbow into tee (61), position elbow as shown, and tighten nut (89).

**(8)** Thread fitting (65) into tee (61), position tee as shown and tighten nut (64).

**(9)** Install nut (71), backup ring (70), and packing (69) on elbow (72). Thread elbow into CYL port of solenoid valve (79), position elbow as shown, and tighten nut (71).

**(10)** Install nut (83) backup ring (84), and packing (85) on elbow (82). Thread elbow into PRESS port of solenoid valve (79), position elbow as shown, and tighten nut (83).

**(11)** Remove protective dust covers from tube assemblies (78, 87, and 94).

**(12)** Buff mounting pads to solenoid valve to ensure good electrical bond. Position solenoid valve (79) to bracket and install two screws (86), two spacers (80) and two washers (81), as shown.

**(13)** Install tube assemblies (78, 87, and 94) to solenoid valve (79). Refer to table 7-4 for torque requirements of tube connectors.

**(14)** Remove protective dust covers from hose assemblies (56 and 73) and install hose assemblies to elbows (57 and 72). Torque hose connectors in accordance with torque requirements outlined in table 7-4.

**(15)** Install clamp (76), screw (77), spacer (75), and washer (74) as shown.



(16) Connect electrical connector to solenoid valve (79).

(17) Using hydraulic fluid dispenser (S1), fill reservoirs to proper level with clean hydraulic fluid (C61 or C62) (paragraph 7-6).

(18) Perform operational check of directional (SCAS) actuator and bleed hydraulic system (paragraph 7-3). Refill reservoirs.

**7-115. P SOLENOID VALVE P/N 7U7464 (23 and 24, figure 7-1).**

**7-116. P DESCRIPTION – SOLENOID VALVE P/N 7U7464 (23 and 24, figure 7-1).**

Two, two-position solenoid valves (23 and 24) are included in the hydraulic system to permit shutting off fluid circulation to the turret and the wing pylon actuators. The solenoid valves are controlled by the pilot MASTER ARM Switch. See FO-1 (foldout 1) for view of hydraulic system schematic.

**Premaintenance Requirements For Hydraulic Solenoid Valves**

Conditions	Requirements
Model	AH-1S
Part No. or Serial No.	7U7464
Special Tools	None
Test Equipment	Hydraulic test stand (S2) Functional Test Setup (figure 7-31) Pressure Drop Test Setup (figure 7-33) 30 Vdc Power Supply
Support Equipment	None
Minimum Personnel Required	Two
Consumable Materials	(C22) (C30) (C31) (C36) (C37) (C61) (C62) (C63) (C88) (C91) (C112) (C137) (C138)
Special Environmental Conditions	None

**7-117. P REMOVAL — SOLENOID VALVES P/N 7U7464 (23 and 24, figure 7-1).**

a. Remove solenoid valve (4, figure 7-29) as follows:

(1) Remove left fuselage panel (17, figure 2-3).

(2) Disconnect electrical connector from solenoid valve, (4, figure 7-29).

(3) Provide a suitable container to catch fluid seepage when disconnecting tube assemblies (13 and 18).

(4) Disconnect tube assemblies (1, 13, and 18) from solenoid valve (4).

(5) Remove two bolts (12) and two washer (5) attaching solenoid valve (4) to bulkhead and remove solenoid valve.

(6) Drain fluid from solenoid valve (4) and remove union reducer (2). Remove preformed packing (3) from union reducer (2).

(7) Remove union (14) from tee (16) and, remove packing (15) from union.

(8) Remove union (17) from tee (16) and remove packing (11) from union.

(9) Loosen nut (8) and remove tee (16) with union reducer (9) from solenoid valve (4).

(10) Remove packing (6), (backup) ring (7) and nut (8) from union reducer (9).

(11) Remove union reducer (9) from tee (16) and remove packing (10) from union reducer.

(12) Install protective dust covers to open ports and electrical connector of solenoid valve (4) to prevent entry of foreign particles.

b. Remove solenoid valve (23, figure 7-29) as follows:

(1) Remove left fuselage (7, figure 2-3) panel.

(2) Disconnect electrical connector from solenoid (23, figure 7-29).

(3) Provide a suitable container to catch fluid seepage when disconnecting tube assembly (29).

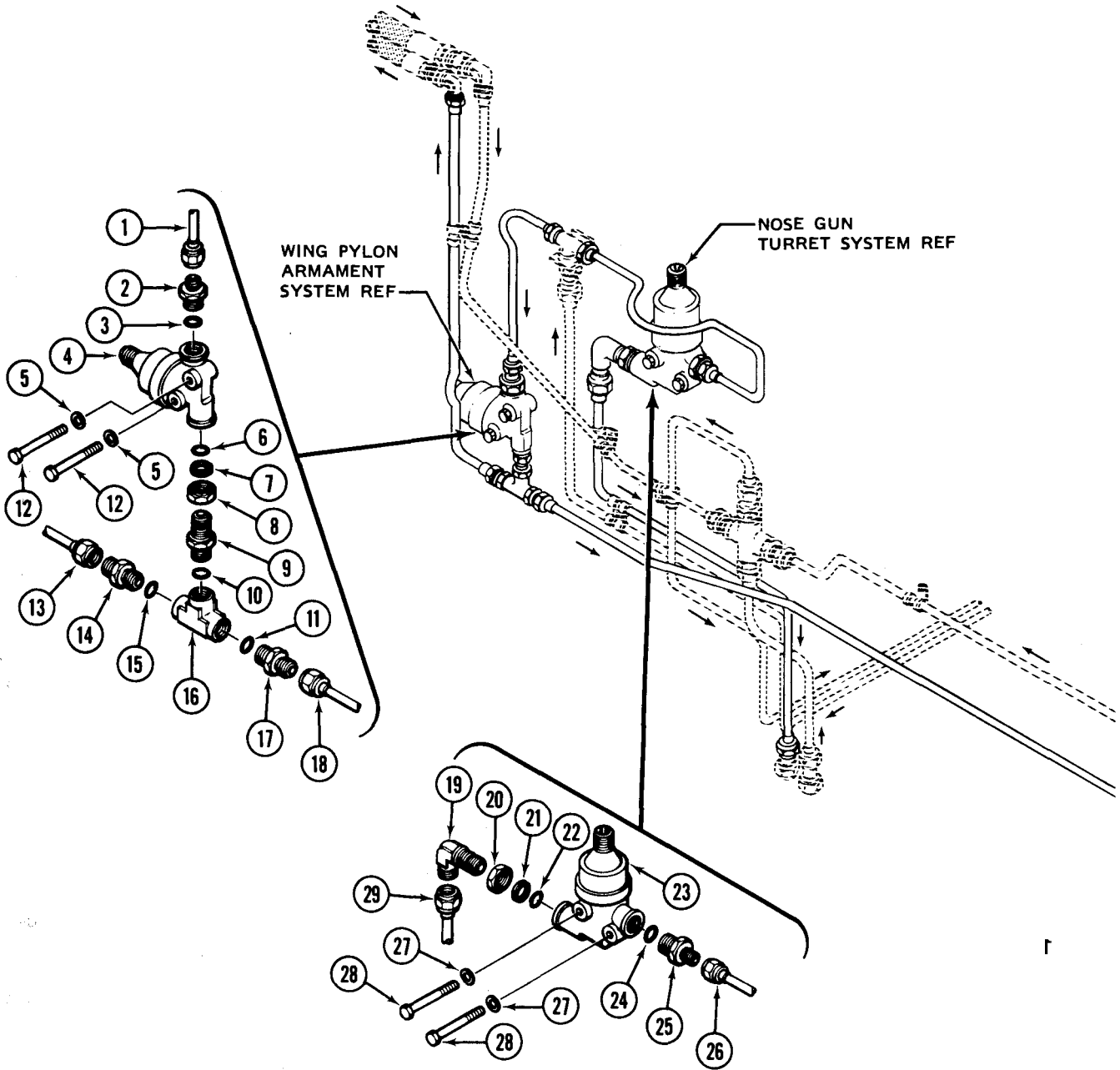

- 1. Tube assembly
- 2. Union reducer
- 3. Packing
- 4. Solenoid valve P/N 7U7464
- 5. Washers
- 6. Packing
- 7. Ring (backup)
- 8. Nut
- 9. Union reducer
- 10. Packing

- 11. Packing
- 12. Bolts
- 13. Tube assembly
- 14. Union
- 15. Packing
- 16. Tee
- 17. Union
- 18. Tube assembly
- 19. Elbow
- 20. Nut

- 21. Ring (backup)
- 22. Packing
- 23. Solenoid valve P/N 7U7464
- 24. Packing
- 25. Union
- 26. Tube assembly
- 27. Washers
- 28. Bolts
- 29. Tube assembly

214076-12A

Figure 7-29. P Solenoid Valve P/N 7U7464 Installation

(4) Disconnect tube assemblies (26 and 29) from solenoid valve (23).

(5) Remove two bolts (28) and two washers (27) from attaching solenoid valve (23) to bulkhead and remove solenoid valve.

(6) Drain hydraulic fluid from solenoid valve (23) and remove union (25). Remove packing (24) from union (25).

(7) Loosen nut (20) and remove elbow (19) from solenoid valve (23). Remove packing (22), (backup) ring (21) and nut (20) from elbow (19).

(8) Remove union (25).

(9) Install protective dust covers to open ports and electrical connector of solenoid valve (23) to prevent entry of foreign particles.

**7-118. P PROTECTIVE – SOLENOID VALVE P/N 7U7464 (23 and 24, figure 7-1).**

a. Clean assembled solenoid valves (23 and 24) in same manner outlined in paragraph 7-111.

b. Clean disassembled solenoid valves (23 and 24) as outlined in paragraph 7-102.

**7-119. P INSPECTION – SOLENOID VALVE P/N 7U7464 (23 and 24, figure 7-1).**

a. Inspect assembled solenoid valves (23 and 24) as follows:

(1) Inspect electrical connector for bent or broken pins and damaged threads.

(2) Inspect ports for damaged threads.

(3) Inspect external surfaces for nicks, dents, and cracks. No cracked parts are acceptable.

b. Inspect disassembled solenoid valves (23 and 24) as outlined in paragraph 7-12).

**7-120. P DISASSEMBLY – SOLENOID VALVE P/N 7U7464 (23 and 24, figure 7-1).**

a. Install solenoid valve (23 or 24) in a suitable smooth-jawed bench vise.

b. Remove lockwire from nut (13, figure 7-30).

c. Using a spanner wrench, remove nut (13) from solenoid valve.

d. Remove coil assembly (11) from body (1).

e. Remove lap assembly (5) and spring (4) from body (1).

f. Remove two backup rings (2) and two packings (3) from lap assembly (5).

g. Remove backup ring (6), packing (7), pole (8), and plunger assembly (10) from coil assembly (11).

**7-121. P INSPECTION – SOLENOID VALVE P/N 7U7464 (AVIM) (23 and 24, figure 7-1).**

a. Inspect all parts for nicks, scratches, cracks and corrosion. Use a strong light and magnifying glass. No cracked parts are acceptable.

(1) Inspect body (1, figure 7-30) and nut (13) for damaged threads.

(2) Inspect all packing grooves for surface defects that might cut packings during installation or cause sealing failure during operation.

(3) Inspect plunger assembly (10) for evidence of galling or scoring.

(4) Inspect electrical receptacle of coil assembly (11) for broken or bent pins.

(5) Inspect sleeve (5) and piston (14) for nicks, scratches, or other visible damage to lapped surfaces.

(6) Inspect spring (4) for deformation. Deformed springs are not acceptable.

(7) Inspect nameplate on body (1) for legibility and security of attachment. Damaged, loosely attached, or missing nameplates are not acceptable.

(8) Inspect parts listed in table 7-9, 1 for conformance to non-destructive test data specified in TM 43-0103.

(9) Inspect parts listed in table 7-10 for conformance to dimensions specified.

(10) Inspect parts listed in Table 7-10 for conformance to dimensions specified.

Table 7-9. **P** Non-Destructive Test Requirements For Solenoid Valve  
P/N 7U7464 (AVIM)

NOMENCLATURE	FIGURE 7-30 INDEX NO. 23	TYPE OF TEST	PROCEDURE	REMARKS
Nut	13	Magnetic Particle Inspect	Inspect for cracks and strains per MIL-I-6868 and TM 43-0103	If defective, replace with new part.
Piston	14	Magnetic Particle Inspect	Inspect for cracks and strains per MIL-I-6868 and TM 43-0103	If defective, replace with new part.
Sleeve	5	Magnetic Particle Inspect	Inspect for cracks and strains per MIL-I-6868 and TM 43-0103	If defective, replace with new part.
Body	1	Fluorescent Penetrant Inspect	Inspect for cracks per MIL-I-6868 and TM 43-0103	If defective, replace valve.
Spring	4	Dimension and Load	Test Load: <b>15 ± 0.5</b> pounds at <b>0.550</b> inch	Permanent set shall not result from test load. Spring shall not wobble when rolled across a flat surface.
Coil Assembly	11	Dielectric and Insulation-Resistance	Apply <b>1000</b> volts ac rms between both receptacle pins and coil assembly case for <b>10</b> seconds	Replace coil assembly if any evidence of dielectric breakdown or leakage. Resistance shall be at least <b>5</b> megohms. Apply <b>500</b> Volts DC between both receptacle pins and ease coil assembly

**Table 7-10. P** Diametrical Clearance Requirements for Solenoid Valve  
P/N 7U7464 (AVIM)

NOMENCLATURE	FIGURE 7-26 INDEX NO.	DIAMETRICAL MAX.	CLEARANCE (IN) MIN.	REMARKS
Pin	9	0.0100	0.0030	Pin (9) to fit pole (8) center I.D.

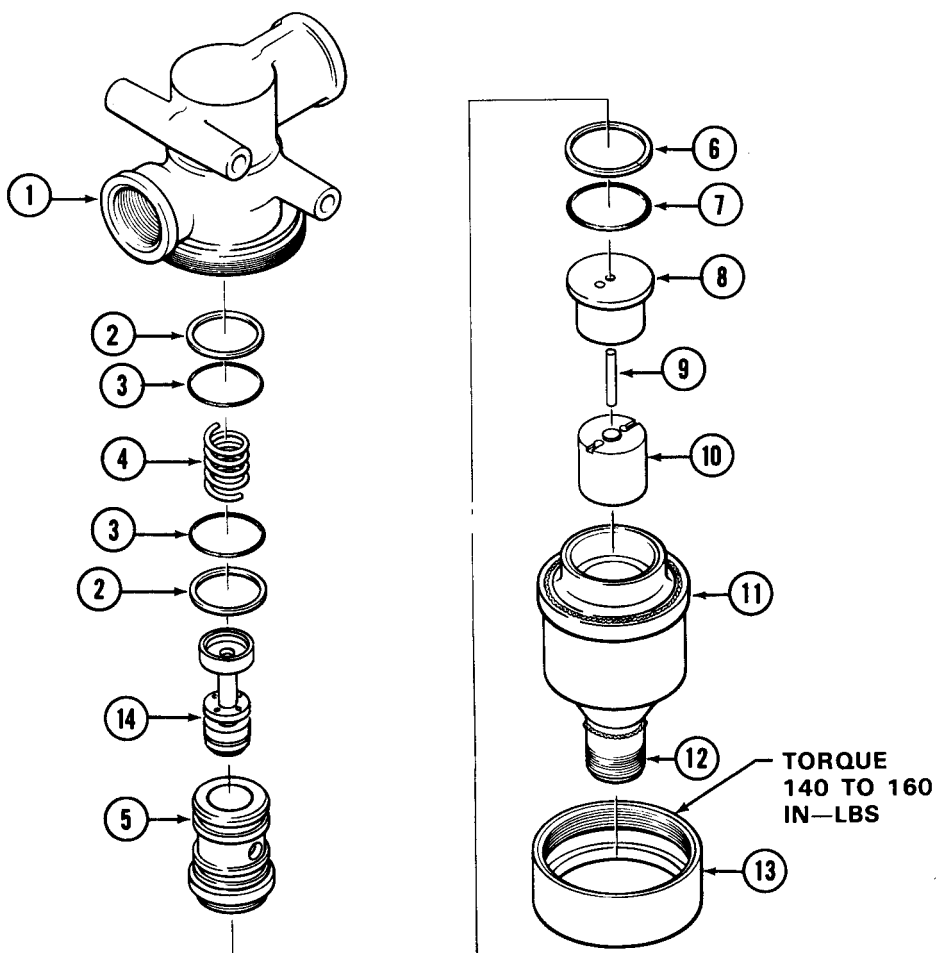

- |                          |                            |
|--------------------------|----------------------------|
| 1. Body                  | 8. Pole                    |
| 2. Ring (backup)         | 9. Pin                     |
| 3. Packing               | 10. Plunger assembly       |
| 4. Spring                | 11. Coil assembly          |
| 5. Lap assembly (sleeve) | 12. Connector (electrical) |
| 6. Ring (backup)         | 13. Nut                    |
| 7. Packing               | 14. Lap assembly (piston)  |

204076-1011A

**Figure 7-30. P** Solenoid Valve P/N 7U7464 Assembly

**7-122. P REPAIR – DISASSEMBLED SOLENOID VALVE P/N 7U7464 (AVIM) (23 and 24, figure 7-1).**

a. Polish out minor nicks and scratches on metal parts with crocus cloth (C37) (for steel parts) and abrasive cloth (C36) (for aluminum parts), provided that dimensions specified in table 7-9 are maintained, and seating and sealing surfaces are not damaged.



**Chemical film material is extremely dangerous. Contact with combustible materials will cause explosion or fire. Avoid contact with skin or eyes.**

b. Treat repaired area of anodized finish, after polishing, with chemical film material (C31).

c. If pin (9, figure 7-30) requires replacement, trim end of new pin to provide a stroke of **0.025 TO 0.027** inch when pin is installed in pole (5).

d. Replace plunger assembly (10) if pin (9) is damaged, or loose, or if plunger assembly shows other visible evidence of damage.

e. Straighten bent pins of electrical receptacle (12) of coil assembly (11). If pins are broken, or if coil assembly is defective, replace coil assembly.

f. Replace packing (3 and 7) and rings (backup) (2 and 6) each time valve is disassembled.

g. If sleeve (5) or piston (14) is defective, replace both parts as an assembly.

h. Replace all worn or damaged parts which cannot be reworked to meet inspection requirements.

i. Replace nameplate on body (1) when damaged, loosely attached, or missing.

**7-123. P ASSEMBLY – SOLENOID VALVES P/N 7U7464 (23 and 24, figure 7-1),**

a. Apply a light coat of hydraulic fluid (C61 or C62) to all internal parts prior to assembly.

b. Place body (1, figure 7-30) in a smooth-jawed bench vise.

c. Install two packings (3) and two (backup) rings (2) on lap assembly (5).

d. Install spring (4) and lap assembly (5) into body (1).

e. Install plunger assembly (10), pin (9), pole (8), and packing (7) into coil assembly (11). Secure pole (8) with backup ring (6).

f. Install coil assembly (11) and nut (13) to body (1). Torque nut (13) **140 TO 160** inch-pounds and secure with lockwire (C138).

g. Ensure that all open ports and electrical connector are either plugged or capped.

h. If solenoid valve is not immediately being installed in helicopter and will require storage, fill solenoid valve with preservative hydraulic fluid (C63).

**7-124. P TESTING – SOLENOID VALVE P/N 7U7464 (23 and 24, figure 7-1),**

a. Inspect hydraulic test stand (S2) to ensure that it meets the following requirements:

(1) Capable of providing pressures to **2300** psig at flow rate of 3 gpm.

(2) Equipped for filtration of particles to **10** microns in size.

(3) Services with clean hydraulic fluid (C61 or C62).

(4) Capable of maintaining hydraulic fluid within a temperature range of **+21** degrees C (**+70** degrees F) to **+43** degrees C (**+110** degrees).

b. Refer to table 7-11 if trouble is encountered during procedures in steps c through g.

c. **Break-in Run Test.** Install solenoid valve in a test setup similar to that shown in figure 7-31 and perform the following tests:

(1) Check solenoid valve to ensure flow is as shown on figure 7-32 with the solenoid valve energized and de-energized.

(2) Energize solenoid valve with **18** volts dc.

(3) Adjust regulator valve until a fluid pressure of 1500 psig is indicated on gage A.

Table 7-11. Troubleshooting During Test of Solenoid Valve P/N 7U7464 (AVIM)

---

 CONDITION

## TEST OR INSPECTION

**CORRECTIVE ACTION**

1. Solenoid valve inoperative or does not operate smoothly.

STEP 1. Defective coil assembly (11, figure 7-30).

**Replace coil assembly (11). Refer to paragraph 7-117.**

STEP 2. Defective plunger assembly (10).

**Replace plunger (10). Refer to paragraph 7-117.**

STEP 3. Pin (9) worn.

**Replace pin (9). Refer to paragraph 7-117.**

STEP 4. Defective pole (8).

**Replace pole (8). Refer to paragraph 7-117.**

STEP 5. Defective lap assembly (5).

**Replace lap assembly (5). Refer to paragraph 7-117.**

STEP 6. Defective spring (4).

**Replace spring (4). Refer to paragraph 7-117.**

2. External leakage.

STEP 1. Packing (7) damaged or incorrectly installed.

**Replace or reinstall packing (7), Refer to paragraph 7-117.**

3. Internal leakage not within limits specified.

STEP 1. Packing(s) (3) damaged or incorrectly installed.

**Replace or reinstall packing(s) (3). Refer to paragraph 7-117.**

STEP 2. Defective spring (4).

**Replace spring (4). Refer to paragraph 7-117.**

STEP 3. Defective lap assembly (5).

**Replace lap assembly (5). Damage to either sleeve (5) or piston (14) of lap assembly (5) required that both parts be replaced as an assembly. Refer to paragraph 7-117.**

---

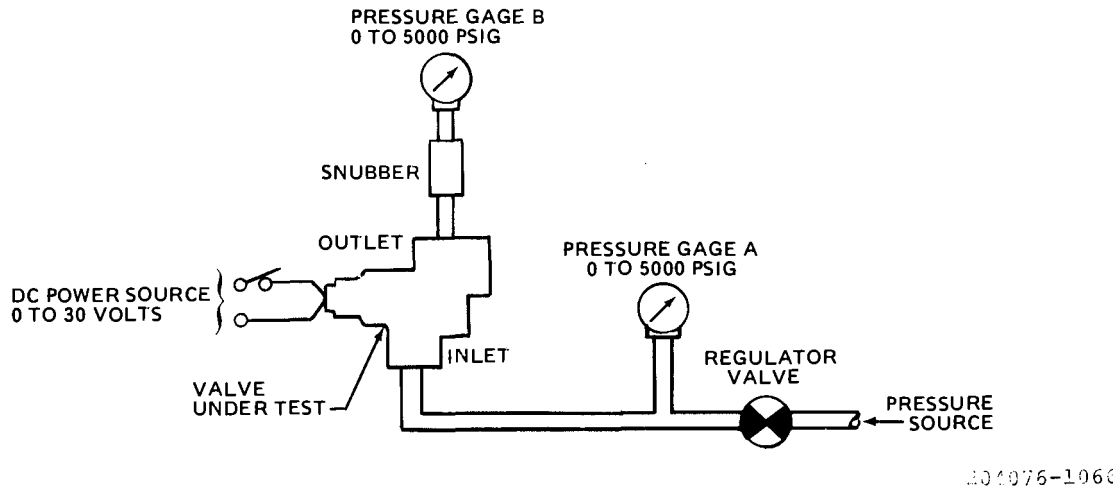

Figure 7-31. **P** Functional Test Setup For Solenoid Valve P/N 7U7464

(4) Cycle solenoid valve under test 25 times by alternately energizing or de-energizing solenoid. Valve shall operate smoothly and without hesitation at a flow rate of 6 gpm.

(5) Remove pressure and disconnect flowmeter.

**d. Proof pressure test.** Install solenoid valve in a test setup similar to that shown in figure 7-31 and perform the following:

(1) Adjust regulator valve to apply 2250 psig. Energize and de-energize solenoid to equalize pressure. Maintain pressure for 2 minutes; there must be no evidence of external leakage or visible distortion of valve.

(2) Reduce pressure to 25 psig. Energize and de-energize solenoid to equalize pressure. Maintain

pressure for 2 minutes; there must be no evidence of external leakage or visible distortion of valve.

(3) Increase pressure to 2250 psig. Energize and de-energize to equalize pressure. Maintain pressure for 2 minutes; there must be no evidence of external leakage or visible distortion.

(4) Decrease pressure to zero.

**e. Operating Voltage Test.** With solenoid valve installed in a test setup similar to that shown in figure 7-31, perform the following tests:

(1) Ensure that coil temperature is between +21 degrees C (+70 degrees F) and +43 degrees C (+110 degrees F).

(2) Adjust pressure regulator to supply 1500 psig.

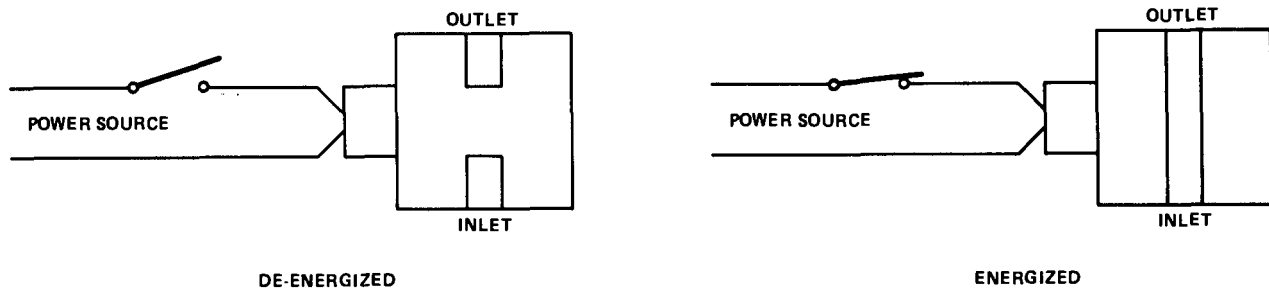

Figure 7-32. **P** Flow Diagram For Solenoid Valve P/N 7U7464



(3) Energize solenoid valve with a maximum of **15.3** volts dc; then de-energize solenoid valve. Valve operation, as indicated by gage B, must be instantaneous with no evidence of sluggishness.

(4) Increase applied pressure to **2250** psig. Repeat procedure described in step (c), except energize solenoid valve to **28** volts dc.

**f. Internal Leakage Test.** With solenoid valve still installed in a test setup similar to that shown in figure 7-31, perform the following tests:

(1). De-energize solenoid and remove connections from outlet port.

(2) Adjust pressure regulator to apply **1500** psig. Maintain pressure for at least **2** minutes. Maximum acceptable internal leakage from the outlet port is **10** cubic centimeters per minute.

**g. Pressure Drop Test.** Install solenoid valve in a test setup similar to that shown in figure 7-33 and perform the following tests:

(1) Adjust pressure regulator to gradually apply pressure to obtain a flow rate of **6** gpm. Maximum acceptable pressure required is **50** psig plus "tare". Record pressure required to obtain **6** gpm flow.

(2) Remove solenoid valve and install a piece of **4.0** inch long tubing with **0.375** inch outside diameter and **0.041** inch maximum wall thickness. Use identical fittings to these used in step (1). Adjust

pressure regulator gradually to apply pressure until a flow rate of **6** gpm is obtained. Pressure required to obtain **6** gpm is "tare". Record this "tare" figure.

(3) Subtract "tare" figure recorded in step (2) from pressure recorded in step (1). If result is in excess of **50** psig, the solenoid valve is unsatisfactory.

**h. Dielectric Strength Test.**

(1) Apply **1000** volts ac between one pin of the valve receptacle and the solenoid case for **10** seconds. No breakdown or flashover is acceptable.

(2) Repeat step (a) with the other pin in the valve receptacle.

**i. Insulation Resistance Test.**

(1) Apply **500** volts dc between one pin of the valve receptacle and the solenoid case. Minimum acceptable resistance is **5** megohms.

(2) Repeat step (1) with the other pin in the valve receptacle.

**j. Preservation.** After completion of testing, torque nut (figure 7-30) **140 TO 160** inch-pounds and secure with lockwire (C138). Flush solenoid valve with hydraulic fluid (C63); drain fluid after flushing. Mark rubber parts cure date on identification tag. Plug or cap all ports with dust protective covers. Wrap solenoid valve in barrier material (C22) or equivalent.

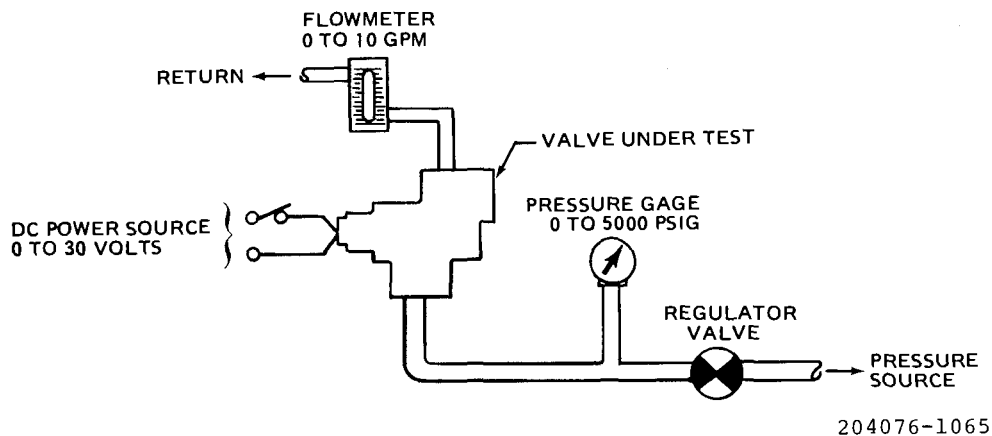

Figure 7-33. **P** Pressure Pressure Drop Test Setup For Solenoid Valve P/N 7U7464

**7-125. P INSTALLATION INSTALLATION – SOLENOID VALVE P/N 7U7464 (23 and 24, figure 7-1).**

a. install solenoid valve (4, figure 7-29) as follows:

(1) Remove protective dust covers from solenoid valve and drain preservative hydraulic fluid from solenoid valve. Flush solenoid valve with clean hydraulic fluid (C61 or C62).

(2) Apply a light film of hydraulic fluid (C61 or C62) to all packings, threads and tube connectors prior to assembly or part, with the exception of bolts (28).

(3) Install nut (8), (backup) ring (7) and packing (6) on union reducer (9). Thread union reduce into OUTLET port of solenoid valve (4), position tee (16) as shown and tighten nut (8).

(4) Install packing (11) on union (17) and install union into tee (16).

(5) Install packing (15) on union (14) and install union into tee (16).

(6) Install packing (3) on union reducer (2) and install reducer into INLET port of solenoid valve (4).

(7) Remove protective dust covers from tube assemblies (1, 13, and 18).

(8) Buff mounting pads of solenoid valve (4) to ensure good electrical bond. Position solenoid cables valve to bulkhead as shown and install two bolts (21) and two washers (5).

(9) Connect and torque tube assemblies (1, 13, and 18) in accordance with table 7-4.

(10) Install electrical connector to solenoid valve (4) and secure with lockwire (C137).

(11) Install left access panel to fuselage, below wing.

(12) Fill reservoir to proper level with clean hydraulic fluid (C61 or C62). Refer to paragraph 7-67 for servicing of reservoir.

(13) Perform operational check of hydraulic system. Refer to paragraph 7-3. Refill reservoir.

(14) Ensure that all air has been bled from system prior to next flight by cycling cyclic stick a minimum of 10 full cycles.

b. Install solenoid valve (23, figure 7-29) as follows:

(1) Remove protective dust covers from solenoid valve and drain preservative hydraulic fluid from solenoid valve. Flush solenoid valve with clean hydraulic fluid (C61 or C62).

(2) Apply a light film of hydraulic fluid (C61 or C62) to all preformed packings, threads and tube connectors prior to assembly of part, with the exception of bolts (28).

(3) Install nut (20), backup ring (21) and preformed packing (22) on elbow (19). Thread elbow into OUTLET port of solenoid valve (23), position elbow as shown and tighten nut (20).

(4) Install preformed packing (24) on union (25) and install union into INLET port of solenoid valve.

(5) Buff mounting pads of solenoid valve (23) to ensure good electrical bond. Position solenoid valve on bulkhead as shown and install two bolts (28) and two washers (27).

(6) Connect and torque tube assemblies (26 and 29) in accordance with table 7-4.

(7) Install electrical connector on solenoid valve (23) and secure with lockwire (C137).

(8) Install left access panel to fuselage, below wing.

(9) Using hydraulic fluid dispenser (S1), fill reservoirs to proper level with clean hydraulic fluid (C61 or C62) (paragraph 7-6).

(10) Perform operational check of hydraulic system (paragraph 7-3). Refill reservoirs.

(11) Ensure that all air has been bled from system prior to next flight (paragraph 7-3).

**7-126. P SERVO SERVO ACTUATOR (ELECTROHYDRAULIC) – ARMAMENT WING PYLON.**

**7-127. P DESCRIPTION – SERVO ACTUATOR (ELECTROHYDRAULIC) – ARMAMENT WING PYLON.**

Hydraulic provisions for the articulated wing pylon consists of a solenoid operated shutoff valve, closed when de-energized and open when energized, which is located in hydraulic System No. 2 press line, to direct flow to the electrohydraulic servo actuators located on outboard end of each wing pylon. The return flow from these servo actuators is directed through wing pylons paralleling the pressure line and terminating in the existing return line.

The electrohydraulic servo actuators used to power the articulated wing pylons are designed to operate as one position locked members until solenoid valve is opened to System No. 2 pressure; at this time the locking mechanism will disengage at 50 psig increasing pressure, the servo actuator will then function as a load moving cylinder. To return to the locked mode, the electrical circuit will be placed in stow position, the servo actuator will return to a predetermined position, and will automatically lock at 100 psig decreasing pressure.

**Premaintenance Requirements for Armament Wing Pylon Servo Actuator (Electrohydraulic) (AVIM)**

Condition	Requirements
Model	AH-1S
Part No, or Serial No.	209-076-035-1 and -2 (2-7323-1 and -2)
Special Tools	(T5) (T6)
Test Equipment	None
Support Equipment	(S2) (S13)
Minimum Personnel Required	Two
Consumable Materials	(C61) (C62) (C112) (C137) (C88) (C91) (C31) (C63) (C102) (C37) (C116)

Conditions	Requirements
Special Environmental Conditions	Test bench must maintain the fluid temperature at 90 degrees F ±20 degrees F (32 ± 12 degrees C) and be located in an area where the temperature can be maintained at 80 degrees F ± 10 degrees F (27 ± 6 degrees C)

**7-128. P REMOVALREMOVAL – SERVO ACTUATOR (ELECTROHYDRAULIC) – ARMAMENT WING PYLON.**

- a. Remove cowling from rack assembly.
- b. Provide a suitable container to catch spilled hydraulic fluid.
- c. Disconnect electrical connector from servo actuator.
- d. Disconnect hose from fittings at pressure and return port on servo actuator. Cover openings.
- e. Disconnect servo actuator from fittings by removing bolts, nuts and washers.

**7-129. P DISASSEMBLY – SERVO ACTUATOR (ELECTROHYDRAULIC) – ARMAMENT WING PYLON. (AVIM)**

- a. Remove lockwire (4, figure 7-34) cap screws (2) and servo valve (5) from body assembly (14 or 15). Install protective cover on servo valve (5).
- b. Remove lockwire (4) from cap screws (7).
- c. Remove cap screws (7).
- d. Remove locking key (30), jamnut (29), and spring seat (28) from piston (20).
- e. Remove retaining plate (26) and rod scraper (27).
- f. Insert work aid (figure 7-35) into piston (20, figure 7-34) and screw tool into piston lock (17). Tighten nut on work aid until piston lock bottoms in piston (20). Remove piston (20), seal retainer (12),

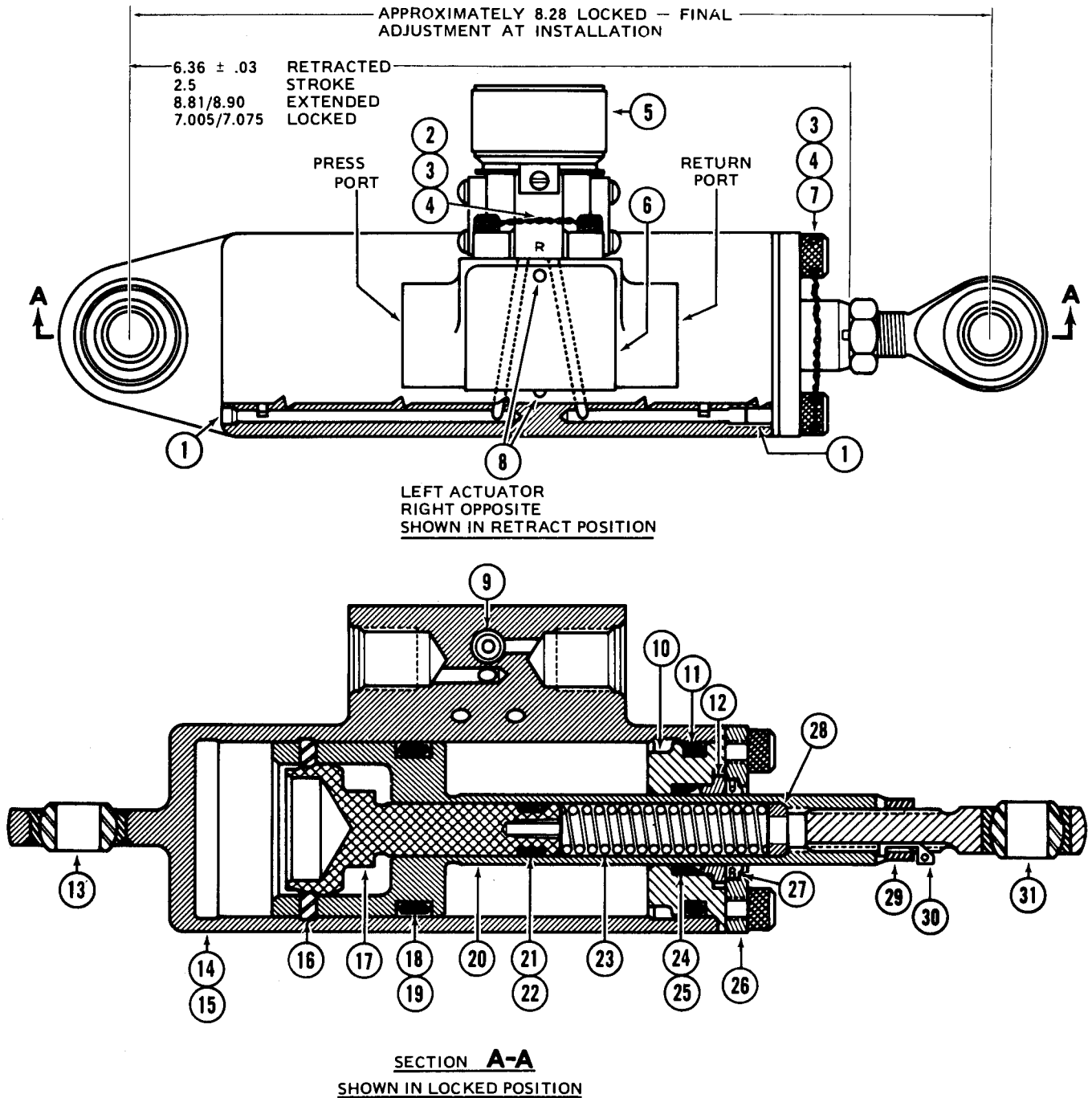

BHC P/N 209-076-035-1/2  
 DECOTO AIRCRAFT CO  
 P/N 2-7323-1/-2

ALL DIMENSIONS ARE IN INCHES UNLESS OTHERWISE NOTED.

209076-41-1A

Figure 7-34, Servo Actuator (Electrohydraulic) – Wing Pylon Armament (Sheet 1 of 2)

- |                   |                                 |                     |
|-------------------|---------------------------------|---------------------|
| 1. Permanent plug | 11. Packing                     | 21. Packing         |
| 2. Cap screw      | 12. Seal retainer               | 22. Backup ring     |
| 3. Aluminum seal  | 13. Spherical bearing           | 23. Spring          |
| 4. Lockwire       | 14. Body assembly, LH shown     | 24. Foot seal       |
| 5. Servo valve    | 15. Body assembly, RH not shown | 25. Packing         |
| 6. Nameplate      | 16. Lock ring                   | 26. Retaining plate |
| 7. Cap screw      | 17. Piston lock                 | 27. Rod scraper     |
| 8. Drive screw    | 18. Packing                     | 28. Spring seat     |
| 9. Check valve    | 19. Channel seal                | 29. Jam nut         |
| 10. Rod bearing   | 20. Piston                      | 30. Locking key     |
|                   |                                 | 31. Bearing         |

209076-41-2B

**Figure 7-34. Servo Actuator (Electrohydraulic) – Wing Pylon Armament (Sheet 2 of 2)**

foot seal (24), packing (25) and rod bearing (10) from body assembly (14 or 15) as a group.

**g.** Remove seal retainer (12), foot seal (24) and packing (25) from piston (20).

**h.** Remove rod bearing (10) from piston (20).

**i.** Loosen nut on work aid until free. Remove work aid.

**j.** Remove piston lock (17), spring (23), and spring set (28) from piston (20).

**k.** Do not remove lock ring (16) from piston (20) unless damage is evident.

**l.** Remove packing (11) from rod bearing (10).

**m.** Remove packing (21) and (backup) rings (22) from piston lock (17).

**n.** Remove packing (18) and channel seal (19) from piston (20).

**7-130. P CLEANING – SERVO ACTUATOR (ELECTROHYDRAULIC) – ARMAMENT WING PYLON.**



**Cleaning solvent is flammable and toxic. Provide adequate ventilation. Avoid prolonged breathing of solvent vapors and contact with skin or eyes.**

**a.** Clean external surfaces, except polished surfaces of piston rod by wiping with a cloth moistened with solvent (C112).

**b.** Carefully clean exposed polished surfaces of piston rod with a cloth moistened with hydraulic fluid (C61 or C62).

**7-131. P INSPECTION – SERVO ACTUATOR (ELECTROHYDRAULIC) – ARMAMENT WING PYLON.**

**a.** Inspect spherical bearings (13 and 31, figure 7-34) for roughness when rotated by hand and for secure installation. Damage and/or loosely installed bearings are not acceptable.

**b.** Inspect valve body (14 and 15) for nicks, scratches, dents, and gouges, minor damage is acceptable if polished out and depth after clean up does not exceed **0.020** inch.

**c.** Inspect valve body (14 and 15) for corrosion, minor corrosion damage is acceptable if polished out to twice the depth of the corrosion and depth after clean up does not exceed **0.020** inch.

**d.** Inspect boss of servo valve (5) for nicks, scratches, dents and gouges, minor damage is acceptable if polished out and depth after repair does not exceed **0.032** inch.

**e.** Inspect boss of servo valve boss (5) for corrosion. minor corrosion damage is acceptable if polished out to twice the depths of the corrosion and depth after repair does not exceed **0.032** inch.

**f.** Inspect exposed surface of piston (20) for scratches, dents and nicks. Minor damage is

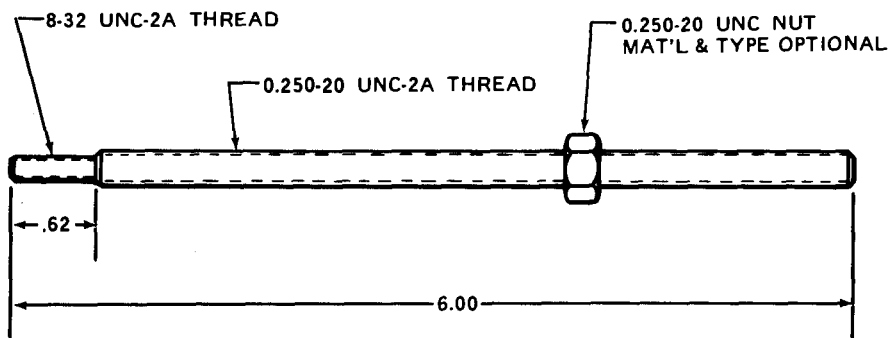

ALL DIMENSIONS ARE IN INCHES UNLESS OTHERWISE NOTED.

209076-34A

Figure 7-35. Work Aid for Wing Pylon Armament Servo Actuator Disassembly/Assembly

acceptable if polished out and minimum piston rod diameter after polishing out is not less than **0.621** inch.

**g.** Inspect threaded areas for damage to threads. Maximum acceptable damage is:

- (1) **one-third** of thread depth
- (2) **0.125** inch in length
- (3) maximum number of damaged threads is two.

**h.** Inspect for residue around rod of piston (20). Black residue in this area is acceptable.

**7-132. P REPAIR AND REPLACEMENT – SERVO ACTUATOR (ELECTROHYDRAULIC) – ARMAMENT WING PYLON (AVIM).**

**a.** Replace spherical bearings (13 and 31, figure 7-34) which fail to meet inspection requirements of paragraph 7-131.

**b.** Replace servo actuator if mechanical and/or corrosion damage on valve body or servo valve boss exceeds the limits noted in paragraph 7-131.

**WARNING**

Cleaning solvent is flammable and toxic. Provide adequate ventilation, Avoid prolonged breathing of solvent vapors and contact with skin or eyes.

**c.** Polish out mechanical and/or corrosion damage on valve body and servo valve boss which is within limits noted in paragraph 7-128. Use 600 grit sandpaper (C102) and polish to original finish. Clean polished area with solvent (C112). Treat polished area with chemical film (C31). Touch up repair area with primer (C88 or C91).

**d.** Polish out mechanical damage on piston rod which is within limits noted in paragraph 7-128. Use crocus cloth (C37) or fine India stone (C116). Clean repaired area with a clean cloth dampened with hydraulic fluid (C61 or C62).

**e.** Clean up damage on threads which is within limits noted in paragraph 7-131.

**f.** Replace ail packings when fluid leakage or damage necessitates disassembly of servo actuator.

**7-133. P ASSEMBLY ASSEMBLY – SERVO ACTUATOR (ELECTROHYDRAULIC) – ARMAMENT WING PYLON. (AVIM)**

**a.** Lubricate all packing channel seal and foot seal with hydraulic fluid (C61 or C62).

**b.** Install packing (18, figure 7-34) into channel seal (19).

**NOTE**

Installation may be aided by heating channel seal and packing with a heat lamp; however, heating is not mandatory.

c. Install packing (18) and channel seal (19) in piston (20) with a conical sleeve type work aid. See figure 7-36 for instructions to fabricate work aid.

d. Install packing (25, figure 7-36) onto rod bearing (10).

e. Install packing (21) and channel seal (19) onto piston lock (17).

f. If lock ring (16) was removed at disassembly, install lock ring (16) onto piston (20).

**NOTE**

**Install lock ring with chamfer on inside diameter toward channel seal in piston.**

g. Install spring seat (28) and spring (23) onto piston (20).

h. Insert piston lock (17) into piston (20) until both ends are flush. While holding the piston lock in this position, insert work aid (figure 7-35) into piston lock and tighten nut until piston lock bottoms in piston. When the piston lock bottoms in piston, the lock ring should be fully contracted in the piston.

i. Install piston (20, figure 7-34) into body assembly (14 and 15) approximately halfway down. Remove work aid.

j. Install packing (25) onto foot seal (24).

k. Install rod bearing (10) into body assembly (14 or 15).

l. Install foot seal and packing onto piston (20). Push foot seal and packing into cavity in rod bearing.

m. Install seal retainer (12) onto piston (20) and push into foot seal cavity.

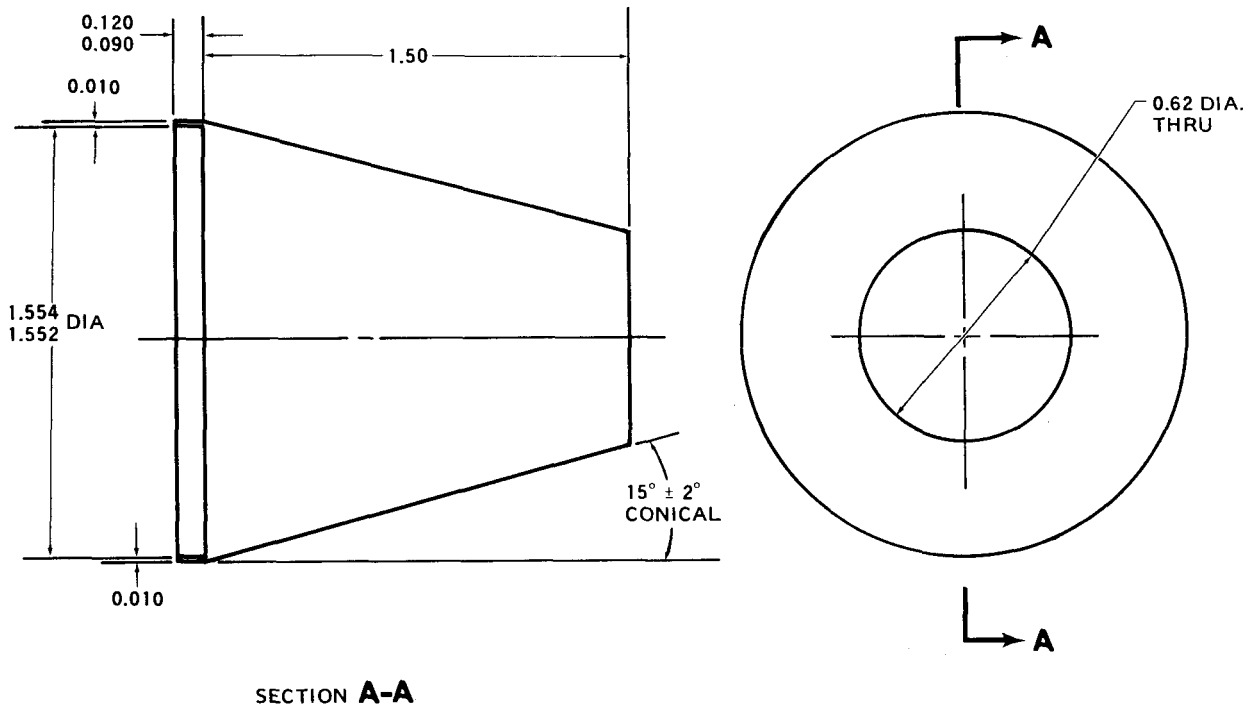

Make seal installation tool from aluminum alloy

ALL DIMENSIONS ARE IN INCHES UNLESS OTHERWISE NOTED.

209001-68A

Figure 7-36. Work Aid For Seal Installation on Wing Pylon Armament Servo Actuator

- n. Install rod scraper (27) onto piston (20).
- o. Install retaining plate (26) onto piston (20). Position area of plate without tapped hole toward return fluid port.
- p. Install cap screws (7) through retaining plate (26) and into body assembly (14 or 15). Torque cap screws **50 TO 60** inch-pounds. Secure with lockwire (C138).
- q. Install jamnut (29) and locking key (30) onto bearing (31).
- r. Install bearing (31) into piston (20).

**NOTE**

**A test sheet (figure 7-37) is provided for recording test data while performing test functions of the armament pylon servo actuator P/N 209-076-035 (Vendor No. 2-7323).**

**7-134. P FUNCTIONAL TEST – SERVO ACTUATOR (ELECTROHYDRAULIC) – ARMAMENT WING PYLON. (AVIM)**

- a. Install servo actuator that is to be tested as shown in figure 7-38.
- b. Apply a pressure of **1500** psig to the PRESSURE port and cycle the servo actuator until all air is bled.
- c. Maintain **1500** psig pressure and proceed to step d.
- d. Apply a differential current of **5** ma to extend the servo actuator and then to retract. The servo actuator must move to its full stroke position in the proper direction.

**7-135. P LOCK PRESSURE TEST – SERVO ACTUATOR (ELECTROHYDRAULIC) – ARMAMENT WING PYLON. (AVIM)**

- a. Apply **1500** psig to the PRESSURE port and move servo actuator to its retracted position.
- b. Reduce pressure to **250** psig and slowly extend servo actuator until the locked position is reached.
- c. If servo actuator does not lock, reduce pressure **5** psig and repeat test.

d. If necessary, continue reducing pressure by 5 pound increments and repeating lock test. The servo actuator must lock at a pressure of **100 TO 250** psig.

e. Record the pressure at which the servo actuator locks.

**7-136. P UNLOCK UNLOCK PRESSURE TEST – SERVO ACTUATOR (ELECTROHYDRAULIC) – ARMAMENT WING PYLON. (AVIM)**

a. With servo actuator in the locked condition, apply an extend signal and slowly increase pressure at PRESSURE port until servo actuator unlocks.

b. Record the unlock pressure.

c. Rotate piston rod **90** degrees and repeat test.

d. Make ten unlock tests.

e. Rotate piston rod **90** degrees each time. The unlock pressure must be **100 TO 250** psig.

**7-137. P BACKLASH TEST – SERVO ACTUATOR (ELECTROHYDRAULIC) – ARMAMENT WING PYLON. (AVIM)**

a. Install servo actuator in Part Number E.D.0889 (75) test fixture as shown in figure 7-39.

b. Apply a **200** pound tension load and then a **200** pound compression load on servo actuator piston rod.

c. Measure total free play and record. Maximum permissible free play is **0.017** inch.

**7-138. P PROOF PRESSURE TEST – SERVO ACTUATOR (ELECTROHYDRAULIC) – ARMAMENT WING PYLON. (AVIM)**

a. Set servo actuator to its mid-stroke position and block the RETURN port.

b. Apply **2250** psig to PRESSURE port for **2** minutes.

c. Reduce pressure to **5** psig for **2** minutes.

d. Check for evidence of external leakage, loosening, permanent deformation and rupture of parts.



WORK ORDER NO: \_\_\_\_\_

TEST SHEET

SERIAL NO.'s DA \_\_\_\_\_ THRU DA \_\_\_\_\_ FOR P/N 209-035-1 and -2  
(Vendor No. 2-7323-1, -2)

SERIAL NO.	WEIGHT	DIRECTION TEST A+, B-	LOCK PRESSURE TEST	UNLOCK PRESSURE TEST	BACKLASH TEST .017 MAX.	PROOF PRESS. TEST			EXTERNAL LEAKAGE 1 DROP/25 CYCLES @ 1500 PSIG	INTERNAL LEAKAGE 378 cc/mm MAX. @ 1500 PSIG
						PRESS.		RETURN		
						2250	5	1500		
		-1 RETRACT -2 EXTEND								

209076-50

Figure 7-37. Sheet For Recording Test Data For Wing Pylon Armament Servo Actuator

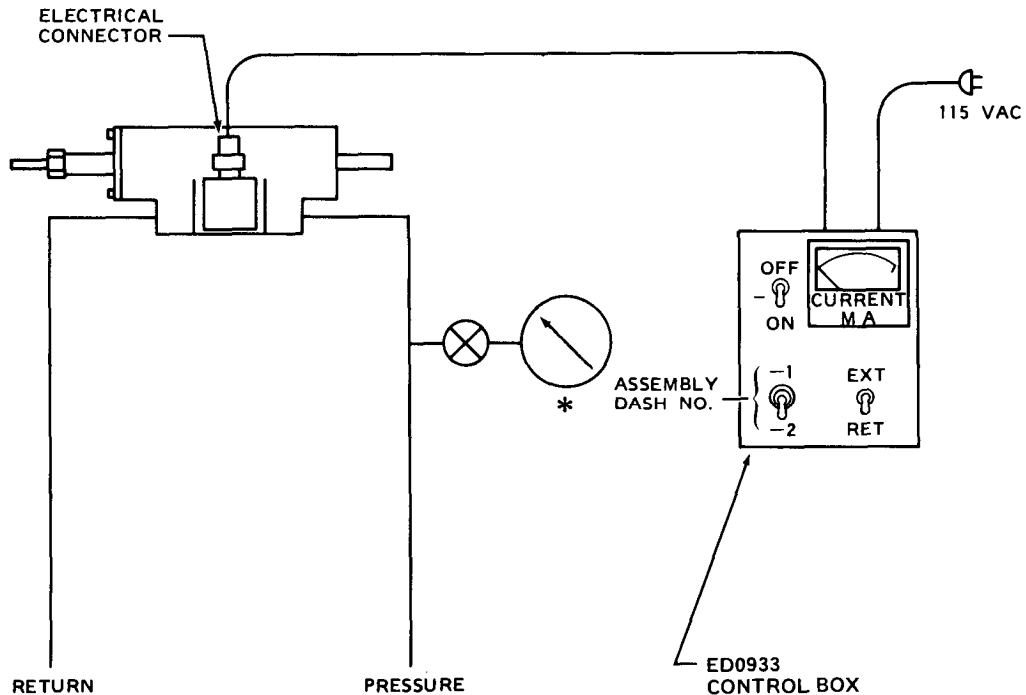

\* 0-2000 PSI GAUGE FOR OPERATION TEST, DIRECTION TEST, LEAKAGE TESTS  
 0-500 PSI GAUGE FOR LOCK AND UNLOCK TESTS

209076-42B

Figure 7-38. Schematic Diagram —Wing Pylon Armament Servo Actuator Connections For Bench Test

e. Record the results and if any of these discrepancies were noted, reject servo actuator.

f. Repeat proof pressure test with PRESSURE port blocked and 1500 psig applied to the RETURN port.

g. Inspect for leaks, distortion, etc., as listed above. Record results.

**7-139. P LEAKAGE TESTS – SERVO ACTUATOR (ELECTROHYDRAULIC) – ARMAMENT WING PYLON. (AVIM)**

a. Hookup servo actuator as shown in figure 7-38 and apply 1500 psig to the PRESSURE port.

b. Cycle servo actuator through 25 complete cycles.

c. Check leakage at rod seal and record. Maximum allowable leakage is one drop in 25 cycles.

**7-140. P INTERNAL LEAKAGE TESTS – SERVO ACTUATOR (ELECTROHYDRAULIC) – ARMAMENT WING PYLON. (AVIM)**

a. Disconnect electrical connector from the servo actuator.

b. Apply 1500 psig to the PRESSURE port.

c. Attach a filled drip spout to RETURN port. Measure and record amount of leakage at RETURN port for 1 minute. Maximum allowable leakage is 37.8 cubic centimeters.

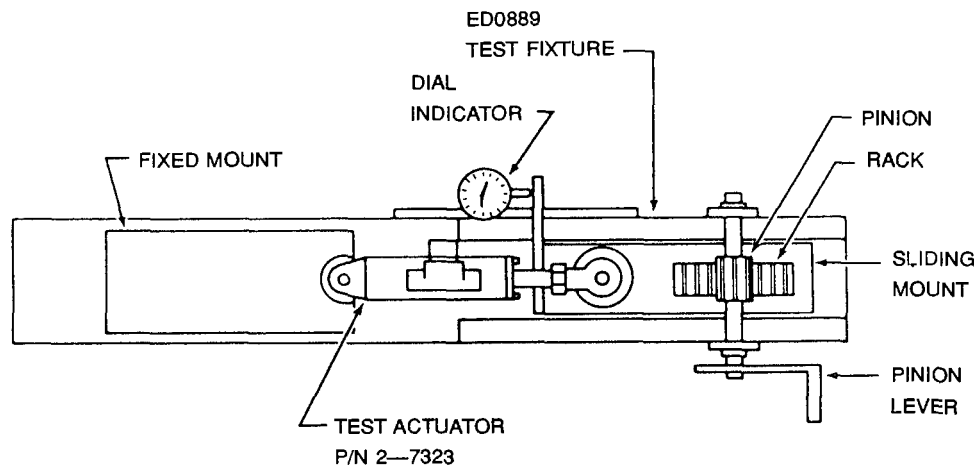

209076-43B

Figure 7-39. Tool Application—Wing Pylon Armament Servo Actuator Test Fixture

#### 7-141. **P** SERVO VALVE FREQUENCY RESPONSE—SERVO ACTUATOR (ELECTRO-HYDRAULIC)—ARMAMENT WING PYLON. (AVIM)

a. Attach copies of the frequency response characteristics, that are delivered with each servo valve, to the test results recorded in the preceding paragraphs.

b. The servo valve frequency response must not have resonance below 160 Hz.

c. The amplitude ratio must not be down less than 3 dB at 100 Hz and the phase lag must be less than 55 degrees at 100 Hz.

d. After completion of the test, unlock the servo actuator and move the piston rod to its retracted position. Plug the PRESSURE and RETURN ports. Wipe off all hydraulic fluid.

e. If the servo actuator is not to be installed immediately, package in an individual container that will provide adequate protection.

#### 7-142. **P** INSTALLATION—SERVO ACTUATOR (ELECTROHYDRAULIC)—ARMAMENT WING PYLON.

a. If servo actuator is being replaced, install adapting parts from old actuator.

#### NOTE

The servo actuator is factory adjusted and calibrated for proper length. Adjustment of the actuator will be accomplished during final alignment and boresighting of the system.

b. Install servo actuator on rack assembly and secure with attaching bolts, nuts, and washers. Torque (top) bolt EWSB-22-6-14 and (lower) bolt EWSB22-6-16 to 5 inch-pounds maximum.

c. Connect electrical connector to servo actuator.

#### WARNING

Missile launcher must be unloaded prior to functional check of servo actuators.

d. Connect hydraulic lines to servo actuator, bleed hydraulic system and functionally check elevation of ejector rack. Refer to TM 55-1520-236-10 and paragraph 7-3.

#### 7-143. **P** HYDRAULIC LINE FABRICATION. (AVIM)

Refer to Appendix D.

**7-144. E M HYDRAULIC SYSTEM**

**NOTE**

Refer to paragraph 7-2 for description of hydraulic system for helicopters coded **P**.

**7-145. E M DESCRIPTION – HYDRAULIC SYSTEM**

**NOTE**

The hydraulic systems for helicopters coded **E** are identical to the hydraulic systems for helicopters coded **M** except that helicopters coded **M** have a one way check valve (45, figure 7-40) installed. The check valve serves to prevent the electric hydraulic pump from cycling on and off excessively.

a. Two similar but separate hydraulic systems are used to operate flight controls power cylinders, stability and control augmentation system (SCAS) servo-actuators, and the M65 TOW missile launcher actuator. A schematic diagram of the hydraulic system for helicopters coded **E** and helicopters coded **M** is shown on figure FO-2. (foldout page FO-2). Systems No. 1 and No. 2 are exactly alike as to their reservoirs, transmission driven pumps, and module assemblies which contain system filters, solenoid valves, relief valves and pressure switches for the caution panel. Although both systems operate three dual servo hydraulic cylinders in main rotor controls there is not connection between systems because they use separate passages and piston chambers inside each dual cylinder and valve assembly. Both systems and an emergency system also have other hydraulic circuits and functions different and separate from each other.

b. An emergency system is provided to enable the pilot to execute a landing in the event that pressure is lost in both System No. 1 and System No. 2. The emergency system consists basically of a pressurized lockout valve, a pressure operated shutoff valve, solenoid operated shutoff valve, and check valves. See schematic diagram figure FO-2 (foldout page FO-2). If the pressure in hydraulic System No. 1 should fall to 650 psig for any reason, the pressurized lockout valve will close locking 650 psig on both pressure and return sides of the servo-actuators. This is done to ensure that the actuators remain full of oil

and free of air. A small accumulator, 1.0 cubic inch, is connected to the pressurized lockout valve to make up normal leakage of the cyclic actuators and to help maintain the 650 psig trapped in the actuators. The pilot can then move the flight controls by engaging the mechanical stops on the servo-actuators and moving the cylinders through direct mechanical coupling and internal irreversible valves. When the pilot moves the servo-actuator with no hydraulic pressure available, the fluid is moved from one side of the actuator to the other through flow passages in the actuator head. When the feed-back forces exceed the pressure setting of a differential relief valve, the valve will open, allowing a slight amount of fluid bypass through the actuator pressure to the return actuator passages. This will warn the pilot of an overloading condition.

c. An emergency system is provided to furnish hydraulic power to the collective hydraulic cylinder when pressure is lost in System No. 1 and System No. 2. The emergency system consists basically of an electric motor driven pump, reservoir, solenoid valves, filter, check valves, and pressure switch. The system is also used to power the wing pylon armament systems for boresight capability without the hydraulic test stand. The description of the emergency system in paragraph b is applicable to the cyclic control hydraulic cylinders and to the collective control hydraulic cylinder except that when the emergency electric hydraulic pump switch is positioned to "emergency", hydraulic fluid under pressure will be supplied to the collective cylinder, The remainder of System No. 2 will be closed off by solenoid valves. The primary purpose of the emergency system is to ensure that hydraulic power is furnished to the collective hydraulic cylinder. The pilot cannot maintain collective control without hydraulic pressure at the collective hydraulic cylinder.

d. In the event of a dual hydraulic system and starter/generator failure, the emergency electrical system with a fully charged battery, is capable of supplying the essential bus loads for at least 17.8 minutes, with the emergency hydraulic pump being used during low speed flight prior to landing, and, during landing operations not to exceed 5 minutes.

**7-146. E M OPERATIONAL CHECK AND TESTING – HYDRAULIC SYSTEM.**

The following principles of operation of System No. 1, System No. 2, and emergency system informs the mechanic how each system functions prior to

**CAUTION**

All check valves, relief valves, and flow regulators must point in direction of fluid flow.

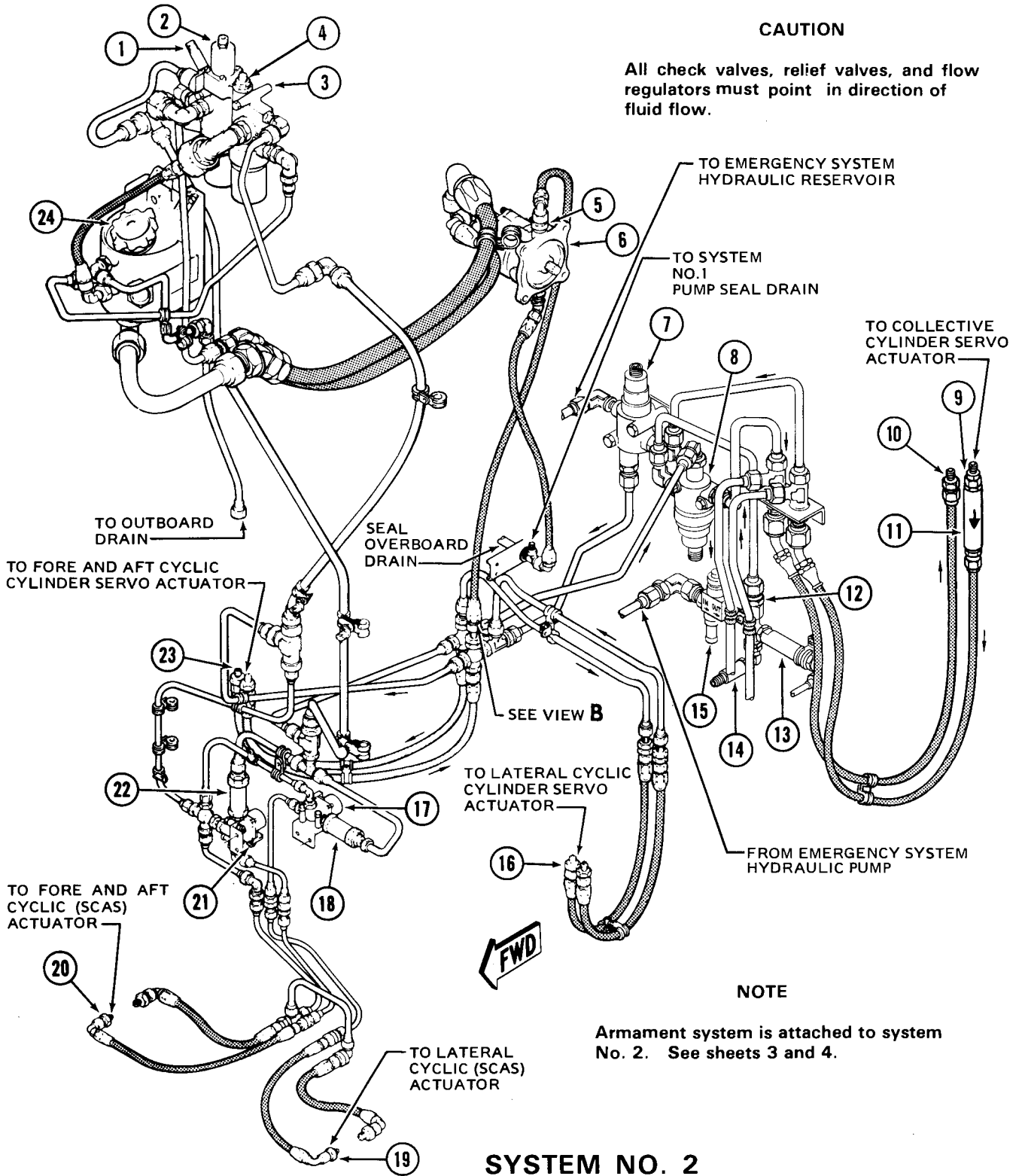

Figure 7-40. **E M** Hydraulic System (Sheet 1 of 5)

209076-60-1A

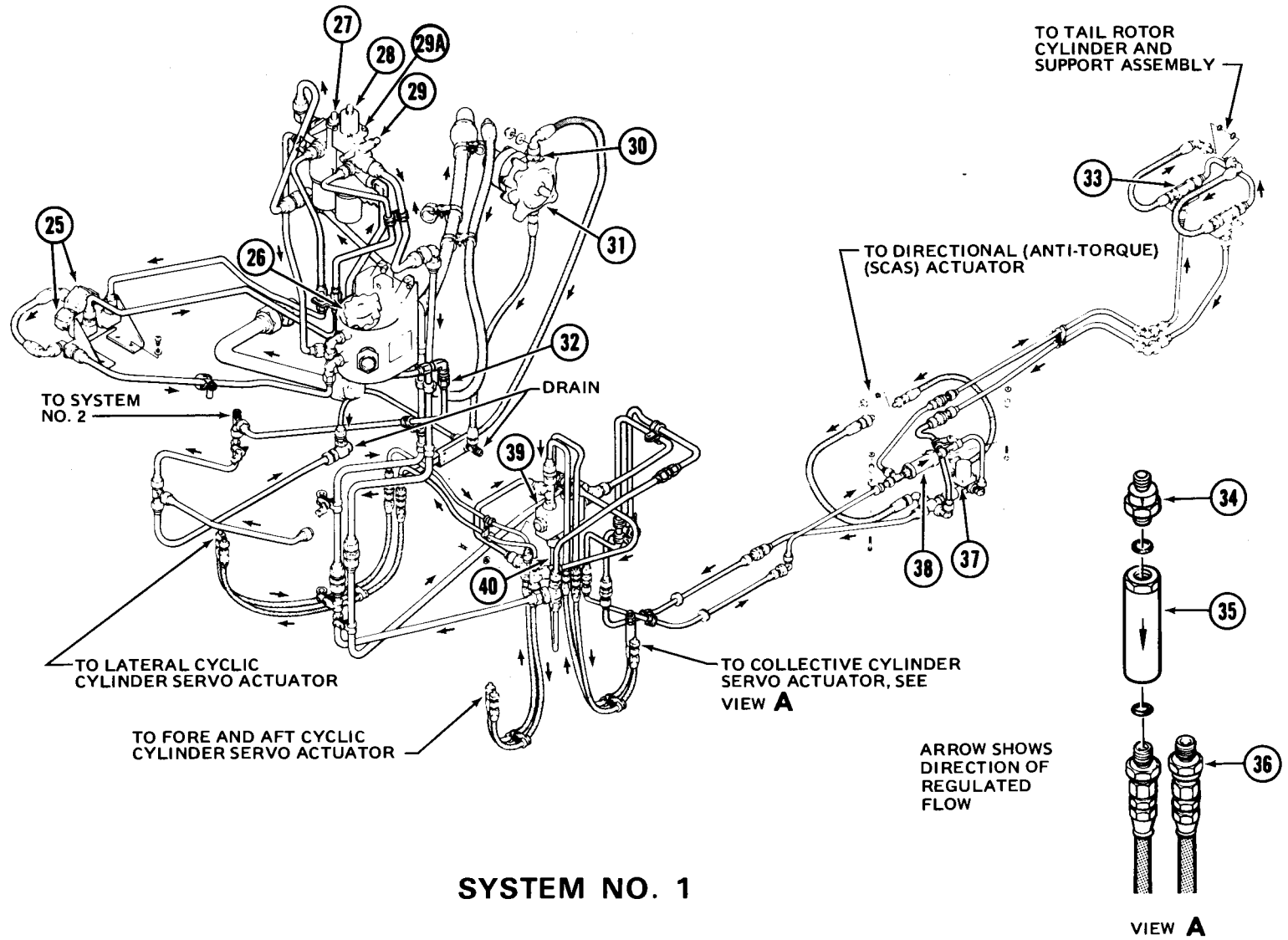
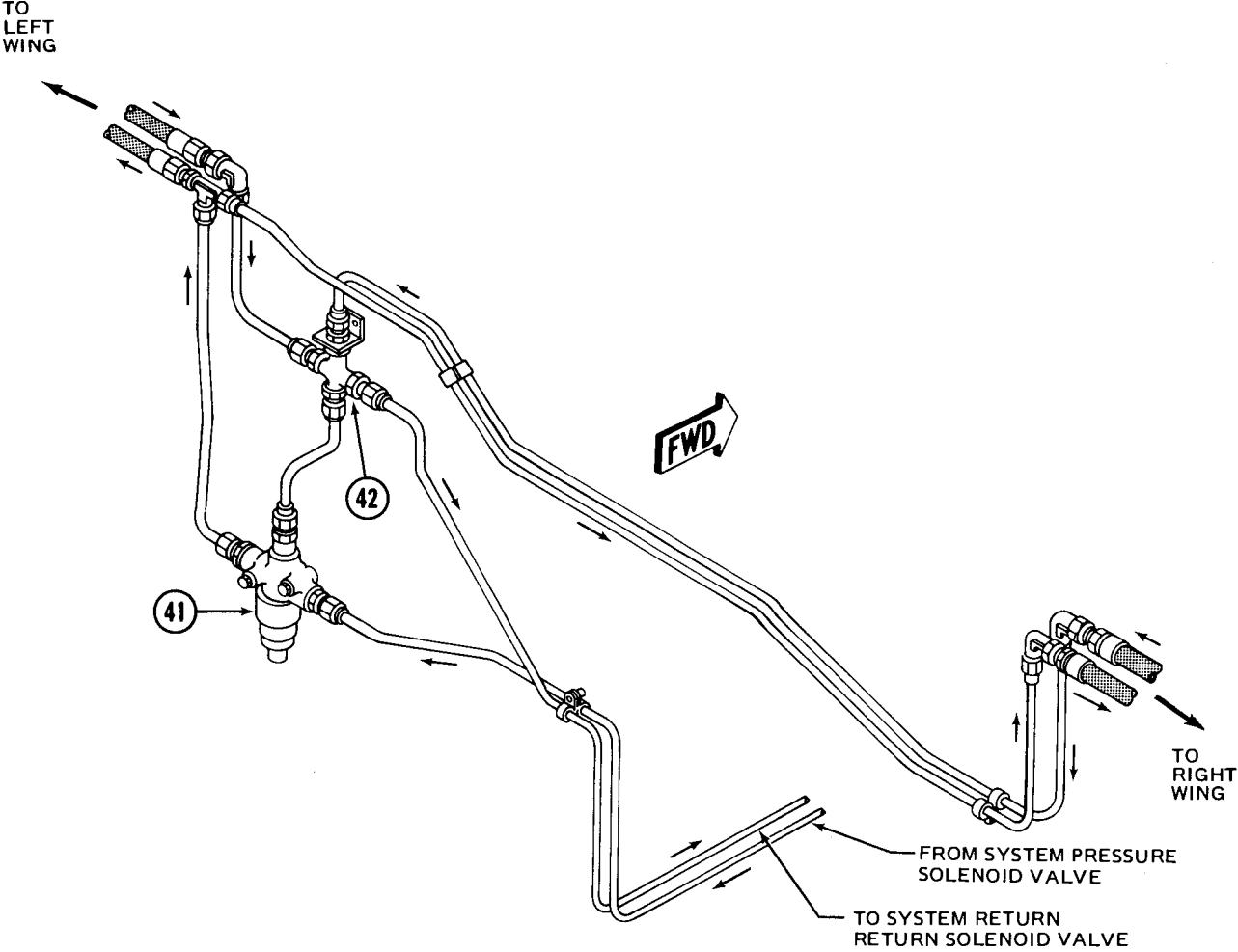
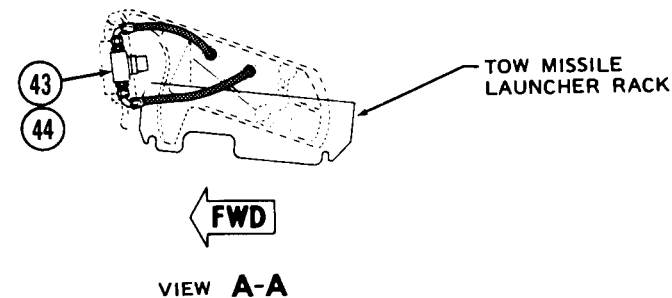
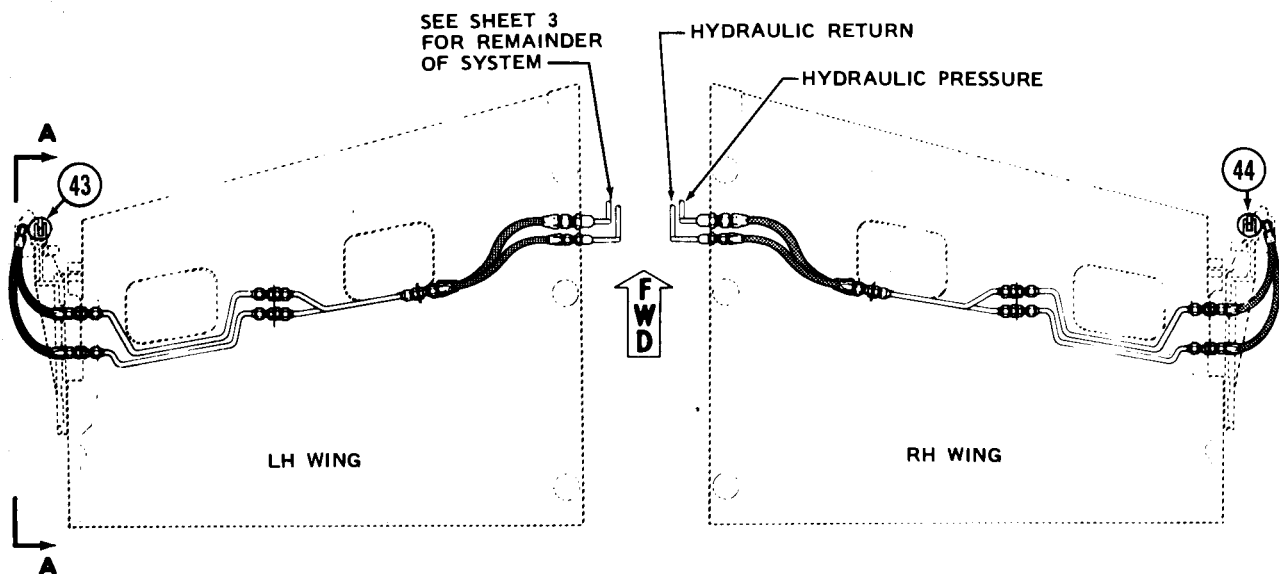

Figure 7-40. **E M** Hydraulic System (Sheet 2 of 5)



209076-60-3A

Figure 7-40. **E M** Hydraulic System (Sheet 3 of 5)



209076-29-2C

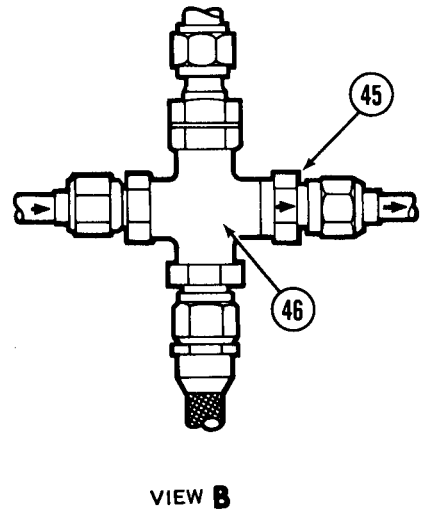

209076-67

Figure 7-40. **E M** Hydraulic System (Sheet 4 of 5)



1. Pressure switch
2. Solenoid valve (system 2) P/N 88604-1
3. Hydraulic Modular unit
4. Relief valve
5. Check valve
6. Pump
7. Solenoid valve P/N 204-076-504-3 FSCM 94641  
P/N 1-U-1025-63 or FSCM 16780 P/N 130027-5
8. Solenoid valve P/N 204-076-504-3 FSCM 94641  
P/N 1-U-1025-63 or FSCM 16780 P/N 130027-5
9. Relief valve
10. Check valve
11. Flow regulator
12. Check valve
13. Pressure relief valve
14. Pressure switch
15. Filter
16. Check valve
17. Solenoid valve (SCAS system)  
P/N 209-076-023-1 FSCM 16780 P/N 15353
18. Filter
19. Check valve
20. Check valve
21. Solenoid valve (SCAS system)  
P/N 209-076-023-1 FSCM 16780 P/N 15353
22. Filter
23. Check valve
24. Reservoir assembly
25. Test connectors
26. Reservoir assembly
27. Relief valve
28. Solenoid Valve (system 1)  
P/N 88604-1
29. Pressure switch
- 29A. Modular unit
30. Check valve
31. Pump
32. Check valve
33. Check valve
34. Relief valve
35. Flow regulator
36. Check valve
37. Solenoid valve (SCAS system)  
P/N 209-076-023-1 FSCM 16780 P/N 15353
38. Filter
39. Lockout valve
40. Accumulator assembly
41. Solenoid valve (armament)  
P/N 204-076-504-3 FSCM 94641  
P/N 1-U-1025-63 or FSCM 16780  
P/N 130027-5
42. Check valve
43. Servo actuator
44. Servo actuator
45. Check valve **M** only
46. Cross

209076-60-4B

Figure 7-40. **E M** Hydraulic System (Sheet 5 of 5)

performing testing and operational checks of hydraulic systems after maintenance requirements have been accomplished.

**a. Principles of Operation.** (typical for both systems). In normal operation of each system, hydraulic fluid is supplied from its nonpressurized reservoir by gravity feed and suction to a transmission-driven pump. The pump is a variable-displacement type with internal pressure compensation, preset to provide **1500** (plus or minus **25**) psi output pressure and **6.5** gpm flow rate at **4170** operating rpm according to system demands. Fluid bypassed in pump, to regulate pressure and flow, is released through a line to the return side of the hydraulic modular unit. Pump output is delivered into the hydraulic modular unit and passes through the pressure filter. A relief valve in the module guards the system against excessive pressure; relief valve is set to open at **1626 TO 2140** psi. The system solenoid valve is normally de-energized and open to the SYS PRESS outlet of the module but can be electrically energized to bypass position by placing the HYD TEST switch to position marked for opposite

system. A pressure switch will cause the caution panel to light if hydraulic modular unit outlet pressure decreases (at **600 TO 400** psi).

(1) Beyond the hydraulic modular unit, fluid under pressure is delivered through tubes and hoses to three dual hydraulic servo cylinders in main rotor cyclic and collective control systems. Fluid flows into and out of one functional half of each dual cylinder when its servo control valve is moved mechanically by linkage from a control stick, causing the cylinder piston rod to make corresponding movements of linkages to the main rotor. The cylinder valves also have internal functions which tend to prevent feedback of motion from the rotor to the control stick. Either system alone can operate the cylinders, but the dual (or tandem) arrangement is used for added safety of operation.

(2) Fluid is returned from power cylinder and other units through external lines to the SYS RET inlet of the hydraulic modular unit, to pass through the return filter. Normal return flow from hydraulic modular unit to reservoir is through a hose connected

on the quick-disconnect coupling which is at other times used to connect ground test equipment. However, if this hose has not been connected, a low pressure (45 psi) will open a relief valve and allow flow through another line from the hydraulic modular unit RES RET outlet to the reservoir BYPASS inlet.

(3) Both hydraulic modular units are equipped with quick-disconnect couplings to allow ground operation with a portable hydraulic test stand (S2). System operation with such a unit is the same as described for normal operation, except that the reservoir and transmission-driven pump are not being used. External dc power will also be required for electrically operated valves, caution panels, and electric driven hydraulic pump when engine is not operating.

b. Special Functions of System No. 1. In addition to typical operation described in preceding paragraphs for both systems, hydraulic System No. 1 has the following special functions.

(1) Tail rotor controls hydraulic cylinder. This is a single hydraulic cylinder and servo valve assembly, mechanically connected into control linkage to the tail rotor.

(2) Yaw stability and control augmentation system (SCAS) servo actuator. This circuit includes a pressure line filter, a three-way, two-position solenoid valve, and an electro-hydraulic servo actuator connected in the tail rotor control linkage.

c. Special Functions of System No. 2. In addition to typical operation described for both systems in paragraph 7-145, hydraulic System No. 2 has the following special functions:

(1) Pitch and roll stability and control augmentation system (SCAS) actuators. Circuits are provided for pitch and roll functions of stability augmentation system. Each of the two circuits includes a pressure line filter, a three-way, two-position solenoid valve, and an electro-hydraulic servo actuator connected into the fore-and-aft and lateral cyclic control linkage.

(2) Armament system hydraulic power provisions (figures 7-40, 7-41 and F02 (fold-out 2)). Hydraulic provisions for left and right M65 TOW missile launchers ejector racks are installed. This circuit provides pressure and return hydraulic lines to a hydraulic servo actuator mounted on each of the TOW missile launcher racks. The MASTER ARM

switch controls the M65 TOW missile launcher rack hydraulic servo actuator ON-OFF solenoid valve. The three-way, two-position solenoid valve can be de-energized (turned off) by the gunners pilot override switch.



**Ensure that fluid in hydraulic test stand is the same type fluid as in the helicopter.**

d. Ground Testing of Hydraulic Systems with Hydraulic Test Stand (S2). The following ground operational check of the three hydraulic systems is to aid in troubleshooting table 7-9 or test for proper functioning of each system after maintenance. Whenever possible, hydraulic systems should be pressurized simultaneously to avoid introducing air into the unpressurized system. When this is not possible, avoid rapid control movement when operating with a single pressurized system.

**Premaintenance Requirements for Testing Hydraulic System**

Condition	Requirements
Model	AH-IS
Part No. or Serial No.	All
Special Tools	None
Test Equipment	None
Support Equipment	(S1), (S2), (S10), (S12), (S13), (S26)
Minimum Personnel Required	Two
Consumable Materials	(C61), (C62)
Special Environmental Conditions	None

(1) Use hydraulic test stand (S2) or provide a similar hydraulic test stand conforming to the following requirements:

(a) Thoroughly clean, and service with prescribed hydraulic fluid (C61 or C62).

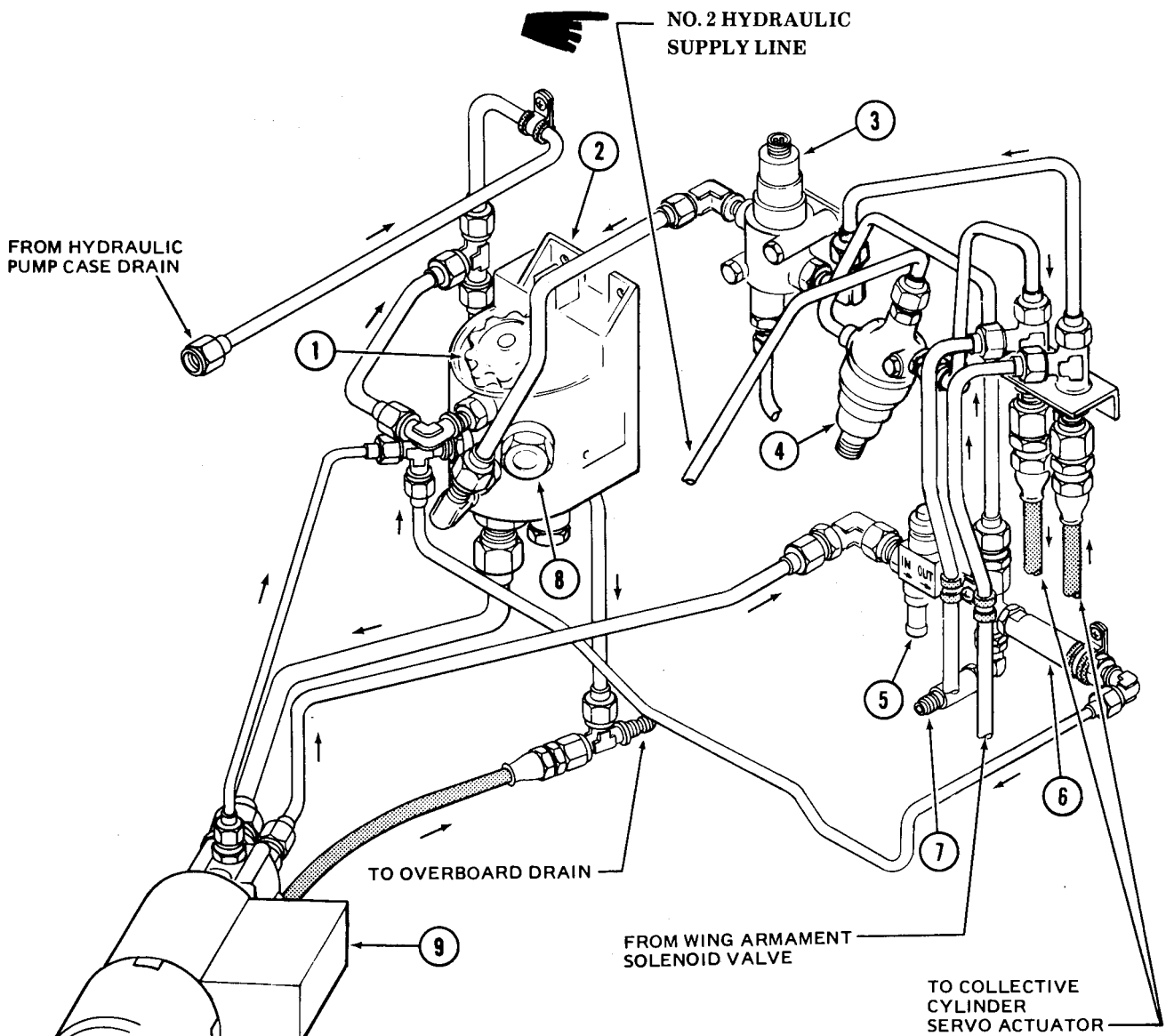

1. Filler cap
2. Reservoir assembly
3. Solenoid valve (system return)  
P/N 204-076-504-3 FSCM 94691  
P/N 1-U-1025-63 or FSCM 16780 P/N 130027-5
4. Solenoid valve (system pressure)  
P/N 204-076-504-3 FSCM 94641  
P/N 1-U-1025-63 or FSCM 16780 P/N 130027-5
5. Filter
6. Pressure relief valve
7. Pressure switch
8. Sight gage
9. Emergency hydraulic pump package

209076-69A

Figure 7-41. **EM** Emergency (Electric Motor Driven) Hydraulic System

(b) Equipped with **10** micron filter in pressure and return lines through which all fluid passes before leaving and returning to unit.

(c) Capable of **2300** psig pressure and at least **6** gpm flow rate.

(d) Having a calibrated pressure gage of **2500** psi minimum capacity.

(e) Pressure and return lines equipped to connect to both hydraulic systems for simultaneous operation.

(2) Visually inspect entire hydraulic system of helicopter to make sure all lines and components are secure and appear capable of operation. Obtain access as follows:

(a) Open left and right doors (11, figure 2-3).

(b) Open left and right transmission cowls (11). Place maintenance platforms (S10) in position on right and left side of helicopter.

(c) Remove left and right doors (17) attached with cowl fasteners directly below wings at both sides.

(d) Remove panel door, attached with cowl fasteners on right side of fuselage below tailpipe fairing, for access to tail rotor control power cylinder.

(e) Remove screw-mounted panels from sides of fuselage for access to lines leading to armament hydraulic connections and stability augmentation system actuators.

(f) Remove cowling from right and left TOW pylons for access to hydraulic cylinders.

(3) Prepare hydraulic test stand (S2) for operation. Pressure relief valve set for **2100** psig cracking pressure; pump set to provide at least **6** gpm flow; pressure compensation set at **1475 TO 1525 psig**.

(4) On each of two hydraulic modular units, located above reservoirs, prepare ground test couplings by removing cap from pressure coupling and disconnecting reservoir return hose from return coupling. Connect hydraulic test stand (S2) hoses to both hydraulic modular units.

**WARNING**

Verify that universal turret is unloaded.

**CAUTION**

Ensure main rotor tiedown is removed to minimize possible contact of main rotor hub components with each other in extreme positions during ground operation with external power.

(5) Remove main rotor tie-down. Apply **28** volt dc electrical auxiliary power unit (S12) to external power receptacle at left side of fuselage. On pilot console, set switches to activate both hydraulic systems, armament system, and stability augmentation system.

(6) Operate hydraulic test stand (S2) applying pressure (**1475 TO 1525** psig) to hydraulic systems for at least **15** minutes. During this time, perform the following:

(a) Observe all parts of systems for evidence of leakage, taking corrective action as necessary. See table 7-1 for maximum allowable leakage.

(b) Slowly cycle all controls to limits of stroke, observing movement of hydraulic power cylinders. Check that all moving parts have clearance so that there is no fouling or binding. Give particular attention to flexible connections, to make sure hoses are not pinched and that vibration does not tend to loosen fittings.

(c) Work out air from systems by actuating cyclic stick, collective stick, and tail rotor control pedals through at least ten full strokes. Some chatter in tail rotor controls is normal with hydraulic test stand (S2). If air is eliminated satisfactorily, proceed to step e. If air is not eliminated, accomplish step (d).

(d) When air is not removed by accomplishing procedures in step (c), perform the following:

1. Disconnect collective cylinder (5, figure 7-3) from collective lever (4).

2. Disconnect fore and aft cyclic cylinder (17) from swashplate (3).

**3.** Disconnect lateral cyclic cylinder (9) from swashplate (3).

**4.** Disconnect control tube (22) from bellcrank at lower end.

**5.** Disconnect control tube (7) from bellcrank at lower end.

**6.** Disconnect control tube (6) from bellcrank at lower end.



**Ensure that upper ends of cylinders (5, 17 and 9) will not strike any object when moved through full throw during accomplishment of following steps.**

**7.** Check hydraulic test stand (S2) to ensure it is operating as described in step (6).

**8.** Push up on fore and aft cyclic control tube (22) and hold until cylinder (17) moves through full throw. Pull down on tube (22) until cylinder (17) moves through full throw. Repeat through ten full Strokes.

**9.** Move cylinder (5) and cylinder (9) through ten full strokes by same procedure outlined in step **8**.

**10.** Connect control tube (22) to bellcrank at lower end.

**11.** Connect control tube (7) to bellcrank at lower end.

**12.** Connect control tube (6) to bellcrank at lower end.

**13.** Connect collective cylinder (5) to collective lever (4).

**14.** Connect fore and aft cyclic cylinder (17) to swashplate (3).

**15.** Connect lateral cyclic cylinder (9) to swashplate (3).

**e.** Reduce pressure in both systems to **0** psig.

**(8)** Check operation of caution panel circuits as follows:

**(a)** Energize electrical system.

**(b)** Close CAUTION LTS circuit breakers.

**(c)** With test unit pressure reduced to **0** psig, cycle controls to lose residual pressure. Pilot #1 HYD PRESS, pilot #2 HYD PRESS, gunner #1 HYD PRESS, and gunner #2 HYD PRESS caution panel worded segments should be illuminated.

**(d)** With external hydraulic power applied, slowly increase test unit pressure. Pilot #1 HYD PRESS, pilot #2 HYD PRESS, gunner #1 HYD PRESS, and gunner #2 HYD PRESS caution panel worded segments should extinguish at **700 TO 900** psig.

**(e)** Slowly reduce pressure. Pilot #1 HYD PRESS, pilot #2 HYD PRESS, gunner #1 HYD PRESS, and gunner #2 HYD PRESS caution panel worded segments should illuminate at **600 TO 400** PSIG.

**(9)** Check operation of single systems as follows:

**(a)** Close HYD CONTR and CAUTION LTS circuit breakers.

**(b)** Apply external hydraulic test stand (S2) pressure to System No. 1 and System No. 2 test connectors.

**(c)** Energize electrical system.

**(d)** While operating hydraulic test stand (S2) at **1475 TO 1525** psig pressure, place HYD TEST switch (located on console) to SYS 1. Pilot #2 HYD PRESS and gunner #2 HYD PRESS caution panel worded segments should be illuminated. Pilot #1 HYD PRESS and gunner #1 HYD PRESS caution panel worded segments should be extinguished.

**(e)** Operate cyclic, collective and tail rotor controls checking for smooth and positive response.

**(f)** On console, place HYD TEST switch to SYS 2. Pilot NO. 1 HYD PRESS, and gunner HYD #1 caution panel worded segments should illuminate. Pilot NO. 2 HYD PRESS and gunner HYD #2 PRESS caution panel worded segments should be extinguished. Operate cyclic and collective controls, and check for smooth and positive response.

**NOTE**

**System No. 2 does not provide boost power for tail rotor controls.**

(g) Operate tail rotor controls. Tail rotor controls will lack hydraulic power, and should require more force than in normal operation.

(h) Release HYD TEST switch.

**NOTE**

**Continued operation of the cyclic actuator on System No. 1 (with System No. 2 unpressurized), could result in the hydraulic fluid being evacuated from the System No. 2 cylinders. This fluid will be displaced to the System No. 2 reservoir which could overflow. On engine start and operation of flight controls, fluid will return to system No. 2 cylinders.**

(i) Decrease hydraulic test stand (S12) pressure to 0 psig.

(j) Shut down and disconnect electrical auxiliary power unit (S12) from helicopter.

(10) Check emergency hydraulic system as follows:

(a) Check emergency hydraulic system reservoir, located in right side of fuselage, under wing, for proper fluid level.

(b) Using electrical auxiliary power unit (S12) engage EMERG HYD PUMP circuit breaker.

(c) Position pilot or gunner EMER HYDR PUMP switch to BORESIGHT. Pilot and gunner green EMERG HYDR PUMP ON caution panel worded segments should illuminate.

(d) Check that collective cylinder is powered.

(e) Engage WING PYLON switch and check that the wing pylon actuators are powered.

(f) Turn all switches to the OFF position and check that the collective actuator is not powered. Pilot and gunner green EMERG HYD PUMP ON caution panel worded segments should extinguish.

**NOTE**

**Refer to table 7-12 for emergency hydraulic system operational switching sequence.**

(g) position pilot or gunner EMER HYDR PUMP switch to EMER. Pilot and gunner green EMERG HYD PUMP ON caution panel worded segments should illuminate. Check that collective actuator is powered and wing pylons are not powered.

(h) Remove filter bowls, drain fluid and check filters for contamination. Replace filter if required. Torque filter bowls **100 TO 140 inch** pounds and secure with lockwire (C137).

(i) Apply **1000** psig to both systems and bleed air from the systems by cycling all controls through full travel a minimum of ten cycles.

(j) Reduce pressure in both systems to **0** psig. Shut down hydraulic test stand (S2).

(11) Test hydraulic relief valves as follows:

(a) Disconnect System No. 2 from test unit.

(b) Slowly increase System No. 1 pressure until relief valve (located on module unit) opens. Check that relief valve opens between **1626** and **2140** psig.

(c) Reconnect System No. 2 and disconnect System No. 1 from the hydraulic test stand (S2).

(d) Repeat test procedures outlined in preceding sub-step (b) for System No. 2.

(e) Reduce pressure in both Systems No. 1 and No. 2 to **0** psig. Shut down (S2) hydraulic test stand.

(12) Using hydraulic fluid dispenser (S1), fill reservoirs with clean hydraulic fluid (C61 or C62).

(13) Perform operational checks of armament hydraulics system in accordance with applicable instructions outlined in the following step e and TM 55-1520-236-10.

(14) Check filter bypass indicators on each hydraulic system module. Replace filters as required. After replacing any filters, operate hydraulic test

stand (S2) to check for leaks (refer to table 7-1) and replenish fluid in system.

**NOTE**

**Before shut-down of operation on hydraulic test stand (S2), center cyclic and place collective stick full down.**

(15) Disconnect electrical auxiliary power unit (S12) from helicopter. Shut down hydraulic test stand (S2) and disconnect hoses from couplings on modules. Install caps on pressure test couplings. Connect hoses from reservoirs to return test couplings on modules.

(16) Install fuselage panels removed for access. Close cowling and compartment doors.

**e. Operation Check of Hydraulic Systems Utilizing Helicopter Power.** Perform ground runup operational check of hydraulic Systems No. 1 and No. 2 and emergency hydraulic system as follows:

**(1) Pretest procedure.**

(a) Check hydraulic reservoir for proper fluid level. If required, using hydraulic fluid dispenser(SI), fill reservoir with hydraulic fluid (C62 or C63) (paragraph 7-6).

(b) Check all ground test connections for replacement of dust caps.

(c) Connect a **0 TO 3000** psig calibrated gage (S17) to each system at the pressure ground test fittings.

**(2) Test.** Utilizing helicopter power (TM 55-1520-236-10), perform the following:

(a) With the cyclic, collective, and directional controls stationary, run-up helicopter power until main rotor is turning at **88 TO 98** percent.

(b) Check pressure in both hydraulic Systems No. 1 and No. 2 Pressure should be **1475 TO 1525** psig.

(c) Shut down engine (TM 1520-236-10).

(d) Remove hydraulic pressure gage (S17).

**NOTE**

Refer to Note 7 of Table 7-1.

(3) **Wing pylons.** Functional check wing pylon actuators in accordance with procedures outlines in TM 55-1520-236-10.

(4) **Operational check of emergency hydraulic system.** Perform operational check of emergency hydraulic system as follows:

(a) Run up helicopter (TM 55-1520-236-10).

(b) With the engine running at flight idle, position HYD TEST switch to SYS 1. Pilot No. 2 HYDR PRESS and gunner HYDR PRESS #2 caution panel worded segments should illuminate. Position pilot or gunner EMER HYDR PUMP switch to EMER. Pilot and gunner green EMER HYDR PUMP caution panel worded segments should illuminate.

(c) Position pilot and gunner EMER HYDR PUMP switches to OFF.

(d) Release HYD TEST switch.

(e) Shut down engine (TM 55-1520-236-10).

**NOTE**

Refer to Note 7 of Table 7-1.

**7-147. E M FLUSHING - HYDRAULIC SYSTEM.**

Prior to flushing the hydraulic system, functionally check the hydraulic test stand (S2) to ensure that it is operating properly. Install new and unused hydraulic filter elements in the test unit for maximum fluid filtration. Using hydraulic fluid dispenser (S1), fill the hydraulic reservoir to capacity with fresh, clean, hydraulic fluid (C62 or C63) Inspect pressure and return hoses to hydraulic test stand (S2) for cleanliness. The requirements and procedures for flushing the hydraulic system are as follows:

**NOTE**

Systems must be flushed individually at 1000 psi. Flushing is required only if system is rebuilt due to major damage or if fluid has become contaminated.

Table 7-12. **EM**ergency Hydraulic System Operational Switching Sequence

	Pilot # 2 HYDR PRESS and Gunner # 2	Wing Pylon Solenoid Valve Press	Emergency System Solenoid Valve Return	Emergency System Solenoid Valve Press	Emergency System Hydraulic Pump  Panel Worded	Pilot and Gunner green EMERG HYDR PUMP ON Caution  Segments
HYDR PRESS  Pilot and Gunner EMER HYDR PUMP Switch Positions		Caution Panel Worded Segments				
Switch in OFF Position with System No. 2 Operative	Off	On*	Off	Off	Off	Off
Switch in OFF Position with System No. 2 Non-Operative	On	Off	Off	Off	Off	Off
Switch in EMER Position with System No. 2 Operative	Off	On*	Off	Off	Off	Off
Switch in EMER Position with System No. 2 Non-Operative	On	Off	On	On	On	On
Switch in BORESIGHT Position with System No. 2 Non-Operative	On	On	On	On	On	On

**LEGEND**

On = Solenoid Valve Energized

\*On = Solenoid Valve Energized if Selected

NOTE: Hydraulic System No. 1 has no interconnect with electric-hydraulic emergency system.



**Premaintenance Requirements for Flushing of Hydraulic System**

Condition	Requirements
Model	AH-1S <b>E M</b>
Part No. or Serial No.	All
Special Tools	None
Test Equipment	MS21902D4 Unions (3) MS21916D5-4 Reducers (2) MS21902D6 Unions (5) T15051-8D Coupling Half (2)  0 to 3000 PSI Gages (2) HAC No. 3234306 Test Containers (2)
Support Equipment	(S1) (S2) (S10) (S12)
Minimum Personnel Required	Two
Consumable Materials	(C61) (C62) (C112) (C137)
Special Environmental Conditions	Dust Free Well ventilated area

**a. Test Equipment Requirements.** Test equipment shall consist of a thoroughly clean hydraulic test stand (S2) serviced with hydraulic fluid (C61 or C62) and as follows:

- (1) Be capable of producing pressures of **2300** psig with minimum flow rate of **6** gpm.
- (2) Include a calibrated pressure gage with a minimum capacity of **2500** psig.
- (3) Include a **10-micron** absolute metal filter in the pressure line and a **10-micron** absolute metal filter on the return line.

(4) Include provisions in the pressure and return lines for connecting both System No. 1 and System No. 2 for simultaneous operation.

**b.** Prepare and test hydraulic systems as follows:

**NOTE**

**Immediately after disconnecting hoses, cap cylinder ports to prevent contamination of system.**

(1) Disconnect hoses from cyclic and collective cylinders. Connect hose ends together with MS21902D4 and MS21902D6 unions.

(2) Disconnect hoses from tail rotor control cylinder and SCAS servo actuators in the lateral, fore and aft, and directional control systems. Connect hose ends together with MS21916D5-4 reducers.

(3) Disconnect hoses from left and right wing pylon servo actuators. Connect hose ends together with MS21902D6 unions.



**Use extreme caution in handling filter element to prevent contamination damage.**

(4) Remove filters and discard elements from four filter element bowls of hydraulic modular units (paragraph 7-46). Do not remove packings. Immediately after removing filter elements, reinstall bowls. Torque bowls **100 TO 140** inch-pounds.



**Both hydraulic Systems No. 1 and No. 2 cannot be flushed at the same time.**

(5) Connect hydraulic test stand (S2) to System No. 1 through ground test fittings (12, figure 7-1), (located on service deck on right side of helicopter inside access door).

(6) Make a thorough visual inspection of complete hydraulic system to ensure that all components and lines are securely attached and appear capable of satisfactory operation before continuing flushing.

(7) When performing the following steps, (9) through (14), observe all system lines and components for external leakage. Take appropriate action to correct any leakage before proceeding.

(8) Connect external 28 Vdc electrical auxiliary power unit (S12) to helicopter.

(9) Energize HYDR CONT circuit breaker.

(10) Turn hydraulic test stand (S2) ON. Adjust hydraulic test stand (S2) to sufficient pressure to maintain six gallons per minute minimum flow rate. Energize the directional SCAS system solenoid valve. Flush system for five minutes. Reduce pressure and turn hydraulic test stand (S2) OFF. De-energize the directional SCAS system solenoid valve. Reconnect all System 1 hoses except those on the two cyclic actuators.

**NOTE**

**With all actuators bypassed, the lockout valve isolates the cyclic actuators (650 to 850 psi is required to open the lockout valve),**

(11) Turn hydraulic test stand (S2) ON, adjust outlet pressure to **800 TO 1000** psig and flush for a minimum of three minutes. Reduce pressure and shut hydraulic test stand (S2) off. Reconnect System 1 hoses on the cyclic actuators.

(12) Disconnect hydraulic test stand (S2) from System No. 1 and connect to System No. 2 through ground test fitting in module assembly.

(13) Turn hydraulic test stand (S2) ON. Adjust hydraulic test stand (S2) pressure to maintain a flow rate of six gallons per minute. Turn electrical auxiliary power unit ON. Energize the pitch and roll SCAS system solenoid valves armament pylon actuator solenoid valve. This can be accomplished by positioning switches and circuit breakers as shown in steps (14), (d) and (14), (e). Flush system for 5 minutes. Reduce pressure and turn hydraulic test stand (S2) OFF. De-energize pitch and roll SCAS system solenoid valve. Reconnect pitch, roll and cyclic actuators hoses.

(14) Fill and flush emergency hydraulic system as follows:

(a) Drain fluid from reservoir (2, figure 7-41), paragraph 7-152).

(b) Remove filler cap from the reservoir (figure 7-5) mounted on bulkhead at station 213.94 in the hydraulic compartment under right wing. Using hydraulic fluid dispenser (S1), fill reservoir with clean hydraulic fluid (C61 or C62) (paragraph 7-6).

(c) Connect electrical auxiliary power unit (S16) to helicopter and energize.

(d) Energize the following circuit breakers:

- SECU PWR                    TMS BLWR
- HYD CONTR                REF XFMR
- ARMT CONTR              INV
- WPN CONTR
- TMS PWR

(e) Position the following switches:

- Pilot BATT switch . . . . . RUN
- PLT MASTER ARM. . . . . STBY

- Gunner MODE SELECT
- Switch . . . . . ARMED MAN

ARMED AUTO  
LAUNCHER ACTIVATE SWITCH  
Located in ammo bay. . . . LH or RH  
This will open the hydraulic solenoid valve for the articulated pylons.

**To prevent pump damage (running dry), engage pilot or gunner EMER HYDR PUMP switch to BORESIGHT position with a momentary ON-OFF action until the pump is filled.**

(f) Position pilot or gunner EMER HYDR PUMP switch to BORESIGHT with a momentary ON-OFF action until pump is filled, then operate steadily for five minutes to flush the system.

(g) Continue filling reservoir during flushing run until all air is purged and reservoir is full.

(h) Position pilot and gunner EMER HYDR pump switches to OFF.

(i) Turn electrical auxiliary power unit (S16) OFF.

(j) Switches listed in step (d) to OFF.

(k) De-energize the circuit breakers listed in step (d).

(15) Provide a small container to catch oil when disconnecting hoses after a flushing operation. Remove dust caps from dual hydraulic cylinder ports. Reconnect hoses to cyclic and collective dual hydraulic cylinders and to wing pylon servo actuators.

(16) Replace filter elements previously removed. Torque filter bowls 100 TO 140 inch-pounds and secure with lockwire (C137).

(17) Using hydraulic fluid dispenser (S1), fill System No. 1 and No. 2 reservoir with clean hydraulic fluid (C61 or C62) until all air is purged and reservoirs are full (paragraph 7-6).

(18) Bleed hydraulic system in accordance with procedures outlined in paragraph 7-146.

(19) Disconnect hydraulic test stand (S2) and electrical auxiliary power unit (S12) from helicopter.

NOTE

Cyclic dual hydraulic cylinder lines may have residual pressure caused by lockout valve and accumulator assembly.

7-148. **E M** TROUBLESHOOTING - HYDRAULIC SYSTEM.

NOTE

The following list of conditions, tests or inspections and corrective actions is intended to aid in hydraulic system troubleshooting. This guide should be used with other sources of information, such as: (1) Hydraulic System Schematic Illustration FO2. (2) Electrical diagrams; and (3) Operational Ground Test and other detailed procedures in this section.

Ensure that all normal operational checks have been performed prior to using table 7-13. Any malfunctions not listed require assistance of next higher level of maintenance.

Table 7-13. **E M** Troubleshooting Hydraulic System

CONDITION

TEST OR INSPECTION

**CORRECTIVE ACTION**

1. Pilot #1 HYD PRESS, pilot #2 HYD PRESS, gunner #1 HYD PRESS or gunner #2 HYD PRESS caution panel worded segments reported being illuminated during normal operation.

STEP 1. Loss of fluid and pressure by leakage.

Locate and repair leaks; replace faulty lines, hoses, seals, or other parts. Service system as required (paragraph 7-6).

Table 7-13. **F M** Troubleshooting Hydraulic System (Cent)

---

CONDITION

TEST OR INSPECTION

**CORRECTIVE ACTION**

STEP 2. Total loss of fluid in system.

**Replace pump (paragraphs 7-168 and 7-172).**

STEP 3. Other malfunction in system.

**Perform operational check with hydraulic test stand (S2) (paragraph 7-146).**

STEP 4. If pilot #1 HYD PRESS, pilot #2 HYD PRESS, gunner #1 HYD PRESS or gunner #2 HYD PRESS caution panel worded segments do not illuminate and system operates normally with hydraulic test stand (S2), trouble maybe in pump circuitry or pump may be defective.

**Replace pump (paragraphs 7-168 and 7-172).**

STEP 5. Pump pressure line restricted or check valve reversed.

**Replace or correct installation of parts (paragraph 7-159).**

STEP 6. If system actuators operate normally on hydraulic test stand (S2), but caution panel worded segment is illuminated, warning circuit or pressure switches may be faulty.

**Replace pressure switch hydraulic modular unit (figure 7-4).**

STEP 7. Electric circuit malfunction.

**Check and repair electrical circuit (paragraphs 9-8 through 9-13 and paragraph 9-284).**

STEP 8. If caution panel worded segment is illuminated, and system actuators do not operate normally with hydraulic test stand (S2), trouble may be in hydraulic modular unit or in system beyond hydraulic modular unit.

STEP 9. Hydraulic modular unit solenoid valve staying at OFF position or faulty HYD TEST switch.

**Repair electrical circuit (paragraphs 9-8 through 9-13 and paragraph 9-317). Replace switches (paragraphs 9-20 and 9-22). Replace hydraulic modular unit (paragraphs 7-182 and 7-1 86).**

STEP 10. System relief valve staying open or relieving at too low pressure.

**Replace relief valve in hydraulic modular unit (figure 7-4).**

STEP 11. Internal leakage through a unit.

**Isolate and replace defective unit.**

Table 7-13. **E** **M** Troubleshooting Hydraulic System (Cent)

## CONDITION

## TEST OR INSPECTION

**CORRECTIVE ACTION**

2. (SCAS) actuator will not unlock from center position.

STEP 1. Faulty wiring, switches or connections.

**Refer to chapter 11 and TM 11-1520-236-20 or TM 11-1520-236-34, Troubleshooting Stability and Control Augmentation System (SCAS).**

STEP 2. Filter clogged.

**Replace in line hydraulic filter (paragraph 7-222).**

STEP 3. Restricted flow in pump suction line.

**Inspect reservoir and lines; replace faulty parts (paragraphs 7-155 and 7-163).**

3. Pilot #1 HYD PRESS and/or gunner #1 HYD PRESS caution panel worded segments do not illuminate when HYD TEST switch is positioned to SYS 2 or Pilot #2 HYD PRESS and/or gunner #2 HYD PRESS caution panel worded segments do not illuminate when HYD TEST switch is positioned to SYS 1.

STEP 1. Caution panel lamp or light indicating panel (caution panel) failed.

**Replace panel lamp (paragraph 9-282) or light indicating panel (caution panel) (paragraphs 9-281 and 9-283).**

STEP 2. Pressure switch in hydraulic modular unit or wiring faulty.

**Replace pressure switch (figure 7-4) or repair electrical circuit (paragraphs 9-8 through 9-13 and paragraph 9-284).**

STEP 3. System solenoid or electrical circuit faulty.

**Repair electrical circuit (paragraph 9-377) or replace hydraulic modular unit (paragraphs 7-182 and 7-186).**

STEP 4. Faulty HYD TEST switch.

**Replace switch.**

4. Filter element differential pressure indicators tripped.

STEP 1. Fluid temperature below 20 degrees F (-7 degrees C).

**Operate until fluid temperature is normal, then reset indicators by pushing buttons in. If not again tripped, no further action needed (figure 7-4) (paragraph 7-45).**

Table 7-13. **E** **M** Troubleshooting Hydraulic System (Cent)

CONDITION

TEST OR INSPECTION

**CORRECTIVE ACTION**

STEP 2. Indicators tripped by unusual vibration or hydraulic modular unit being struck.

**Check hydraulic modular unit for damage, reset indicators. If not again tripped, no further action needed (figure 7-4).**

STEP 3. Clogged filter elements.

**Inspect and replace filter elements (paragraphs 7-189 and 7-193). Reset indicators (paragraph 7-45).**

STEP 4. Defective indicator assembly.

**Replace hydraulic modular unit (paragraphs 7-182 and 7-186).**

5. Servo cylinders chatter when controls are moved. (Some chatter in tail rotor control cylinder is normal when using hydraulic test stand (S2).

STEP 1. Air in system.

**Cycle controls at least ten full strokes at normal operating pressure to work out air (paragraph 7-146).**

STEP 2. Loose mounting bearing (9, figure 7-12) on dual hydraulic servo cylinder,

**Replace dual hydraulic servo cylinder assembly (paragraphs 7-203 and 7-209).**

STEP 3. Any internal looseness in dual hydraulic servo cylinder assembly.

**Replace dual hydraulic servo cylinder assembly (paragraphs 7-203 and 7-209).**

6. Controls do not operate smoothly.

STEP 1. Servo valve on dual hydraulic servo cylinder is binding (requires more than 12 oz. force to operate valve.)

**Check to ensure all bolts at servo head linkage are free to rotate by finger pressure. Replace dual hydraulic servo cylinder assembly (paragraphs 7-203 and 7-209).**

STEP 2. Incorrect bolts inserted.

**Check the valve linkage bolts. Install correct bolts.**

7. Excessive feedback in operation of controls.

STEP 1. Air in servo cylinders.

**Cycle controls at least ten times to work out air (paragraph 7-146).**

Table 7-13. **E M** Troubleshooting Hydraulic System (Cent)

## CONDITION

## TEST OR INSPECTION

**CORRECTIVE ACTION**

STEP 2. Loose or worn bearing housing mounting studs.

**Tighten or replace mounting studs.**

8. Hydraulic power inadequate or lacking at TMS launchers (other indications normal).

STEP 1. Faulty circuit to armament couplings or System No. 2 pressure is marginally low.

**Check operation with hydraulic test stand (S2) (paragraph 7-146).**

STEP 2. No improvement when using hydraulic test stand (S2) for normal system pressure, or TMS solenoid valve inoperative.

**Replace solenoid valve (paragraphs 7-240 and 7-244) or repair electrical circuit (paragraphs 9-8 through 9-13 and paragraph 9-374).**

STEP 3. Restriction in test connectors (25, figure 7-4) or lines.

**Replace defective parts (paragraphs 7-161 and 7-165).**

STEP 4. Operation becomes normal on hydraulic test stand (S2). System No. 2 pump or lines defective.

**Replace pump (paragraphs 7-168 and 7-172) or faulty lines (paragraphs 7-161 and 7-165).**

9. System No. 2 reservoir overflows.

**NOTE**

**Within one hour after helicopter shut down approximately 1 cubic inch of hydraulic fluid from accumulator P/N 204-076-012-5 will be added to system 2. On start up approximately 1 cubic inch of hydraulic fluid will be removed from system 1 reservoir to fill accumulator P/N 204-076-012-5.**

STEP 1. Repeat cyclic inputs with hydraulic system test switch in System No. 1 position.

**Release hydraulic system test switch. Actuate cyclic stick, approximately ten full cycles, to remove air from actuators (paragraph 7-146). Replenish fluid in reservoir (paragraph 7-149).**

10. Either left or right TOW pylons inoperative or sluggish. (System No. 2 operation otherwise normal).

STEP 1. Electrical wiring faulty.

**Repair electrical circuit (paragraphs 9-8 through 9-13 and paragraph 9-374).**

STEP 2. Faulty electrical circuit to actuator.

**Repair electrical circuit (paragraphs 9-8 through 9-13 and paragraph 9-374).**

CONDITION

TEST OR INSPECTION

**CORRECTIVE ACTION**

STEP 3. TOW solenoid valve stuck closed.

**Replace solenoid valve (paragraphs 7-240 and 7-244).**

STEP 4. Check SECU and TOW system.

11. Only one TOW pylon inoperative or sluggish. (Other TOW pylon operates normally.)

STEP 1. Restricted hydraulic flow in circuit of affected armament wing pylon servo actuator.

**Inspect hoses and tubes; replace faulty parts (paragraph 7-159).**

STEP 2. Faulty electrical circuit to affected armament wing pylon servo actuator.

**Repair electrical circuit (paragraphs 9-8 through 9-13 and paragraph 9-374).**

STEP 3. Defective armament wing pylon servo actuator.

**Replace armament wing pylon servo actuator (paragraphs 7-254 and 7-268).**

STEP 4. Check SECU and TOW system.

12. Pylons do not remain in stowed position with TOW system OFF and hydraulic system operations.

STEP 1. Fault in electrical wiring.

**Repair electrical circuit (paragraphs 9-8 through 9-13 and paragraph 9-374).**

STEP 2. Faulty electrical circuit to pylon servo actuators.

**Repair electrical circuit (paragraphs 9-8 through 9-13 and paragraph 9-374).**

STEP 3. TOW solenoid valve stuck open.

**Replace solenoid valve (paragraphs 7-240 and 7-244).**

STEP 4. Check valve installed backwards or stuck open.

**Reverse or replace check valve (figure FO-1).**

STEP 5. Check SECU.



Table 7-13. **E M** Troubleshooting Hydraulic System (Cent)

## CONDITION

## TEST OR INSPECTION

**CORRECTIVE ACTION**

13. With hydraulic test stand (S2) and electrical power unit (S12) connected to helicopter and operating, and with pilot and/or gunner EMER HYDR PUMP switch in BORESIGHT position, pilot and/or gunner green EMER HYDR PUMP caution panel worded segments do not illuminate.

STEP 1. If collective controls are powered, check for a faulty panel lamp or light indicating panel (caution panel).

**Replace panel lamp (paragraph 9-282) or light indicating panel (caution panel) (paragraphs 9-281 and 9-283).**

STEP 2. If collective controls are powered, check for faulty electrical wiring.

**Repair wiring (paragraphs 9-8 through 9-13 and paragraph 9-284).**

STEP 3. If collective controls are powered, check for faulty pressure switch.

**Replace pressure switch in hydraulic modular unit (figure 7-4).**

STEP 4. If collective controls are unpowered and emergency electric motor driven pump package failed, check for faulty wiring or switch.

**Repair wiring (paragraph 9-8 through 9-13) or replace switch (paragraphs 9-20 through 9-22) or replace emergency electric motor driven pump package (paragraphs 7-175 and 7-179).**

14. With electrical power unit (S12) connected to helicopter and operating, and with pilot and/or gunner EMER HYDR PUMP switch in BORESIGHT or EMER position, and pilot and gunner green EMER HYDR PUMP caution panel worded segments illuminated, System No. 2 is non-operative and collective controls are unpowered.

STEP 1. Faulty electrical wiring.

**Repair wiring. Refer to paragraphs 9-8 through 9-13 and paragraphs 9-374.**

STEP 2. Pressure or return solenoid valve failed.

**Replace pressure or return solenoid valve (paragraphs 7-240 and 7-244).**

15. With electrical auxiliary power unit (S12) connected to helicopter and turned ON, pilot and/or gunner EMER HYDR PUMP switch in EMER position, System No. 2 non-operative armament wing pylons are powered when switches are engaged.

STEP 1. Faulty electrical wiring to armament wing pylon solenoid valve.

**Repair wiring. Refer to paragraphs 9-8 through 9-13 and paragraph 9-374.**

Table 7-13. **E M** Troubleshooting Hydraulic System (Cont)

CONDITION

TEST OR INSPECTION

**CORRECTIVE ACTION**

16. With electrical auxiliary power unit (S12) connected to helicopter and turned ON, pilot and/or gunner EMER HYDR PUMP switch in BORESIGHT position, System No. 2 non-operative, wing pylons are not powered when switches are engaged.

STEP 1. Faulty electrical wiring to armament wing pylon solenoid valve.

**Repair wiring (paragraphs 9-8 through 9-13 and paragraph 9-374), or replace pylon solenoid valve (paragraphs 7-240 and 7-244), or replace armament wing pylon servo actuator (paragraphs 7-254 and 7-268).**

17. **M** Emergency electric hydraulic pump cycles on and off at very short intervals.

STEP 1. One-way check valve (45, figure 7-40) inoperative due to internal leakage.

**Replace one-way check valve (45, figure 7-40).**

**7-149. E M SERVICING – HYDRAULIC SYSTEM.**

Service hydraulic system in same manner outlined for **P** coded helicopters (paragraph 7-6).

**7-150. E M HYDRAULIC RESERVOIR.**

**7-151. E M DESCRIPTION – HYDRAULIC RESERVOIR.**

The hydraulic reservoirs on **E** and **M** coded helicopters are similar to the reservoirs on ~ coded helicopters (paragraph 7-8).

**7-152. E M REMOVAL – HYDRAULIC RESERVOIR.**

Remove hydraulic reservoir by same procedure outlined for **P** coded helicopters (paragraph 7-9).

**7-153. E M DISASSEMBLY – HYDRAULIC RESERVOIR.**

Disassemble hydraulic reservoir by same procedure outlined for **P** coded helicopters (paragraph 7-10).

**7-154. q M CLEANING – HYDRAULIC RESERVOIR.**

Clean hydraulic reservoir by same procedure outlined for **P** coded helicopters (paragraph 7-11).

**7-155. E M INSPECTION – HYDRAULIC RESERVOIR.**

Inspect hydraulic reservoir by same procedure outlined for **P** coded helicopters (paragraph 7-12).

**7-156. E M REPAIR OR REPLACEMENT – HYDRAULIC RESERVOIR.**

Repair hydraulic reservoir by same procedure outlined for **P** coded helicopters (paragraph 7-13).

**7-157. E M ASSEMBLY – HYDRAULIC RESERVOIR.**

Assemble hydraulic reservoir by same procedure outlined for **P** coded helicopters (paragraph 7-14).

**7-158. E M INSTALLATION – HYDRAULIC RESERVOIR.**

- a. Install hydraulic reservoir by same procedure outlined for **P** coded helicopters (paragraph 7-15).
- b. Perform functional test of hydraulic system (paragraph 7-143).

**7-159. E M HOSES, TUBES, AND FITTINGS.****7-160. E M DESCRIPTION – HOSES, TUBING AND FITTINGS.**

Throughout No. 1, No. 2 and emergency hydraulic systems are hoses, tubing, and fittings that interconnect reservoirs, check valves, relief valves, solenoid valves, pumps, etc. and are attached to fuselage structure with clamps, spacers, screws and nuts.

**7-161. E M REMOVAL – HOSES, TUBING AND FITTINGS.**

Remove hoses, tubing and fittings as required to perform maintenance functions (figure 7-40).

**7-162. E M CLEANING – HOSES, TUBING AND FITTINGS.**

**Cleaning solvent is flammable and toxic. Provide adequate ventilation. Avoid prolonged breathing of solvent vapors and contact with skin or eyes. Eye protection is required when using compressed air.**

- a. Wash hoses, tubing, and fittings with solvent (C112) and dry with clean filtered compressed air.
- b. Clean hoses, tubing and fittings with clean filtered compressed air prior to installation.

**7-163. E M INSPECTION – HOSES, TUBING, AND FITTINGS.**

- a. Inspect tubing for nicks, cuts, cracks, and deformed condition (TM 55-1500-204-25/1). Minor

nicks, scratches, and dents on fittings are acceptable provided they are sanded smooth with 600 grit sandpaper (C102), treated with chemical film material (C31) and touched up with primer (C88 or C91).

- b. Inspect threaded parts for corrosion and mechanical damage. Damaged threads are not acceptable.

- c. Inspect hoses for fraying, cuts, and deterioration. Damage more severe than superficial is not acceptable.

**7-164. E M REPAIR OR REPLACEMENT – HOSES, TUBING, AND FITTINGS.**

- a. Replace parts that fail to meet inspection requirements of paragraph 7-163.
- b. Refer to appendix D and to TM 55-1500-204-25/1 for instructions to fabricate tubing and hoses.

**7-165. E M INSTALLATION – HOSES, TUBING, AND FITTINGS (figures 7-40 and 7-41).**

- a. Ensure that hoses and tubes are clear of obstructions prior to installation.
- b. Coat seals, packings and threads with clean hydraulic fluid (C61 or C62).
- c. Position tubing or hose assembly in helicopter. See figures 7-40 and 7-41. Align the tubing or hose assembly and install end connectors. Ensure that hoses do not twist during tightening end connectors. Torque end connectors to value shown in table 7-4.
- d. Inspect hoses for free movement and for chafing on adjacent components when cylinders are operating through full throw.
- e. Spiral wrap all areas on hoses where chafing may occur. Use teflon tape (C178).
- f. Inspect for hydraulic fluid leaks while the system is under pressure.

Perform functional check of the hydraulic system (paragraph 7-146).

**7-166. E M HYDRAULIC PUMPS (TRANSMISSION DRIVEN).**

**7-167. E M DESCRIPTION – HYDRAULIC PUMPS (TRANSMISSION DRIVEN)**

Dual hydraulic pumps are mounted on a drive quill located on the transmission lower case, and is accessible by opening right transmission cowling door (11, figure 2-3). System No. 1 pump is on aft pad of drivequill, and System No. 2 pump is on forward pad. See figure 7-40.

**7-168. E M REMOVAL – HYDRAULIC PUMPS (TRANSMISSION DRIVEN).**

Either pump can be removed in the same manner.

a. Open right transmission cowling (11, figure 2-3). Place a suitable container under pump to catch spilled fluid.

b. Loosen hose nuts on SUCTION port fitting on outboard end of pump and pressure port fitting at forward side. Allow fluid to drain into container. Disconnect both hoses. Cap hoses and fittings.

c. Disconnect hose from CASE DRAIN port fitting at top inboard on pump. Cap hose and fitting.

d. Disconnect hose from SEAL DRAIN port fitting at bottom inboard on pump. Cap hose and fitting.

e. Remove washers and nuts from four mounting studs at flange of pump. Pull pump and gasket from drive pad. Cover drive pad to protect from dirt.

f. If pump is being replaced, remove fittings from ports for use on replacement pump. Cover open pump ports. Protect driveshaft from dirt and damage.

**7-169. E M CLEANING – HYDRAULIC PUMPS (TRANSMISSION DRIVEN).**



**Cleaning solvent is flammable and toxic. Provide adequate ventilation. Avoid prolonged breathing of solvent vapors and contact with skin or eyes. Eye protection is required when using compressed air.**

a. Clean external surface of pump with solvent (C112). A soft bristle brush maybe required to loosen caked dirt/grease deposit. Do not submerge pump in solvent.

b. Dry pump using clean filtered compressed air.

**7-170. E M INSPECTION – HYDRAULIC PUMPS (TRANSMISSION DRIVEN).**

a. Inspect pump for leaks (table 7-1).

b. Inspect pump for cracks. No cracks are acceptable.

c. Inspect pump for security.

d. Inspect drive pad on transmission for leaks.

e. Inspect attaching hose connections for leaks.

f. Inspect pump for corrosion. Superficial corrosion is acceptable on external surfaces if polished out and treated for corrosion protection. Corrosion on threads or internal parts is not acceptable.

g. Check pressure in both hydraulic systems No. 1 and No. 2. Pressure should be 1475 to 1525 psi.

**7-171. E M REPAIR OR REPLACEMENT – HYDRAULIC PUMPS (TRANSMISSION DRIVEN).**

a. Replace pumps that fail to meet inspection requirements of paragraph 7-170.

b. Polish out superficial corrosion on external surface. Polish to original surface finish with 600 grit sandpaper (C102).

c. Treat with chemical film (C31).

d. Touch up with primer (C88 or C91).

**7-172. E M INSTALLATION –  
HYDRAULIC PUMP (TRANSMISSION  
DRIVEN).**

- a. Install pump (6, figure 7-40) or pump (31) in the same manner.



Install P/N 212-076-364-3 or vendor P/N 2514-6 check valve in pump case drain port.



b. Before installing fitting on new pump, remove case drain plug and drain preservative fluid from pump. Fill pump with clean hydraulic fluid (C61 or C62) and install check valve.

c. If the same pump is not being reinstalled, install fittings from old pump at suction port on outboard end, pressure port on forward side, case drain port at top inboard end, and seal drain port at bottom inboard end. Use new packings.

d. Apply a thin film of antisieze compound (C21) to pump splines and to mating splines in transmission.

e. Position new gasket and pump (6 or 31) on transmission drive pad. Engage splines. Install washers and nuts on studs.

f. Connect hoses to suction, pressure, case drain and seal drain port fittings. Seal area around hydraulic pump and quill assembly mating flanges (Paragraph 6-54.f.).

g. Refill reservoir (paragraph 7-149). Bleed system (paragraph 7-146).

**7-173. E M HYDRAULIC PUMP (EMERGENCY — ELECTRIC MOTOR DRIVEN).**

**7-174. E M DESCRIPTION — HYDRAULIC PUMP (EMERGENCY — ELECTRIC MOTOR DRIVEN).**

The emergency hydraulic system is powered by an electric motor driven, pressure compensated, variable delivery, hydraulic pump (9, figure 7-41 ). The leading particulars for both the hydraulic pump and the electric motor are as follows:

Pump:

Rated discharge pressure	
Full Flow	1100 psig minimum
Zero flow	1250 psig maximum
Rated inlet pressure	10 psig
Rated full flow	1.0 gpm minimum

Electric motor:

Rated voltage	28 volt dc nominal
Rated current	40 amperes maximum at full flow 18 amperes maximum zero flow
Speed	5400 rpm maximum at zero flow

**7-175. M M REMOVAL — HYDRAULIC PUMP (EMERGENCY — ELECTRIC MOTOR DRIVEN).**

a. Gain access to emergency hydraulic pump by removing right access panel (17, figure 2-3).

b. Remove lockwire and disconnect electrical plug from pump assembly (4, figure 7-7).

c. Remove four bolts (5) and four washers (6) attaching pump assembly (4) to shelf.

d. Provide a suitable one gallon container. Place container under pump assembly directly below SUC-TION hose connection. Break torque on connector of tube (10) and allow fluid to drain from system slowly. It may be necessary to remove filler caps from all three reservoirs to allow better drainage. Remove tube (10) from fitting (11) and install protective dust cap to tube.

e. Remove tube (13) from fitting (14). Install protective dust cover to tube connector.

f. Remove tube (3) from fitting (2). Install protective dust cover to tube connector.

g. Remove hose assembly (9) from fitting (8) and remove pump assembly (4) from helicopter. Install protective dust cover to hose connector. Remove fitting (8) from pump assembly and card packing (7).

h. Drain remainder of fluid from pump assembly.

i. Remove fitting (11) and discard packing (12) from pump assembly (4).

j. Remove fitting (2) from pump assembly (4). Remove packing (1) from fitting (2). Discard packing.

k. Remove fitting (14) from pump assembly (4). Remove packing (15) from fitting (14). Discard packing.

l. Clean pump assembly (paragraph 7-176).

m. Fill pump assembly (4) with hydraulic fluid preservative (C61 or C62) and plug or cap all open port holes and electrical connector.

n. Wrap pump assembly in barrier material (C22) and secure with tape (C127). Send pump to next higher level of maintenance.

**7-176. E M CLEANING – HYDRAULIC PUMP (EMERGENCY – ELECTRIC MOTOR DRIVEN).**

**WARNING**

Cleaning solvent is flammable and toxic. Provide adequate ventilation. Avoid prolonged breathing of solvent vapors and contact with skin or eyes. Eye protection is required when using compressed air.

**CAUTION**

Do not submerge pump assembly (4, figure 7-4) in dry cleaning solvent as it will damage internal components.

a. Wash pump assembly with a clean rag saturated with solvent (C112). A soft bristle brush may be required to remove stubborn deposits of caked dirt and oil.

b. Dry pump assembly with clean filtered compressed air.

**7-177. E M INSPECTION – HYDRAULIC PUMP (EMERGENCY – ELECTRIC MOTOR DRIVEN).**

**NOTE**

**The following inspection procedures are applicable to external surfaces and threaded bosses only. No internal inspections of the pump are authorized at this level of maintenance.**

a. Inspect hydraulic pump assembly (4, figure 7-7) for leaks (table 7-1).

b. Inspect pump/ motor package for corrosion and mechanical damage. Damage within limits noted below is acceptable if polished out.

(1) Corrosion damage – maximum depth:

Hydraulic pump — 0.015 inch (0.030 inch after cleanup).

Electric motor — 0,030 inch (0,060 inch after cleanup).

(2) Nicks and scratched — maximum depth:

Hydraulic pump — 0,030 inch (0.030 inch after cleanup).

Electric motor — 0.060 inch (0.060 inch after cleanup).

(3) Dent or deformation – maximum depth:

Hydraulic pump — 0.010 inch (0.030 inch after cleanup).

Electric motor — 0.050 inch (0.060 inch after cleanup).

(4) Cracks: No cracks are acceptable.

c. Inspect electrical connection to pump assembly (4) for corrosion, damaged threads, and bent or broken pins.

d. Inspect threaded ports in pump for damage. Maximum acceptable thread damage is one-third of thread depth 0.250 inch in length, and one damage per port.

e. Pumps that seem excessively noisy in comparison to other AH-IS emergency pumps, should be removed and sent to the appropriate depot for analysis and resulting required maintenance.

**7-178. E M REPAIR OR REPLACEMENT – HYDRAULIC PUMP (EMERGENCY – ELECTRIC MOTOR DRIVEN).**

a. Replace pumps which fail to meet inspection requirement of paragraph 7-177.

b. Polish out mechanical and corrosion damage that is within repairable limits noted in paragraph 7-177. Use 600 grit sandpaper (C102) and polish to original finish.

c. Touch up with primer (C88 or C91).

**7-179. E M INSTALLATION – HYDRAULIC PUMP (EMERGENCY – ELECTRIC MOTOR DRIVEN).**

a. Remove case drain plug from top of Pump assembly and drain preservative fluid. Using



hydraulic fluid dispenser (S1), fill pump with clean hydraulic fluid (C61 or C62) and install case drain plug. Secure case drain plug with lockwire (C137).

b. Install packing (1, figure 7-7) on fitting (2) and install fitting into CASE DRAIN port, located top center of pump.

c. Install packing (7) on fitting (8) and install fitting into SEAL DRAIN port, located on lower end of pump.

d. Install packing (12) on fitting (11) and install fitting into SUCTION port, located on forward face of pump (outboard).

e. Install packing (15) on fitting (14) and install fitting into PRESSURE port, located on forward face of pump (inboard).

f. Remove protective dust covers from connectors of tubes (3, 10, and 13) and hose assembly (9). Check tube and hose connectors for thread damage.

g. Position pump assembly (4) on shelf and under bonding strap. Install four bolts (5), and four washers (6).



Ensure that tubes and the hose are free of obstructions prior to installation.

h. Install tubes (3, 10 and 13) on fittings (2, 11 and 14). Torque per table 7-4.

i. Install hose (9) on fitting (8). Ensure that hose does not kink during installation procedure. Torque per figure 7-4.

j. Connect electrical plug to pump assembly and lockwire.

k. Perform functional check of hydraulic system (paragraph 7-146).

**7-180. E M HYDRAULIC MODULAR UNIT.**

**7-181. E M DESCRIPTION - HYDRAULIC MODULAR UNIT.**

Two hydraulic modular units are located in a compartment at top of the fuselage between pilot canopy and the transmission pylon, on front of bulkhead at Station 186.25. See figure 7-40. Hinged

doors (8, figure 2-3) at each side give access to the compartment. Each hydraulic modular unit consists of a housing equipped with the system solenoid valve, relief valve, pressure switch for caution panel light, pressure and return filters, filter indicators (popout button), marked ports for system connections. Two quick-disconnect couplings are located on right modular unit for connection of hydraulic test stand (S2). One coupling is also used in normal operation for the return hose to the reservoir. System No. 1 hydraulic modular unit is at left, and System No. 2 hydraulic modular unit at right on bulkhead.

**7-182. E M REMOVAL - HYDRAULIC MODULAR UNIT.**

a. Open left and right door (8, figure 2-3).

b. Place a container under module (3, figure 7-40) or the opposite model that is being removed.

c. Disconnect electrical connectors from solenoid and pressure switch at top of module.

d. Disconnect return line hose from quick-disconnect coupling on front of module, and four tubes from fittings at side ports. Cap fittings and open ends of tubes.

e. Remove three bolts, with washers and nuts, to detach module from bulkhead. Remove module from compartment.

f. If module is not to be reinstalled, remove fittings for installation on replacement module.

**7-183. E M CLEANING - HYDRAULIC MODULAR UNIT.**



Cleaning solvent is flammable and toxic. Provide adequate ventilation. Avoid prolonged breathing of solvent vapors and contact with skin or eyes. Eye protection is required when using compressed air.

a. Clean electrical components with dry, filtered compressed air.



Do not submerge module unit in dry cleaning solvent.

b. Clean external surfaces of module with solvent (C112).

**7-184. E M INSPECTION - HYDRAULIC MODULAR UNIT.**

a. Inspect modular units for nicks, dents, scratches and cracks. Superficial mechanical damage is acceptable without repair. No cracks allowed.

b. Inspect thread, in threaded bosses for damage. Thread damage that could affect function is not acceptable.

c. Inspect modular units for leaks and malfunction during operational checks (paragraph 7-146).

**7-185. E M REPAIR OR REPLACEMENT - HYDRAULIC MODULAR UNIT. (AVIM)**

a. Replace modular units that fail to meet inspection requirements of paragraph 7-184.

b. Touch up external finish with primer (C88 or C91).

**7-186 E M INSTALLATION - HYDRAULIC MODULAR UNIT.**

a. Install pressure switch (1, figure 7-40), bypass solenoid valve (2), filters and fittings in module housing if not previously accomplished. Use new packings and gaskets. Torque pressure switch jam nut 40 to 50 inch-pounds. Safety to module housing using lockwire (C137).

b. Position hydraulic modular unit (3) on bulkhead with pressure ports at outboard side. Align mounting holes. Insert three bolts through module housing and bulkhead, and install washers and nuts at back of bulkhead.

c. Connect hydraulic system tubes to fittings at marked ports. Connect hose from reservoir RETURN port to quick-disconnect coupling.

d. Connect electrical connectors to bypass solenoid valve (2) and to pressure switch (1).

e. Install opposite hydraulic modular unit in same manner outlined in steps a through d.

f. Perform operational check of hydraulic system (paragraph 7-146).

**7-187. E M FILTER ELEMENTS.**

**7-188. E M DESCRIPTION - FILTER ELEMENTS.**

The filter elements on E and M coded helicopters are similar to the filter elements on P coded helicopters (paragraph 7-45).

**7-189. E M REMOVAL - FILTER ELEMENTS.**

Remove filter elements using same procedures outlined for P coded helicopters (paragraph 7-46).

**7-190. E M CLEANING - FILTER ELEMENTS.**

Do not clean paper-type filter elements.

**7-191. E M INSPECTION - FILTER ELEMENTS.**

Inspect filter elements using same procedures outlined for P coded helicopters (paragraph 7-46, step e).

**7-192. E M REPAIR OR REPLACEMENT - FILTER ELEMENTS.**

Install new paper-type filter elements P/N 205-076-034-3.

**7-193. E M INSTALLATION - FILTER ELEMENTS.**

Install filter elements using same procedures outlined for P coded helicopters (paragraph 7-50).

**7-194. E M ACCUMULATOR AND LOCKOUT VALVE.**

**7-195. E M DESCRIPTION - ACCUMULATOR AND LOCKOUT VALVE.**

The accumulator and lockout valves on E and M coded helicopters are similar to the accumulator and lockout valves used on P coded helicopters (paragraph 7-52).

**7-196. E M REMOVAL - ACCUMULATOR AND LOCKOUT VALVE.**

Remove the accumulator and lockout valve using the same procedures outlined for **P** coded helicopters (paragraph 7-53).

**7-197. E M CLEANING - ACCUMULATOR AND LOCKOUT VALVE.**

Clean the accumulator and lockout valve using the same procedures outlined for **P** coded helicopters (paragraph 7-54).

**7-198. E M INSPECTION - ACCUMULATOR AND LOCKOUT VALVE.**

Inspect the accumulator and lockout valve using the same procedures outlined for **P** coded helicopters (paragraph 7-55).

**7-199. E M REPAIR OR REPLACEMENT - ACCUMULATOR AND LOCKOUT VALVE.**

Repair or replace the accumulator and lockout valve using same procedures outlined for **P** coded helicopters (paragraph 7-56).

**7-200. E M INSTALLATION - ACCUMULATOR AND LOCKOUT VALVE.**

Install the accumulator and lockout valve using the same procedures outlined for **P** coded helicopters (paragraph 7-57).

**7-201. E M DUAL HYDRAULIC CYLINDERS.****7-202. E M DESCRIPTION - DUAL HYDRAULIC CYLINDERS.**

The dual hydraulic cylinders on **E** and **M** coded helicopters are similar to the dual hydraulic cylinders used on **P** coded helicopters (paragraph 7-59).

**7-203. E M REMOVAL - DUAL HYDRAULIC CYLINDERS.**

Remove dual hydraulic cylinders using same procedures outlined for **P** coded helicopters (paragraph 7-60).

**7-204. E M DISASSEMBLY - DUAL HYDRAULIC CYLINDERS (AVIM).**

Disassemble dual hydraulic cylinders using same procedures outlined for **P** coded helicopters (paragraph 7-58).

**7-205. E M CLEANING - DUAL HYDRAULIC CYLINDERS.**

Clean dual hydraulic cylinders using same procedures outlined for **P** coded helicopters (paragraph 7-62).

**7-206. E M INSPECTION - DUAL HYDRAULIC CYLINDERS.**

Inspect dual hydraulic cylinders using procedures outlined for **P** coded helicopters (paragraph 7-63).

**7-207. E M REPAIR OR REPLACEMENT - DUAL HYDRAULIC CYLINDERS.**

Repair or replace dual hydraulic cylinders using same procedures outlined for **P** coded helicopters (paragraph 7-64).

**7-208. E M ASSEMBLY - DUAL HYDRAULIC CYLINDERS (AVIM).**

Assemble dual hydraulic cylinders using same procedures outlined for **P** coded helicopters (paragraph 7-65).

**7-209. E M INSTALLATION - DUAL HYDRAULIC CYLINDERS.**

Install dual hydraulic cylinders using same procedures outlined for **P** coded helicopters (paragraph 7-66).

**7-210. E M INTERSYSTEM LEAKAGE - DUAL HYDRAULIC CYLINDERS.**

Dual hydraulic cylinders on **E** and **M** coded helicopters are similar to dual hydraulic cylinders on **P** coded helicopters (paragraph 7-67).

**7-211. E M SERVO VALVE REPLACEMENT - DUAL HYDRAULIC CYLINDERS (AVIM).**

Replace dual hydraulic cylinder servo valves using same procedures outlined for **P** coded helicopters (paragraph 9-68).

**7-212. E M REMOVAL - SERVO VALVE - DUAL HYDRAULIC CYLINDERS.**

Remove dual hydraulic cylinder servo valves using same procedures outlined for **P** coded helicopters (paragraph 7-69).

**7-213. E M INSTALLATION - SERVO VALVE - DUAL HYDRAULIC CYLINDERS.**

Install dual hydraulic cylinder servo valves using same procedures outlined for **P** coded helicopters (paragraph 7-70).

**7-214. E M (SCAS) SERVO ACTUATORS.**

**7-215. E M DESCRIPTION - (SCAS) SERVO ACTUATORS.**

The (SCAS) servo actuators on **E** and **M** coded helicopters are similar to the (SCAS) servo actuators on **P** coded helicopters (paragraph 7-72).

**7-216. E M REMOVAL - (SCAS) SERVO ACTUATORS,**

Remove (SCAS) servo actuators using same procedures outlined for **P** coded helicopters (paragraph 7-73).

**7-217. E M CLEANING - (SCAS) SERVO ACTUATORS.**

Clean (SCAS) servo actuators using same procedures outlined for **P** coded helicopters (paragraph 7-74).

**7-218. E M INSPECTION - (SCAS) SERVO ACTUATORS.**

Inspect (SCAS) servo actuators using same procedures outlined for **P** coded helicopters (paragraph 7-75).

**7-219. E M REPAIR OR REPLACEMENT - (SCAS) SERVO ACTUATORS.**

Repair or replace (SCAS) servo actuators using same procedures outlined for **P** coded helicopters (paragraph 7-76).

**7-220. E M INSTALLATION - (SCAS) SERVO ACTUATORS.**

Install (SCAS) servo actuators using same procedures outlined for **P** coded helicopters (paragraph 7-77).

**7-221. E M (SCAS) FILTER REPLACEMENT.**

**7-222. E M DESCRIPTION - (SCAS) FILTER REPLACEMENT.**

The (SCAS) filters on **E** and **M** coded helicopters are similar to (SCAS) filters on **P** coded helicopters (SCAS) filter replacement is similar (paragraph 7-79).

**7-223. E M CYLINDER AND SUPPORT ASSEMBLY - TAIL ROTOR CONTROL.**

**7-224. E M DESCRIPTION CYLINDER AND SUPPORT ASSEMBLY - TAIL ROTOR CONTROL.**

Tail rotor control cylinder and support assemblies on **E** and **M** coded helicopters are similar to tail rotor cylinder and support assemblies on **P** coded helicopters (paragraph 7-81).

**7-225. E M REMOVAL - CYLINDER AND SUPPORT ASSEMBLY - TAIL ROTOR CONTROL.**

Remove tail rotor control cylinder and support assembly by same procedures outlined for **P** coded helicopters (paragraph 7-82).

**7-226. E M DISASSEMBLY - CYLINDER AND SUPPORT ASSEMBLY - TAIL ROTOR CONTROL.**

Disassemble tail rotor control cylinder and support assembly using same procedures outlined for **P** coded helicopters (paragraph 7-83).

**7-227. E M CLEANING - CYLINDER AND SUPPORT ASSEMBLY - TAIL ROTOR CONTROL.**

Clean tail rotor control cylinder and support assembly using same procedures outlined for **P** coded helicopters (paragraph 7-84).

**7-228. E M INSPECTION - CYLINDER AND SUPPORT ASSEMBLY - TAIL ROTOR CONTROL.**

Inspect tail rotor control cylinder and support assembly using same procedures outlined for **P** coded helicopters (paragraph 7-85).

**7-229. E M REPAIR OR REPLACEMENT - CYLINDER AND SUPPORT ASSEMBLY - TAIL ROTOR CONTROL.**

Repair or replace tail rotor control cylinder and support assembly using same procedures outlined for **P** coded helicopters (paragraph 7-86).

**7-230. E M ASSEMBLY - CYLINDER AND SUPPORT ASSEMBLY - TAIL ROTOR CONTROL.**

Assemble tail rotor control cylinder and support assembly using same procedures outlined for **P** coded helicopters (paragraph 7-87).

**7-231. E M INSTALLATION - CYLINDER AND SUPPORT ASSEMBLY - TAIL ROTOR CONTROL.**

Install tail rotor control cylinder and support assembly using same procedures outlined for **P** coded helicopters (paragraph 7-88).

**7-232. E M SOLENOID VALVES.****7-233. E M SOLENOID VALVE P/N 88604-1 (2 AND 28, FIGURE 7-40).****7-234. E M DESCRIPTION SOLENOID VALVE P/N 88604-1 (2 AND 28, FIGURE 7-40).**

Solenoid valves (2 and 28) are located in the filter modules. The solenoid valves are controlled by the HYD TEST switch in the pilot engine control panel.

**7-235. E M CLEANING - SOLENOID VALVE P/N 88604-1.**

a. Clean solenoid valves (2 and 28, figure 7-40) while the valves are installed in the filter modules (paragraph 7-183).

**WARNING**

Cleaning solvent is flammable and toxic. Provide adequate ventilation. Avoid prolonged breathing of solvent vapors and contact with skin or eyes.

b. Clean the solenoid valves with a clean cloth moistened with solvent (C112). Use a soft bristle brush to remove stubborn deposits of dirt or oil.

**7-236. E M INSPECTION INSPECTION - SOLENOID VALVE P/N 88604-1.**

a. Inspect solenoid valves (2 and 28, figure 7-40) electrical connectors for bent or broken pins and damaged threads.

b. Inspect external surfaces of solenoid valves for nicks, dents and cracks. No cracks are acceptable.

c. Inspect area around solenoid valves for hydraulic fluid leaks.

**7-237. E M REPAIR OR REPLACEMENT - SOLENOID VALVES P/N 88604-1 (AVIM).**

a. Replace solenoid valve (2, figure 7-40) and hydraulic modular unit (3) as an assembly if solenoid valve (2) fails to meet inspection requirements of paragraph 7-250. Refer to paragraphs 7-39 and 7-43 for removal and installation instructions.

b. Replace solenoid valve (28) in the same manner outlined in the preceding step.

**7-238. E M SOLENOID VALVES**  
**P/N 204-076-504-3, FSCM 94641 P/N**  
**1-U-1025-63 OR FSCM 16780 P/N**  
**130027-5 (7, 8 AND 41, FIGURE 7-40).**

Three, three-way, two position solenoid valves (7, 8 and 41) are included in the hydraulic system to permit use of the electric, emergency hydraulic pump in the event of failure of system No. 1 and system No. 2 pumps. The solenoid valves are also used to permit use of the electric, emergency pump during boresighting procedures. The solenoid valves are controlled by the pilot and/or gunner EMER HYDR PUMP/BORESIGHT switch and the pilot MASTER ARM switch. See FO-2 (foldout 2) for view of hydraulic system schematic. See table 7-14 for leading particulars for solenoid valve (P/N 204-076-504-3 FSCM 94641 P/N 1-U-1025-63.

**7-239. E M DESCRIPTION -**  
**SOLENOID VALVES P/N 204-076-504-3,**  
**FSCM 94641 P/N 1-U-1025-63 OR FSCM**  
**16780 P/N 130027-5 (7, 8 AND 41, FIGURE**  
**7-40).**

**Table 7-14. Leading Particulars for Solenoid Valve P/N 204-076-504-3 FSCM 94641 1-U-1025-63**

Operating Medium . . . . . Hydraulic fluid: Military  
 Specification MIL-H-5605 (C62)  
 or  
 Military Specification  
 MIL-L-83282 (C61)

Pressures:

Operating . . . . . 1500 psig  
 Proof . . . . . 3000 psig  
 Burst . . . . . 4500 psig

Leakage:

External . . . . . none  
 Internal (at 3000 psig) . . . . . 3 cc per minute maximum with  
 solenoid energized; 1 cc per  
 minute maximum with solenoid  
 de-energized

PE Drop

(Port 2 to 1, or 2 to 3):

At +21 degrees C (+70 degrees F) . . . . . 75 psig (maximum) at 3 gpm flow  
 At -54 degrees (-65 degrees F) . . . . . 200 psig (maximum at gpm flow)

Solenoid Characteristics:

Voltage Range . . . . . 18 to 30 volts dc  
 Current Drain at 28 volts dc  
 and +21 degrees C (+70 degrees F) . . . . . 1.2 amperes (maximum)

**Table 7-14. Leading Particulars for Solenoid Valve P/N 204-076-504-3  
FSCM 94641 1-U-1025-63 (Cont)**

Ambient Temperature  
 Range: ..... -54 degrees C (-65 degrees F) to  
 +71 degrees C (+160 degrees F)

Weight ..... 1.25 pounds

**Premaintenance Requirements for Solenoid Valves  
 P/N 204-076-504-3, FSCM 94641 P/N  
 1-U-1025-63 or FSCM 16780 P/N 130027-5**

Conditions	Requirements
Model	AH-1S
Part No. or Serial No.	204-076-504-3
Special Tools	None
Test Equipment	Hydraulic test stand (S2) Pressure drop test setup (figure 7-25) functional test setup (figure 7-26) 30 Vdc power supply
Support Equipment	
Minimum Personnel Required	Two
Consumable Materials	(C22) (C30) (C31) (C36) (C37) (C61) (C62) (C63) (C88) (C91) (C112) (C137)
Special Environmental Conditions	None

(2) Disconnect electrical connector from solenoid valve (6, figure 7-42).

(3) Provide a suitable container to catch fluid when disconnecting tubes (1, 10 and 14) from solenoid valve (6).

(4) Remove tube (14) from solenoid valve (6).

(5) Disconnect tubes (1 and 10) from solenoid valve (6).

(6) Remove two bolts (31) and two washers (32) attaching solenoid valve (6) to bulkhead and remove solenoid valve.

(7) Drain hydraulic fluid from solenoid valve (6) and remove fitting (13). Remove packing (12) from fitting (13).

(8) Loosen nut (9) and remove elbow (11) from solenoid valve (6). Remove packing (7), ring (backup) (8), and nut (9) from elbow (11).

(9) Loosen nut (3) and remove elbow (2) from bypass solenoid valve (6). Remove packing (5), ring (backup) (4), and nut (3) from elbow (2).

(10) Install protective dust covers to open ports and electrical connector of solenoid valve (6) to prevent entry of foreign particles.

b. Remove solenoid valve (23, figure 7-42) as follows:

(1) Remove right fuselage access panel (17, figure 2-3).

(2) Disconnect electrical connector from solenoid valve (23, figure 7-42).

(3) Provide a suitable container to catch fluid when disconnecting tube (22) from solenoid valve (23).

**7-240. E M REMOVAL - SOLENOID VALVES P/N 204-076-504-3 FSCM 94641 P/N 1-U-1025-63 OR FSCM 16780 P/N 130027-5 (7, 8, AND 41, FIGURE 7-40).**

a. Remove solenoid valve (6, figure 7-42) as follows:

(1) Remove right fuselage access panel (17, figure 2-3).

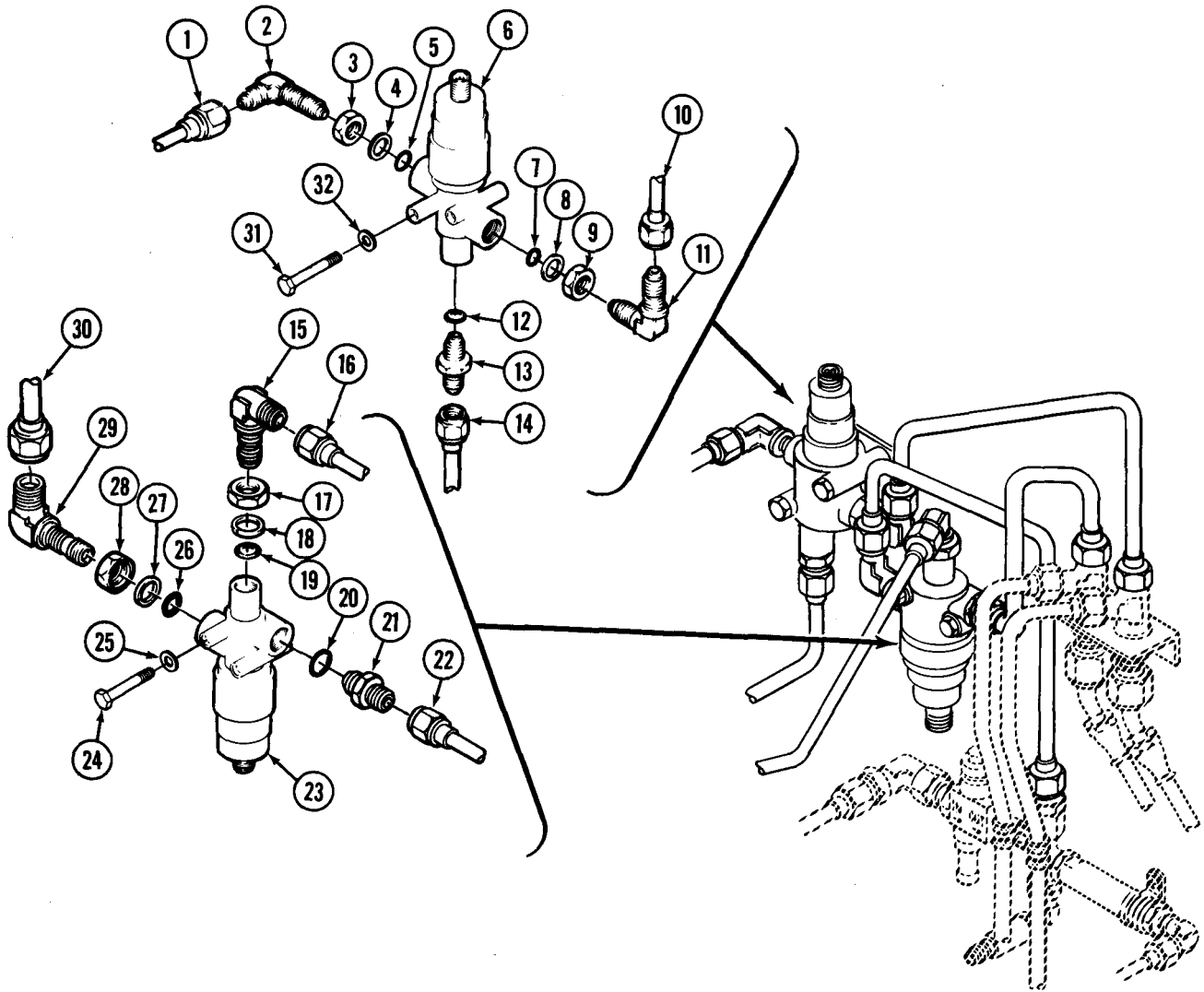

- |  |   |   |
|--|---|---|
| <ul style="list-style-type: none"> <li>1. Tube</li> <li>2. Elbow</li> <li>3. Nut</li> <li>4. Ring (backup)</li> <li>5. Packing</li> <li>6. Solenoid valve P/N 204-076 -504-3<br/>FSCM 94641 P/N 1-U-1025-63<br/>or FSCM 16780 P/N 130027-5</li> <li>7. Packing</li> <li>8. Ring (backup)</li> <li>9. Nut</li> <li>10. Tube</li> <li>11. Elbow</li> </ul> | <ul style="list-style-type: none"> <li>12. Packing</li> <li>13. Fitting (union)</li> <li>14. Tube</li> <li>15. Elbow</li> <li>16. Tube</li> <li>17. Nuts (2)</li> <li>18. Rings (backup) (2)</li> <li>19. Packing</li> <li>20. Packing</li> <li>21. Fitting (union)</li> <li>22. Tube</li> <li>23. Solenoid valve P/N 204-076 -504-3<br/>FSCM 94641 P/N 1-U-1025-63<br/>or FSCM 16780 P/N 130027-5</li> </ul> | <ul style="list-style-type: none"> <li>24. Bolts (2)</li> <li>25. Washer (2)</li> <li>26. Packing</li> <li>27. Ring (backup)</li> <li>28. Nut</li> <li>29. Elbow</li> <li>30. Tube</li> <li>31. Bolts (2)</li> <li>32. Washers (2)</li> </ul> |
|--|---|---|

209076-65B

Figure 7-42. **E M** Solenoid Solenoid Valves P/N 204-076-504-3 - Installation (Sheet 1 of 2)



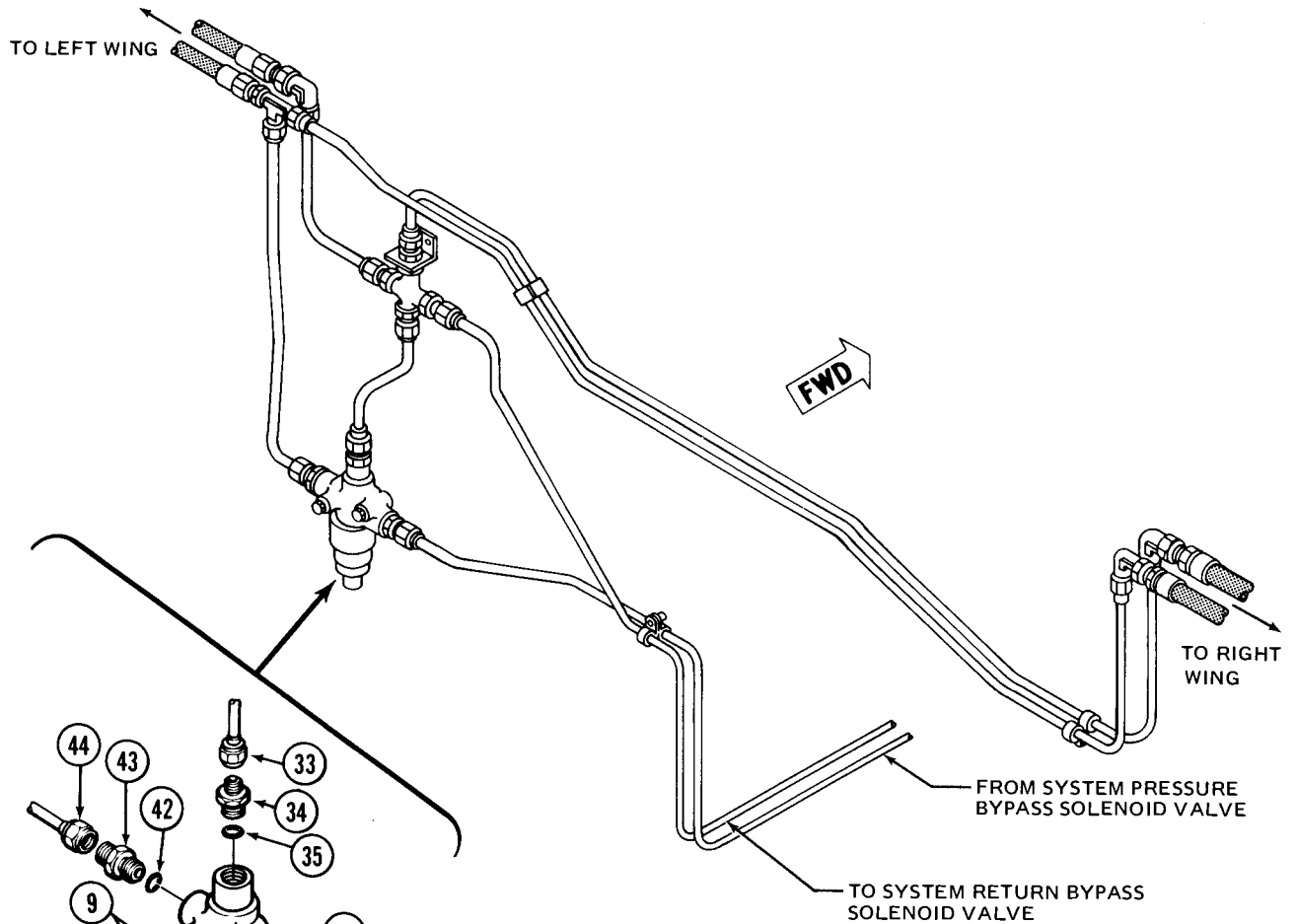

- 33. Tube
- 34. Fitting (union)
- 35. Packing
- 36. Packing
- 37. Fitting (union)
- 38. Tube
- 39. Solenoid valve P/N 204-076 -504-3  
FSCM 94641 P/N 1-U-1025-63  
or FSCM 16780 P/N 130027-5
- 40. Bolts
- 41. Washers
- 42. Packing
- 43. Fitting (union)
- 44. Tube

209076-66A

Figure 7-42. - Solenoid Valves P/N 204-076-504-3 - Installation (Sheet 2 of 2)

(4) Remove tube (22) from solenoid valve (23).

(5) Disconnect tubes (16 and 30) from solenoid valve (23).

(6) Remove two bolts (24) and two washers (25) attaching solenoid valve (23) to bulkhead and remove solenoid valve.

(7) Drain hydraulic fluid from solenoid valve (23) and remove fitting (21). Remove packing (20) from fitting (21).

(8) Loosen nut (17) and remove elbow (29) from solenoid valve (23). Remove packing (19), ring (backup) (18), and nut (17), from elbow (15).

(9) Loosen nut (28) and remove elbow (29) from solenoid valve (23). Remove packing (26), ring (backup) (27), and nut (28) from elbow (29).

(10) Install protective dust covers to open ports and electrical connector of solenoid valve (23) to prevent entry of foreign particles.

c. Remove solenoid valve (39, figure 7-42).

(1) Remove left fuselage panel (17, figure 2-3).

(2) Disconnect electrical connector from solenoid valve (39, figure 7-42).

(3) Provide a suitable container to catch fluid when disconnecting tube assemblies (33, 38, and 44).

(4) Disconnect tube assemblies (33, 38, and 44) from solenoid valve (39).

(5) Remove two bolts (40) and two washers (41) attaching solenoid valve (39) to bulkhead and remove solenoid valve. Cap all open lines.

(6) Drain fluid from solenoid valve (39) and remove fitting (34). Remove packing (35) from fitting. Discard packing.

(7) Remove fitting (37) from solenoid valve (39). Remove packing (36) from fitting. Discard packing.

(8) Remove fitting (43) from solenoid valve (39). Remove packing (42) from fitting. Discard packing.

**7-241. E M CLEANING - SOLENOID VALVES P/N 204-076-504-3 FSC 9461 P/N 1-U-1025-63 OR FSCM 16780 P/N 130027-5 (7, 8 AND 41, FIGURE 7-40).**

a. Clean assembled solenoid valves (7, 8 and 41) in same manner outlined in paragraphs 7-111).

b. Clean disassembled solenoid valves (7, 8, and 41) FSCM 94641 P/N 1-U-1025-63 in same manner outlined in paragraph 7-102.

**7-242. E M INSPECTION - SOLENOID VALVES P/N 204-076-504-3 FSCM 94641 P/N 1-U-1025-63 OR FSCM 16780 P/N 130027-5 (AVIM) (7, 8 AND 41, FIGURE 7-40).**

a. Inspect assembled solenoid valves (7, 8 and 41) as follows:

(1) Inspect electrical connector for bent or broken pins and damaged threads.

(2) Inspect ports for damaged threads.

(3) Inspect external surfaces for nicks, dents, and cracks. No cracked parts are acceptable.

b. Inspect disassembled solenoid valve FSCM 94641 P/N 1-U-1025-63 in same manner outlined in paragraph 7-103.

**7-243. E M REPAIR OR REPLACEMENT - SOLENOID VALVES P/N 204-076-504-3 FSCM 94641 P/N 1-U-1025-63 OR FSCM 16780 P/N 130027-5 (AVIM) (7, 8 AND 41, FIGURE 7-40).**

a. Inspect data plate on solenoid valve and determine whether valve is FSCM 94641 P/N 1-U-1025-63 or FSCM 16780 P/N 130027-5.

b. Replace solenoid valves FSCM 16780 P/N 130027-5 that fail to meet inspection requirements of paragraph 7-242.

c. Repair solenoid valves FSCM 94641 P/N 1-U-1025-63 that fail to meet inspection requirements. Use same procedure outlined in paragraphs 7-101 through 7-106.

**7-244. E M INSTALLATION - SOLENOID VALVES P/N 204-076-504-3 FSCM 94641 P/N 1-U-1025-63 OR FSCM 16780 P/N 130027-5 (7, 8, AND 41, FIGURE 7-40).**

a. Install solenoid valve (6, figure 7-42).

(1) Remove protective dust covers from solenoid valve. Flush solenoid valve with clean hydraulic fluid (C61 or C62).

(2) Apply a light film of hydraulic fluid (C61 or C62) to all packings, threads, and tube connectors prior to assembly of part, with the exception of bolts (31).

(3) Install nut (3), backup ring (4), and packing (5) on elbow (2). Thread elbow into PORT 1 of solenoid valve (6); position as shown and tighten nut (3).

(4) Install nut (9), backup ring (8), and packing (7) on elbow (11). Thread elbow into PORT 2 of solenoid valve (6); position as shown and tighten nut (9).

(5) Install packing (12) on fitting (13) and install fitting into PORT 3.

(6) Remove protective dust covers from tubes (1, 10 and 14).

(7) Buff mounting pads of bypass solenoid valve (6) to ensure good electrical bond. Position solenoid valve on bulkhead, as shown, and install two bolts (31) and two washers (32).

(8) Connect and torque tubes (1, 10 and 14) in accordance with table 7-4.

(9) Install electrical connector to solenoid valve (6) and secure with lockwire (C137).

(10) Fill reservoir to proper level. (Paragraph 7-6).

(11) Perform operational check of hydraulic system. (Paragraph 7-143). Refill reservoir.

(12) Install right access panel (17, figure 2-3).

b. Install solenoid valve (23, figure 7-42).

(1) Remove protective dust covers from solenoid valve (23), and drain preservative hydraulic

fluid from solenoid valve. Flush solenoid valve with clean hydraulic fluid (C61 or C62).

(2) Apply a light film of hydraulic fluid (C61 or C62) to all packings, threads and tube connectors prior to assembly of part, with the exception of bolts (24).

(3) Install nut (17), backup ring (18), and packing (19) on elbow (15). Thread elbow (15) into PORT 3; position elbow as shown and tighten nut (17).

(4) Install nut (28), backup ring (27), and packing (26) on elbow (29). Thread elbow (29) into PORT 1; position as shown and tighten nut (28).

(5) Install packing (20) on fitting (21) and install fitting into PORT 2.

(6) Remove protective dust covers from tubes (16, 22, and 30).

(7) Buff mounting pads of bypass solenoid valve (23) to ensure good electrical bond. Position solenoid valve on bulkhead as shown and install two bolts (24) and two washers (25).

(8) Install and torque tubes (16, 22 and 30) in accordance with table 7-4.

(9) Remove protective dust cover from solenoid valve (23). Install electrical connector on solenoid valve (23) and secure with lockwire (137).

(10) Fill reservoir to proper level. (Paragraph 7-6).

(11) Perform operational check of hydraulic system (Paragraph 7-146).

(12) Install right access panel (17, figure 2-3).

c. Install solenoid valve (39, figure 7-42).

(1) Remove protective dust covers from solenoid (39) and drain preservative hydraulic fluid from solenoid valve. Flush solenoid valve with clean hydraulic fluid (C61 or C62).

(2) Apply a light film of hydraulic fluid (C61 or C62) to all packings, threads, and tube connectors prior to assembly of part, with the exception of bolts (40).

(3) Install packing (35) on fitting (34) and install fitting into PORT 3 of solenoid valve (39).

(4) Install packing (42) on fitting (43) and install fitting into PORT 1 of solenoid valve (39).

(5) Install packing (36) on fitting (37) and install fitting into PORT 2 of solenoid valve (39).

(6) Remove protective dust covers from tubes (33, 38, and 44).

(7) Buff mounting pads of bypass solenoid valve (7) to ensure good electrical bond. Position solenoid valve on bulkhead as shown and install two bolts (40) and two washers (41).

(8) Connect and torque tubes (33, 38, and 44) in accordance with table 7-4.

(9) Install electrical connector on solenoid valve (39) and secure with lockwire (C137).

(10) Fill reservoir to proper level with clean hydraulic fluid (C61 or C62). (Paragraph 7-6).

(11) Perform operational check of hydraulic system (paragraph 7-146). Refill reservoir.

(12) Install left access panel (17, figure 2-3).

(13) Ensure that all air has been bled from system prior to next flight by cycling cyclic stick a minimum of 10 full cycles.

**7-245. E M SOLENOID VALVES P/N 209-076-023-1, FSCM 16780 P/N 15353 (17, 21, AND 37, FIGURE 7-40).**

**7-246. E M DESCRIPTION - SOLENOID VALVES P/N 209-076-023-1, FSCM 16780 P/N 15353 (17, 21, AND 37, FIGURE 7-40).**

Three, three-way, two-position solenoid valves (17, 21, and 37) are included in the hydraulic system to permit shutting off fluid circulation to any one of the three (SCAS) servo actuators. The solenoid valves are controlled by the pitch, roll, and yaw switches on the pilot (SCAS) control panel. See FO-2 (foldout 2) for view of hydraulic system schematic.

**Premaintenance Requirements For Hydraulic Solenoid Valves P/N 209-076-023-1 FSCM 16780 P/N 15353**

Conditions	Requirements
Model	AH-1S
Part No. or Serial No.	209-076-023-1 FSCM 16780 P/N 15353
Special Tools	None
Test Equipment	None
Support Equipment	(S1)(S2)
Minimum Personnel Required	One
Consumable Materials	(C61 or C62) (C112)
Special Environmental Conditions	None

**7-247. E M REMOVAL - SOLENOID VALVES P/N 209-076-023-1, FSCM 16780 P/N 15353 (17, 21, AND 37, FIGURE 7-40).**

a. Remove solenoid valve(16, figure 7-43) for fore and aft (SCAS) system as follows:

(1) Remove right access panel (17, figure 2-3).

(2) Disconnect electrical connector from solenoid valve (16, figure 7-43).

(3) Provide a suitable container to catch fluid seepage when disconnecting tube assemblies from solenoid valve (16).

(4) Disconnect tube assemblies (1, 2, 8, 19 and 30) from solenoid valve (16).

(5) Remove two nuts (15), two washers (14), two washers (7), two bolts (6), and remove solenoid (16) from bracket (24).

(6) Install protective dust covers to open connectors of tube assemblies (1, 2, 8, 19 and 30).

(7) Remove components from solenoid valve (16) as follows:

(a) Remove fitting (13) from solenoid valve (16).

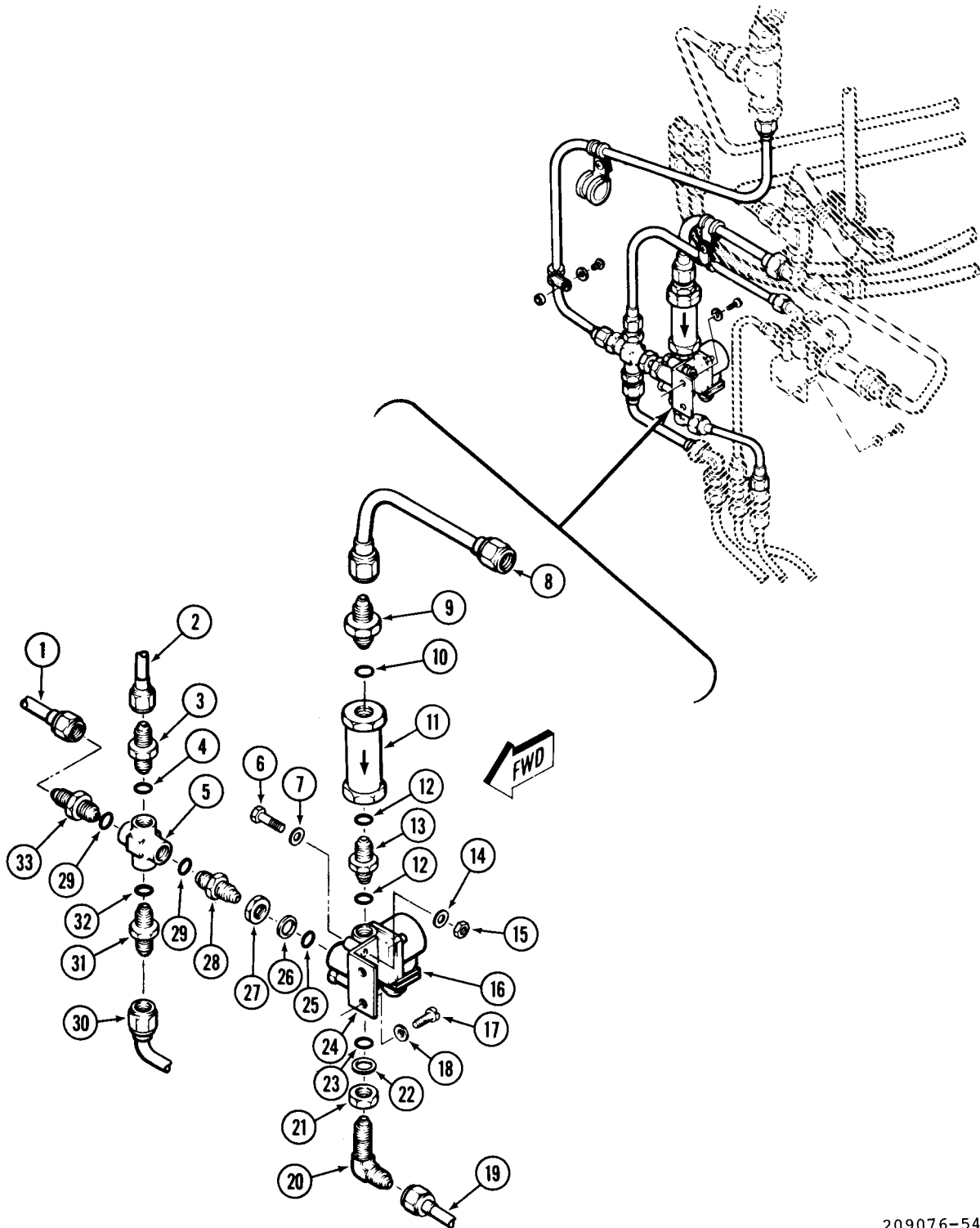

209076-54-1

Figure 7-43. **E M** Solenoid Valves (SCAS System) - Installation (Sheet 1 of 4)

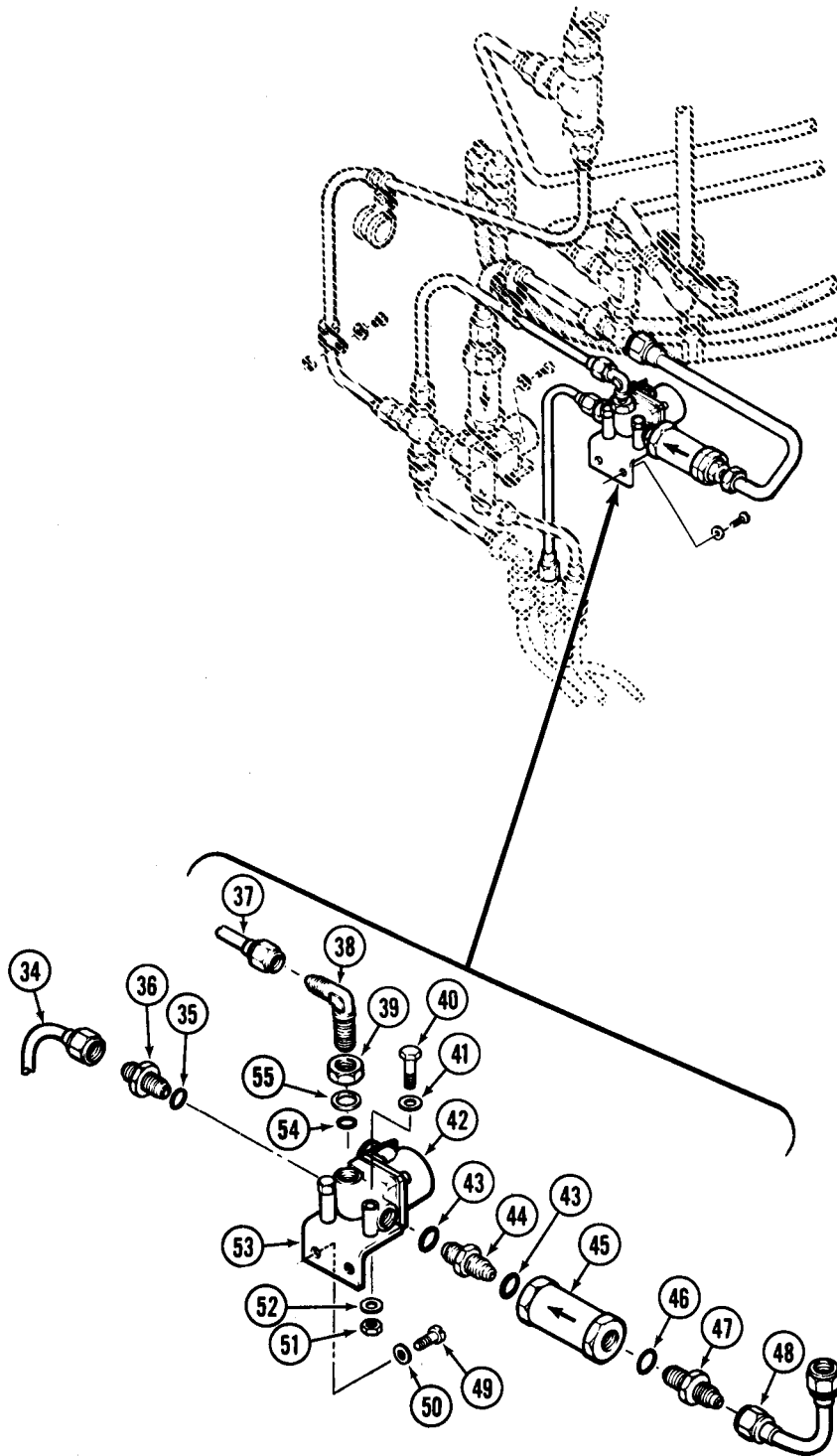

209076-54-2

Figure 7-43. **E M** Solenoid Valves (SCAS System) - Installation (Sheet 2 of 4)

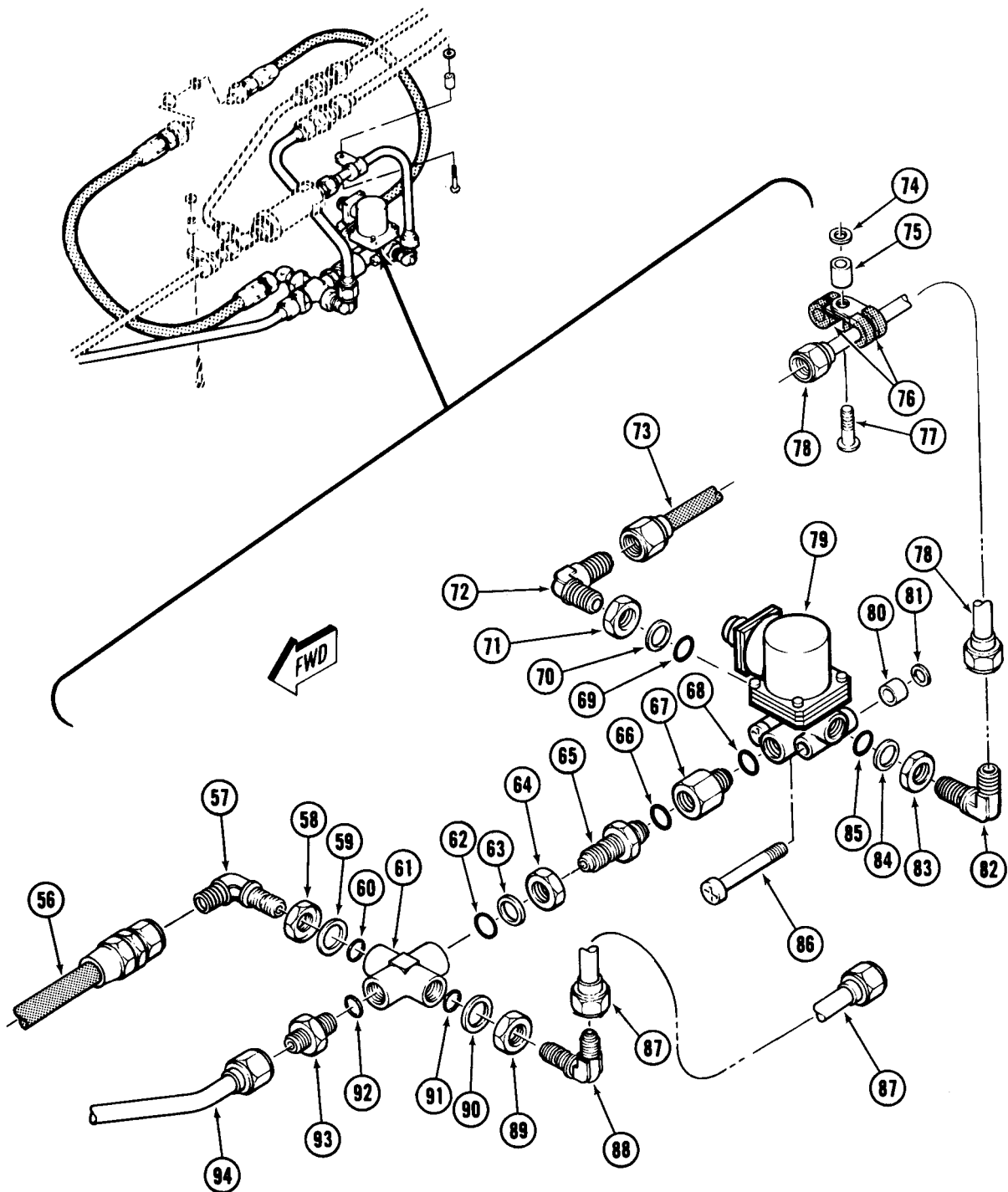

209076-54-3

Figure 7-43. **E M** Solenoid Valves (SCAS System) - Installation (Sheet 3 of 4)

- 1. Tube assembly
- 2. Tube assembly
- 3. Fitting
- 4. Packing
- 5. Tee
- 6. Bolt
- 7. Washer
- 8. Tube assembly
- 9. Fitting
- 10. Packing
- 11. Filter
- 12. Packing
- 13. Fitting
- 14. Washer
- 15. Nut
- 16. Valve P/N 209-076 -023-1  
FSCM 16780 P/N 15353
- 17. Screw
- 18. Washer
- 19. Tube assembly
- 20. Elbow
- 21. Nut
- 22. Ring (backup)
- 23. Packing
- 24. Bracket
- 25. Packing
- 26. Ring (backup)
- 27. Nut
- 28. Fitting
- 29. Packing
- 30. Tube assembly
- 31. Fitting
- 32. Packing
- 33. Fitting
- 34. Tube assembly
- 35. Packing
- 36. Fitting
- 37. Tube assembly
- 38. Elbow
- 39. Nut
- 40. Bolt
- 41. Washer
- 42. Solenoid valve P/N 209-076 -023-2  
FSCM 16780 P/N 15353
- 43. Packing
- 44. Fitting
- 45. Filter
- 46. Packing
- 47. Fitting
- 48. Tube assembly
- 49. Screw
- 50. Washer
- 51. Nut
- 52. Washer
- 53. Bracket
- 54. Packing
- 55. Ring (backup)
- 56. Hose assembly
- 57. Elbow
- 58. Nut
- 59. Ring (backup)
- 60. Packing
- 61. Tee
- 62. Packing
- 63. Ring (backup)
- 64. Nut
- 65. Fitting
- 66. Packing
- 67. Bushing
- 68. Packing
- 69. Packing
- 70. Ring (backup)
- 71. Nut
- 72. Elbow
- 73. Hose assembly
- 74. Washer
- 75. Spacer
- 76. Clamps
- 77. Screw
- 78. Tube assembly
- 79. Solenoid valve P/N 209-076 -023-1  
FSCM 16780 P/N 15353
- 80. Spacer
- 81. Washer
- 82. Elbow
- 83. Nut
- 84. Ring (backup)
- 85. Packing
- 86. Screw
- 87. Tube assembly
- 88. Elbow
- 89. Nut
- 90. Ring (backup)
- 91. Packing
- 92. Packing
- 93. Fitting
- 94. Tube assembly

209076-54-4A

Figure 7-43. **E M** Solenoid Valves (SCAS System) - Installation (Sheet 4 of 4)



**(b)** Remove fittings (9 and 13) from filter (11) and discard two packings (12) and packing (10). If filter (11) is not immediately being installed, install protective dust covers to open ports.

**(c)** Loosen nut (21) and remove elbow (20) from solenoid valve (16). Remove packing (23), (backup) ring (22) and nut (21) from elbow (20) and discard packing (23) and (backup) ring (22).

**(d)** Remove fittings (3, 31, and 33) from tee (5) and discard packings (4, 32 and 29).

**(e)** Loosen nut (27) and remove fitting (28), with tee (5), from solenoid valve (16).

**(f)** Remove packing (25), (backup) ring (26), and nut (27) from fitting (28). Discard packing (25) and (backup) ring (26).

**(g)** Remove fitting (28) from tee (5) and discard packing (29).

**b.** Remove solenoid valve (42, figure 7-43) for lateral (SCAS) system.

**(1)** Remove right access panel (17, figure 2-3).

**(2)** Disconnect electrical connector from solenoid valve (42, figure 7-43).

**(3)** Provide a suitable container to catch fluid seepage when disconnecting tube assemblies from solenoid valve (42).

**(4)** Disconnect tube assemblies (34, 37, and 48) from solenoid valve (42).

**(5)** Remove two nuts (51), two washers (52), two washers (41), two bolts (40) and remove solenoid valve (42) from bracket (53).

**(6)** Install protective dust covers on open connectors of tube assemblies (34, 37, and 48).

**(7)** Remove components from solenoid valve (42) as follows:

**(a)** Remove fittings (36) from solenoid valve (42) and discard two packings (35).

**(b)** Loosen nut (39) and remove elbow (38) from solenoid valve (42). Remove packing (54), (backup) ring (55) and nut (39) from elbow (38) and discard packing (54) and (backup) ring (55).

**(c)** Remove fitting (44), with filter (45), from solenoid valve (42). Remove fittings (44 and 47) from filter (45) and discard two packings (43) and packing (46).

**(d)** If filter (45) is not being installed immediately, install protective dust covers in open ports.

**c.** Remove solenoid valve (79, figure 7-43) for anti-torque (SCAS) system.

**(1)** Remove access panel (38, figure 2-3) from lower side of fuselage and provide a clean, dust free work area.

**(2)** Disconnect electrical connector from solenoid valve (79, figure 7-43).

**(3)** Provide a suitable container for catching fluid seepage when disconnecting hose assemblies (56 and 73) and tube assemblies (78, 87, and 94) from solenoid valve (79).

**(4)** Remove hose assembly (56) from elbow (57) and install protective dust cover to hose connector.

**(5)** Remove hose assembly (73) from elbow (72) and install protective dust cover to hose connector.

**(6)** Remove screw (77), spacer (75), washer (74) and clamp (76).

**(7)** Remove tube assembly (78) from elbow (82) and install protective dust covers to connectors of tube assembly.

**(8)** Disconnect tube assembly (87) from elbow (88).

**(9)** Disconnect tube assembly (94) from fitting (93).

**(10)** Remove two screws (86), two spacers (80), two washers (81) and remove solenoid valve (79).

**(11)** Install protective dust covers to connectors of tube assemblies (87 and 94).

**(12)** Remove components from solenoid valve (79) as follows:

**(a)** Loosen nut (71) and remove elbow (72) from solenoid valve (79). Remove packing (69),

(backup) ring (70) and nut (71) from elbow (72). Discard packing (69) and (backup) ring (70).

(b) Loosen nut (83) and remove elbow (82) from solenoid valve (79). Remove packing (85), (backup) ring (84) and nut (83) from elbow (82). Discard packing (85) and (backup) ring (84).

(c) Remove bushing (67), with tee (61) from solenoid valve (79).

(d) Remove bushing (67) from fitting (65) and discard packings (66 and 68).

(e) Remove fitting (93) from tee (61) and discard packing (92).

(f) Loosen nut (64) and remove fitting (65) from tee (61). Remove packing (62), (backup) ring (63) and nut (64) from fitting (65). Discard packing (62) and (backup) ring (63).

(g) Loosen nut (89) and remove elbow (88) from tee (61). Remove packing (91), (backup) ring (90) and nut (89) from elbow (88). Discard packing (91) and (backup) ring (90).

(h) Loosen nut (58) and remove elbow (57) from tee (61). Remove packing (60), (backup) ring (59) and nut (58) from elbow (57). Discard packing (60) and (backup) ring (59).

**7-248. E M CLEANING - SOLENOID VALVES P/N 209-076-023-1, FSCM 16780 P/N 15353 (17, 21, AND 37, FIGURE 7-40).**



Cleaning solvent is flammable and toxic. Provide adequate ventilation. Avoid Prolonged breathing of solvent vapors and contact with skin or eyes. Eye protection is required when using compressed air.



To prevent damaging internal components, do not submerge solenoid valve in solvent. Cap open ports prior to cleaning.

a. Clean solenoid valves (17, 21 and 37) with clean cloths dampened with solvent (C112). Use a soft bristle brush and a piece of soft copper wire may be required to remove stubborn deposits of dirt/oil from external surfaces.

b. Allow to air dry or blow dry using clean filtered compressed air.

**7-249. E M INSPECTION - SOLENOID VALVES P/N 209-076-023-1 FSCM 16780 P/N 15353 (17, 21 AND 37, FIGURE 7-40).**

a. Inspect electrical connector for bent or broken pins and damaged threads.

b. Inspect ports for damaged threads.

c. Inspect external surfaces for nicks, dents and cracks. No cracks are acceptable.

**7-250. E M REPAIR OR REPLACEMENT - SOLENOID VALVES P/N 209-076-023-1, FSCM 16780 P/N 15353 (17, 21 AND 37, FIGURE 7-40).**

a. Replace solenoid valves (17, 21 and 37) that fail to meet inspection requirements of paragraph 7-249.

b. Refer to paragraphs 7-247 and 7-251 for removal and installation instructions.

**7-251. E M INSTALLATION - SOLENOID VALVES P/N 209-076-023-1, FSCM 16780 P/N 15353 (17, 21, AND 37, FIGURE 7-40).**

a. Install solenoid valve (16, figure 7-43) for fore and aft (SCAS) system as follows:

(1) Remove protective dust covers from solenoid valve (16) and drain preservative hydraulic fluid from solenoid valve. Flush solenoid valve with clean hydraulic fluid (C61 or C62).

(2) Apply a light film of hydraulic fluid (C61 or C62) to all packings, threads and tube connectors prior to assembly of part with the exception of bolts (17).

(3) Install two packings (12) on fitting (13) and install fitting into PRESS port of solenoid valve (16).

**(4)** Position filter (11), with directional flow arrow pointing toward PRESS port, and install filter to fitting (13).

**(5)** Install packing (10) on fitting (9) and install fitting on filter (11).

**(6)** Install nut (21), backup ring (22), and packing (23) on elbow (20). Position and install elbow into CYL port of solenoid valve (16).

**(7)** Install packing (29), nut (27), backup ring (26) and packing (25) on fitting (28). Install fitting to tee (5).

**(8)** Install packing (29) on fitting (33) and install fitting to tee (5).

**(9)** Install packing (32) to fitting (31) and install fitting to tee (5).

**(10)** Thread fitting (28) into RET port of solenoid valve (16), position tee (5) as shown and tighten nut (27).

**(11)** Remove protective dust covers from tube assemblies (1, 8, 19, and 30).

**(12)** Buff mounting pads of solenoid valve to ensure good electrical bond. Position solenoid valve (16) to bracket (24) and install two bolts (6), two washers (7), two washers (14), and two nuts (15).

**(13)** Install tube assemblies (1, 8, 19, and 30) on solenoid valve (16) and torque tube connectors in accordance with torque requirements outlined in table 7-4.

**(14)** Connect electrical connector to solenoid valve (16).

**(15)** Fill reservoirs to proper level with clean hydraulic fluid (C61 or C62) (paragraph 7-6).

**(16)** Perform operational check of fore and aft cyclic (SCAS) actuator and bleed hydraulic system (paragraph 7-146). Refill reservoirs.

**b.** Install solenoid valve (42, figure 7-43) for lateral (SCAS) system.

**(1)** Remove protective dust covers from solenoid valve (42) and drain preservative hydraulic fluid from solenoid valve. Flush solenoid valve with clean hydraulic fluid (C61 or C62).

**(2)** Apply a light film of hydraulic fluid (C61 or C62) to all packings, threads and tube connectors prior to assembly of parts with the exception of bolts (49).

**(3)** Install two packings (43) on fitting (44) and install fitting into PRESS port of solenoid valve (42).

**(4)** Position filter (45), with directional flow arrow pointing toward PRESS port and install filter to fitting (44).

**(5)** Install packing (46) to fitting (47) and install fitting to filter (45).

**(6)** Install packing (35) to fitting (36) and install fitting to CYL port of solenoid valve (42).

**(7)** Install nut (39) backup ring (55), and packing (54) on elbow (38). Thread elbow into RETURN port of solenoid, position elbow as shown and tighten nut (39).

**(8)** Remove protective dust covers from tube assemblies (34, 37, and 48).

**(9)** Buff mounting pads of solenoid valve to ensure good electrical bond. Position solenoid valve (42) to bracket (53) and install two bolts (40), two washers (41), two washers (52) and two nuts (51).

**(10)** Install tube assemblies (34, 37, and 48) to solenoid valve (42) and torque tube connectors in accordance with torque requirements outlined in table 7-4.

**(11)** Connect electrical connector to solenoid valve (16).

**(12)** Fill reservoirs to proper level with clean hydraulic fluid (C61 or C62) (paragraph 7-6).

**(13)** Perform operational check of lateral cyclic (SCAS) actuator and bleed hydraulic system (paragraph 7-146). Refill reservoirs.

**c.** Install solenoid valve (79, figure 7-43), for anti-torque (SCAS) system.

**(1)** Remove protective dust covers from solenoid valve (79) and drain preservative hydraulic fluid from bypass solenoid valve. Flush solenoid valve with clean hydraulic fluid (C61 or C62).

(2) Apply a light film of hydraulic fluid (C61 or C62) to all packings, threads and tube connectors prior to assembly of parts with the exception of bolts (86).

(3) Install nut (64), backup ring (63) and two packings (62 and 66) on fitting (65) and install fitting to bushing (67).

(4) Install packing (68) on bushing (67) and install bushing into RET port of solenoid valve (79).

(5) Install packing (92) on fitting (93) and install fitting to tee (61).

(6) Install nut (58) backup ring (59) and packing (60) on elbow (57). Thread elbow into tee (61), position elbow as shown, and tighten nut (58).

(7) Install nut (89) backup ring (90), and packing (91) on elbow (88). Thread elbow into tee (61), position elbow as shown, and tighten nut (89).

(8) Thread fitting (65) into tee (61), position tee as shown, and tighten nut (64).

(9) Install nut (71), backup ring (70), and packing (69) on elbow (72). Thread elbow into CYL port of solenoid valve (79), position elbow as shown, and tighten nut (71).

(10) Install nut (83) backup ring (84), and packing (85) on elbow (82). Thread elbow into PRESS port of solenoid valve (79), position elbow as shown, and tighten nut (83).

(11) Remove protective dust covers from tube assemblies (78, 87, and 94).

(12) Buff mounting pads to solenoid valve to ensure good electrical bond. Position solenoid valve (79) on bracket and install two screws (86), two spacers (80) and two washers (81), as shown.

(13) Install tube assemblies (78, 87, and 94) on solenoid valve (79). Refer to table 7-4 for torque requirements of tube connectors.

(14) Remove protective dust covers from hose assemblies (56 and 73) and install hose assemblies on elbows (57 and 72). Torque hose connectors in accordance with torque requirements outlined in table 7-4.

(15) Install clamp (76), screw (77), spacer (75), and washer (74) as shown.

(16) Connect electrical connector to solenoid valve (79).

(17) Using hydraulic fluid dispenser (S1), fill reservoirs to proper level with clean hydraulic fluid (C61 or C62) (paragraph 7-6).

(18) Perform operational check of directional (SCAS) actuator and bleed hydraulic system (paragraph 7-146). Refill reservoir.

### 7-252. **E M** SERVO ACTUATOR (ELECTROHYDRAULIC) - ARMAMENT WING PYLON.

### 7-253. **E M** DESCRIPTION - SERVO ACTUATOR (ELECTROHYDRAULIC) - ARMAMENT WING PYLON.

The armament wing pylon (electro-hydraulic) servo actuator on **E** and **M** coded helicopters are similar to armament wing pylon (Electrohydraulic) servo actuators used on **P** coded helicopters (paragraph 7-127).

### 7-254. **E M** REMOVAL - SERVO ACTUATOR (ELECTROHYDRAULIC) - ARMAMENT WING PYLON.

Remove the armament wing pylon (electrohydraulic) servo actuator using same procedures outlined for **P** coded helicopters (paragraph 7-128).

### 7-255. **E M** DISASSEMBLY - SERVO ACTUATOR (ELECTROHYDRAULIC) - ARMAMENT WING PYLON. (AVIM)

Disassemble the armament wing pylon (electrohydraulic) servo actuator using the same procedures outlined for **P** coded helicopters (paragraph 7-129).

### 7-256. **E M** CLEANING - SERVO ACTUATOR (ELECTROHYDRAULIC) - ARMAMENT WING PYLON.

Clean the armament wing pylon (Electrohydraulic) servo actuator using the same procedures outlined for **P** coded helicopters (paragraph 7-130).

**7-257. E M INSPECTION - SERVO ACTUATOR (ELECTROHYDRAULIC) - ARMAMENT WING PYLON.**

Inspect the armament wing pylon (Electrohydraulic) servo actuator using the same procedures outlined for **P** coded helicopters (paragraph 7-131).

**7-258. E M REPAIR OR REPLACEMENT - SERVO ACTUATOR (ELECTROHYDRAULIC) - ARMAMENT WING PYLON. (AVIM)**

Repair or replace the armament wing pylon (Electrohydraulic) servo actuator using the same procedures outlined for **P** coded helicopters (paragraph 7-132).

**7-259. E M ASSEMBLY - SERVO ACTUATOR (ELECTROHYDRAULIC) - ARMAMENT WING PYLON. (AVIM)**

Assemble the armament wing pylon (Electrohydraulic) servo actuator using the same procedures outlined for **P** coded helicopters (paragraph 7-133).

**7-260. E M FUNCTIONAL TEST - SERVO ACTUATOR (ELECTROHYDRAULIC) - ARMAMENT WING PYLON,**

The armament wing pylon (Electrohydraulic) servo actuator functional test is similar to that performed on **P** coded helicopters (paragraph 7-134).

**7-261. E M LOCK PRESSURE TEST - SERVO ACTUATOR (ELECTROHYDRAULIC) - ARMAMENT WING PYLON.**

The armament wing pylon (Electrohydraulic) servo actuator lock pressure test is similar to that performed on **P** coded helicopters (paragraph 7-135).

**7-262. E M UNLOCK PRESSURE TEST - SERVO ACTUATOR (ELECTROHYDRAULIC) - ARMAMENT WING PYLON.**

The armament wing pylon (Electrohydraulic) servo actuator unlock pressure test is similar to that performed on **P** coded helicopters (paragraph 7-136).

**7-263. E M BACKLASH TEST - SERVO ACTUATOR (ELECTROHYDRAULIC) - ARMAMENT WING PYLON. (AVIM)**

The armament wing pylon (Electrohydraulic) servo actuator backlash test is similar to that performed on **P** coded helicopters (paragraph 7-137).

**7-264. E M PROOF PRESSURE TEST - SERVO ACTUATOR (ELECTROHYDRAULIC) - ARMAMENT WING PYLON. (AVIM)**

The armament wing pylon (Electrohydraulic) servo actuator proof pressure test is similar to that performed on **P** coded helicopters (paragraph 7-138).

**7-265. E M LEAKAGE TESTS - SERVO ACTUATOR (ELECTROHYDRAULIC) - ARMAMENT WING PYLON. (AVIM)**

The armament wing pylon (Electrohydraulic) servo actuator leakage tests are similar to those used on **P** coded helicopters (paragraph 7-139).

**7-266. E M INTERNAL LEAKAGE TESTS - SERVO ACTUATOR (ELECTROHYDRAULIC) - ARMAMENT WING PYLON. (AVIM)**

The armament wing pylon (Electrohydraulic) servo actuator internal leakage tests are similar to those performed on **P** coded helicopters (paragraph 7-140).

**7-267. E M SERVO VALVE FREQUENCY RESPONSE - SERVO ACTUATOR (ELECTROHYDRAULIC) - ARMAMENT WING PYLON. (AVIM)**

The armament wing pylon (Electrohydraulic) servo valve frequency response test is similar to that performed on **P** coded helicopters (paragraph 7-141).

**7-268. E M INSTALLATION - SERVO ACTUATOR (ELECTROHYDRAULIC) - ARMAMENT WING PYLON.**

Install the armament wing pylon (Electrohydraulic) servo actuator using the same procedures outlined for **P** coded helicopters (paragraph 7-142).

**7-269. E M HYDRAULIC LINE FABRICATION. (AVIM)**

Refer to Appendix D.



## CHAPTER 8

### INSTRUMENT SYSTEMS

#### SECTION I. INSTRUMENT MAINTENANCE

##### 8-1. INSTRUMENT MAINTENANCE.

instrument panel by the following general procedures.

##### 8-2. DESCRIPTION - INSTRUMENT MAINTENANCE.

**P E** The following general instrument maintenance procedures are applicable to all instruments mounted in either the pilot or gunner instrument panel (figure 8-1 ). **M** Refer to Appendix F for equipment location chart.

##### NOTE

**Removal of turbine gas temperature (TGT) and tachometer in the gunner cockpit will require removal of gunner sight hand control.**

##### 8-3. CLEANING - INSTRUMENT MAINTENANCE.

a. Clean panel and instrument cover glasses with a suitable soft, lint-free cloth.

b. **M** Clean head-up display (HUD) combiner glasses with a soft, lint-free cloth.

a. Ensure all electrical power is OFF.

b. Disconnect electrical leads and/or instrument piping from back of panel. Necessary access may be made through side panels to pilot instrument panel, and at back of gunner instrument panel.

c. Protect ends of electrical leads with electrical tape (C121). Cap open piping and openings on instrument.

d. Remove mounting screws, or loosen mounting clamp screw. Remove instrument.

##### 8-4. INSPECTION - INSTRUMENT MAINTENANCE.

a. Inspect for loose, cracked, or broken cover glasses.

b. **M** Inspect HUD combiner glasses in accordance with TM 9-1270-220-13.

c. Inspect for proper and secure mounting.

d. Inspect range markings and decals for completeness and legibility in accordance with TM 55-1520-236-10.

e. Inspect for proper operation.

##### 8-6. REPAIR OR REPLACEMENT - INSTRUMENT MAINTENANCE.

a. Replace any required panel decals which are not clearly legible.

b. Replace any instrument if cover glass is loose, cracked or broken, or when found to be unserviceable.

##### 8-5. REMOVAL - INSTRUMENT MAINTENANCE.

Remove any instrument from pilot or gunner

##### 8-7. INSTALLATION - INSTRUMENT MAINTENANCE.

Install any instrument in pilot or gunner instrument panel by the following general procedures.

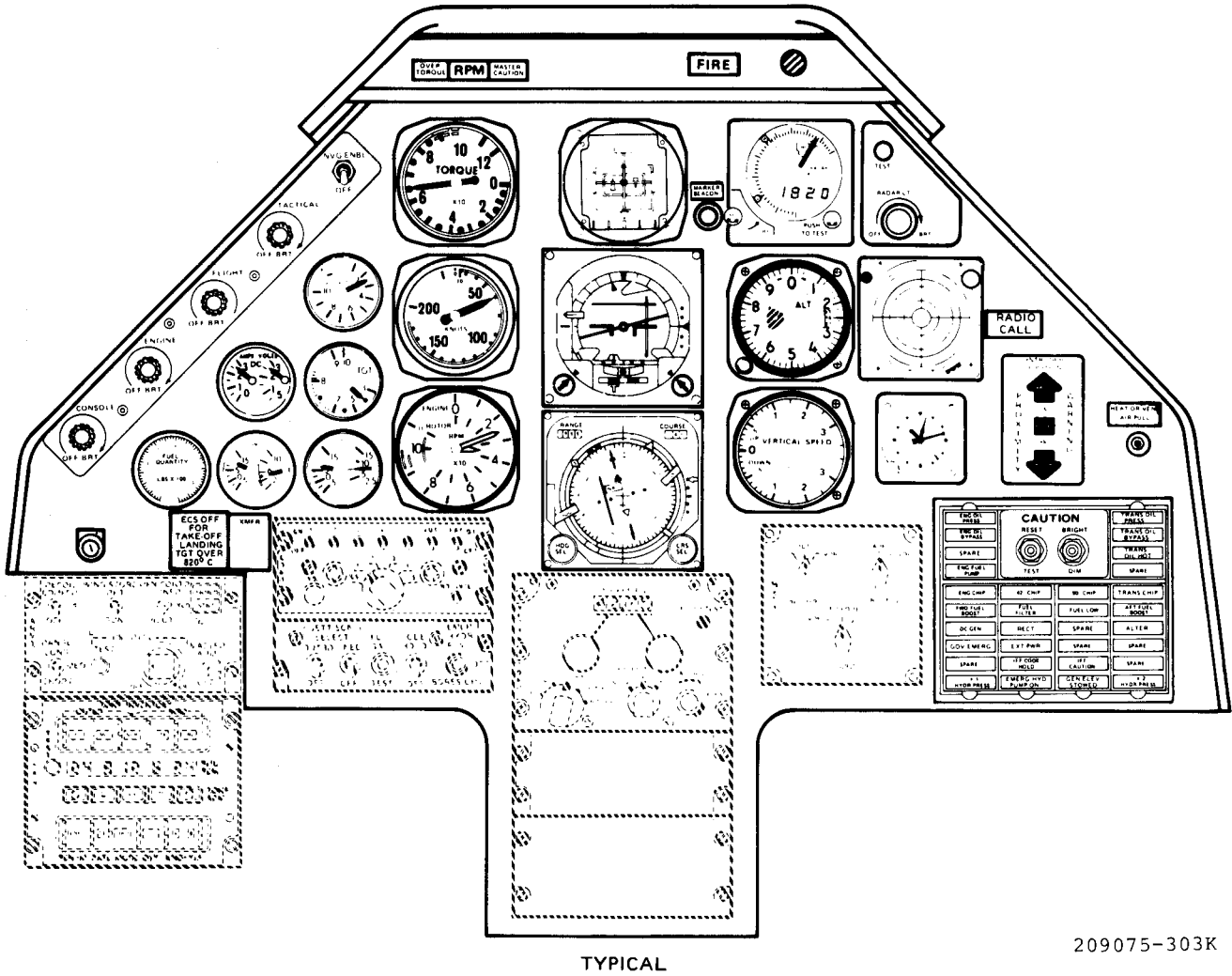

209075-303K

Figure 8-1. **P** Instrument Systems Equipment Location (Sheet 1 of 5)



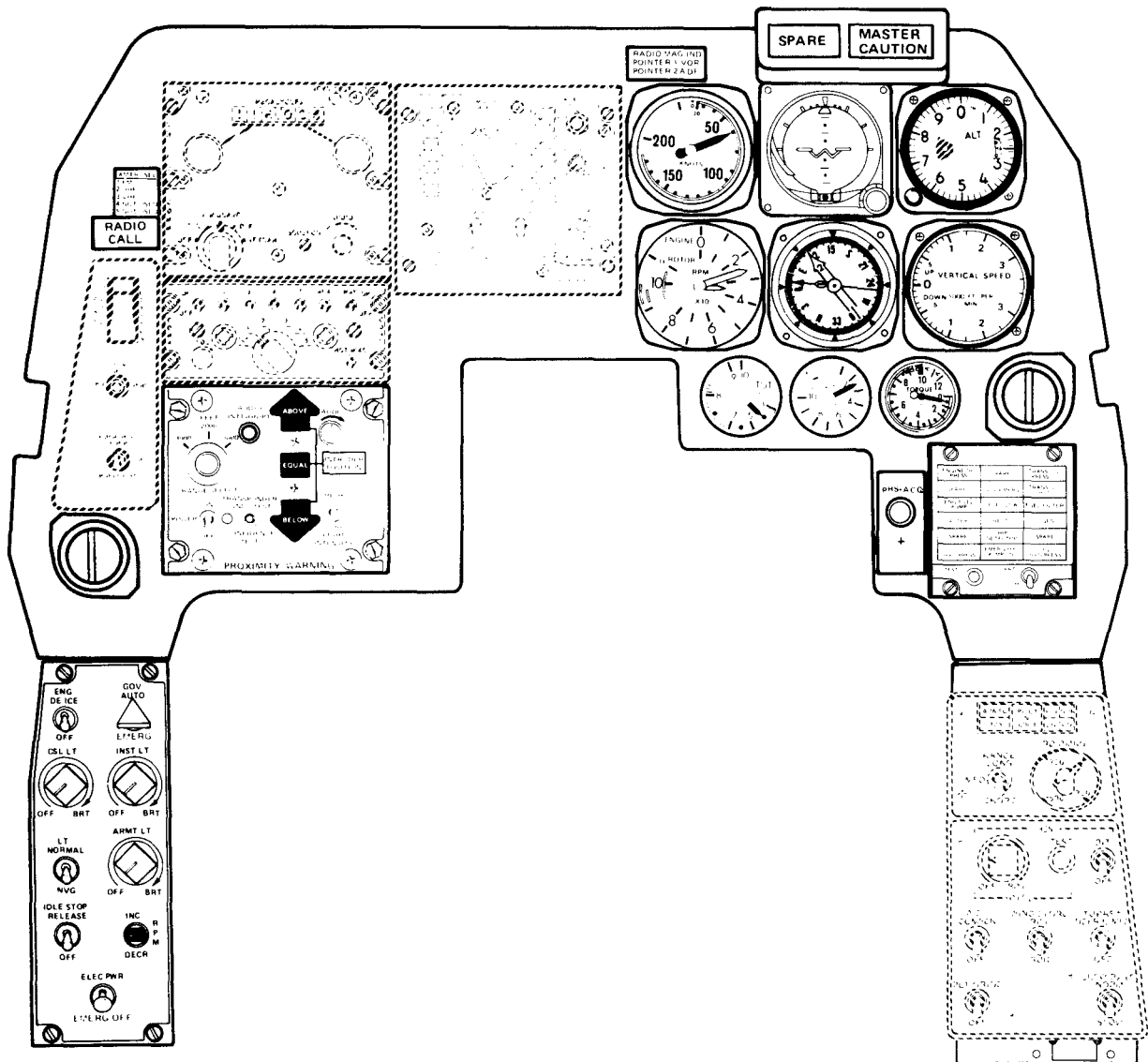

TYPICAL

209075-387D

Figure 8-1. **PE** Instrument Systems Equipment Location (Sheet 2 of 5)

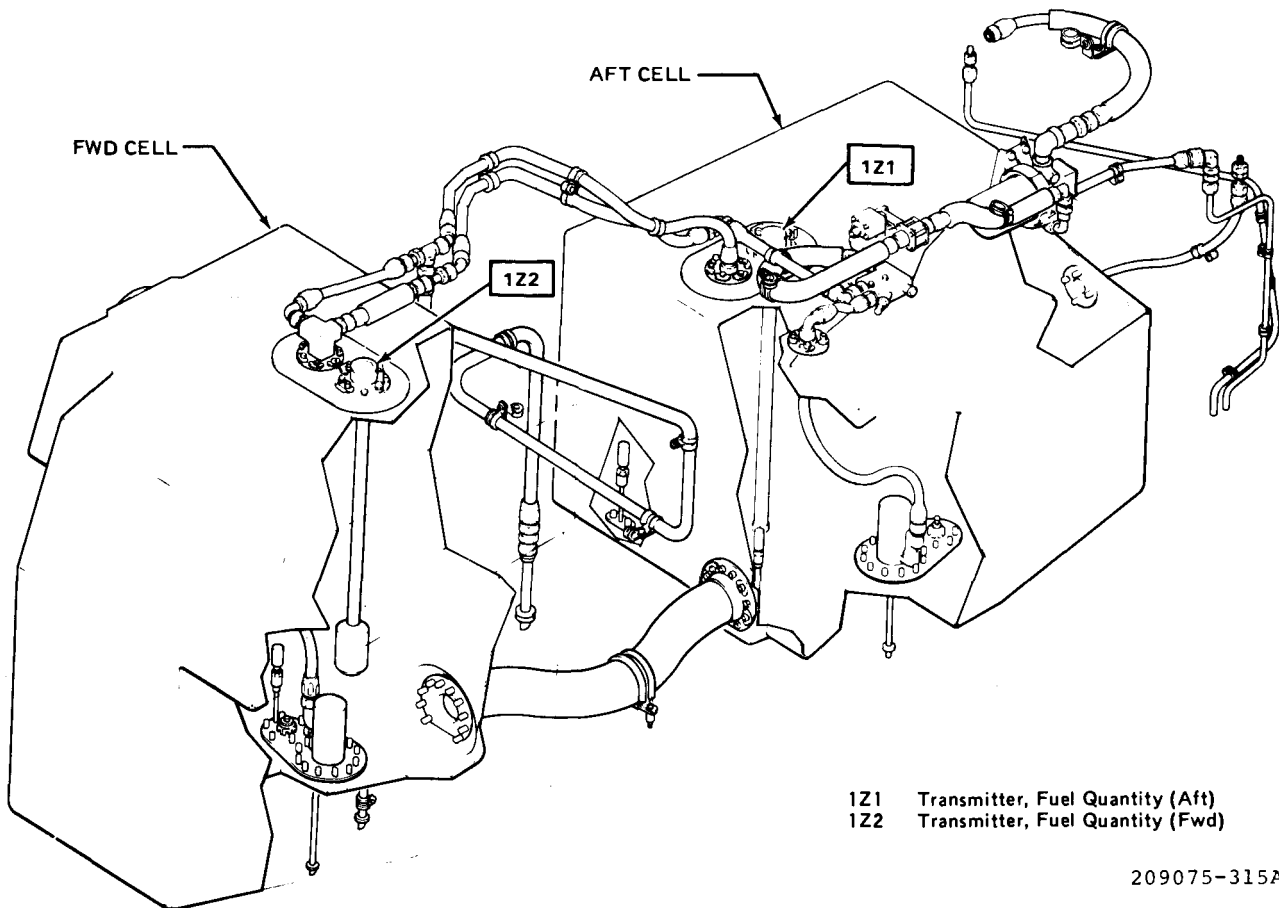
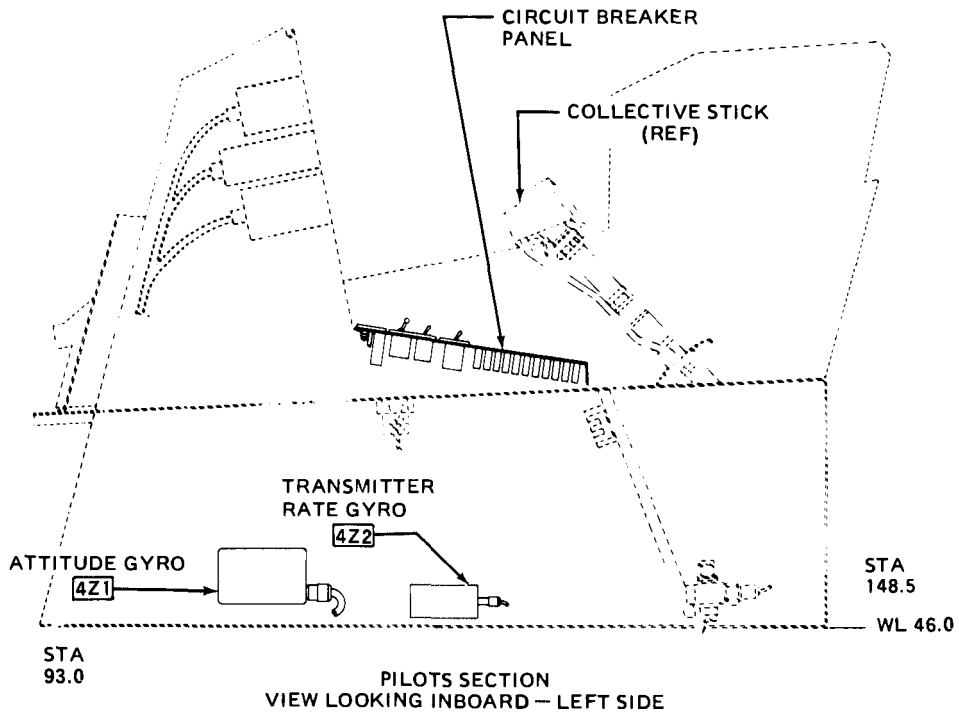

209075-315A

Figure 8-1. **P E** Instrument Systems Equipment Location (Sheet 3 of 5)

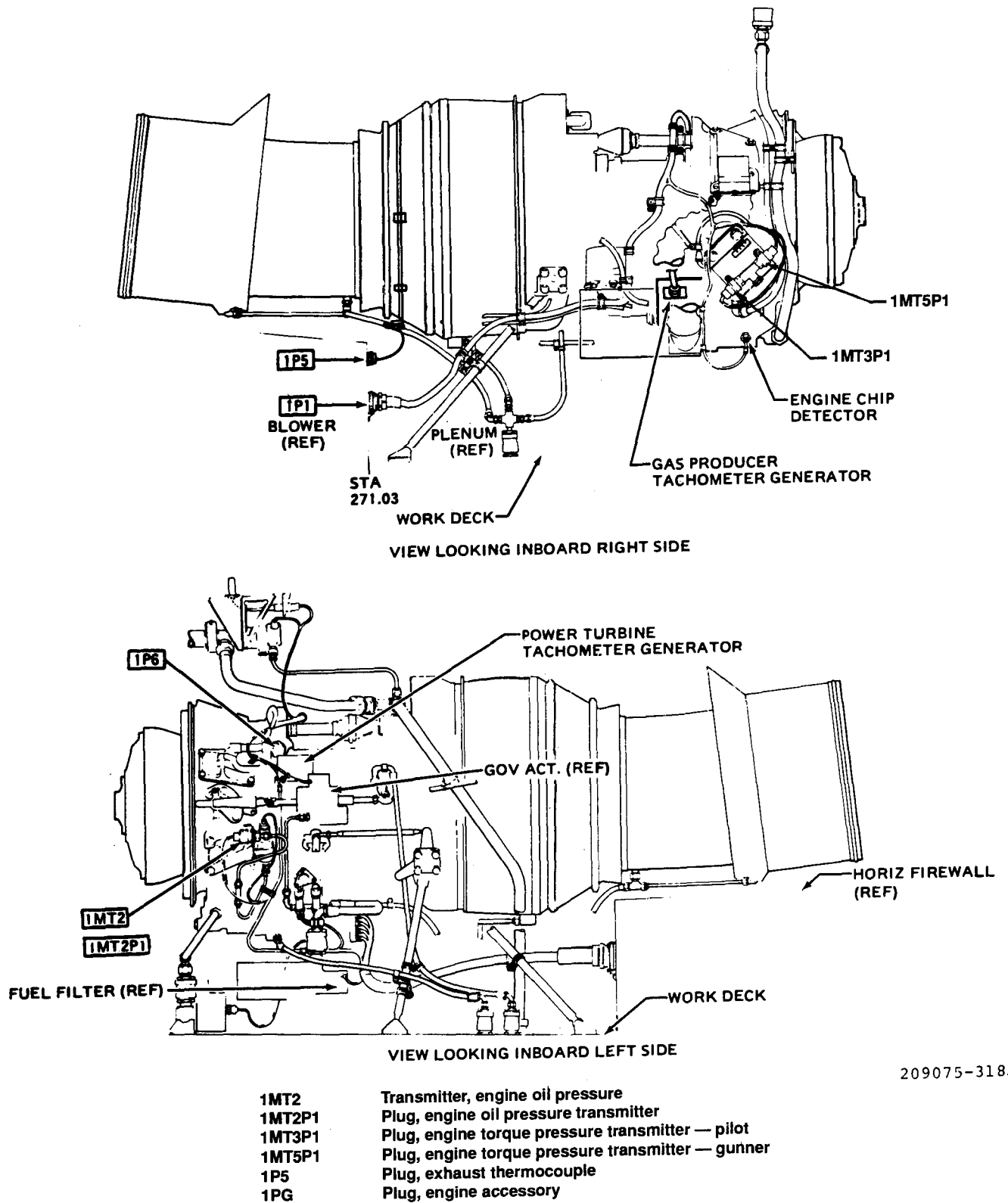

209075-318A

Figure 8-1. **P E** Instrument Systems Equipment Location (Sheet 4 of 5)

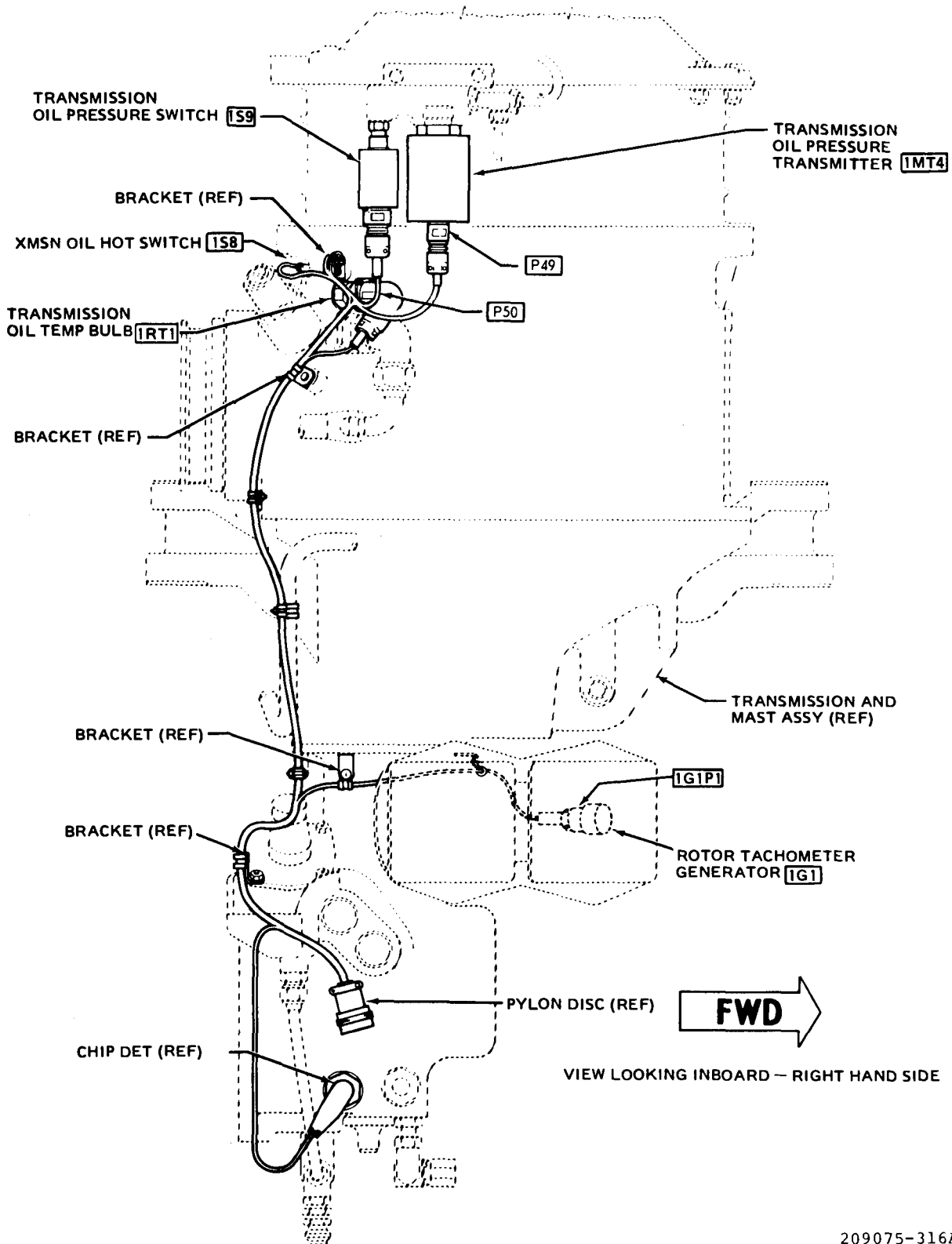

209075-316A

Figure 8-1. **P E** Instrument Systems Equipment Location (Sheet 5 of 5)

Do not tighten dampers more than necessary to hold Instrument as excessive tension may deform Instrument case, causing erroneous reading.

**NOTE**

An adapter cable is required to match aircraft connector when replacing the ID-2.501/A RMI with the ID-250/A. Refer to Appendix D, Figure D-373.

- a. Position instrument in panel. Install mounting screws, or tighten screw of mounting damp.



When connecting electrical plugs to dual tachometer Indicator, ensure that plugs are connected to correct recap tacle.

- b. Remove protective cape or covers, as necessary. Connect electrical leads and/or instrument

pipng. Use silicone compound (C110) on threads of nylon fittings.

- c. Torque coupling nuts fingertight.
- d. Check operation of instrument.

**8-8. INSTRUMENT PREMAINTENANCE REQUIREMENTS.**

**8-9. DESCRIPTION — INSTRUMENT PREMAINTENANCE REQUIREMENTS.**

Throughout this chapter, unless otherwise specified, instrument maintenance, testing and troubleshooting procedures will utilize only tools and equipment contained in electrical equipment toolkit (T20); multimeter (T2); turbine temperature indicating system test set, (T68); field calibration unit (T79); and resistance bridge (T62 or T63), or equivalent.

**NOTE**

Multimeter (T3) is an acceptable substitute for resistance bridge (T62 or T63).

**SECTION II. ENGINE INSTRUMENTS**

**8-10. ENGINE INSTRUMENTS.**

**8-11. DESCRIPTION — ENGINE INSTRUMENTS.**

Engine instruments include the pilot and gunner torquemeter, pilot and gunner dual tachometer, pilot and gunner turbine gas temperature indicator, pilot engine oil temperature and pressure indoor, and pilot and gunner gas producer tachometer.

**8-12. TACHOMETER INDICATING SYSTEMS.**

**8-13. DESCRIPTION — TACHOMETER INDICATING SYSTEMS.**

The tachometer indicating systems are pilot dual tachometer, gunner dual tachometer, rotor tachometer generator, and power turbine tachometer generator as

one system; and pilot gas producer tachometer, gunner gas producer tachometer, and gas producer tachometer generator as the other system.

**8-14. TROUBLESHOOTING — TACHOMETER INDICATING SYSTEMS.**

- a. **PE** Use table 8-1 and perform necessary checks to isolate trouble. Refer to figure 8-1 for equipment location and paragraph F-9 in Appendix F for wiring diagram. Broken or shorted wiring is always a probable cause of malfunction or failure and has not been included.

- b. **M** Use table 8-1 and perform necessary checks to isolate trouble. Refer to paragraph F-9 in Appendix F for wiring diagram and equipment location chart. Broken or shorted wiring is always a probable cause of malfunction or failure and has not been included.

**NOTE**

Before you use this table, be sure you have performed all normal operational checks. If you have a malfunction which is not listed in this table, notify the next higher level of maintenance.

**Table 8-1 Troubleshooting Tachometer Indicating Systems**

---

**CONDITION**

**TEST OR INSPECTION**

**CORRECTIVE ACTION**

**Dual Tachometer**

**1. Tachometer has excessive scale error.**

**STEP 1. Determine if indicator is defective by substituting a known good indicator.**

**Replace indicator if defective (paragraph 8-1).**

**2. One of the pointers on pilot or gunner dual tachometer fails to respond.**

**STEP 1. Check for defective tach generator by substitution of known good tach generator.**

**Replace tach generator if defective (paragraph 8-23 or 8-31).**

**STEP 2. Check for defective tachometer by substitution of known good tachometer.**

**Replace tachometer if defective (paragraph 8-1).**

**STEP 3. Check for poor connection at indicator or generator.**

**Clean or tighten connections.**

**3. High or low reading on indicator, either constant or intermittent.**

**STEP 1. Determine if indicator is out of adjustment using procedure contained in paragraph 8-19, Functional Test.**

**Replace indicator if defective (paragraph 8-1).**

**4. Any pointer on either the pilot or gunner tachometer indicates backwards.**

**STEP 1. Check if wires are reversed at pins of tach generator plugs.**

**Remove plug and reverse wires.**

Table 8-1. Troubleshooting Tachometer Indicating Systems (Cont)

---

**CONDITION****TEST OR INSPECTION****CORRECTIVE ACTION****Gas Producer Tachometer**

1. Gas producer tachometer fails to respond.

STEP 1. Determine if tach generator is defective by substitution of known good tach generator.

**Replace tach generator if defective (paragraph 8-47).**

STEP 2. Determine if tachometer is defective by substitution of known good tachometer.

**Replace tachometer if defective (paragraph 8-39).**

2. Gas producer tachometer indicates incorrectly.

STEP 1. Determine if tach generator is defective by substitution of known good tach generator.

**Replace tach generator if defective (paragraph 8-47).**

STEP 2. Determine if tachometer is defective by substitution of known good tachometer.

**Replace tachometer if defective (paragraph 8-39).**

3. Gas producer tachometer indicates backwards.

STEP 1. Check if wires are reversed at pins of tach generator plug.

**Remove plug and reverse wires.**

---

**8-15. DUAL TACHOMETERS.****8-16. DESCRIPTION - DUAL TACHOMETERS.**

The pilot and gunner dual tachometers, each located on respective instrument panel, indicate percentage of rpm of both main rotor and engine output shaft. Each tachometer has a synchronous motor connected electrically to a separate tachometer generator. The system is energized from the 28 Vdc essential bus when DUAL TACH circuit breaker (1CB20) is closed. The rotor pointer indicates on inner scale of instrument and engine pointer indicates on outer scale. The pointers will be aligned when engine

and rotor speeds are synchronized in normal operation.

**8-17. CLEANING - DUAL TACHOMETERS.**

Clean dual tachometers in accordance with paragraph 8-3.

**8-18. INSPECTION - DUAL TACHOMETERS.**

Inspect dual tachometers in accordance with paragraph 8-4.

**8-19. FUNCTIONAL TEST - DUAL TACHOMETERS.**

stand and set controls according to instructions on cover of tester.

a. Disconnect plug (1G1P1) from rotor tachometer generator. Connect plug to the MASTER GENERATOR output plug on tachometer test set (T21). Energize test

b. Check that rotor tachometer portion of indicator indicates within tolerance of various check points in following chart:

INDICATOR PERCENT OF RPM	ROTOR RPM*	POWER TURBINE MINIMUM	TACHOMETER RPM** MAXIMUM
20	65	796	860.112-925
30	97	1226	1355
40	130	1656	1785
50	162	2086	2215
60	194	2559	2602
70	227	2989	3032
80	259	3419	3462
90	292	3849	3892
100	324	4279	4300.56-322
110	356	4709	4752

\*FOR REFERENCE ONLY  
\*\*USE RX1 RANGE

c. Disconnect plug (1G1P1) from test set (T21) and reconnect it to the rotor tachometer generator. Check that connector is properly mated and secure.

set controls according to test set instructions on cover of the test set.

d. Disconnect plug from power turbine tachometer generator. Connect plug to MASTER GENERATOR output plug on test set (T21). Energize test stand and

e. Check that the engine portion of indicator indicates within tolerance of various check points in following chart:

INDICATOR PERCENT OF RPM	ENGINE (N2) RPM*	POWER TURBINE MINIMUM	TACHOMETER RPM** MAXIMUM
20	1321	780	906
30	1981	1202	1328
40	2642	1623	1749
50	3302	2044	2107.38-2171
60	3962	2508	2550
70	4623	2929	2971
80	5283	3351	3393
90	5944	3772	3814
100	6604	4194	4214.76-4236
110	7264	4615	4857

\*FOR REFERENCE ONLY  
\*\*USE RX1 RANGE



f. Disconnect plug from test stand and reconnect it to the power turbine tachometer generator. Check that connector is properly mated and secure.

### 8-20. REMOVAL - DUAL TACHOMETERS.

Remove dual tachometers in accordance with paragraph 8-5.

### 8-21. REPAIR - DUAL TACHOMETERS.

Repair dual tachometers in accordance with paragraph 8-6.

### 8-22. INSTALLATION - DUAL TACHOMETERS.

Install dual tachometers in accordance with paragraph 8-7.

### 8-23. POWER TURBINE TACHOMETER GENERATOR.

### 8-24. DESCRIPTION - POWER TURBINE TACHOMETER GENERATOR.

The power turbine tachometer generator is mounted on the governor and tachometer drive gearbox on left upper side of engine, and is connected to the dual tachometer indicators on the instrument panels.

**P E** Refer to figure 8-1 for equipment location.

**M** Refer to paragraph F-9 in Appendix F for equipment location chart.

### 8-25. CLEANING - POWER TURBINE TACHOMETER GENERATOR.

a. Remove moisture and loose dirt with a clean, soft cloth.



**Cleaning solvent is flammable and toxic. Provide adequate ventilation. Avoid prolonged breathing of solvent vapors and contact with skin or eyes.**

b. Remove grease, fungus, and ground-in dirt with a clean, lint-free cloth dampened with dry cleaning solvent (C112).

c. Remove dirt from electrical connectors with a bristle brush.

### 8-26. INSPECTION - POWER TURBINE TACHOMETER GENERATOR.

a. Inspect tachometer generator case for cracks, excessive wear, or any visible damage.

b. Check connector for damaged or bent pins and cracked inserts.

c. After removal, check that rotor turns freely and there is no visible indication of excessive wear to bearings.

### 8-27. REMOVAL - POWER TURBINE TACHOMETER GENERATOR.

a. Open cowling on left side of engine.

b. Disconnect electrical receptacle, remove mounting nuts and washers and lift tachometer generator from engine.

### 8-28. REPAIR - POWER TURBINE TACHOMETER GENERATOR.

a. Replace tachometer generator if case is cracked or damaged.

b. Replace tachometer generator if rotor does not turn freely or for visible indication of excessive wear to bearings.

#### NOTE

**Replacement of power turbine tachometer generator will require testing the rpm limit warning system (paragraph 9-287).**

c. Repair damaged connectors.

### 8-29. FUNCTIONAL TEST - POWER TURBINE TACHOMETER GENERATOR - BENCH (AVIM).

a. Remove tachometer generator from helicopter and mount on tachometer test set (T67.1). Connect generator to the TEST GENERATOR INPUT. Operate testor according to instructions on cover and check voltage outputs of the tachometer generator. With a 40 ohm "Y" connected resistance and a shaft speed of 4200 rpm, check voltage output across each phase of the generator (A-B, A-C and B-C). The three voltage outputs should be  $21 \pm 0.5$  Vac.

b. Decrease generator speed to 1000 rpm with a 20 ohm "Y" connected resistance.

c. Check volage output of the three phases. Voltage should not go below 3.5 Vac.

d. Disconnect tachometer generator and remove from test set (T21).

e. Measure resistance of each phase (A-B, A-C, and B-C). At 25 degrees C (77 degrees F), the resistance should be between 15 AND 20 ohms. Each phase should be within one ohm of each other.

f. At completion of testing, install tachometer generator and connect electrical plug and check for proper mating and security.

### 8-30. INSTALLATION - POWER TURBINE TACHOMETER GENERATOR.

a. Position tachometer generator and gasket on studs and install mounting hardware.

b. Connect electrical receptacle and install cowl-ing.

#### NOTE

Coat tachometer generator shaft and pack mating splines of shaft in accessory drive gearbox 2/3 full with lubricant (C85).

### 8-31. ROTOR TACHOMETER GENERATOR.

### 8-32. DESCRIPTION - ROTOR TACHOME-TER GENERATOR.

The rotor tachometer generator is located on lower left side of the transmission. The generator is mounted on hydraulic pump and tachometer drive quill assembly and is connected to the dual tachometer indicators on the instrument panels. **P E** Refer to figure 8-1 for equipment location. **M** Refer to paragraph F-9 in Appendix F for equipment location chart.

### 8-33. CLEANING - ROTOR TACHOMETER GENERATOR.

Clean rotor tachometer generator in accordance with paragraph 8-25.

### 8-34. NSPECTION - ROTOR TACHOMETER GENERATOR.

Inspect rotor tachometer generator in accordance with paragraph 8-26.

### 8-35. REMOVAL - ROTOR TACHOMETER GEN-ERATOR.

a. Open cowling on left side of transmission.

b. Disconnect electrical receptacle, remove mounting nuts and washers, and lift rotor tachometer generator from helicopter.

### 8-36. REPAIR - ROTOR TACHOMETER GEN-ERATOR.

a. Replace tachometer generator if case is cracked or damaged.

b. Replace tachometer generator if rotor does not turn freely or for visible indication of wear to bearings.

#### NOTE

Replacement of rotor tachometer gener-ator will require testing the rpm limits warning system (paragraph 9-287).

### 8-37. FUNCTIONAL TEST - ROTOR TACHOME-TER GENERATOR - BENCH (AVIM).

Bench test rotor tachometer generator in accordance with paragraph 8-29.

### 8-38. INSTALLATION - ROTOR TACHOME-TER GENERATOR.

a. Apply a thin film of antiseize compound (C21) to tachometer generator splines and to mating splines in transmission.

b. Install rotor tachometer generator with electrical connector 180 degrees down. Secure with nuts and washers on four studs. Connect and lockwire (C137) electrical cable connector.

**8-39. GAS PRODUCER TACHOMETERS.**

**8-40. DESCRIPTION — GAS PRODUCER TACHOMETERS.**

The pilot and gunner gas producer tachometers are located on their respective instrument panels. They provide indication in percent rpm of the engine gas producer (compressor) by connection to a common synchronous generator, mounted on engine accessory drive section. The indicator and generator circuit requires 28 Vdc power from the essential bus.

**8-41. CLEANING — GAS PRODUCER TACHOMETERS.**

Clean gas producer tachometers in accordance with paragraph 8-3.

**8-42. INSPECTION — GAS PRODUCER TACHOMETERS.**

Inspect gas producer tachometers in accordance with paragraph 8-4.

**8-43. REMOVAL — GAS PRODUCER TACHOMETERS.**

Remove gas producer tachometers in accordance with paragraph 8-5.

**8-44. REPAIR — GAS PRODUCER TACHOMETERS.**

Repair gas producer tachometers in accordance with paragraph 8-6.

**8-45. FUNCTIONAL TEST — GAS PRODUCER TACHOMETERS — BENCH (AVIM).**

a. Disconnect plug from gas producer tachometer generator. Connect plug to MASTER GENERATOR output plug on test set (T67.1). Energize test stand and set controls according to instructions on the cover of test set.

b. Check that the gas producer tachometer indicator indicates within tolerance of various check points in following chart:

c. Disconnect plug from test set (T21) and reconnect it to gas producer tachometer generator. Check that connector is properly mated and secure.

TEST POINTS	INDICATOR	TOLERANCE
10%	5%	± 1.5%
20%	20%	± 1.5%
70%	70%	± 0.5%
100%	100%	± 0.5%

**8-46. INSTALLATION — GAS PRODUCER TACHOMETER.**

Install gas producer tachometer in accordance with paragraph 8-7.

**8-47. GAS PRODUCER TACHOMETER GENERATOR.**

**8-48. DESCRIPTION — GAS PRODUCER TACHOMETER GENERATOR.**

The gas producer tachometer generator, located on right side of engine on the accessory gearbox, monitors rpm of the gas producer turbine and transmits voltage signals to drive the gas producer tachometer indicators.

**P E** Refer to figure 8-1 for equipment location. **M** Refer to paragraph F-9 in Appendix F for equipment location chart.

**8-49. CLEANING — GAS PRODUCER TACHOMETER GENERATOR.**

Clean gas producer tachometer generator in accordance with paragraph 8-25.

**8-50. INSPECTION — GAS PRODUCER TACHOMETER GENERATOR.**

Inspect gas producer tachometer generator in accordance with paragraph 8-26.

**8-51. REMOVAL — GAS PRODUCER TACHOMETER GENERATOR.**

Remove gas producer tachometer generator in accordance with paragraph 8-27.

**8-52. REPAIR — GAS PRODUCER TACHOMETER GENERATOR.**

Repair gas producer tachometer generator in accordance with paragraph 8-28.

**8-53. FUNCTIONAL TEST - GAS PRODUCER TACHOMETER GENERATOR - BENCH (AVIM).**

Bench test gas producer tachometer generator in accordance with paragraph 8-29.

**8-54. INSTALLATION - GAS PRODUCER TACHOMETER GENERATOR.**

a. Install gas producer tachometer generator in accordance with paragraph 8-30.

b. Perform N1 system accuracy check in accordance with TM 55-4920-401-13& P.

**8-55. ENGINE OIL TEMPERATURE AND PRESSURE INDICATING SYSTEM.**

**8-56. DESCRIPTION - ENGINE OIL TEMPERATURE AND PRESSURE INDICATING SYSTEM.**

The engine oil temperature and pressure indicating system includes the pilot engine oil temperature and pressure indicator, engine oil pressure transducer, and engine oil temperature bulb. The system is powered from the 28 Vdc bus, and is protected by a 5 ampere TEMP IND ENG XMSN circuit breaker.

**8-57. TROUBLESHOOTING - ENGINE AND TRANSMISSION OIL TEMPERATURE AND PRESSURE INDICATING SYSTEM.**

a. **P E** Use table 8-2 and perform necessary checks to isolate trouble. Refer to figure 8-1 for equipment location and paragraph F-9 in Appendix F for wiring diagram. Broken or shorted wiring is always a probable cause of malfunction or failure and has not been included.

b. **M** Use table 8-2 and perform necessary checks to isolate trouble. Refer to paragraph F-9 in Appendix F for wiring diagram and equipment location chart. Broken or shorted wiring is always a probable cause of malfunction or failure and has not been included.

**NOTE**

**Before you use this table, be sure you have performed all operational checks. If you have a malfunction which is not listed in this table, notify the next higher level of maintenance.**

**Table 8-2. Troubleshooting Engine and Transmission Oil Temperature And Pressure Indicating System**

---

**CONDITION**

**TEST OR INSPECTION**

**CORRECTION ACTION**

1. Low pressure indication on indicator.

STEP 1. Check for kinked or obstructed pressure line.

**Replace or clean pressure line.**

2. Indicator has inaccurate or sticking pressure indication.

STEP 1. Check for defective indicator by substitution of a known good indicator.

**Replace indicator if defective (paragraph 8-1).**

**Table 8-2. Troubleshooting Engine and Transmission Oil Temperature  
And Pressure Indicating System (Cont)**

---

**CONDITION**

**TEST OR INSPECTION**

**CORRECTIVE ACTION**

3. Indicator has sluggish pressure indication.

STEP 1. Check for sludge in pressure line using procedures contained in paragraph 8-62, functional test.

**Bleed pressure line.**

4. Indicator has fluctuating pressure indication.

STEP 1. Check for loose electrical connection, or instrument clamped too tight.

**Check connections and/or readjust clamp.**

STEP 2. Incorrect restrictor installed in system.

**Install correct restrictor (0.018 to 0.020 inch opening).**

STEP 3. Check for blocked or clogged restrictor.

**Clean restrictor opening.**

5. Indicator has no pressure indication.

STEP 1. Check for defective transducer by substitution of known good transducer or perform functional test in accordance with paragraph 8-62.

**Replace transducer if defective (paragraph 8-67).**

STEP 2. Check for defective indicator by substitution of known good indicator or refer to paragraph 8-62 for functional test.

**Replace indicator if defective (paragraph 8-1).**

6. Oil temperature indication off scale at low end, or low reading - either constant or intermittent.

STEP 1. Check for defective indicator by substitution of known good indicator or refer to paragraph 8-62 for functional test.

**Replace indicator if defective (paragraph 8-1).**

STEP 2. Short circuit in leads from thermobulb to indicator.

**Make continuity check and repair or replace leads.**

Table 8-2. Troubleshooting Engine and Transmission Oil Temperature And Pressure Indicating System (Cont)

---

CONDITION

TEST OR INSPECTION

CORRECTIVE ACTION

7. Oil temperature indication off scale at high end, or high reading - either constant or intermittent.

STEP 1. Check for open circuit in thermobulb.

**Check continuity and repair wiring, or replace defective bulb.**

STEP 2. Check for defective indicator by substitution of known good indicator or perform functional test in accordance with paragraph 8-62.

**Check continuity and repair wiring, or replace defective bulb (paragraph 8-75).**

8. No indication of pressure or temperature on indicator.

STEP 1. Check for defective circuit breaker by use of multimeter or substitution of known good circuit breaker.

**Replace circuit breaker if defective (paragraph 9-23).**

STEP 2. Check for defective indicator by substitution of known good indicator or perform functional test in accordance with paragraph 8-62.

**Replace indicator if defective (paragraph 8-1).**

---

**8-58. ENGINE OIL TEMPERATURE AND PRESSURE INDICATOR.**

**8-59. DESCRIPTION - ENGINE OIL TEMPERATURE AND PRESSURE INDICATOR.**

The engine oil temperature and pressure indicator is located in the pilot instrument panel and indicates engine oil pressure in psi by means of the engine oil pressure transducer. It also indicates engine oil temperature in degrees celsius by means of an electrical resistance type thermobulb.

**8-60. CLEANING - ENGINE OIL TEMPERATURE AND PRESSURE INDICATOR.**

Clean engine oil temperature and pressure indicator in accordance with paragraph 8-3.

**8-61. INSPECTION - ENGINE OIL TEMPERATURE AND PRESSURE INDICATOR.**

Inspect engine oil temperature and pressure indicator in accordance with paragraph 8-4.

**8-62. FUNCTIONAL TEST - ENGINE OIL TEMPERATURE AND PRESSURE INDICATOR. (ON HELICOPTER).**

a. Perform functional test for oil pressure portion of indicator as follows:

(1) Disconnect pressure line from the engine oil pressure transducer.

(2) Connect variable pressure (0-150 psi) tester (T12) or equivalent to input line on engine oil pressure transducer.

(3) Close TEMP IND ENG XMSN circuit breaker.  
**P** Place BAT switch to ON. **F** **M** Place BATTERY switch to START.

(4) Apply pressure to transducer input port while monitoring engine oil pressure indicator.

(5) Various pressure and tolerances are listed in the following chart:

APPLIED PRESSURE	INDICATOR	INDICATOR TOLERANCE
100 PSI	100 PSI	± 3%
80 PSI	80 PSI	± 3%
60 PSI	60 PSI	± 3%
40 PSI	40 PSI	± 3%
20 PSI	20 PSI	± 3%

b. Perform functional test for oil temperature portion of indicator as follows:

(1) Close TEMP IND ENG XMSN circuit breaker.  
**P** Place BAT switch to ON. **F** **M** Place Battery switch to START.

(2) Check that temperature indicators indicate approximately ambient temperature.

### 8-63. FUNCTIONAL TEST – ENGINE OIL TEMPERATURE AND PRESSURE INDICATOR – BENCH (AVIM).

Bench test for the temperature portion is as follows:

a. Disconnect electrical plug in back of oil temperature indicator. Remove indicator from instrument panel. Connect indicator to electric thermometer tester (T78), or equivalent, using the appropriate adapter cable provided with the tester.



Always ensure that the indicator is connected before turning switch (7) to the "24" volt position.

b. Check zero setting of voltmeter (1) and adjust if necessary. Turn switch (7) to the "24" volt position.

c. Adjust pointer of voltmeter (1) to coincide with red line of 28.50 volts by operating rheostat (5). Position switch (8) to the left and single position.

d. Set temperature selector switch (2) to temperature points on the "left inner scale" (90.38 ohms at zero degrees celsius temperature).

e. Rotate switch (2) to required test points. Tap indicator before taking a reading. The test points and tolerances are listed in following chart:

TEST POINTS	INDICATOR READING	INDICATOR TOLERANCE
-50	-50°C	± 4°C
-25	-25°C	± 4°C
0	0°C	± 4°C
+25	+25°C	± 4°C
+50	+50°C	± 4°C
+100	+100°C	± 4°C
+150	+150°C	± 4°C

f. Turn switch (7) to the "OFF" position and disconnect indicator from tester. Install indicator in instrument panel and check for security.

### 8-64. REMOVAL – ENGINE OIL TEMPERATURE AND PRESSURE INDICATOR.

Remove engine oil temperature and pressure indicator in accordance with paragraph 8-5.

### 8-65. REPAIR – ENGINE OIL TEMPERATURE AND PRESSURE INDICATOR.

Repair engine oil temperature and pressure indicator in accordance with paragraph 8-6.

### 8-66. INSTALLATION – ENGINE OIL TEMPERATURE AND PRESSURE INDICATOR.

Install engine oil temperature and pressure indicator in accordance with paragraph 8-7.

### 8-67. ENGINE OIL PRESSURE TRANSDUCER.

### 8-68. DESCRIPTION – ENGINE OIL PRESSURE TRANSDUCER.

The engine oil pressure transducer located on top of engine inlet section, monitors engine oil pressure and transmits voltage signals to engine oil pressure

indicator. **P E** Refer to figure 8-1 for equipment location. **M** Refer to paragraph F-9 in Appendix F for equipment location chart.

**8-69. CLEANING — ENGINE OIL PRESSURE TRANSDUCER.**

- a. Remove moisture and loose dirt with a dean, soft cloth.



Cleaning advent is flammable and toxic Provide adequate ventialtion. Avoid pro longed breathing of advent vapors and contact with skin or eyes.

- b. Remove oil, grease, fungus, and ground-in dirt with a dean, lint-free cloth dampened with dry cleaning solvent (C112).
- c. Remove dirt from electrical connectors with a bristle brush.

**8-70. INSPECTION — ENGINE OIL PRESSURE TRANSDUCER.**

- a. Inspect pressure transducer for crack, secure and proper mounting, and proper operation.
- b. Inspect oil tine and fitting connection for leaks and proper installation.

Inspect electrical connector for damaged or bent pin and cracked inserts.

**8-71. FUNCTIONAL TEST — ENGINE OIL PRESSURE TRANSDUCER.**

The pressure transducer is functionally tested during testing of the indicator using variable pressure tester (paragraph 8-62). The following electrical resistance check may be conducted on pressure transducer independently from indicator.

- a. Using multimeter (T2), or equivalent, check resistance between contacts of electrical receptacle on top of transducer.
- b. Resistance readings across the four-pin connector should be as follows:

Pin A to Pin B	875 to 2400 ohms
Pin A to Pin C	875 to 2400 ohms
Pin A to Pin D	1250 to 3050 ohms
Pin B to Pin C	300 to 1000 ohms
Pin B to Pin D	525 to 1400 ohms
Pin C to Pin D	525 to 1500 ohms

**8-72. REMOVAL – ENGINE OIL PRESSURE TRANSDUCER.**

- a. Open engine cowling.
- b. Disconnect electrical connector. Disconnect oil line.
- c. Cap openings of oil line and protect electrical connector with cap or tape.
- d Remove lockwire mounting nut and packing. Remove transducer from helicopter.

**8-73. REPAIR – ENGINE OIL PRESSURE TRANSDUCER.**

- a. Repair damaged electrical connectors.
- b. Tighten loose oil line or fitting connection.
- c. Replace defective or damaged oil tine or fitting.
- d. Replace pressure transducer if cracked or damaged.
- e. Reinstall improperly mounted pressure transducer.

**8-74. INSTALLATION — ENGINE OIL PRESSURE TRANSDUCER.**

- a. Position transducer on bracket. Install damp and grommet.
- b. Remove protective covers and connect the oil line to transducer. Install electrical connectors.
- c. Install cowling.

**8-75. ENGINE OIL TEMPERATURE BULB.**

**8-76. DESCRIPTION – ENGINE OIL TEMPERATURE BULB.**

The engine oil temperature bulb, installed in the engine oil pump housing is a resistance type thermobulb which monitors engine oil temperature and transmits varying voltage signals to engine oil temperautre of indicator. **P E** Refer to figure 8-1 for equipment locations. **M** Refer to paragraph F-9 in Appendix F for equipment locations chart.



**8-77. CLEANING - ENGINE OIL TEMPERATURE BULB.**

a. Remove moisture and loose dirt with a clean, soft cloth.



Cleaning solvent is flammable and toxic. Provide adequate ventilation. Avoid prolonged breathing of solvent vapors and contact with skin or eyes.

b. Remove oil, grease, fungus and ground-in dirt with a clean, lint-free cloth dampened with dry cleaning solvent (C112).

c. Remove dirt from electrical connectors with a bristle brush.

**8-78. INSPECTION, - ENGINE OIL TEMPERATURE BULB.**

a. Inspect temperature bulb for cracks, leaks, security and proper mounting.

b. Inspect electrical connector for damaged or bent pins and cracked inserts.

**8-79. REMOVAL - ENGINE OIL TEMPERATURE BULB.**

a. Cut lockwire and disconnect electrical connector.

b. Remove lockwire and unscrew temperature bulb from oil manifold.

c. Remove gasket.

**8-80. REPAIR - ENGINE OIL TEMPERATURE BULB.**

a. Repair damaged electrical connectors.

b. Replace damaged or worn gasket.

c. Replace temperature bulb if cracked or damaged.

**8-81. FUNCTIONAL TEST - ENGINE OIL TEMPERATURE BULB - BENCH (AVIM).**

a. Perform resistance check as follows:

(1) Remove oil temperature bulb to be checked and allow sufficient time to adjust to ambient temperature.

(2) With resistance bridge (T62) or (T63) measure resistance of temperature bulb between pin A and B. Ambient temperature test points and tolerances are listed in following chart:

AMBIENT TEMPERATURE TEST POINT DEGREES	RESISTANCE (OHMS)	TOLERANCE (OHMS)
-20° Celsius (-4°F)	83.77	±0.4
-10° Celsius (14°F)	87.04	±0.4
0° Celsius (32°F)	90.38	±0.4
+10° Celsius (50°F)	93.80	±0.4
+20° Celsius (68° F)	97.80	±0.4
+30° Celsius (86° F)	100.91	±0.4
+40° Celsius (104°F)	104.60	±0.4

b. Perform insulation leakage test. With temperature bulb subjected to a 100 volt potential between any electrical pin and bulb housing, the minimum resistance shall be 5 megohms.

c. Reinstall temperature bulb.

**8-82. INSTALLATION - ENGINE OIL TEMPERATURE BULB.**

a. Coat threads and gasket with lubricating oil (79 or 80) when installing gasket on temperature bulb.

b. Install temperature bulb and gasket in manifold.

c. Lockwire (137) to adjacent bolt head on manifold.

d. Connect and lockwire (C137) electrical connector.

**8-83. TURBINE GAS TEMPERATURE INDICATING SYSTEM.**

**8-84. DESCRIPTION - TURBINE GAS TEMPERATURE INDICATING SYSTEM.**

The turbine gas temperature (TGT) indicating system includes pilot and gunner turbine gas temperature indicators and turbine temperature thermocouple. The system requires 28 Vdc power, which is provided

by the essential dc bus through TGT IND circuit breaker (1CB17).

### 8-85. TESTING - TURBINE GAS TEMPERATURE INDICATING SYSTEM.

**NOTE**

**Anytime any component of the turbine gas temperature indicating system is replaced perform a system calibration test.**

a. Disconnect plug 1P5 from receptacle 1J5. Connect resistance bridge (T62 or T63) to pins A and B of 1P5 and measure resistance of the thermocouple loop in engine. Check that resistance of thermocouple loop is within 1.225 thru 1.8 ohms for the engine.

b. Remove resistance bridge leads and reconnect plug 1P5 to 1J5. Check that connector is properly mated, tight and secure.

c. Disconnect plug 1M1P1 from pilot turbine gas temperature indicator. Disconnect plug 1M11P1 from gunner turbine gas temperature indicator. Connect resistance bridge (T62 or T63) to pins T and U of plug 1M1P1. Check that total turbine gas temperature circuit resistance is 5 TO 100 ohms at normal room temperature.

d. Remove resistance bridge from pins T and U of plug 1M1P1 and connect it to pins T and U of plug 1M11P1. Repeat circuit resistance check of previous step c.

e. Remove resistance bridge and reconnect the plugs to each indicator. Check that connectors are properly mated and secure.

### 8-86. TROUBLESHOOTING - TURBINE GAS TEMPERATURE INDICATING SYSTEM.

a. **PE** Use table 8-3 and perform necessary checks to isolate trouble. Refer to figure 8-1 for equipment location and paragraph F-9 in Appendix F for wiring diagram. Broken or shorted wiring is always a probable cause of malfunction or failure and has not been included.

b. **M** Use table 8-3 and perform necessary checks to isolate trouble. Refer to paragraph F-9 in Appendix F for wiring diagram and equipment location chart. Broken or shorted wiring is always a probable cause of malfunction or failure and has not been included.

**NOTE**

**Before you use this table, be sure you have performed all normal operational checks. If you have a malfunction which is not listed in this table, notify the next higher level of maintenance.**

**Table 8-3. Troubleshooting Turbine Gas Temperature Indicating System**

---

**CONDITION**

**TEST OR INSPECTION**

**CORRECTIVE ACTION**

1. Indicator fails to respond.

STEP 1. Determine if indicator is defective by substitution of known good indicator or perform functional test in accordance with paragraph 8-91.

**Replace indicator if defective (paragraph 8-1).**

STEP 2. Check for open thermocouple lead or defective thermocouple in accordance with TM 55-2840-229-23.

**Replace thermocouple if defective.**

Table 8-3. Troubleshooting Turbine Gas Temperature Indicating System (Cont)

---

**CONDITION**

**TEST OR INSPECTION**

**CORRECTIVE ACTION**

STEP 3. Determine if TGT IND circuit breaker is defective by use of multimeter or substitution of known good circuit breaker.

**Replace circuit breaker if defective (paragraph 9-23).**

2. Indicator operates erratic or incorrectly.

STEP 1. Check for defective thermocouple leads in accordance with paragraph 8-85.

**Replace defective leads and retest system.**

STEP 2. Check for defective indicator by substitution of known good indicator.

**Replace indicator** if defective (paragraph 8-1).

STEP 3. Check for defective exhaust thermocouple in accordance with TM 55-2840-229-23.

Replace thermocouple and retest system (paragraph 8-85).

---

**8-87. TURBINE GAS TEMPERATURE INDICATORS.**

**8-88. DESCRIPTION - TURBINE GAS TEMPERATURE INDICATORS.**

The pilot and gunner turbine gas temperature indicators, located on respective instrument panel, indicate turbine gas temperature in degrees celsius. The indicators operate on electrical potential from the thermocouple harness assembly, mounted on first stage power turbine nozzle of combustor turbine assembly.

**8-89. CLEANING - TURBINE GAS TEMPERATURE INDICATORS.**

Clean turbine gas temperature indicators in accordance with paragraph 8-3.

**8-90. INSPECTION - TURBINE GAS TEMPERATURE INDICATORS.**

Inspect turbine gas temperature **indicators** in accordance with paragraph 8-4.

### 8-91. FUNCTIONAL TEST - TURBINE GAS TEMPERATURE INDICATORS.

#### NOTE

Refer to TM 55-2840-229-23 for thermocouple harness assembly resistance check.

#### NOTE

The following notification must be implemented when a Penn Airborne Turbine Gas Temperature Indicator, P/N 209-075-651-3 and PIN 9A1290, is tested on a Howell Instruments Tester Exhaust Gas Temperature, P/N BH112JB53, with a Temperature Indicator Adapter, P/N BH16492: Ground the negative simulated thermocouple lead, Pin "U" in the BH16492 adapter, to a suitable ground.

a. Remove plug 1M1P1 from back of pilot turbine gas temperature indicator. Remove plug 1M11P1 from back of gunner turbine gas temperature indicator. Check each indicator for proper operation and accuracy using test set (T68) and observing appropriate tester operating instruction. Indicators should read within +10°C of correct temperature at 810°C and 866°C.

b. Remove test set (T68) and reconnect plugs 1M1P1 and 1M11P1 to pilot and gunner turbine gas temperature indicators, respectively. Check that connectors are properly mated and secure.

### 8-92. REMOVAL - TURBINE GAS TEMPERATURE INDICATORS.

Remove turbine gas temperature indicators in accordance with paragraph 8-5.

### 8-93. REPAIR - TURBINE GAS TEMPERATURE INDICATORS.

Repair turbine gas temperature indicators in accordance with paragraph 8-6.

### 8-94. INSTALLATION - TURBINE GAS TEMPERATURE INDICATORS.

Install turbine gas temperature indicators in accordance with paragraph 8-7.

### 8-95. TORQUE PRESSURE INDICATING SYSTEM.

### 8-96. DESCRIPTION - TORQUE PRESSURE INDICATING SYSTEM.

The torque pressure indicating system includes the pilot and gunner torque pressure indicators and respective torque pressure transducers. The torque pressure indicators indicate engine output torque pressure in percent torque by means of respective torque pressure transducers. The system is powered by 28 Vdc essential bus and is protected by a 5 ampere TRQ IND circuit breaker. Regulated 10Vdc is furnished by the indicator to the transducer.

### 8-97. TROUBLESHOOTING - TORQUE PRESSURE INDICATING SYSTEM.

a. **P E** Use table 8-4 and perform necessary checks to isolate trouble. Refer to figure 8-1 for equipment location and paragraph F-9 in Appendix F for wiring diagram. Broken or shorted wiring is always a probable cause of malfunction or failure and has not been included.

b. **M** Use table 8-4 and perform necessary checks to isolate trouble. Refer to paragraph F-9 in Appendix F for wiring diagram and equipment location chart. Broken or shorted wiring is always a probable cause of malfunction or failure and has not been included.

**NOTE**

**Before you use this table, be sure you have performed all normal operational checks. If you have a malfunction which is not listed in this table, notify the next higher level of maintenance.**

**Table 8-4. Troubleshooting Torque Pressure Indicating System**

---

**CONDITION****TEST OR INSPECTION****CORRECTIVE ACTION**

1. Either indicator has inaccurate or sticking pressure indication.

STEP 1. Check for defective indicator by substitution of known good indicator.

**Replace indicator if defective (paragraph 8-1).**

2. Indicator has sluggish pressure indication.

STEP 1. Check for sludge in pressure line in accordance with paragraph 8-102.

**Bleed pressure line.**



Table 8-4. Troubleshooting Torque Pressure Indicating System (cont)

**CONDITION**

**TEST OR INSPECTION**

**CORRECTIVE ACTION**

3. Both indicators have no or low reading.
  - STEP 1. Check for kinked or obstructed pressure line.  
Replace or dean line.
  - STEP 2. Determine if transducers are defective by substitution of known good transducer or perform functional test in accordance with paragraph 8-102.  
Replace transducer if defective (paragraph 8-106).
  - STEP 3. Check for open circuit between transducer end indicator.  
Make continuity check and replace or repair leads.
  - STEP 4. Check for defective pressure metering valve.  
Replace metering valve in accordance with TM 55-2840-229-24.
4. Indicator has fluctuating pressure indication.
  - STEP 1. Check for loose electrical connections, or instrument damped too tight  
Check connections and/or re-adjust damp.
  - STEP 2. Determine if incorrect restrictor is installed in system.  
Install correct restrictor Incorrect (0.025 to 0.027 hole opening).
5. Indicator has high reading.
  - STEP 1. Check main rotor blade for excess paint since the extra drag can increase engine torque.  
Remove excess paint and repaint.

**8-98. TORQUE PRESSURE INDICATORS.**

**8-99. DESCRIPTION – TORQUE PRES-SURE INDICATORS.**

The pilot and gunner torque pressure indicators, mounted in respective instrument panel, indicate engine output shaft torque pressure in percent torque by means of the respective torque pressure transducer.

**8-100. CLEANING – TORQUE PRESSURE INDICATORS.**

Clean torque pressure indicators in accordance with paragraph 8-3.

**8-101. INSPECTION — TORQUE PRESSURE INDICATORS.**

Inspect torque pressure indicators in accordance with paragraph 8-4.

**8-102. FUNCTIONAL TEST – TORQUE PRESSURE INDICATORS.**

- a. Close TRQ IND circuit breaker.
- b. Disconnect the pressure line from the engine at the bulkhead tee fitting.
- c. Connect a pressure line from the tester, pressure gage (MP-1) to the bulkhead tee fitting. Slowly apply pressure to the transducers until 56 psig is indicated on the master gage (MP-1).
- d. Record the percent readings on both the gunner and pilot indicators. The indicators must read 100 plus or minus 2 percent.

**NOTE**

If one of the readings is fairly close to the acceptable 98 to 102 percent range, reverse the electrical cannon plug leads from one transducer to the other and repeat the pressure test. This switching utilizes the differences between the sensitivities of each electrical system and could make use of otherwise unserviceable equipment.

- e. By part substitution, replace the faulty pressure transducer or indicator.
- f. Open TRQ IND circuit breaker and reconnect the torque pressure lines.

**8-103. REMOVAL – TORQUE PRESSURE INDICATORS.**

Remove torque pressure indicators in accordance with paragraph 8-5.

**8-104. REPAIR – TORQUE PRESSURE INDICATORS.**

Repair torque pressure indicators in accordance with paragraph 8-6.

**8-105. INSTALLATION – TORQUE PRESSURE INDICATORS.**

Install torque pressure indicators in accordance with paragraph 8-7.

**8-106. TORQUE PRESSURE TRANSDUCER.**

**8-107. DESCRIPTION – TORQUE PRESSURE TRANSDUCER.**

The pilot and gunner torque pressure transducer, mounted on a bracket in transmission compartment, monitors engine output shaft torque and transmits varying voltage signals to the respective torque pressure indicator. **P E** Refer to figure 8-1 for equipment location. **M** Refer to paragraph F-9 in Appendix F for equipment location chart.

**8-108. CLEANING – TORQUE PRESSURE TRANSDUCER.**

- a. Remove moisture and loose dirt with a clean, soft cloth.

**WARNING**

Cleaning solvent is flammable and toxic, Provide adequate ventilation. Avoid prolonged breathing of solvent vapors and contact with skin or eyes.

- b. Remove oil, grease, fungus, and ground-in dirt with a clean lint-free cloth dampened with dry cleaning solvent (C112).

- c. Remove dirt from electrical connectors with a bristle brush.

**8-109. INSPECTION – TORQUE PRESSURE TRANSDUCER.**

- a. Inspect pressure transducer for cracks, secure and proper mounting, and proper operation.

- b. Inspect oil line and fitting connection for leaks and proper installation.

- c. Inspect electrical connector for damaged or bent pins and cracked inserts.

**8-110. FUNCTIONAL TEST – TORQUE PRESSURE TRANSDUCER.**

Test torque pressure transducer in accordance with paragraph 8-102.

**8-111. REMOVAL – TORQUE PRESSURE TRANSDUCER.**

- a. Remove cowling from transmission.



**b.** Disconnect electrical connector, hose, and oil line from transducer to be removed.

**c.** Cap openings of oil line and protect electrical connector with electrical tape (C121).

**d.** Remove nut and washer. Remove transducer from helicopter.

### **8-112. REPAIR - TORQUE PRESSURE TRANSDUCER.**

**a.** Repair damaged electrical connectors.

**b.** Tighten loose oil line or fitting connection.



- c. Replace defective or damaged oil line or fitting.
- d. Replace pressure transducer if cracked or damaged.
- e. Reinstall improperly mounted pressure transducer.

### 8-113. INSTALLATION - TORQUE PRESSURE TRANSDUCER.

- a. Position transducer in bracket and install with washer and nut.
- b. Remove protective covers and connect oil line, hose and electrical connector to transducer. Install cowling.

## SECTION III. FLIGHT INSTRUMENTS

### 8-114. FLIGHT INSTRUMENTS.

#### 8-115. DESCRIPTION - FLIGHT INSTRUMENTS.

Flight instruments include the pitot-static system, airspeed indicators, altimeters, attitude indicating system, and vertical speed indicator.

#### 8-116. PITOT - STATIC SYSTEM.

#### 8-117. DESCRIPTION - PITOT-STATIC SYSTEM.

The pitot-static system (figure 8-2) consists of the electrically heated pitot tube, two static ports, pitot and static drains, and pitot and static lines necessary to connect to airspeed indicators, altimeters, vertical speed indicator, and air data pressure transducer. (The air data pressure transducer is a component of the turret system, refer to **P** TM 9-1090-203 or **E M** TM 9-1090-206 series maintenance manuals.) The pitot tube is mounted on upper left side of forward pylon fairing. The static ports are located one on each side of pitot section, in line with instrument panel. Information pertaining to pitot heater electrical system is contained in paragraph 9-384.

#### **CAUTION**

**Do not apply suction to pitot lines or pressure to static lines except as instructed in paragraph 8-117.1.**

#### **NOTE**

**Assure pitot static tester has a current calibration label (DA Form 80). Use appropriate power supply in accordance with pitot static tester requirements.**

#### **NOTE**

**Except for the use of system drain, a functional check of the pitot-static system and pitot-static instruments will be performed following any opening and closing of the pitot-static system.**

#### 8-117.1. FUNCTIONAL CHECK - PITOT STATIC SYSTEM.

##### a. Pitot Line Leak Check.

(1) Seal pitot tube drain holes air tight with pressure sensitive tape (C123).

(2) Hook up airspeed outlet of pitot-static tester to pitot system in accordance with figure 8-2.1. Open vacuum and up and down valves, close pressure up and down valves. Rotate airspeed selector valve to open. Valve is located on top of test set. Rotate pressure selector valve to airspeed indicator position. Apply power to the test set.

(3) Slowly apply pressure to pitot line until the airspeed indicator reads 120 knots.

(4) Tap instrument to remove friction effects. When indicator pointer drops more than 10 mph (8.7 knots) in one minute, a leak is indicated. Slowly decrease pressure to return tester airspeed indicator to zero, repair any faults if necessary and repeat step above.

##### b. Airspeed Indicator Functional Check.

(1) Slowly apply pressure to pitot line to obtain airspeed readings in table 8-4.1. Indicator should be gently tapped prior to reading. Check need not exceed 120 knots.

**Table 8-4.1. TOLERANCE (± KNOTS)**

Airspeed Check Points (Knots)	MS28045 10 to 150 Knots	MS28021 20 to 250 Knots	MS28046 40 to 400 Knots
40	3	5	4
60	3	3	3
80	3	3	3
100	3	4	3
120	3	4	3
140	3	5	4
160		5	4

(2) If readings are not within tolerance of table 8-4.1, slowly relieve pressure on pitot line until airspeed indicator reads zero. Replace indicator with serviceable one and repeat steps b(1) and (2) above.

(3) Airspeed indicators that fail test shall be turned in for overhaul.

(4) Bleed pitot-static tester pressure system.

**c. Static Line Leak Check.**

(1) Hook up pitot-static tester, rate of climb and altimeter outlet, to pitot and static system in accordance with figure 8-2.2

**CAUTION**

**Make sure that both aircraft pitot and static lines are connected to airspeed indicator to prevent possible damage to airspeed indicator.**

**NOTE**

**Hooking up the pitot line to the tester vacuum source will only be done during the following check to equalize the pressure in the airspeed indicator case to prevent damage to its diaphragm.**

(2) Tape all unused static ports.

(3) Adjust test set and aircraft altimeter barometric scales to read 29.92. Gently tap test set altimeter, and check to insure that aircraft altimeters read within 70 feet of test set altimeter and report of calibration data card located across the top of tester outlet valve cover.

(4) If aircraft altimeters fail to meet this check, remove and install a serviceable instrument and repeat step c(3) above.

(5) Open pitot pressure up and down valves. Close vacuum up and down valves. Close airspeed valve at top of test set. Rotate vacuum selector valve to altimeter position. Apply power to test set. Slowly apply vacuum to pitot and static lines (figure 8-2.2) until the altimeter reads 1000 feet above reading obtained from step c(3). Close vacuum source and gently tap altimeter at same time until rate of climb indicator stabilizes at zero. After stabilization, the altimeter should not drop more than 100 feet in one minute. Slowly decrease vacuum until rate of climb stabilizes at zero. Repair any faults if necessary and repeat this step.

**d. Vertical Speed Indicator Functional Check.**

(1) Slowly apply vacuum to aircraft system to obtain rate of climb readings in table 8-4.2. After vertical speed indicator stabilizes at desired reading, instrument shall be subjected to gentle tapping, and readings compared to report of calibration data card across the top of tester. After completion of checks, close both pitot static tester vacuum valves.

**Table 8-4.2. Vertical Speed Tolerance Feet Scale Accuracy**

Standard Altitude Check Interval (Feet)	Check Rate Ascent or Descent (fpm)	Tolerance Scale Error (fpm)
2000 to 2500	500	±100
2000 to 3000	1000	±200
2000 to 4000	2000	±300
2000 to 5000	3000	±300
15,000 to 17,000	2000	±300

(2) Slowly decrease vacuum until desired rate of descent is obtained from table 8-4.2. After vertical speed indicator stabilizes at desired readings, subject instrument to gentle tapping and compare readings to tester rate of climb indicator and calibration data card.

(3) Instruments that fail check and tolerances shall be replaced with a serviceable unit and steps d(1) and (2) above repeated.

(4) Vertical speed indicators that fail check will be turned in for overhaul.

**e. Altimeter Functional Check.**

(1) Apply 28 volt power to aircraft electrical system to provide electrical power for counter drum altimeter vibrators.

(2) Slowly apply vacuum to aircraft system at a rate not to exceed 3000 feet per minute. Continue to apply vacuum until altimeter readings reach the next higher reading on table 8-4.3 above altimeter altitude indicated when barometric scale is set at 29.92.

**Table 8-4.3. Altimeter Scale Error**

Altitude (feet)	Tolerance (± feet)
0	70
500	70
1,000	70
2,000	70
3,000	70
5,000	100
10,000	130
15,000	140

(3) Close vacuum valve and keep altimeter at this setting for at least one minute, but not more than five minutes, then gently tap three-pointer type altimeters before reading. Assure that vibrators are operative on counter drum altimeters before readings are compared to tolerance shown in table 8-4.3.

(4) Compare the readings of the installed instruments against readings on the tester and calibration data card at the check points shown in table 8-4.3.

**NOTE**

**Altimeters that do not pass the performance requirements of table 8-4.3 shall be removed from aircraft and shop tested in accordance with the test procedures in TM 55-1500-204-23 (Series) to verify malfunctions. Install serviceable altimeter and repeat steps (3) and (4).**

(5) Remove pitot static tester and all tape from pitot/static lines and openings. Check hoses for adequate clearance after removal of the tape from the static ports.

**8-118. TROUBLESHOOTING - PITOT-STATIC SYSTEM.**

Refer to applicable portions of airspeed indicators, altimeters, and vertical speed indicator troubleshooting procedures.

**8-119. PITOT-STATIC PIPING AND FITTINGS.**

**8-120. DESCRIPTION - PITOT-STATIC PIPING AND FITTINGS.**

The pitot-static piping and fittings consist of flexible piping lines routed from the pitot tube and static ports to airspeed indicators, altimeters, vertical speed indicator, and air data pressure transducer. The piping lines are connected with nylon fittings and contain a pitot drain and static drain (figure 8-2).

**8-121. CLEANING - PITOT-STATIC PIPING AND FITTINGS.**

**NOTE**

**The air data pressure transducer is located above and aft of left ammunition bay door, and is connected to pitot-static system.**

a. Disconnect pitot and static lines from airspeed indicators and air data pressure transducer. Disconnect static lines from altimeters and vertical velocity indicator. Cap openings in indicators and pressure transducer to prevent entrance of foreign material.

b. Remove caps and open pitot drain valve and static drain valve.

**CAUTION**

**Disconnect air data pressure transducer and all instruments that use pitot or static air pressure before blowing lines clear.**

c. Blow all lines clean with filtered, compressed air.

d. Uncap openings in indicators and transducer and reconnect all lines.

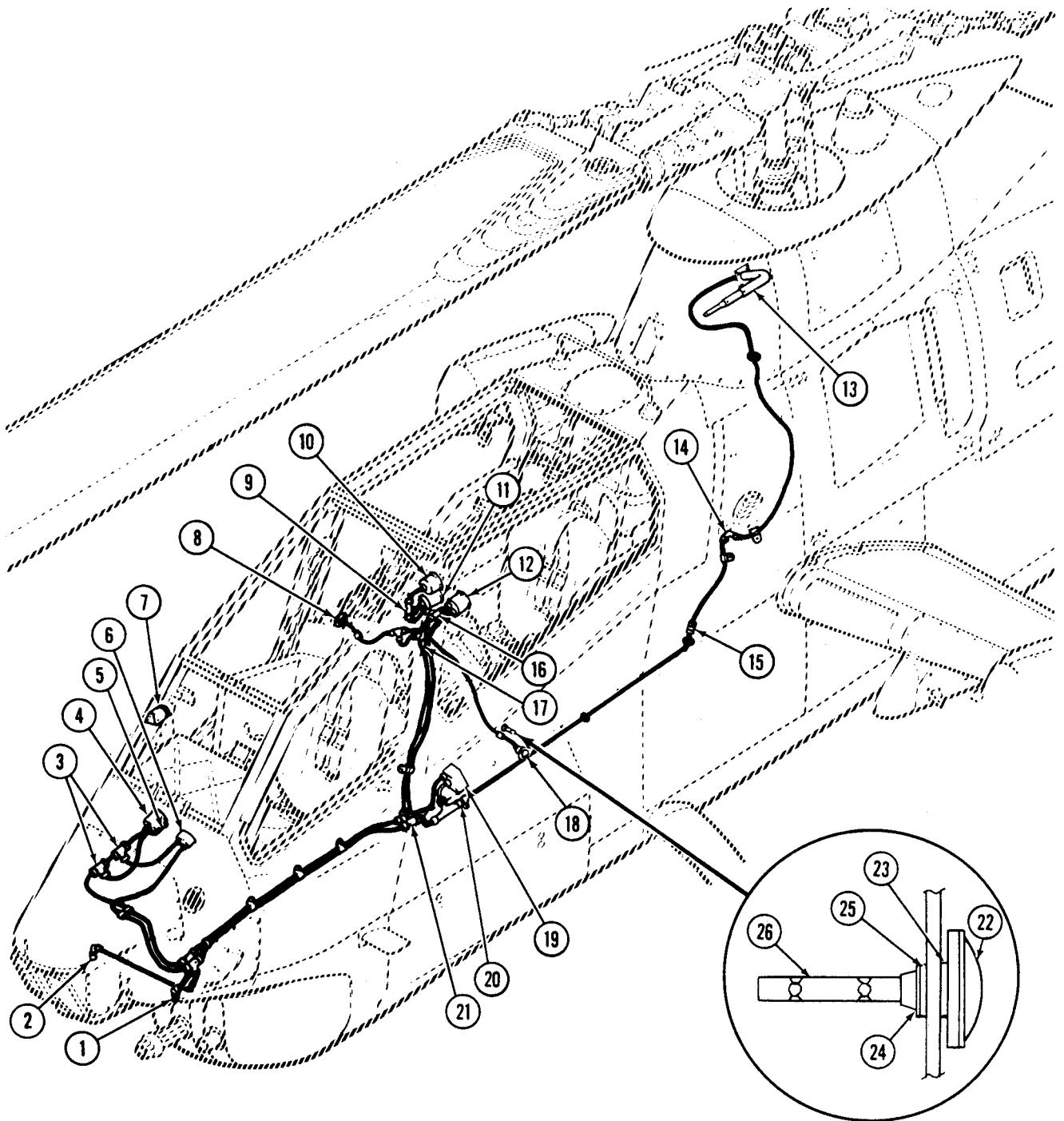

- |                                       |                                       |                                    |
|---------------------------------------|---------------------------------------|------------------------------------|
| 1. Static drain                       | 10. Altimeter (pilots)                | 19. Air data pressure transducer   |
| 2. Pitot drain                        | 11. Vertical speed indicator (pilots) | 20. Restrictor — tee (pitot drain) |
| 3. Union tee                          | 12. Airspeed indicator (pilots)       | 21. Pipe tee                       |
| 4. Altimeter (gunners)                | 13. Pitot tube                        | 22. Free air temperature gage case |
| 5. Vertical speed indicator (gunners) | 14. Pipe elbow                        | 23. Case washer                    |
| 6. Airspeed indicator (gunners)       | 15. Pipe union                        | 24. Dished washer                  |
| 7. Standby compass                    | 16. Pipe tee                          | 25. Grommet                        |
| 8. Static port                        | 17. Pipe tee                          | 26. Sunshield                      |
| 9. Pipe tee                           | 18. Static port                       |                                    |

209075-317D

Figure 8-2. Pitot-Static System (Typical)

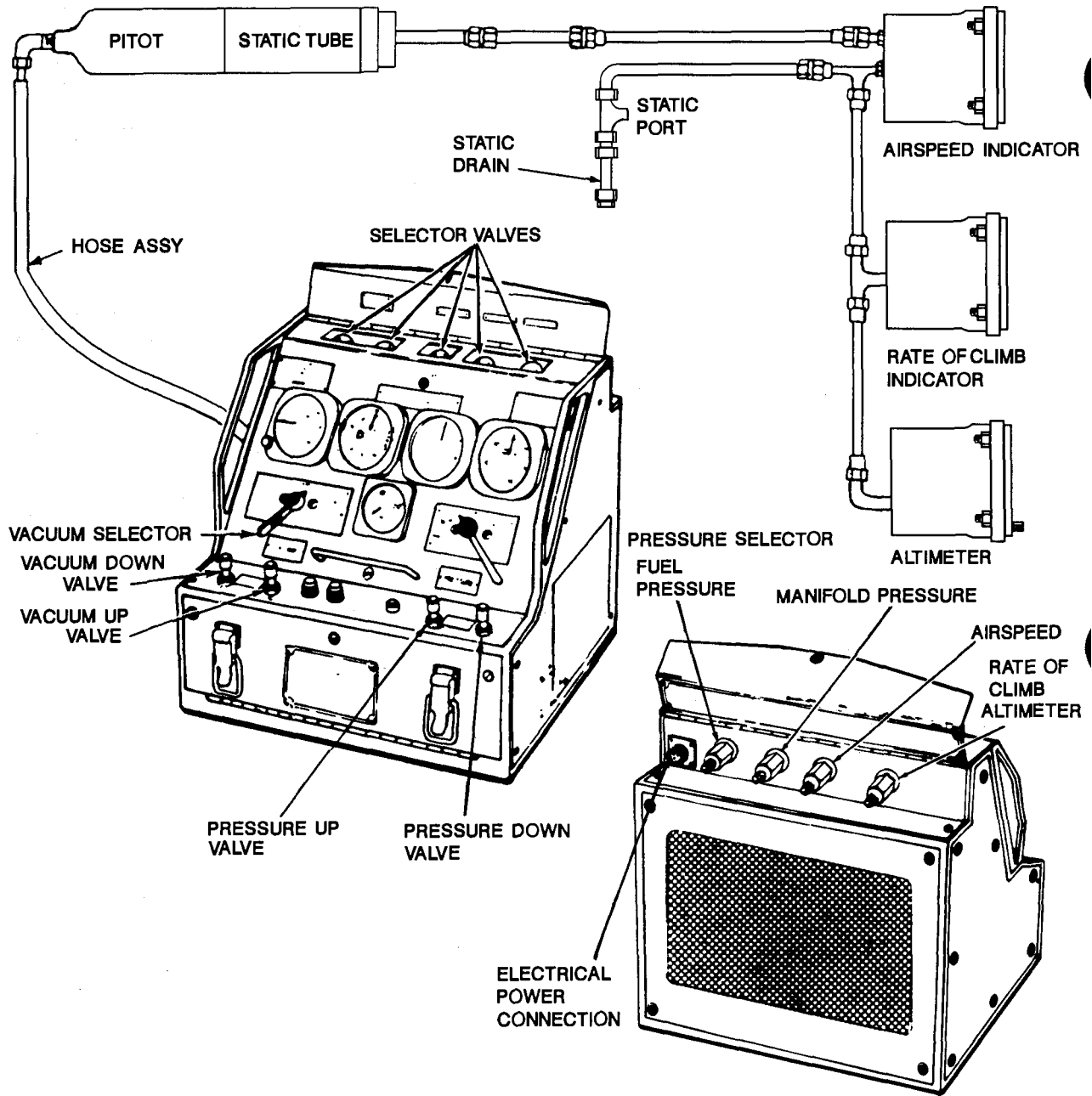

Figure 8-2-1. Connection for Pitot Leak Check (Typical)



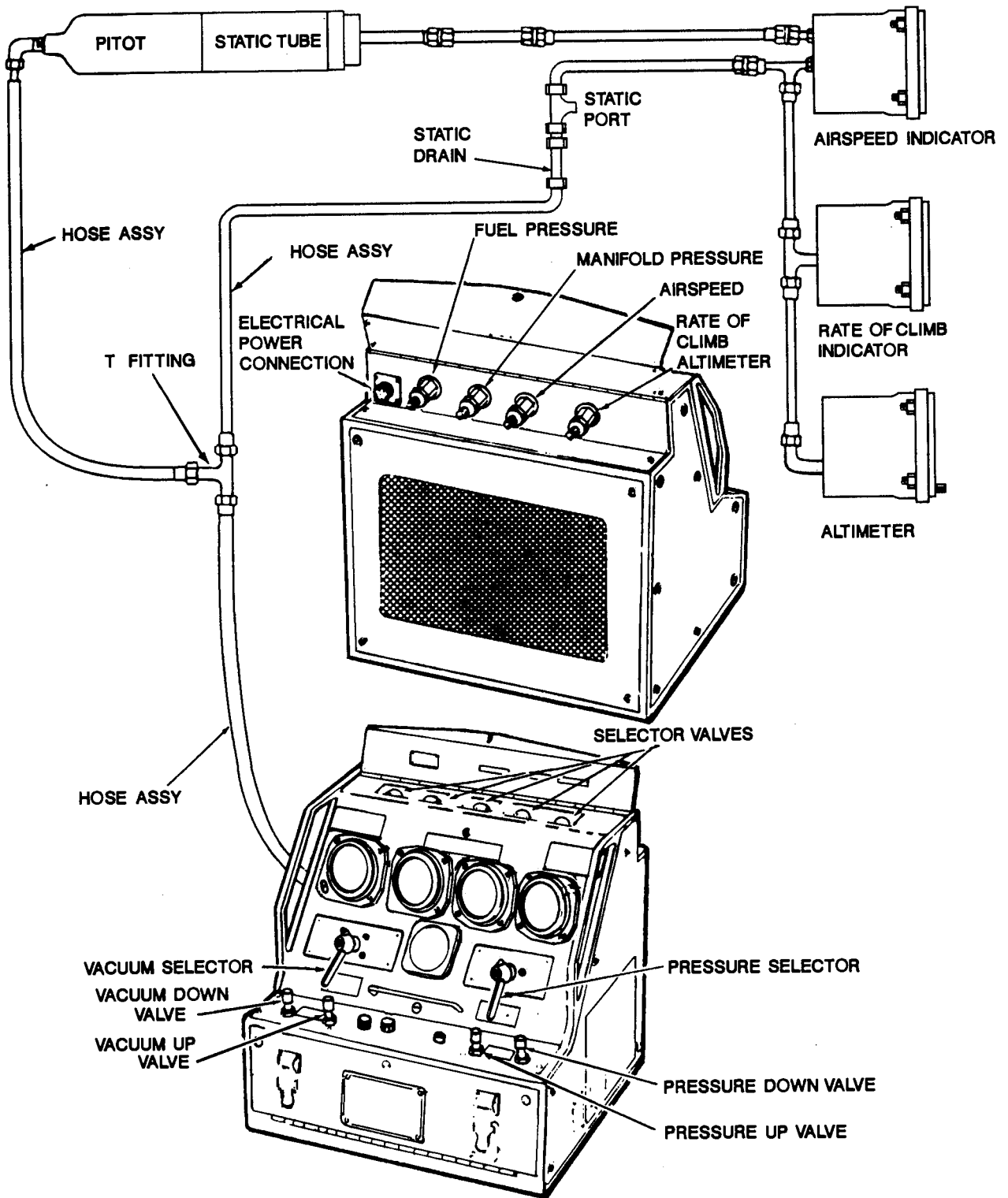

Figure 8-2-2. Connections for Static Leak Check (Typical)



e. Assemble nylon fittings as follows:

(1) Install coupling nut on nylon tubing.

(2) Install insert into end of nylon tubing.

(3) Apply silicone compound (C110) to threads of nylon nut and fitting.

(4) Connect coupling nut to fitting and torque nut fingertight.

f. Close pitot and static drain valves and install drain caps.

**8-122. INSPECTION - PITOT-STATIC PIPING AND FITTINGS.**

a. Inspect pitot and static piping and fittings for leaks, chafing, crimping, or other visible damage.

b. Inspect system for improperly installed fittings and clamps.

**8-123. FUNCTIONAL CHECK - PITOT-STATIC PIPING AND FITTINGS.**

Perform functional test in accordance with paragraph 8-117.1.

**8-124. TROUBLESHOOTING - PITOT-STATIC PIPING AND FITTINGS.**

Refer to applicable portions of airspeed indicator, altimeters, and vertical speed indicator troubleshooting procedures. (See figure 8-2.)

**8-125. REMOVAL - PITOT-STATIC PIPING AND FITTINGS.**

a. Disconnect pitot and static lines from indicators and air data pressure transducer. Cap openings in indicators and pressure transducer to prevent entrance of foreign material.

b. Disconnect applicable nylon fittings and clamps.

c. Remove pitot and static lines.

**8-126. REPAIR - PITOT-STATIC PIPING AND FITTINGS.**

a. Replace defective or damaged pitot and static lines.

b. Tighten or properly install fittings and clamps.

c. Replace defective or damaged nylon fittings or clamps.

**8-127. INSTALLATION - PITOT-STATIC PIPING AND FITTINGS.**

a. Route pitot and static lines through clamps in place. Tighten clamps, Connect pitot and static lines to indicators and air data pressure transducer.

b. Apply silicone compound (C110) to threads of fitting couplings.

c. Connect nylon fittings. Torque coupling nuts fingertight.

d. Conduct functional check in accordance with paragraph 8-117.1.

**8-128. PITOT TUBE HEAD.**

**8-129. DESCRIPTION - PITOT TUBE HEAD.**



Serious burns may result if contact is made with pitot tube when pitot heater is ON.

The electrically heated pitot tube head and mount is located on upper left side of forward pylon fairing (figure 8-2). Information pertaining to the pitot heater electrical system is contained in paragraph 9-384.

**8-130. CLEANING - PITOT TUBE HEAD.**



Cleaning solvent is flammable and toxic. Provide adequate ventilation. Avoid prolonged breathing of solvent vapors and contact with skin or eyes.

a. Clean pitot tube head with a clean, lint-free cloth dampened with dry cleaning solvent (C112).

b. Clean mount with a clean, lint-free cloth dampened with dry cleaning solvent (C112)

### 8-131. INSPECTION - PITOTTUBE HEAD.

a. Inspect pitot tube for clogged or obstructed inlet opening, and clogged drain hole on bottom of tube (figure 8-2).

b. Inspect pitot tube for cracks or damage.

c. If pitot tube head is removed, inspect electrical receptacle, pins, and sockets for damage.

### 8-132. REMOVAL - PITOT TUBE HEAD.

a. Check that system electrical power is OFF.

b. Open access door on left center pylon fairing.

c. From inside the left forward pylon fairing, remove the clamps securing the pitot line and pitot heater electrical wires.

d. Disconnect union assembly and install protective caps on open ends.

e. From outside the helicopter, remove the three screws and lockwashers attaching pitot tube head to mount.

f. Carefully pull pitot tube from mount to expose electrical connector and pitot line coupling. Disconnect electrical connector. Disconnect coupling from adapter. Cap open adapter and tape electrical connector to prevent entrance of foreign material.

### 8-133. REPAIR - PITOT TUBE HEAD.

a. Replace pitot tube head if inlet opening is clogged or obstructed, drain hole is clogged, or electrical connector is damaged.

b. Replace pitot tube head if cracked or damaged to the extent it would restrict impact air pressure.

c. Replace defective or damaged pitot electrical connector.

d. Tighten or properly install fittings.

### 8-134. INSTALLATION - PITOT TUBE HEAD.

a. At pitot tube mount, remove protective cap from adapter and remove tape from electrical connector.

b. Apply silicone compound (C110) to threads of coupling.

c. Connect pitot line coupling to adapter. Torque coupling fingertight.

d. Connect electrical connector to pitot tube head connector.

e. Carefully position pitot tube into mount and install three mounting screws and lockwashers.

f. From inside left forward pylon fairing, remove protective caps from union and nut. Apply silicone compound (C110) to threads of union.

g. Connect union assembly. Torque union nut fingertight. Install pitot line clamp and electrical clamp.

h. Close pylon fairing access door.

### 8-135. AIRSPEED INDICATORS.

#### 8-136. DESCRIPTION - AIRSPEED INDICATORS.

The pilot and gunner airspeed indicators, located on respective instrument panel, are standard pitot-static instruments. The single-scale indicator provides airspeed indication of 20 to 250 knots by measuring differences between impact air pressure from the pitot tube and atmospheric pressure from the static pressure ports. **P E** Refer to figures 8-1 and 8-2 for equipment locations. **M** Refer to figure 8-2 and paragraph F-9 in Appendix F for equipment location.

#### 8-137. CLEANING - AIRSPEED INDICATORS.

Clean airspeed indicators in accordance with paragraph 8-3.

#### 8-138. INSPECTION - AIRSPEED INDICATORS.

Inspect airspeed indicators in accordance with paragraph 8-4.

**8-139. FUNCTIONAL CHECK - AIR-SPEED INDICATORS.**

Check airspeed indicators in accordance with paragraph 8-117.1.

**8-140. TROUBLESHOOTING - AIRSPEED INDICATORS.**

Use table 8-5 and perform necessary checks to isolate trouble.

**NOTE**

**Before you use this table, be sure you have performed all normal operational checks. If you have a malfunction which is not listed in this table, notify the next higher level of maintenance.**

Table 8-5. Troubleshooting Airspeed Indicators

---

**CONDITION**

**TEST OR INSPECTION**

**CORRECTIVE ACTION**

1. Indicators fail to respond.

STEP 1. Check for pressure line not connected.

**Connect line.**

2. Indicator pointer indicates incorrectly.

STEP 1. Check for lines clogged by water or dirt.

**Disconnect and blow lines clear, while actuating drain valve**

STEP 2. Determine if indicator is defective or leaking by substitution of known good indicator or perform functional check in accordance with paragraph 8-117.1.

**Replace indicator if defective (paragraph 8-1).**

---

**8-141. REMOVAL - AIRSPEED INDICATORS.**

Remove airspeed indicators in accordance with paragraph 8-5.

Repair airspeed indicators in accordance with paragraph 8-6.

**8-142. REPAIR - AIRSPEED INDICATORS.**

**8-143. INSTALLATION - AIRSPEED INDICATORS.**

Install airspeed indicators in accordance with paragraph 8-7.

8-144. ALTIMETERS.

8-145. DESCRIPTION - ALTIMETERS.

The pilot and gunner altimeters, located on respective instrument panel, furnish direct readings of helicopter height in feet above sea level. The altimeters are connected through piping to static pressure ports to sense atmospheric pressure. An external adjustment knob is provided to make compensation for variations of prevailing barometric pressure. The altimeters are equipped with vibrators to eliminate pointer sticking due to friction error. The vibrators are operated by 28 Vdc through the ALTM circuit breaker. **P E** Refer to figures 8-1 and 8-2 for equipment location. **M** Refer to figure 8-2 and paragraph F-9 in Appendix F for equipment location.

8-146. CLEANING - ALTIMETERS.

Clean altimeters in accordance with paragraph 8-3.

8-147. INSPECTION - ALTIMETERS.

Inspect altimeters in accordance with paragraph 8-4.

8-148. FUNCTIONAL CHECK - ALTIMETERS.

Functional check altimeters in accordance with paragraph 8-117.1.

8-149. TROUBLE SHOOTING - ALTIMETERS.

Use table 8-6 and perform necessary checks to isolate trouble. AA-32A encoding altimeter; code off flag will not drop and mode C will not test, see figure F-47.

**NOTE**

**Before you use this table, be sure you have performed all normal operational checks. If you have a malfunction which is not listed in this table, notify the next higher level of maintenance.**

**Table 8-6. Troubleshooting Altimeters**

---

**CONDITION**

**TEST OR INSPECTION**

**CORRECTIVE ACTION**

- Indicator has incorrect reading.

STEP 1. Check for leaks in static pressure line in accordance with paragraph 8-117.1.

**Correct leaks in line.**

STEP 2. Check for clogged static port or piping.

**Clean port or piping.**

STEP 3. Determine if indicator is defective by substitution of known good indicator or perform functional check in accordance with paragraph 8-117.1.

**Replace indicator if defective (paragraph 8-1).**

---

Table 8-7. Troubleshooting Attitude Indicators (Cont)

CONDITION
TEST OR INSPECTION
CORRECTIVE ACTION
STEP 2. Check for defective circuit breaker by use of multimeter or substitution of known good circuit breaker.
<b>Replace circuit breaker if defective (paragraph 9-23).</b>
STEP 3. Check for defective attitude gyro in accordance with TM 11-1520-236-20.
<b>Replace gyro if defective in accordance with TM 11-1520-236-20.</b>
2. Either pilot or gunner indicator display fails to erect to within $\pm 2$ degrees in pitch and roll within 3 minutes after turn on.
STEP 1. Check for defective indicator by substitution of known good indicator.
<b>Replace indicator if defective (paragraph 8-1).</b>
3. System functions properly, but gunner power OFF flag does not lift.
STEP 1. Check for defective indicator by substitution of known good indicator.
<b>Replace indicator if defective (paragraph 8-1).</b>

**8-163. REMOVAL - ATTITUDE INDICATORS.**

Remove attitude indicators in accordance with paragraph 8-5.

**8-164. REPAIR - ATTITUDE INDICATORS.**

Repair attitude indicators in accordance with paragraph 8-6.

**8-165- INSTALLATION - ATTITUDE INDICATORS.**

Install attitude indicators in accordance with paragraph 8-7.

**8-166. TURN AND SLIP INDICATING SYSTEM.**

**8-167. DESCRIPTION - TURN AND SLIP INDICATING SYSTEM.**

Turn and slip portion of the pilot and copilot attitude indicators consist of a rate of turn pointer (on pilot indicator only) and an inclinometer (ball) which operate independently of each other. Rate of turn pointer is controlled by an electrically actuated dc powered rate gyro and is protected by TURN SLIP circuit breaker. Rate of turn pointer indicates in which direction and at what rate helicopter is turning. Inclinometer (ball) indicates when helicopter is in directional balance either in a turn or in straight and level flight. If helicopter is yawing or slipping, ball will

be off center. **P E** Refer to figure 8-1 for equipment location and paragraph F-9 in Appendix F for wiring diagram. **M** Refer to paragraph F-9 in Appendix F for equipment location chart and wiring diagram.

8-168. VERTICAL SPEED INDICATORS.

8-169. DESCRIPTION - VERTICAL SPEED INDICATORS.

The pilot and gunner vertical speed indicators, mounted in the respective instrument panels are connected to the static air system to sense the rate of atmospheric pressure change. The indicators register ascent or descent in feet per minute. **P E** Refer to figure 8-1 and 8-2 for equipment locations. **M** Refer to figure 8-2 and paragraph F-9 in Appendix F for equipment location.

8-170. CLEANING - VERTICAL SPEED INDICATORS.

Clean vertical speed indicators in accordance with paragraph 8-3.

8-171. INSPECTION - VERTICAL SPEED INDICATORS.

Inspect vertical speed indicators in accordance with paragraph 8-4.

8-172. FUNCTIONAL CHECK - VERTICAL SPEED INDICATORS.

Functional check vertical speed indicators in accordance with paragraph 8-117.1.

8-173. TROUBLESHOOTING - VERTICAL SPEED INDICATORS.

Use table 8-8 and perform necessary checks to isolate trouble.

**NOTE**

**Before you use this table, be sure you have performed all normal operational checks. If you have a malfunction which is not listed in this table, notify the next higher level of maintenance.**

Table 8-8. Troubleshooting Vertical Speed Indicators

**CONDITION**

**TEST OR INSPECTION**

**CORRECTIVE ACTION**

1. Indicator points off zero.

STEP 1. Determine if mechanism shifted by substitution of known good indicator.

**Return pointer to zero by turning adjustment screw on face of instrument; tap face of indicator lightly while adjusting.**

2. Indicator has inaccurate readings.

STEP 1. Check for defective indicator by substitution of known good indicator.

**Replace indicator if defective (paragraph 8-1).**



Table 8-8. Troubleshooting Vertical Speed Indicators (Cont)

---

CONDITION

TEST OR INSPECTION

CORRECTIVE ACTION

STEP 2. Check for loose connection in static line.

Tighten connections.

STEP 3. Determine if indicator case leaks by substitution of known good indicator or in accordance with paragraph 8-117.1.

Replace indicator if defective (paragraph 8-1).

3. Indicator has excessive pointer oscillation.

STEP 1. Check for leaks in static line in accordance with paragraph 8-117.1.

Tighten connections; replace leaky lines.

STEP 2. Check for defective indicator by substitution of known good indicator.

Replace indicator if defective (paragraph 8-1).

---

8-174. REMOVAL - VERTICAL SPEED INDICATORS.

Remove vertical speed indicators in accordance with paragraph 8-5.

8-175. REPAIR - VERTICAL SPEED INDICATORS.

Repair vertical speed indicators in accordance with paragraph 8-6.

8-176. INSTALLATION - VERTICAL SPEED INDICATORS.

Install vertical speed indicators in accordance with paragraph 8-7.

8-177. **M** FIRE AND FLIGHT AIR DATA SUBSYSTEM (ADS).

8-178. **M** DESCRIPTION - FIRE AND FLIGHT AIR DATA SUBSYSTEM (ADS).

The ADS consists of a wind direction, speed, and temperature detector (AADS), a signal processor unit (EPU), and an airspeed and direction indicator (LA1). The ADS provides helicopter subsystems with air data information to aid flight safety at low airspeeds, to contribute to accurate fire control, and to provide backup navigation capability. The ADS displays forward, aft, and lateral components of airspeed up to 50 knots in any direction and also supplies electronic signals to the fire control computer and doppler navigation system. Refer to TM 9-1270-219-13 for description, operational check, troubleshooting, and maintenance of the ADS.

8-179. **M** WIND DIRECTION, SPEED, AND TEMPERATURE DETECTOR (AADS).

8-180. **M** DESCRIPTION - WIND DIRECTION, SPEED, AND TEMPERATURE DETECTOR (AADS).

The AADS is a part of the ADS. The AADS is a swiveling pitot-static probe which samples local

airflow pitot and static pressures, the angles of that airflow relative to the aircraft, and the free stream air temperature. Pneumatic pressure outputs are fed through the aircraft plumbing to the EPU and converted into analog electronic signals. Electronic signals representing airflow angle and temperature are also fed to the EPU. Component airspeed outputs from the EPU are displayed on the low airspeed indicator. Refer to TM9-1270-219-13 for description, operational check, troubleshooting, and maintenance of the AADS.

**8-181. M SIGNAL PROCESSOR UNIT (EPU).**

**8-182. M DESCRIPTION - SIGNAL PROCESSOR UNIT (EPU).**

The EPU, located on bulkhead behind pilot seat, receives pneumatic and electronic signals from the

AADS and radar altimeter. The EPU converts these signals into airspeed, temperature, and pressure output signals for the LAI, fire control computer, and doppler navigation system. Refer to TM 9-1270-219-13 for description, operational check, troubleshooting, and maintenance of the EPU.

**8-183. M AIRSPEED AND DIRECTION INDICATOR (LAI).**

**8-184. DESCRIPTION - AIRSPEED AND DIRECTION INDICATOR (LAI).**

The LAI is a part of the ADS. The indicator displays forward, aft, and lateral components of airspeed up to 50 knots in any direction. A three-position flag is provided to indicate system operational, system failure, or an over-range condition. Refer to TM 9-1270-219-13 for description, operational check, troubleshooting, and maintenance of the LAI.

**SECTION IV. NAVIGATION INSTRUMENTS**

**8-185. NAVIGATION INSTRUMENTS.**

**8-186. DESCRIPTION - NAVIGATION INSTRUMENTS.**

Navigation instruments include the horizontal situation indicator, radio magnetic indicator, and standby compass.

**8-187. HORIZONTAL SITUATION INDICATOR.**

**8-188. DESCRIPTION - HORIZONTAL SITUATION INDICATOR.**

The horizontal situation indicator is located in the pilot instrument panel. The indicator is used in conjunction with Gyro-magnetic Compass System (AN/ASN-43), ADF (AN/ARN -89B), VHF-FM Radio (AN/ARC-114A) operating in homing mode, and VOR-LOC-GS-MB System (AN/ARN-123). Navigation functions of the indicator are controlled by HSI Display Control Panel. Refer to TM 11-1520-236 series manuals for description, operational check, troubleshooting, and maintenance of system components.

**8-189. RADIO MAGNETIC INDICATOR.**

**8-190. DESCRIPTION - RADIO MAGNETIC INDICATOR.**

The radio magnetic indicator (RMI) is mounted in gunner instrument panel. The indicator gives gyromagnetic (AN/ASN-43) compass heading. Pointer number 1 indicates magnetic bearing of ADF (AN/ARN-89B). Pointer number 2 indicates magnetic bearing of VOR(AN/ARN-123). Refer to TM 11-1520-236 series manual for description, operational check, troubleshooting, and maintenance of system components.

**8-191. STANDBY MAGNETIC COMPASS.**

**8-192. DESCRIPTION - STANDBY MAGNETIC COMPASS.**

One standby compass of standard magnetic type is mounted on right windshield support. The standby compass is utilized by both pilot and gunner. The compass correction card is located adjacent to the compass. Refer to figure 8-2 for equipment locations.

**8-193. CLEANING - STANDBY MAGNETIC COMPASS.**

Clean standby magnetic compass in accordance with paragraph 8-3.

**8-194. INSPECTION - STANDBY MAGNETIC COMPASS.**

Inspect standby magnetic compass in accordance with paragraph 8-4.

**8-195. COMPENSATION (SWINGING) - STANDBY MAGNETIC COMPASS.**

The standby magnetic compass may be calibrated concurrently with the ASN-43 compass system.

Refer to TM 11-1520-236 series maintenance manuals.

**8-196. REMOVAL - STANDBY MAGNETIC COMPASS.**

Remove standby magnetic compass in accordance with paragraph 8-6.

**8-197. INSTALLATION - STANDBY MAGNETIC COMPASS.**

Install standby magnetic compass in accordance with paragraph 8-7.

**8-197.1. M GPS TRIMPACK.****8-197.2. .2. M DESCRIPTION - GPS TRIMPACK.**

The GPS trimpack is mounted on the left side of the pilot glare shield. The trimpack is a GPS navigation receiver which provides world-wide, day/night, all weather position and velocity.

**8-197.3. .3. M CLEANING - GPS TRIMPACK.**

Clean GPS trimpack in accordance with 8-3.

**8-197.4. .4. M INSPECTION - GPS TRIMPACK.**

Inspect GPS trimpack in accordance with 8-4.

**8-197.5. .5. M REMOVAL - GPS TRIMPACK.**

Remove GPS trimpack in accordance with 8-6.

**8-197.6. M INSTALLATION - GPS TRIMPACK.**

Install GPS trimpack in accordance with 8-7.

## SECTION V. MISCELLANEOUS INSTRUMENTS

### 8-198. MISCELLANEOUS INSTRUMENTS.

### 8-199. DESCRIPTION MISCELLANEOUS INSTRUMENTS.

The miscellaneous instruments include the free air temperature gage, fuel quantity indicating system, transmission oil temperature and pressure indicating system, voltmeter/ammeter, clock, **PE** pilot steering indicator (PSI), **M** head up display (HUD), radar warning system and **P** proximity warning system.

### 8-200. FREE AIR TEMPERATURE GAGE.

### 8-201. DESCRIPTION - FREE AIR TEMPERATURE GAGE.

The free air temperature gage is a bimetallic, probe type thermometer mounted on the left side of pilot compartment. The probe portion is exposed to outside temperatures through a rubber grommet mounted on skin of helicopter. The indicator is calibrated in degrees celsius. Refer to figure 8-2 for equipment locations.

### 8-202. CLEANING - FREE AIR TEMPERATURE GAGE.

Clean free air temperature gage in accordance with paragraph 8-3.

### 8-203. INSPECTION - FREE AIR TEMPERATURE GAGE.

Inspect and replace free air temperature gage if any of the following conditions exist:

- a. Discoloration.
- b. Leaking seals.
- c. Temperature indication reading does not agree with that of a standard indicator.

### 8-204. FUNCTIONAL TEST - FREE AIR TEMPERATURE GAGE.

Check temperature reading with that of a standard indicator known to be correct. (Refer to TM 55-1500-204-25/1). Replace gage if readings do not agree.

### 8-205. TROUBLESHOOTING - FREE AIR TEMPERATURE GAGE.

Use table 8-9 and perform necessary checks to isolate trouble.

**NOTE**

Before you use this table, be sure you have performed all normal operational checks. If you have a malfunction which is not listed in this table, notify the next higher level of maintenance.

**Table 8-9. Troubleshooting Free Air Temperature Gage**

---

**CONDITION**

**TEST OR INSPECTION**

**CORRECTIVE ACTION**

1. Gage has reading upscale of free air temperature.

STEP 1. Check for missing or improperly installed sunshield.

**Properly install sunshield.**

STEP 2. Determine if gage is defective in accordance with TM 1-1500-204-23 Series.

**Replace gage if defective (paragraph 8-200).**

2. Gage has reading downscale of free air temperature.

STEP 1. Check for defective gage in accordance with TM 1-1500-204-23 Series.

**Replace gage if defective (paragraph 8-200).**

---

**8-206. REMOVAL - FREE AIR TEMPERATURE GAGE.**

a. Unscrew and remove sunshield, dished washer, and one case washer from outer end of thermometer.

b. Remove thermometer and other case washer from inside of pilot compartment.

a. Hold washers and thermometer case in position at mounting flange (figure 8-2).

b. Insert probe through grommet and mounting flange.

c. Place sunshield over thermometer probe and tighten.

**8-207. REPAIR - FREE AIR TEMPERATURE GAGE.**

Replace gage if any of the inspection requirements are not met.

**8-209. FUEL QUANTITY INDICATING SYSTEM.**

**8-210. DESCRIPTION - FUEL QUANTITY INDICATING SYSTEM.**

The fuel quantity indicating system is a bridge capacitance, balance type system which includes a fuel quantity indicator, located on pilot instrument

**8-208. INSTALLATION - FREE AIR TEMPERATURE GAGE.**



panel, and two fuel quantity transmitters; one located in forward fuel cell, and the other located in aft fuel cell. The system is powered from the 115 Vac bus, and is protected by a 1 ampere FUEL QTY IND circuit breaker. Pressing FUEL GAUGE TEST SWITCH, located on the pilot miscellaneous control panel, checks the fuel quantity indicator for zero return. Fuel quantity indicator in pilot instrument panel registers fuel quantity in pounds. **P E** Refer to figure 8-1 for equipment locations. **M** Refer to paragraph F-9 in Appendix F for equipment location chart.

**8 - 2 1 1 . T R O U B L E S H O O T I N G F U E L Q U A N T I T Y I N D I C A T I N G S Y S T E M .**

Use table 8-10 and perform necessary checks to isolate trouble. Refer to paragraph F-9 in Appendix F for wiring diagram. Broken or shorted wiring is always a probable cause of malfunction or failure and has not been included.

**NOTE**

**Before you use this table, be sure you have performed all normal operational checks.** If you have a malfunction which is not listed in this table, notify the next higher level of maintenance.

Table 8-10. Troubleshooting - Fuel Quantity Indicating System

---

**CONDITION**

**TEST OR INSPECTION**

**CORRECTIVE ACTION**

1. Fuel quantity indicator reads low.

STEP 1. Determine if system is out of adjustment in accordance with paragraph 8-212 (AVIM).

Perform adjustment procedures (AVIM).

STEP 2. Check tank unit for low capacitance in accordance with paragraph 8-212 (AVIM).

**Replace tank unit if faulty (paragraph 8-220).**

STEP 3. Check for compensator capacitance too high in accordance with paragraph 8-212 (AVIM).

**Replace tank unit if faulty (paragraph 8-220).**

2. Fuel quantity indicator reads high.

STEP 1. Determine if system is out of adjustment in accordance with paragraph 8-212 (AVIM).

**Perform adjustment procedures (AVIM).**

STEP 2. Check tank unit for high capacitance in accordance with paragraph 8-212 (AVIM).

**Change tank unit if faulty (paragraph 8-220).**

Table 8-10. Troubleshooting - Fuel Quantity Indicating System (Cont)

---

CONDITION

TEST OR INSPECTION

CORRECTIVE ACTION

STEP 3. Check for open lead on compensator circuit.

**Repair wiring if defective.**

STEP 4. Check for compensator section of tank unit open in accordance with paragraph 8-212 (AVIM).

**Change tank unit if faulty (paragraph 8-220).**

3. Indicator remains at one point on scale.

STEP 1. Check for no power in accordance with paragraph 9-131.

**Repair 115 Vac power system (paragraph 9-125).**

STEP 2. Check for defective indicator by substitution of known good indicator in accordance with paragraph 8-212 (AVIM).

**Replace indicator if defective (paragraph 8-1).**

STEP 3. Check for grounded coaxial lead.

**Check wiring and/or replace indicator assembly.**

4. Indicator remains at zero or below.

STEP 1. Check for open wiring.

**Repair or replace wiring.**

STEP 2. Check for defective indicator by substitution of known good indicator or in accordance with paragraph 8-212 (AVIM).

**Replace indicator if defective (paragraph 8-1).**

5. Indicator operation is sluggish.

STEP 1. Check for low insulation of the circuit in accordance with paragraph 8-212 (AVIM).

**Repair or replace wiring and/or tank unit (paragraph 8-220).**

---



**8-212. FUNCTIONAL TEST - FUEL QUANTITY INDICATING SYSTEM - BENCH (AVIM).**

**NOTE**

Refer to paragraph 8-212.1 when using Tester T79.1.

a. Tank Unit Capacitance Test. Use capacitance bridge section of field calibration unit (T79), or equivalent, to measure capacitance between the coaxial and 400 Hertz receptacles, and also between the coaxial and compensator receptacles. When measuring the tank unit section on 381075-008 tank unit, ground compensator 400 Hertz connection. When measuring the compensator section, ground tank unit 400 Hertz connection. Ground tank unit flange to the measuring device while measuring capacitance. The unit capacitances should be as shown below. (Refer to figure 8-3).

<u>Tank Unit</u>	<u>Capacitance (pF)</u>
381075-008	126.4 ± 1.3
381065-007	97.4 ± 1.0
(Compensator)	25.0 ± 0.3

**NOTE**

Tolerance of measuring equipment must be taken into consideration in making all capacitance measurements

b. Tank Unit Insulation Resistance Test. Using the three wire insulation resistance tester, or insulation resistance section of field calibration unit (179), measured insulation resistance between points listed below. The mounting flange is considered "ground".

- (1) Center of coaxial connector to ground - not less than one megohm.
- (2) Center of 400 Hertz connector to ground - not less than one megohm.
- (3) Center of compensator connector to ground - not less than one megohm.
- (4) Center of coaxial connector to center of 400 Hertz connector of tank unit 381075-008- not less than 650 megohms.
- (5) Center of coaxial connector to center of 400 Hertz connector of tank unit 381065-007- not less than 850 megohms.
- (6) Center of maxial connector to center of compensator connector - not less than 3500 megohms.

c. Indicator Test.

- (1) Set up test circuit (figure 8-4).
- (2) Set up capacitance of 223.8 pF on tank unit section of tester and 50.7 pF on compensator section. Adjust empty control until pointer reads zero.
- (3) Set tank unit section of tester to 480.0 pF and leave compensator section set at 50.7 pF. Adjust full control until pointer reads 1975 pounds.
- (4) With compensator section set at 50.7 pF, vary tank unit section of tester so that pointer reads at graduations shown. Capacitance must be as shown opposite indicator reading.

<u>Indicator Reading (LBS X 100)</u>	<u>Capacitance (pF)</u>
0	223.8 ± 0.0
2	249.8 ± 1.3
4	275.7 ± 1.3
6	301.6 ± 1.3
8	327.6 ± 1.3
10	353.5 ± 1.3
12	379.5 ± 1.3
14	405.4 ± 1.3
16	431.3 ± 1.3
18	457.3 ± 1.3
19.75	480.0 ± 0.0

- (5) Cause Minor to travel from 0 to 1975 pounds and from 1975 to 0 pounds. The travel time must not be more than 30 seconds.
  - (6) Adjust tester so that indicator is upscale. Close test switch. Indicator should go to zero. Release test switch. Pointer should go back to its original position.
- d insulation Resistance Test. After all tank units and wiring have been installed in helicopter, test the insulation resistance of circuits. Use a three-wire insulation resistance tester and make the following insulation resistance tests at the amphenol connector. Disconnect connector from indicator prior to making tests and reconnect after tests are completed.
- (1) Between compensator (Pin D) and ground (pin J) - not less than one megohm.
  - (2) Between coaxial and ground - not less than one megohm.

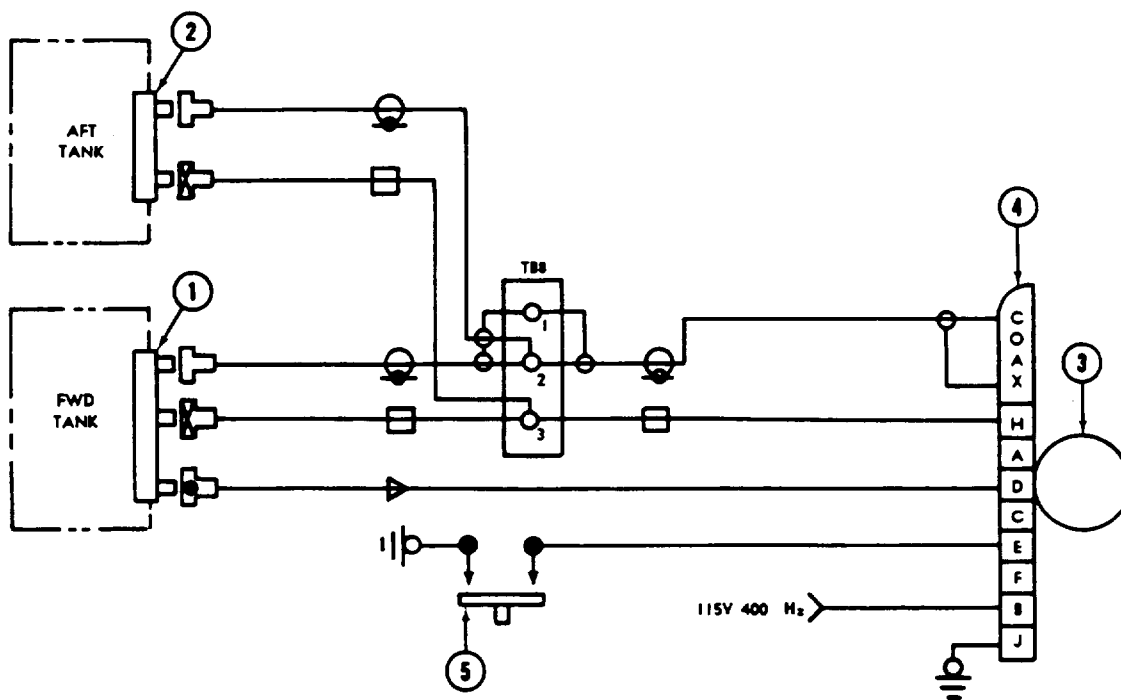

	PART NAME	PART NUMBER	REQD
1	TRANSMITTER (FWD)	209-060-602-9	1
2	TRANSMITTER (AFT)	209-060-602-11	1
3	INDICATOR	209-060-602-17	1
4	PLUG (AMPHENOL)	165-41	1
5	TEST SWITCH	MS25089-4C	1
	COAX PLUG (DAGE)	30-059-1B	1
	400 Hz PLUG (DAGE)	30-059-1A	2
	COAX PLUG (DAGE)	30-059-1F	2
	COAX LEAD		AS REQD
	400 Hz LEAD		"
	COAX CABLE		"

209475-373

Figure 8-3. Test Circuit Setup For Fuel Tank Unit Capacitance and Resistance Tests

(3) Between 400 Hertz (pin H) and ground - not less than one megohm.

(4) Between coaxial and 400 Hertz (Pin H) - not less than 350 megohms.

(5) Between coaxial and compensator (Pin D) - not less than 3000 megohms.

(6) Between 400 Hertz (Pin H and compensator (pin D) - not less than 10 megohms.

(7) Use bridge section of field calibration unit (T79), or equivalent, to measure capacitance of tank circuit. Ground compensator lead (Pin D) at indicator when measuring tank section, and ground tank section (Pin H) at indicator when measuring the compensator. The values should be as listed in Table 8-11.

e. Adjustment Procedure - Preferred Method With Fuel Tanks Empty. Adjust fuel tank gage as follows:

(1) Check that all connecting cables and units have been installed properly, and connections are tight.

(2) Make sure all tanks are empty and turn on power.

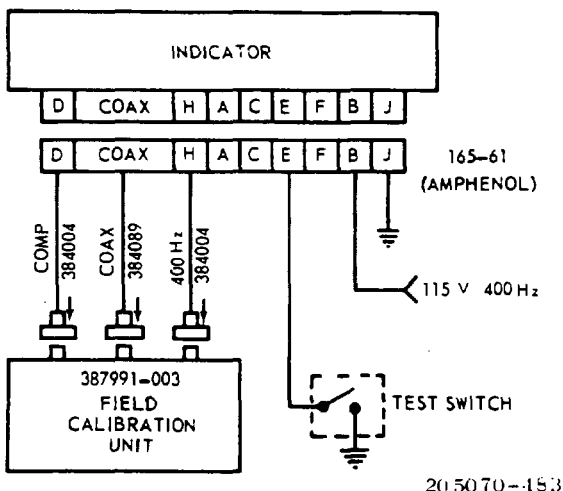

Figure 8-4. Test Circuit Setup For Fuel Quantity Indicator Bench Test

Table 8-11. Fuel Tank Table of Limits

a. Tank Unit Empty Capacitance Values.		
Circuit	Capacitance	
Tank Unit (Dry)	223.8 ± 2.3 pF	
Compensator Section (Dry)	25.0 ± 0.5 pF	
b. Added and Full Capacitance Values.		
Capacitance	Indicator Readings	
	Added	Full (Pounds)
	256.2	480.0 1975

(3) Turn "EMPTY" control until indicator reads exactly zero.

(4) Connect field calibration unit (T79), or equivalent, in parallel with helicopter wiring (figure 8-5).

(5) Set compensator section of tester to 25.7 pF and the tank unit section to 256.2 pF.

(6) Adjust "FULL" control on indicator to cause pointer to read at last dial division (1975 pounds).

(7) Disconnect adapter cable and reconnect airframe wiring to indicator.

f. Adjustment Procedure - Alternate Method With Fuel in Tanks.

(1) Disconnect amphenol connector at indicator and insert adapter cable (figure 8-5). Connect field calibration unit (T79) and leave cables marked 1, 2, and 3 disconnected.

(2) Set compensator section of tester to 50.7 pF and tank unit section to 223.8 PF. Adjust the "EMPTY" control on indicator to cause pointer to read zero.

(3) Leave compensator section set at 50.7 pF and set tank unit section to 480.0 pF. Adjust "FULL"

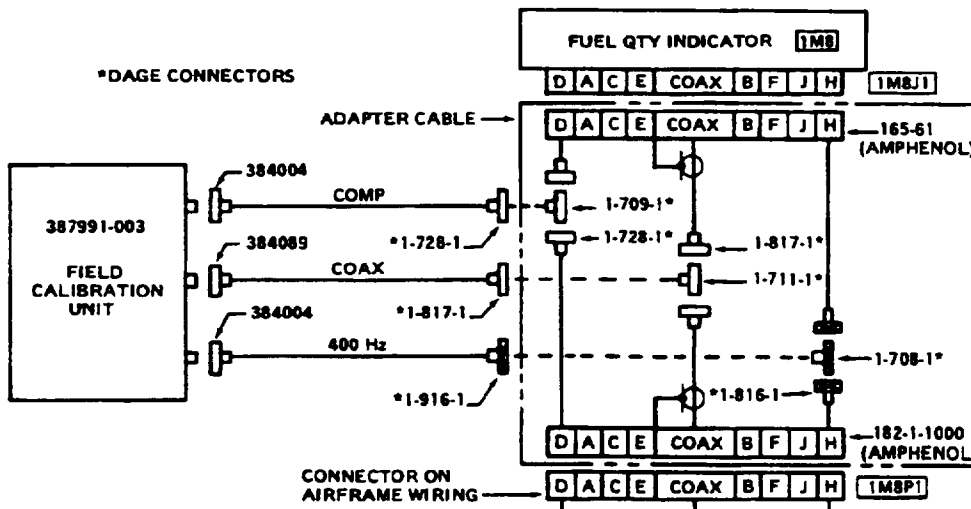

Figure 8-5. Circuit Arrangement and Adapter Cable for Fuel Quantity Adjustment Procedures On Installed System

control so that indicator pointer reads at last dial division (1975 pounds).

8-212.1. Test/Adjust-Fuel Quantity System (AVIM).

**WARNING**

Do not use any fuel quantity tester other than the PSD60-1AF with this procedure.

**WARNING**

Never connect a fuel gauge or signal conditioner unit (SCU) to an electrically live connector.

**WARNING**

If a circuit breaker pops during calibration or troubleshooting, a short circuit is indicated. Correct fault before reapplying power.

**WARNING**

Use only authorized test equipment to test, troubleshoot and calibrate the fuel quantity system. Shop testers including multimeters and meg/ohmmeters, are not certified safe for use on any wiring to the fuel tank.

**NOTE**

The fuel quantity system operational check can be used in either of two ways. The preferred method shall be used when the fuel tanks can be drained. The alternate method will be used when conditions do not allow fuel tanks to be drained i.e. combat/mobilization. Though the alternate method is considered adequate it is possible for residue to be trapped in the probe area which could indicate a false quantity.

a. Capacitance Test Using Tester (T79.1) and "T" cable (T79.2) Preferred Method Empty Tanks.

- (1) Ground aircraft to earth ground.
- (2) Completely drain sump and fuel tank(s) to be calibrated.
- (3) Verify that inverter which powers fuel quantity indicator is turned off.

**WARNING**

Always ground the tester to a good, clean aircraft ground Do not connect ground wire behind circuit breaker panels or near any exposed power termination.

(4) Connect tester chassis jack (J-7, figure 8-5.1) to airframe ground using ground leads-plied with tester.

(4) Lift to unlock tester ON-OFF switch and turn to "ON" position. If words "LO BAT" appear in

upper left-hand corner of LCD display (D-3) replace batteries in tester.

(6) Allow tester to warm up for at least 3 minutes before using.

(7) Connect "T" cable (figure 8-5.2) "LOZ", "HIZ", and "Comp" leads to TANK UNITS terminals (J-4, J-5, and J-6 figure 8-5.1) respectively on tester.

(8). Rotate tester FUNCT switch (S-2) to "MEASURE EXT position.

(9) Rotate tester SELECT switch(S-3) to "TU" POSITION.

(10) Switch TANK IN/OUT switch on "T" cable to the "IN" position.

**NOTE**

Worksheet figure 6-5.3 is to be locally reproduced.

(11) Read capacitance of "TU" test leads. If reading is over .5 pf, repair or replace cable. Record capacitance on worksheet, line 1.

(12) Rotate SELECT switch (S-3, figure 8-5.1) to "COMP" position. Read capacitance of COMP leads. If reading is over .5 pf, repair or replace cable. Record capacitance on worksheet, line 2.

(13) Loosen damp holding fuel quantity gauge in instrument panel and remove gauge from panel.

**CAUTION**

When disconnecting aircraft wiring cable from indicator hold cable to prevent retraction behind instrument panel.

(14) Disconnect aircraft wiring cable from fuel quantity gauge.

(15) Connect (J-1) of "T" cable to aircraft wiring connector removed from gauge. Do not connect to gauge.

(16) Read capacitance of empty tank plus cable and record on worksheet line 3.

(17) Subtract capacitance of cable measured in step 11 above from reaching in step 16. Capacitance must be between 221.5 pf and 226.5 pf.

**NOTE**

If tank capacitance is out of tolerance, check for trapped fuel at fuel drain.

(18) The tank unit capacitance should be as shown below:

Consolidated Airborne	or Simmonds	Capacitance
PAA	-381075-008	126.4± 1.3 pf
PAA	-381065-007	97.4 ±1.0 pf
(Compensator)		25.0 ± .3 pf

(19) Rotate SELECT switch (S-3) on tester to "COMP" position. Read capacitance of compensator plus cable capacitance on tester LCD. Record on worksheet line 4.

(20) Subtract cable capacitance measured in step 12 above from reading in step 19. Compensator capacitance must be between 24.5 pf and 25.5 pf. Record COMP capacitance on worksheet line 5.

(21) Rotate SELECT switch (S-3) on tester to "LOZ-HIZ" position.

**NOTE**

**The PSD60-1AF tester reads "over-range" above 10,000 megohms by flashing three colons and displaying four zeros.**

(22) Verify that the tester LCD reads over 20 megohms in "LOZ-HIZ" position. Record reading on line 7 of worksheet.

(23) Rotate SELECT switch (S-3) to the following positions and verify that the tester LCD reads over 1 megohm in each position:

"LOZ-SHLD"      "LOZ-GND"  
 "HIZ-SHLD"      "HIZ-GND"

Record readings on line 8 of worksheet.

(24) Rotate SELECT switch (S-3) to "SHLD-GND" position. Verify that LCD read-out indicates 0 megohms.

(25) Disconnect "T" cable leads from tester TANK UNITS terminals and connect to INDICATOR "LOZ", "HE" and "COMP" terminals respectively.

(26) Rotate tester FUNCT switch (S-2) to "MEASURE INT" position.

(27) Rotate SELECT switch (S-3) to the "COMP" position.

(28) Set COMP simulator decade (D-2) to read "00".

(29) Adjust COMP vernier (V-2) to read 25.7 pf on tester LCD display.

(30) Rotate SELECT switch (S-3) to "TU" position.

(31) Set TU simulator decade (D-1) to read "023".

(32) Adjust TU vernier (V-1) to read 256.2 pf on tester LCD display.

(33) Rotate FUNCT switch (S-2) to "AIR-CRAFT ONLY" position.

(34) Connect "T" cable (P-1) to fuel quantity indicator.

(35) Turn on inverter to power indicator.

**WARNING**

If a circuit breaker pops during calibration or troubleshooting, a short circuit is indicated. Correct fault before reapplying power.

(36) Press and release indicator test switch on instrument panel.

(37) Adjust "E" trimmer at lower left (viewed from front of gauge) until pointer reads 0 lb.

(38) Repeat steps 36 and 37 above until pointer returns to 0 lb.

(39) Rotate FUNCT SWITCH (S-2) on tester to "SIM TU & COMP" position.

(40) Adjust "F" trimmer at lower right (viewed from front of gauge) until pointer reads 1975 lb.

(41) Press and release indicator test switch on instrument panel.

(42) Repeat steps 40 and 41 until pointer returns 1975 lb.

(43) Repeat steps 32 through 36 above.

(44) Turn inverter off.

(45) Disconnect "T" cable from gauge and from aircraft wiring.

(46) Reconnect indicator aircraft wiring and reinstall in panel.

b. Capacitance Test Using Tester (T79.1) and "T" cable (179.2) Alternate Method Fuel In Tanks.

(1) Ground aircraft to earth ground.

(2) Verify that inverter which powers fuel quantity indicator is turned off.

**WARNING**

Always ground the tester to a good, clean aircraft ground. Do not connect ground wire behind circuit breaker panels or near any exposed power termination.

(3) Connect tester chassis jack (J-7, figure 8-5.1) to airframe ground using ground lead supplied with tester.

(4) Lift to unlock tester ON-OFF switch and turn to "ON" position. If words "LO BATT" appear in upper left-hand corner of LCD display (D-3) replace batteries in tester.

(5) Allow tester to warmup for at least 3 minutes before using.

(6) Connect "T" cable (figure 8-5.2) "LOZ", "HIZ", and "Comp" leads to TANK UNITS terminals (J-4, J-5, and J-8, figure 8-5.1) respectively on tester.

(7) Rotate tester FUNCT switch (S-2) to "MEASURE EXT" position.

(8) Rotate tester SELECT switch (S-3) to "TU" POSITION.

(9) Switch TANK IN/OUT switch on "T" cable to the "IN" position.

**NOTE**

Worksheet figure 8-5.3 is to be locally reproduced.

(10) Read capacitance of "TU" test leads. If reading is over .5 pf, repair or replaceable. Record capacitance on worksheet, line 1.

(11) Rotate SELECT switch (S-3, figure 8-5.1) to "COMP" position. Record capacitance of COMP lead. If reading is over .5 pf, repair or replace cable. Record capacitance on worksheet, line 2.

(12) Loosen damp holding fuel quantity gauge in instrument panel and remove gauge from panel.

**CAUTION**

When disconnecting aircraft wiring cable from indicator hold cable to prevent retraction behind instrument panel.

(13) Disconnect aircraft wiring cable from fuel quantity gauge.

(14) Connect (J-1) of "T" cable to aircraft wiring connector removed from gauge. Do not connect to gauge.

(15) Rotate SELECT switch (S-3) on tester to "LOZ-HIZ" position.

**NOTE**

**The PSD60-1AF tester reads "over-range" above 10,000 megohms by flashing three colons and displaying four zeros.**

(16) Verify that the tester LCD reads over 20 megohms in "LOZ-HIZ" position. Record readings on line 3 of worksheet

(17) Rotate SELECT switch (S-3) to the following positions and verify that the tester LCD reads over 1 megohm in each position:

"LOZ-SHLD"	"LOZ-GND"
"HIZ-SHLD"	"HIZ-GND"

Record readings on line 4 of worksheet

(18) Rotate SELECT switch (S-3) to "SHLD-GND" position. Verify that LCD read-out indicates 0 megohms.

(19) Disconnect "T" cable leads from tester TANK UNITS terminals and connect to INDICATOR "LOZ", "HIZ" and "COMP" terminals respectively.

(20) Rotate tester FUNCT switch (S-2) to "MEASURE INT" position.

(21) Rotate SELECT switch (S-3) to the "COMP" position.

(22) Set COMP simulator decade (D-2) to read "03".

(23) Adjust COMP vernier (V-2) to read 50.7 pf on tester LCD display.

(24) Rotate SELECT switch (S-3) to "TU" position.

(25) Set TU simulator decade (D-1) to read "020".

(26) Adjust TU vernier (V-1) to read 223.8 pf on tester LCD display.

(27) Rotate FUNCT switch (S-2) to "SIM TU & COMP" position.

(28) Connect "T" cable (P-1) to fuel quantity indicator.

(29) Switch the TANK IN/OUT switch on the interface cable to the "OUT" position.

(30) Turn on inverter to power indicator.

**WARNING**

If a circuit breaker pops during calibration or troubleshooting, a short circuit is indicated. Correct fault before reapplying power.

(31) Press and release indicator test switch on instrument panel.

(32) Adjust "E" trimmer at lower left (viewed from front of gauge) until pointer reads 0 lb.

(33) Repeat steps 31 and 32 above until pointer returns to 0 lb.

(34) Rotate FUNCT switch (S-2) on tester to "MEASURE INT" position.

(35) Set TU simulator decade (D-1) to red "046".

(36) Adjust TU vernier (V-1) to read 460.0 pf on tester LCD display.

(37) Rotate FUNCT switch (S-2) to "SIM TU & COMP" position.

(38) Adjust "F" trimmer at lower right (viewed from front of gauge) until pointer reads 1975 lb.

(39) Press and release indicator test switch on instrument panel.

(40) Repeat steps 38 and 39 until pointer returns to 1975 lb.

(41) Rotate FUNCT switch (S-2) on tester to "MEASURE INT" position.

(42) Repeat steps 25 through 32 above.

(43) Turn inverter off.

(44) Disconnect "T" cable from gauge and from aircraft wiring.

(45) Reconnect indicator to aircraft wiring and reinstall in panel.

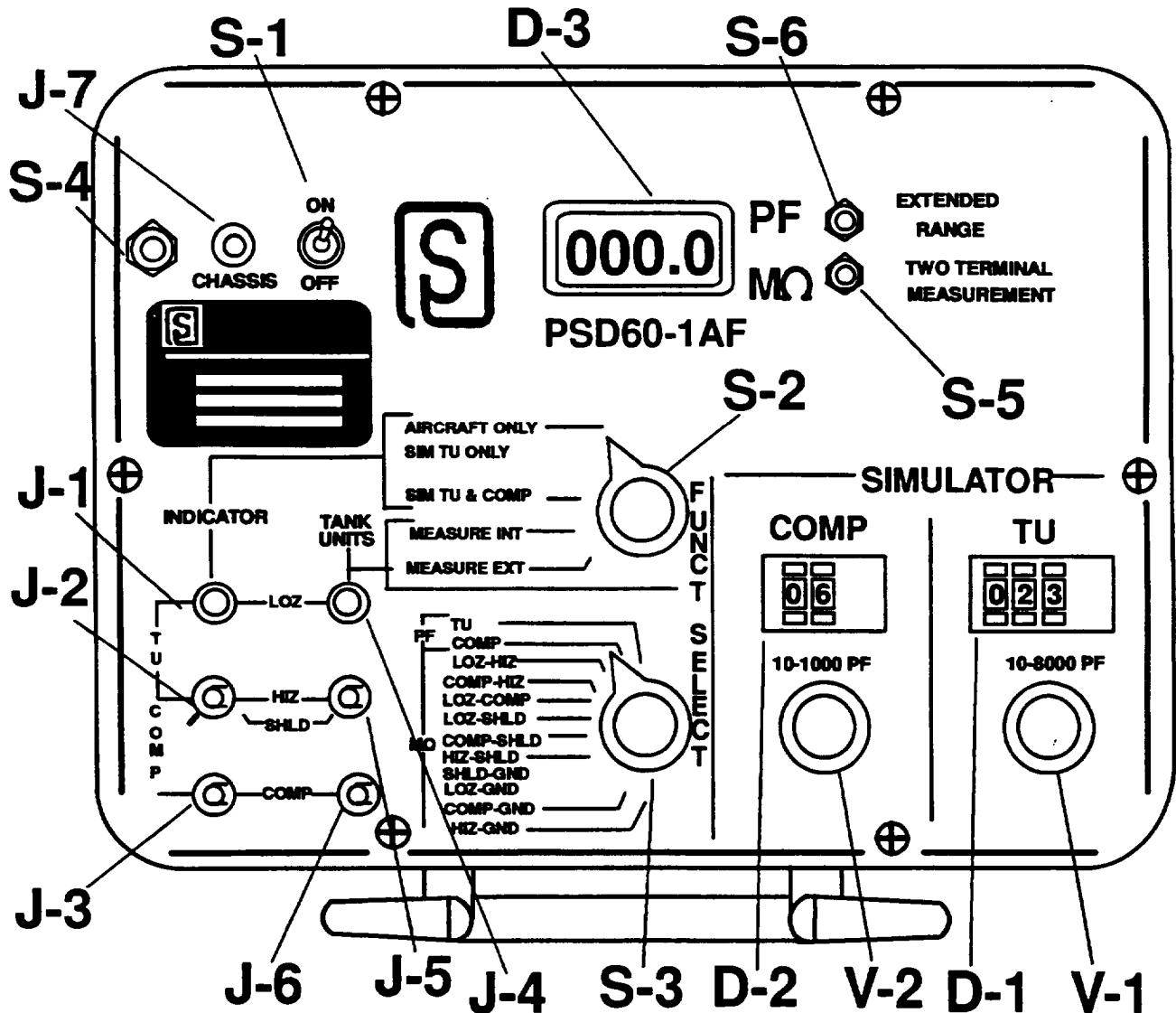

- J-1 LoZ output to indicator
- J-2 HiZ output to indicator
- J-3 Comp LoZ out to indicator
- J-4 Tank Unit Loz input
- J-5 Tank Unit HiZ input
- J-6 Tank Unit Comp input
- J-7 Airframe ground jack
- D-1 Tank Unit simulator decade
- D-2 Compressor sim decade
- D-3 Liquid Crystal Display (LCD)

- S-1 Power ON-OFF switch
- S-2 Function select switch
- S-3 Cap-Meg select switch
- S-4 Lid-close power OFF sw
- S-5 Press for 2-terminal  
megger readings
- S-6 X-10 range switch
- V-1 TU simulator vernier
- V-2 TU simulator vernier

Figure 8-5.1 Fuel Quantity Test Set P/N PSD60-1AF



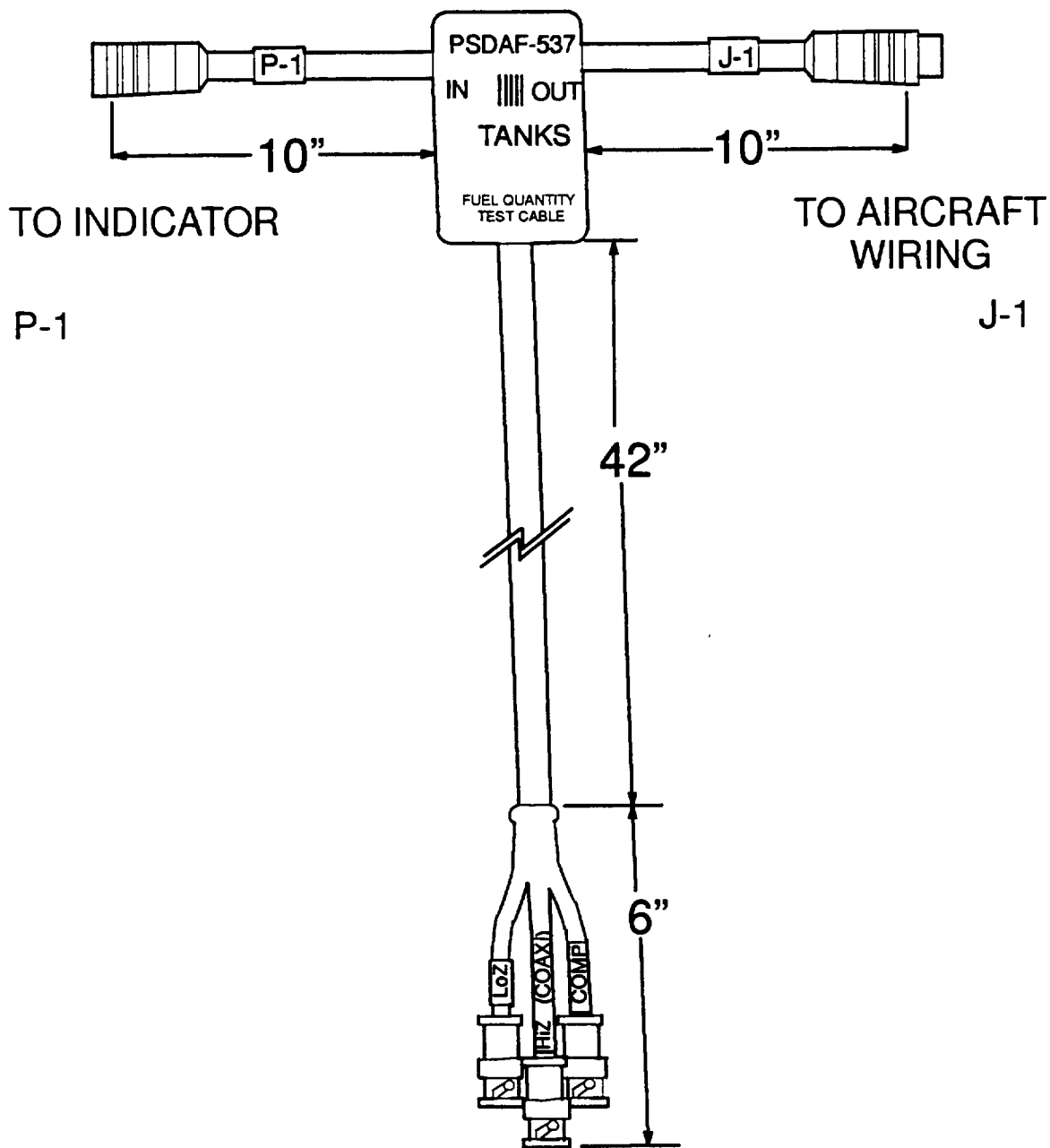

Figure 8-5.2 Fuel Quantity "T" Cable P/N PSDAF-537

<b>PERFERRED (DRY TANK) METHOD</b>	
1. Measure capacitance of cable TU leads .....	_____ pf
2. Measure capacitance of cable compensator leads .....	_____ pf
3. Measure capacitance of empty tank plus TU leads .....	_____ pf
4. Measure capacitance of compensator plus COMP leads .....	_____ pf
5. Subtract line 1 from 3 above. Empty tank compacitance = (223.5 pf - 226.1 pf) .	_____ pf
6. Subtract line 2 from 4 above. Empty COMP capacitance = (24.5 pf - 25.5 pf)	_____ pf
7. Measure LOZ-HIZ insulation resistance. Must exceed 20 meg	_____ meg
8. Measure insulation resistance of: Must exceed 1 Meg	
LOZ-SHLD	_____ meg
LOZ-GND	_____ meg
HIZ-SHLD	_____ meg
HIZ-GND	_____ meg
9. Measure insulation resistance SHLD-GND. Must read 0 meg .....	_____ meg
10. Select AIRCRAFT ONLY and adjust "E" for 0 lbs. ....	_____ lb
11. Select SIM TU & COMP and adjust "F" for 1975 lb. ....	_____ lb
12. Select AIRCRAFT ONLY and readjust "E" for 0 lb. ....	_____ lb
<b>ALTERNATE (FUEL IN TANK) METHOD</b>	
1. Measure capacitance of cable TU leads. ....	_____ pf
2. Measure capacitance of cable COMP leads. ....	_____ pf
3. Measure LOZ-HIZ insulation resistance. Must exceed 20 meg	_____ meg
4. Measure insulation resistance of: Must exceed 1 meg	
LOZ-SHLD	_____ meg
LOZ-GND	_____ meg
HIZ-SHLD	_____ meg
HIZ-GND	_____ meg
5. Measure insulation resistance SHLD-GND. Must read 0 meg .....	_____ meg
6. Adjust COMP simulator for 50.7 pf. Adjust TU simulator for 223.8 pf. Select SIM TU & COMP. Adjust "E" trimmer for 0 lb. ....	_____ lb
7. Adjust TU simulator for 480.0 pf. Select TU & COMP. Adjust "F" trimmer for 1975 lb. ....	_____ lb
8. Adjust TU simulator for 223.8 pf. Adjust "E" trimmer for 0 lb. ....	_____ lb

**NOTE: TO BE LOCALLY REPRODUCED**

FIGURE 8-5.3 FUEL QUANTITY CALIBRATION WORKSHEET

**8-213. FUEL QUANTITY INDICATOR.**

**8-214. Description-Fuel Quantity Indicator.** The fuel quantity indicator provides indications of fuel quantity in total pounds. The indicator is connected to two fuel quantity transmitters and powered by 115 Vac essential bus.

**[P] [E]** Refer to figure 8-1 for equipment location. **[M]** Refer to paragraph F-9 in Appendix F for equipment location chart.

**8-215. CLEANING - FUEL QUANTITY INDICATOR.**

Clean fuel quantity indicator in accordance with paragraph 8-3.

**8-216. INSPECTION - FUEL QUANTITY INDICATOR.**

Inspect fuel quantity indicator in accordance with paragraph 8-4.

**8-217. REMOVAL - FUEL QUANTITY INDICATOR.**

Remove fuel quantity indicator in accordance with paragraph 8-5.

**8-218. REPAIR - FUEL QUANTITY INDICATOR.**

Repair fuel quantity indicator in accordance with paragraph 8-6.

**8-219. INSTALLATION - FUEL QUANTITY INDICATOR.**

Install fuel quantity indicator in accordance with paragraph 8-7.

**8-220. FUEL QUANTITY TRANSMITTERS.****8-221. DESCRIPTION - FUEL QUANTITY TRANSMITTERS.**

Two fuel quantity transmitter probes are installed, one each in the forward and aft fuel cells, and are electrically connected to the fuel quantity indicating system. External ends of the transmitters are located in the hydraulic reservoir compartment at left side, and in the transmission compartment deck below the induction baffle and slightly to right of center. **[P] [E]** Refer to figure 8-1 for equipment locations. **[M]** Refer to paragraph F-9 in Appendix F for equipment location chart.



## 8-222. CLEANING - FUEL QUANTITY TRANSMITTERS.

a. Remove moisture and loose dirt with a clear soft cloth.

### **WARNING**

**Cleaning solvent is flammable and toxic. Provide adequate ventilation. Avoid prolonged breathing of solvent vapors and contact with skin or eyes.**

b. Remove oil, grease, fungus, and ground-in dirt with a clean, lint-free cloth dampened with dry cleaning solvent (C112).

c. Remove dirt from electrical connectors with a bristle brush.

d. Carefully clean the flange and connector housing of any residue pro-seal.

## 8-223. INSPECTION - FUEL QUANTITY TRANSMITTERS.

a. Inspect pressure transmitter for cracks, secure and proper mounting, and proper operation.

b. Inspect fuel line and fitting connection for leaks and proper, installation.

c. Inspect electrical connector for damaged or bent pins and cracked inserts.

## 8-224. REMOVAL - FUEL QUANTITY TRANSMITTERS.

a. Open left door of hydraulic reservoir compartment for access to forward fuel quantity transmitter.

b. Disconnect electrical connectors from transmitter.

c. Remove ram air intake duct.

d. Move ECU as required (paragraph 13-5).

e. Remove four bolts and washers from mounting flange, and remove the two frangible clips. Carefully withdraw transmitter upward from fuel cell, tilting as necessary for clearance. Cover open port.

f. Open transmission cowling and remove air induction baffle for access to aft fuel quantity transmitter.

g. Remove transmitter in same manner as for forward unit. (Refer to steps (b), (c), and (e).)

## 8-225. REPAIR - FUEL QUANTITY TRANSMITTERS.

a. Repair damaged electrical connections.

b. Replace transmitter if cracked.

c. Reinstall improperly mounted transmitter.

## 8-226. INSTALLATION - FUEL QUANTITY TRANSMITTERS.

### NOTE

**Forward and aft transmitters install in the same manner, except for location and parts removed for, access.**

a. Uncover fuel cell port. Place a new packing in groove of transmitter mounting flange. Insert transmitter carefully into cell. Install frangible clips for aft cell at aft and right side bolts. On forward fuel cell install frangible clips at forward and right side bolts. Install bolts and washers. Add bead of sealant around periphery of part.

b. Connect electrical connectors to transmitter. Perform a functional fuel quantity indicating system test. (Refer to paragraph 8-212.)

c. Apply a bead of pro-seal (C105) at the mating surface of the connector housing and the flange.

d. Reinstall parts removed for access. Close cowling or access doors.

## 8-227. TRANSMISSION OIL TEMPERATURE AND PRESSURE INDICATING SYSTEM.

## 8-228. DESCRIPTION - TRANSMISSION OIL TEMPERATURE AND PRESSURE INDICATING SYSTEM.

The transmission oil temperature and pressure indicating system consists of the transmission oil temperature and pressure indicator, transmission oil pressure transducer, and an electrical resistance type thermobulb. The system is powered from the 28 Vdc essential bus and protected by a 5 ampere TEMP IND ENG/XMSN circuit breaker.

**8-229. TROUBLESHOOTING - TRANSMISSION OIL TEMPERATURE AND PRESSURE INDICATING SYSTEM.**

Troubleshoot system in accordance with procedures contained in Table 8-2.

**8-230. TRANSMISSION OIL TEMPERATURE AND PRESSURE INDICATOR.**

**8-231. DESCRIPTION - TRANSMISSION OIL TEMPERATURE AND PRESSURE INDICATOR.**

The transmission oil temperature and pressure indicator, located in pilot instrument panel, indicates transmission oil pressure in psi and oil temperature in degrees celsius. The indicator is powered from the 28 Vdc essential bus and protected by a 5 ampere TEMP IND ENG/XMSN circuit breaker.

**8-232. CLEANING - TRANSMISSION OIL TEMPERATURE AND PRESSURE INDICATOR.**

Clean indicator in accordance with paragraph 8-3.

**8-233. INSPECTION TRANSMISSION OIL TEMPERATURE AND PRESSURE INDICATOR.**

Inspect indicator in accordance with paragraph 8-4.

**8-234. FUNCTIONAL TEST TRANSMISSION OIL TEMPERATURE AND PRESSURE INDICATOR.**

Functional test indicator in accordance with paragraphs 8-62 and 8-63.

**8-235. REMOVAL - TRANSMISSION OIL TEMPERATURE AND PRESSURE INDICATOR.**

Remove indicator in accordance with paragraph 8-5.

**8-236. REPAIR - TRANSMISSION OIL TEMPERATURE AND PRESSURE INDICATOR.**

Repair indicator in accordance with paragraph 8-6.

**8-237. INSTALLATION - TRANSMISSION OIL TEMPERATURE AND PRESSURE INDICATOR.**

Install indicator in accordance with paragraph 8-7.

**8-238. TRANSMISSION OIL PRESSURE TRANSDUCER.**

**8-239. DESCRIPTION - TRANSMISSION OIL PRESSURE TRANSDUCER.**

The transmission oil pressure transducer, located on right side of transmission, monitors transmission oil pressure and transmits voltage signals to the transmission oil pressure indicator. **PE** Refer to figure 8-1 for equipment locations. **M** Refer to paragraph F-9 in Appendix F for equipment location chart.

**8-240. CLEANING - TRANSMISSION OIL PRESSURE TRANSDUCER.**

Clean transducer in accordance with paragraph 8-69.

**8-241. INSPECTION TRANSMISSION OIL PRESSURE TRANSDUCER.**

Inspect transducer in accordance with paragraph 8-70.

**8-242. FUNCTIONAL TEST - TRANSMISSION OIL PRESSURE TRANSDUCER.**

Functional test transducer in accordance with paragraph 8-71.

**8-243. REMOVAL - TRANSMISSION OIL PRESSURE TRANSDUCER.**

- a. Remove cowling from transmission.
- b. Disconnect electrical connector.
- c. Cut lockwire and remove transducer.
- d. Cap openings in manifold and protect electrical connector with cap or tape.

**8-244. REPAIR - TRANSMISSION OIL PRESSURE TRANSDUCER.**

- a. Repair damaged electrical connectors.

b. Replace pressure transducer if cracked or damaged.

c. Reinstall improperly mounted pressure transducer.

**8-245. INSTALLATION - TRANSMISSION OIL PRESSURE TRANSDUCER.**

a. Install packing and lubricate with oil (C88 or C89).

b. Remove protective caps or tape and install transducer.

c. Install lockwire (137).

d. Connect electrical connector.

e. Install cowling.

**8-246. TRANSMISSION OIL TEMPERATURE BULB.**

**8-247. DESCRIPTION - TRANSMISSION OIL TEMPERATURE BULB.**

The transmission oil temperature bulb, installed in transmission oil manifold, monitors transmission oil temperature and transmits voltage signals to the transmission oil temperature and pressure indicator.

**P** Refer to figure 8-1 for equipment locations.

**M** Refer to paragraph F-9 in Appendix F for equipment location chart.

**8-248. CLEANING - TRANSMISSION OIL TEMPERATURE BULB.**

Clean temperature bulb in accordance with paragraph 8-77.

**8-249. INSPECTION - TRANSMISSION OIL TEMPERATURE BULB.**

Inspect temperature bulb in accordance with paragraph 8-78.

**8-250. REMOVAL - TRANSMISSION OIL TEMPERATURE BULB.**

Remove temperature bulb in accordance with paragraph 8-79.

**8-251. REPAIR - TRANSMISSION OIL TEMPERATURE BULB.**

Repair temperature bulb in accordance with paragraph 8-80.

**8-252. FUNCTIONAL TEST - TRANSMISSION OIL TEMPERATURE BULB - BENCH (AVIM).**

Functional test transmission bulb in accordance with paragraph 8-81.

**8-253. INSTALLATION - TRANSMISSION OIL TEMPERATURE BULB.**

Install temperature bulb in accordance with paragraph 8-82.

**8-254. VOLTMETER/AMMETER.**

**8-255. DESCRIPTION - VOLTMETER/AMMETER.**

The dc voltmeter, which is in the same case with ammeter, monitors and indicates voltage of the 28 Vdc essential bus. The dc voltmeter is protected by a 5 ampere DC VM circuit breaker. The dc ammeter indicates output in amperes of the generator portion of starter-generator. The dc ammeter is protected by two 5 ampere circuit breakers, one wired in series with positive lead, and the other wired in series with negative lead. The two dc ammeter circuit breakers are located in aft compartment below the generator-ammeter shunt.

**8-256. CLEANING - VOLTMETER/AMMETER.**

Clean voltmeter/ammeter in accordance with paragraph 8-3.

**8-257. INSPECTION - VOLTMETER/AMMETER.**

Inspect voltmeter/ammeter in accordance with paragraph 8-4.

**8-258. TROUBLESHOOTING - VOLTMETER/AMMETER.**

Use table 8-12 and perform necessary checks to isolate trouble. Refer to paragraph F-9 for wiring diagram. Broken or shorted wiring is always a probable cause of malfunction or failure and has not been included.

NOTE

Before you use this table, be sure you have performed all normal operational checks. If you have a malfunction which is not listed in this table, notify the next higher level of maintenance,

Table 8-12. Troubleshooting Voltmeter/Ammeter

---

CONDITION

TEST OR INSPECTION

CORRECTIVE ACTION

1. Indicator has no reading or erratic reading.

STEP 1. Check for open or short circuit in instrument by substitution of known good instrument.

**Replace indicator if defective (paragraph 8-1).**

STEP 2. Check for dirty or worn mechanism in instrument by substitution of known good instrument.

**Replace indicator if defective (paragraph 8-1).**

STEP 3. Check for instrument scale error in accordance with paragraph 8-261 (AVIM).

**Make adjustments to indicator (paragraph 8-261).**

---

**8-259. REMOVAL - VOLTMETER/AMMETER.**

Remove voltmeter/ammeter in accordance with paragraph 8-5.

(2) Dc millivoltmeter, 0 to 50 millivolts with 1/2 millivolt accuracy or better.

(3) Variable dc voltage source, 0 to 30 volts and sufficient current capability to drive the reference meter.

**8-260. REPAIR - VOLTMETER/AMMETER.**

Repair voltmeter/ammeter in accordance with paragraph 8-6.

**b. Test Procedure.**

(1) Connect the equipment as shown in figure 8-6.

**8-261. FUNCTIONAL TEST VOLTMETER/ AMMETER - BENCH (AVIM).**

**a. Test Equipment Required (figure 8-6).**

(2) With zero input to the voltmeter, adjust the mechanical zero adjustment so that it indicates zero. (For P/N 260173 only.)

(1) Dc voltmeter, 0 to 30 volt with 1/4 volt accuracy or better.

(3) With 50 millivolts input to ammeter, adjust mechanical zero adjustment so that it indicates 300 amperes. (For P/N 260173 only.)



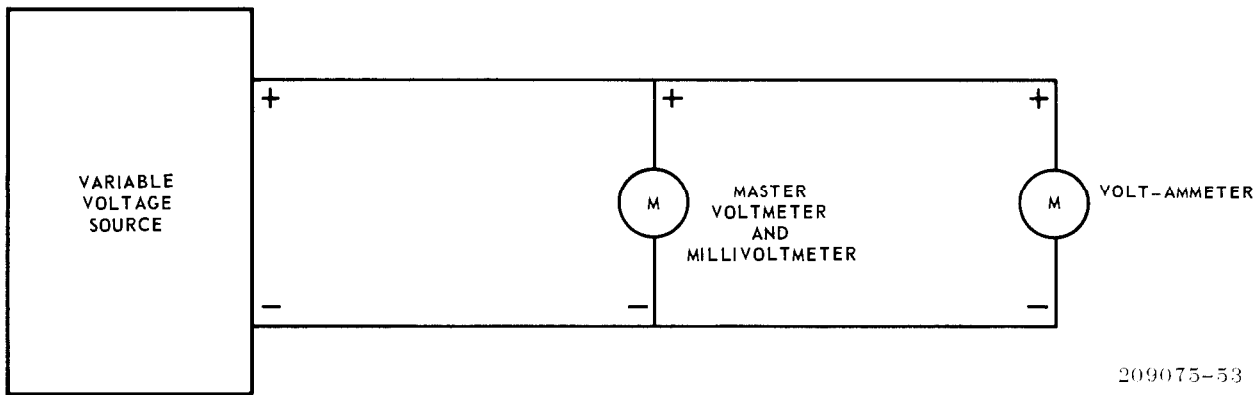

Figure 8-6. Volt-Ammeter Test Set-Up

### c. Movement Balance Test.

(1) Adjust voltage source so that volt-ammeter indicates any convenient reading on scale.

(2) Rotate instrument so that pointer is vertical and note indication.

(3) Rotate instrument so that pointer is horizontal and note indication.

(4) The difference between indications noted in steps (b) and (c) should not exceed two percent of full scale.

**d. Friction Test.** Vary voltage source so that indication of the volt-ammeter varies from zero to full scale. If any signs of pointers sticking are observed, stop and note indication before and after tapping meter. The friction error should not exceed two percent of full scale.

### e. Scale Error Test.

#### NOTE

**Support instrument in its normal operating position and tap or vibrate instrument before each reading.**

(1) Adjust voltage source so that master meter indicates a convenient value. Note indication of the volt-ammeter; it should not exceed **two** percent of master meter indication.

(2) Repeat step (1) above at a minimum of **five** equally spaced intervals over range of volt-ammeter.

### 8-262. INSTALLATION - VOLTMETER/AMMETER.

Install voltmeter/ammeter in accordance with paragraph 8-7.

### 8-263. CLOCK.

### 8-264. DESCRIPTION - CLOCK.

The clock, located on pilot instrument panel, is an 8 day clock with added stopwatch feature for elapsed time. The clock has a sweep-second pointer and a minute totalizer hand to indicate elapsed time. A control knob on the case starts pointers when pressed, stops both pointers when pressed a second time, and returns to 12 o'clock when pressed a third time. A separate control knob winds and sets the clock.

### 8-265. CLEANING - CLOCK.

Clean clock in accordance with paragraph 8-3.

### 8-266. INSPECTION - CLOCK.

Inspect clock in accordance with paragraph 8-4.

### 8-267. REMOVAL - CLOCK.

Remove clock in accordance with paragraph 8-5.

### 8-268. INSTALLATION - CLOCK.

Install clock in accordance with paragraph 8-7.

**8-269. P E PILOT STEERING INDICATOR (PSI).**

**8-270. P E DESCRIPTION - PILOT STEERING INDICATOR (PSI).**

The pilot steering indicator, mounted on top center of pilot instrument panel, is a component of the M65

TOW missile subsystem. The pilot steering indicator provides pilot with steering information for prelaunch helicopter alignment or postlaunch maneuver. The PSI also indicates status of attack and constraint boundaries. The visual display indicators and their functions are as follows:

Indicator	Function
ATTK annunciator.	Indicates when M65 is in attack mode.
RDY annunciator.	Indicates when M65 is in fire mode and pilot is flying within prelaunch constraints.
FIRE annunciator.	Indicates that gunner has initiated missile launch sequence.
Sightline position bars.	Vertical and horizontal bars indicate azimuth and elevation position of sightline with respect to helicopter reference axis and the prelaunch constraints boundary.
Reference ring.	Indicates helicopter reference axis.
Azimuth angle markers.	Fixed TSU azimuth angle limit references.
Course scale azimuth pointer.	Indicates TSU angular azimuth position within fixed angle limit references
Ascend-descend pointers	Indicates to pilot how to fly the pitch plane of helicopter in prelaunch condition. When helicopter flight path needs correction, only pointer which indicates correction sense will be displayed.
Prelaunch constraint boundary.	Indicates boundary within which pilot must keep sightline position bars during attack and fire modes.
Postlaunch constraint boundary.	Indicates boundary within which pilot must keep sightline position bars during maneuver mode.

The PSI visual display indicators are energized and actuated by the stabilization control amplifier (SCA). For additional information of M65 TOW missile subsystem, refer to TM 9-1425-473 series maintenance manuals.

**8-271. P E CLEANING - PILOT STEERING INDICATOR (PSI).**

- a. Remove dust and clean indicator cover glass with a clean, soft, lint-free cloth.
- b. Remove moisture with a clean, lint-free, dry cloth.

**8-272. P E INSPECTION - PILOT STEERING INDICATOR (PSI).**

- a. Inspect for loose, cracked, or broken cover glass.
- b. Inspect for security of mounting.

**8-273. P E FUNCTIONAL FUNCTIONAL TEST - PILOT STEERING INDICATOR (PSI).**

The PSI operational check is conducted as a portion of the M65 TOW missile subsystem operational test procedures. Refer to paragraph 9-427, 9-464.

**8-274. P E TROUBLESHOOTING - PILOT STEERING INDICATOR (PSI).**

Use table 8-13 and perform necessary checks to isolate trouble. Refer to paragraph F-9 in Appendix F for wiring diagram.

**NOTE**

**Before you use this table, be sure you have performed all normal operational checks, If you have a malfunction which is not listed in this table, notify the next higher level of maintenance.**

**Table 8-13. P E Troubleshooting Troubleshooting Pilot Steering Indicator (PSI)**

CONDITION

TEST OR INSPECTION

**CORRECTIVE ACTION**

1. One or more visual indicators inoperative.

STEP 1. Check for defective wiring from PSI to SCA

**Check continuity of wiring; repair defective wiring.**

STEP 2. Check for defective connector at PSI, tailboom disconnect, or SCA.

**Repair or replace defective connectors.**

STEP 3. Check for defective PSI by substitution of known good indicator or perform test in accordance with paragraph 8-273.

**Replace indicator if defective (paragraph 8-1).**

**8-275. P E REMOVAL - PILOT STEERING INDICATOR (PSI).**

- a. Ensure all system power is off.
- b. Remove mounting screws and carefully lift indicator out of shroud just far enough to expose electrical connector at rear of indicator.
- c. Disconnect electrical connector.
- d. Cap electrical connector on indicator and protect disconnected plug with electrical tape (C121).

**8-276. P E REPAIR - PILOT STEERING INDICATOR (PSI).**

- a. Replace indicator if cover is loose, cracked, or broken.
- b. Replace indicator if inoperative, defective, or damaged.

**8-277. P E INSTALLATION - PILOT STEERING INDICATOR (PSI).**

- a. Remove protective cap from electrical connector on indicator and remove protective tape from indicator plug.

b. Connect indicator plug to PSI and carefully position PSI in place in mounting shroud.

c. Install mounting screws.

**8-278. M HEAD UP DISPLAY SUBSYSTEM (HUDS).**

**8-279. M DESCRIPTION - HEAD UP DISPLAY SUBSYSTEM (HUDS).**

The HUDS display helicopter situation and weapons firing information in the pilot forward field of view. The HUDS functions automatically as a part of the fire control system. Operator control is limited to ON/OFF, day/night viewing settings, and mode selection. Refer to TM 9-1270-220-13 for description, operational check, troubleshooting, and maintenance of the HUDS.

**8-280. ROUNDS REMAINING INDICATOR.**

Refer to TM 9-1090-203-12 series manuals.

**8-281. RADAR WARNING SYSTEM (AN/APR-39) (PROVISIONS).**

**8-282. DESCRIPTION - RADAR WARNING SYSTEM.**

Provisions for the radar warning system is provided for pilot. The radar warning system provides pilot with both visual and audible warning when a high radar threat environment is encountered. The system is effectively operated by use of a control (located on pilot right console) and an indicator on instrument panel. Refer to TM 11-1520-236-20 for description, operational check, troubleshooting, and maintenance of system components. Refer to paragraphs 8-3 through 8-7 for instrument maintenance.

**8-283. ~ PROXIMITY WARNING SYSTEM.**

**SECTION VI. INSTRUMENT PANELS**

**8-285. INSTRUMENT PANELS.**

**8-286. DESCRIPTION - INSTRUMENT PANELS.**

The instrument panels are mounted on forward

**8-284. P DESCRIPTION - PROXIMITY WARNING SYSTEM.**

The proximity warning system consists of a receiver-transponder (YG-1054), two antennas, and a connection to the helicopter static air line. This system provides the pilot and gunner with audio/visual intrusion indications if a similarly equipped aircraft is within a radius of 5000 feet and within an altitude band of plus or minus 300 feet. The transmitter-receiver operates on a frequency of 5.08 GHz. A visual display consisting of flashing arrows indicates the altitude of the intruding aircraft relative to the altitude of the helicopter. An audio signal from the proximity warning system is connected directly to the helicopter intercommunication system and will be heard in all headsets. (Refer to TM 11-1520-236 series manuals for detailed description, operational check, troubleshooting, and maintenance of proximity warning system components.)

**8-284.1 M DESCRIPTION - LASER DETECTOR SET (AN/AVR-2) (AFTER MWO 55-1520-236-50-23).**

The laser detecting system consists of five components: four Sensors and a Comparator. The system interfaces with the Radar Warning System (APR-39) and receives "power-on" and "self-test" commands from the radar warning control. Laser threat and missile alert information is displayed on the radar warning indicator (CRT). The AVR-2 comparator monitors and processes signal lines from the APR-39 and controls information displayed on the radar warning indicator. In the event of simultaneous warnings from both radar warning and laser detecting sets, the laser detecting signals have priority. Together the two systems provide early warning against radar and laser threats. Refer to TM 11-1520-236-23 for detailed description, operational check, troubleshooting, and maintenance of system components.

**8-287. CLEANING - INSTRUMENT PANELS.**

a. Remove moisture and loose dirt with a clean, soft cloth.



**Cleaning solvent is flammable and toxic. Provide adequate ventilation. Avoid prolonged breathing of solvent vapors and contact with skin or eyes.**

b. Remove grease, fungus, and ground-in dirt with a clean, lint-free cloth dampened with dry cleaning solvent (C112).

**8-288. INSPECTION - INSTRUMENT PANELS.**

Visually inspect panels for surface scratches, warpage, cracks, and loose mounting screws.

**8-289. REMOVAL - INSTRUMENT PANELS.**

a. Ensure all electrical power is off.

b. Disconnect all electrical receptacles and hoses from instruments.

c. Cover all receptacles and hoses to prevent entrance of foreign particles.

d. Cover openings in instruments.

e. Remove mounting hardware and lift panel from helicopter.

**8-290. REPAIR - INSTRUMENT PANELS.**

a. Repair cracks in accordance with TM 55-1500-204-25/1.

b. Replace shock mount if warped.

c. Replace loose or worn mounting screws.

d. Touchup paint if damaged or deteriorated, using primer (C88) and lacquer (C65) in accordance with TB 746-93-2.

**8-291. INSTALLATION - INSTRUMENT PANELS.**

a. Install shock mounts if removed.

b. Position panel in place on console and install mounting hardware.

c. Connect electrical receptacles to instruments.

d. Apply silicone compound (C110) to threads of pitot-static fittings.

e. Connect nylon fittings, Torque coupling nuts finger tight.



## CHAPTER 9

## ELECTRICAL SYSTEMS

## SECTION I. ELECTRICAL SYSTEMS MAINTENANCE

## 9-1. ELECTRICAL SYSTEMS MAINTENANCE.

**WARNING**

Ensure armament system is safe before performing electrical operational checks. (Refer to WARNING page.)

**CAUTION**

Before performing any maintenance checks on electrical panel which require power be applied to the panel, open the panel before applying power and ensure no contact of energized panel is made with outside frame.

**NOTE**

Power loading charts and detail system wiring diagrams are contained in Appendix F. Aviation Unit Maintenance activities shall request Intermediate Maintenance assistance for electrical system repairs in accordance with the maintenance allocation chart, Appendix B.

## 9-2. PRIMARY ELECTRICAL POWER.

a. **P** The primary dc electrical power on the helicopter is a 28 volt direct current system supplied by the engine driven 30 volt, 300 ampere starter-generator (1MG1) derated to 200 amperes. Primary ac power is supplied by the 115 volt, 750 volt/ampere, 400 hertz, solid state, three-phase, delta-connected main inverter (3PS1), powered from the essential 28 volt dc bus.

b. **E M** The primary dc electrical power on the helicopter is provided by the engine driven 30 volt, (regulated to 28 volts) 200 ampere starter-generator (1MG1) and the 28 Vdc, 200 ampere transformer-rectifier unit (TRU). The primary ac electrical power is supplied by the 120/208 Volt, 3 phase wye connected 10 kva, 400HZ transmission driven alternator.

9-3. **P** EMERGENCY DC POWER.

In the event of starter-generator failure, dc power is supplied by the 24 volt, 22 ampere/hour battery (2BT1). The battery, assuming an 85 percent charge, can supply the essential loads under emergency conditions for a period of approximately 20 minutes.

## 9-4. EMERGENCY AC POWER.

a. **P** In the event of main inverter failure, ac power is supplied by the 115 volt, 250 volt/ampere, 400 Hz, rotary, single-phase standby inverter (3MG1). The standby inverter is powered from the non-essential 28 volt dc bus.

b. **~** In the event of transmission driven alternator failure, emergency ac power is supplied by the 115 volt, 750 Volt/ampere, 400 Hz, solid state, three phase, wye connected inverter (3PS1), powered from the power transfer bus.

## 9-5. ELECTRICAL BUS WIRING SCHEMATIC.

a. **P** A single-line, simplified electrical bus wiring schematic of the electrical power system is shown on figure 9-1. Primary power is distributed by a dual-bus arrangement so that non-essential dc loads are automatically de-energized in the event of a starter-generator failure. A bus-reset feature is provided to permit reactivation of these loads at pilot discretion.

b. **E M** A single line simplified electrical power distribution schematic of the electrical power system is shown on figure 9-2.

## 9-6. STARTING POWER.

Starting power is supplied by the 24 volt, 22 amp/hour battery or by an external ground power source.

## 9-7. CONTROL PANELS AND MISCELLANEOUS EQUIPMENT.

The control panels for the ac and dc electrical systems are located in the pilot and gunner consoles. The ac

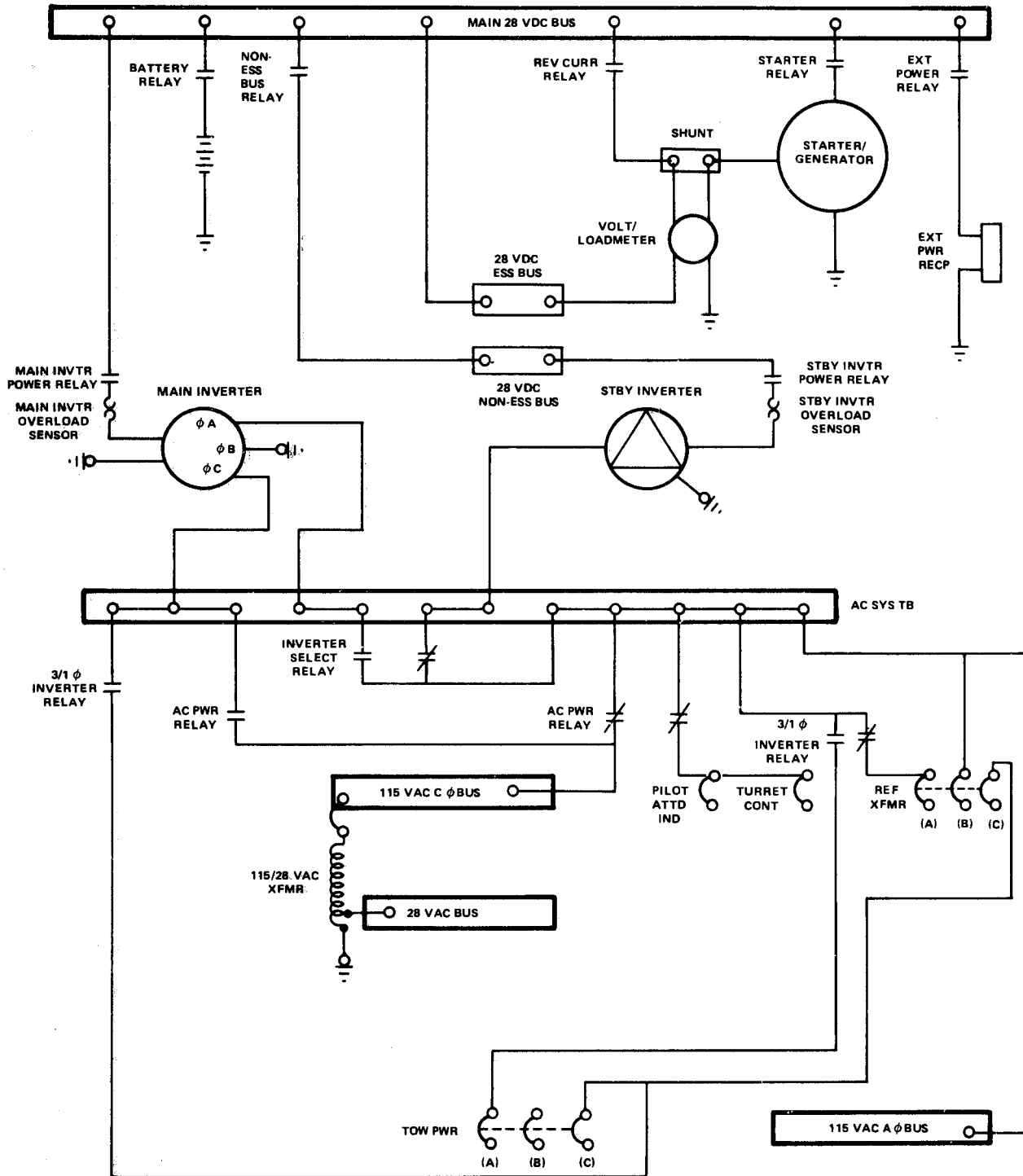

209475-374

Figure 9-1. P Simplified Electrical Bus Wiring Schematic



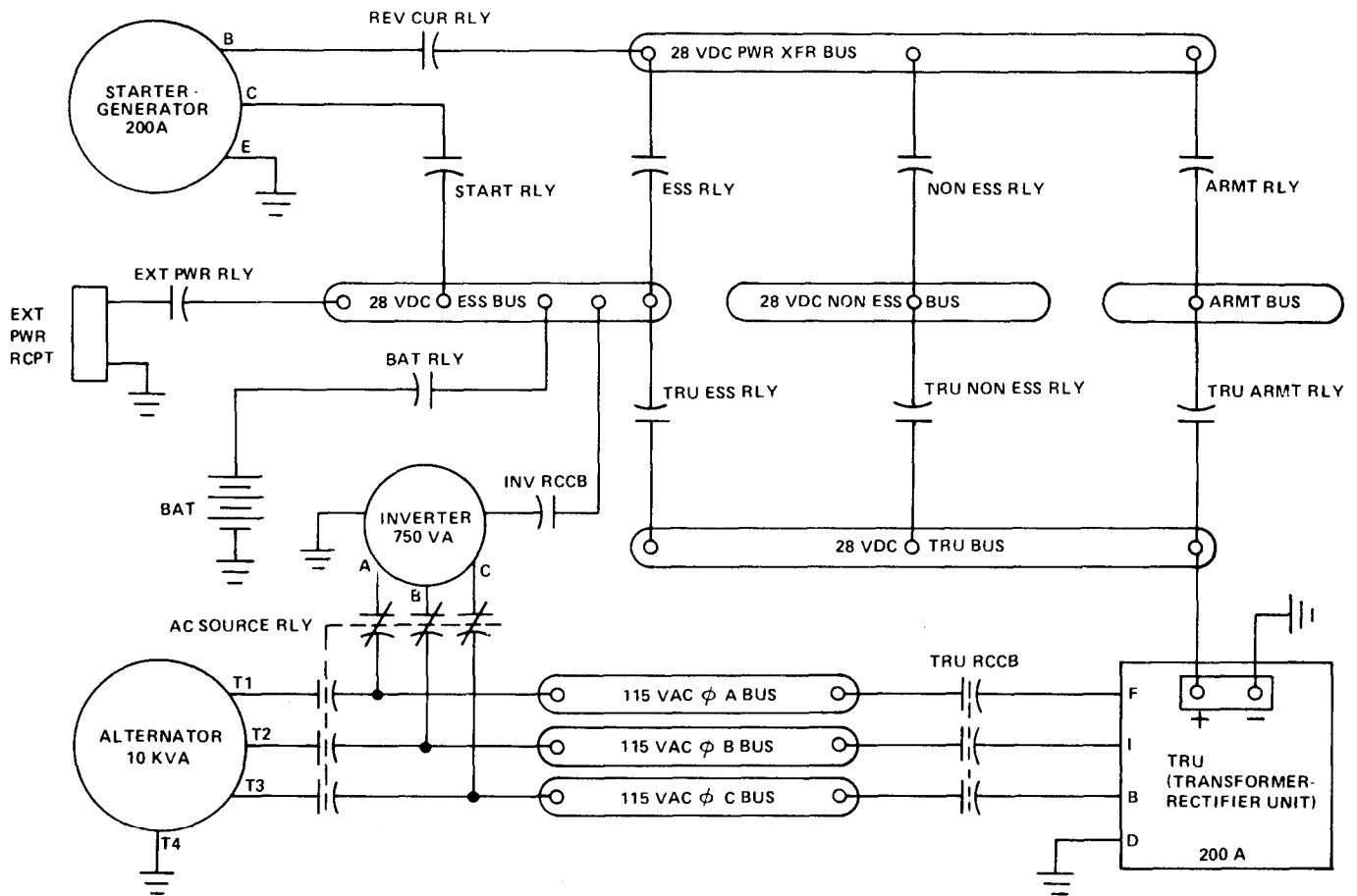

209475-446

Figure 9-2. **E M** Simplified Electrical Bus Wiring Schematic

and dc circuit breaker panels are located in the pilot console. Control relays, power relays, voltage regulator, transformers, and other equipment required to control, regulate, effect power transfer and for malfunction monitoring are located in the gunner and pilot sections (right and left wells) and aft compartment. Refer to figures 2-2 and 2-3 for location of access panels and doors. See figures 9-3 through 9-6 for configuration **P** and figures 9-7 through 9-10 for configuration **E** equipment location. Refer to paragraph F-9 in Appendix F for configuration **M** equipment location charts.

**9-8. GENERAL MAINTENANCE PROCEDURES.**

**NOTE**

Throughout this chapter, unless otherwise specified, electrical maintenance, testing, and troubleshooting procedures will utilize only

tools and equipment contained in electronic equipment tool kit (T20) and multimeter (T2) or equivalent.

**NOTE**

To measure voltage or resistance at terminal boards, switches, and relays with environmental type connectors, remove wire from connector and insert a locally fabricated tool in series as shown in figure 9-11. Measurements may then be taken from clip to airframe ground, etc.

**9-9. VISUAL INSPECTION - ELECTRICAL EQUIPMENT.**

Inspect electrical and electronic equipment for dirt and corrosion. The surfaces should be free of dirt, grease, and fungus.

- a. Remove moisture, dust, and loose dirt with a clean soft cloth.

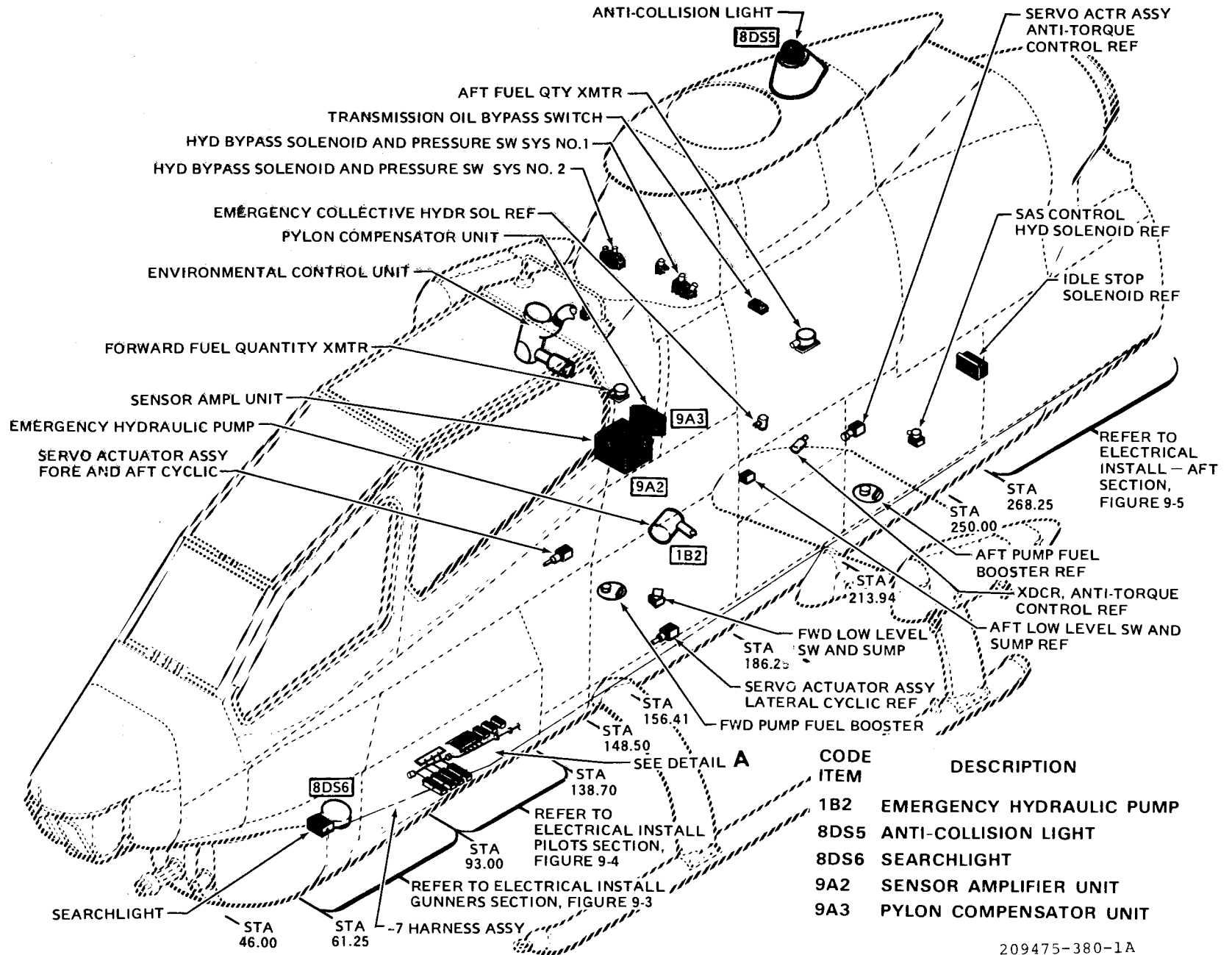
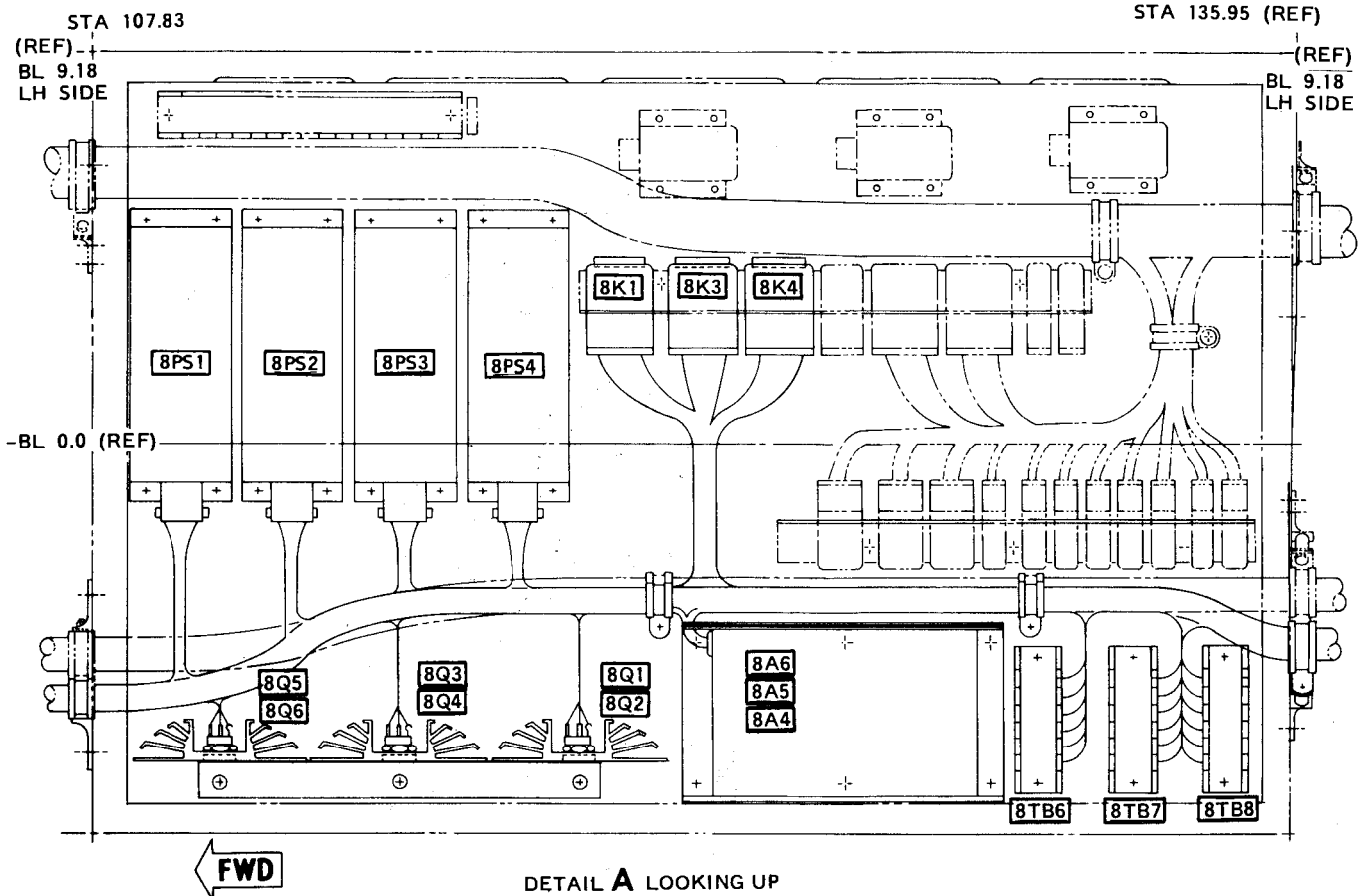

Figure 9-3. **P** Electrical Equipment Location — Forward Section (Sheet 1 of 2)



DETAIL A LOOKING UP

CODE ITEM	DESCRIPTION
8A4	PC Board - NVG
8A5	PC Board - NVG
8A6	PC Board - NVG
8K1	Relay - Gunner NVG
8K3	Relay - Pilot NVG
8K4	Relay - Pilot NVG
8PS1	Power Supply - Gunner Instrument Light
8PS2	Power Supply - Pilot Tactical Instrument Light
8PS3	Power Supply - Pilot Flight Instrument Light
8PS4	Power Supply - Pilot Engine Instrument Light
8Q1	Transistor - NVG
8Q2	Transistor - NVG
8Q3	Transistor - NVG
8Q4	Transistor - NVG
8Q5	Transistor - NVG
8Q6	Transistor - NVG
8TB6	Terminal Board - Pilot NVG Lighting
8TB7	Terminal Board - Pilot NVG Lighting
8TB8	Terminal Board - Gunner NVG Lighting

209475-380-2A

Figure 9-3. P Electrical Equipment Location - Forward Section (Sheet 2 of 2)

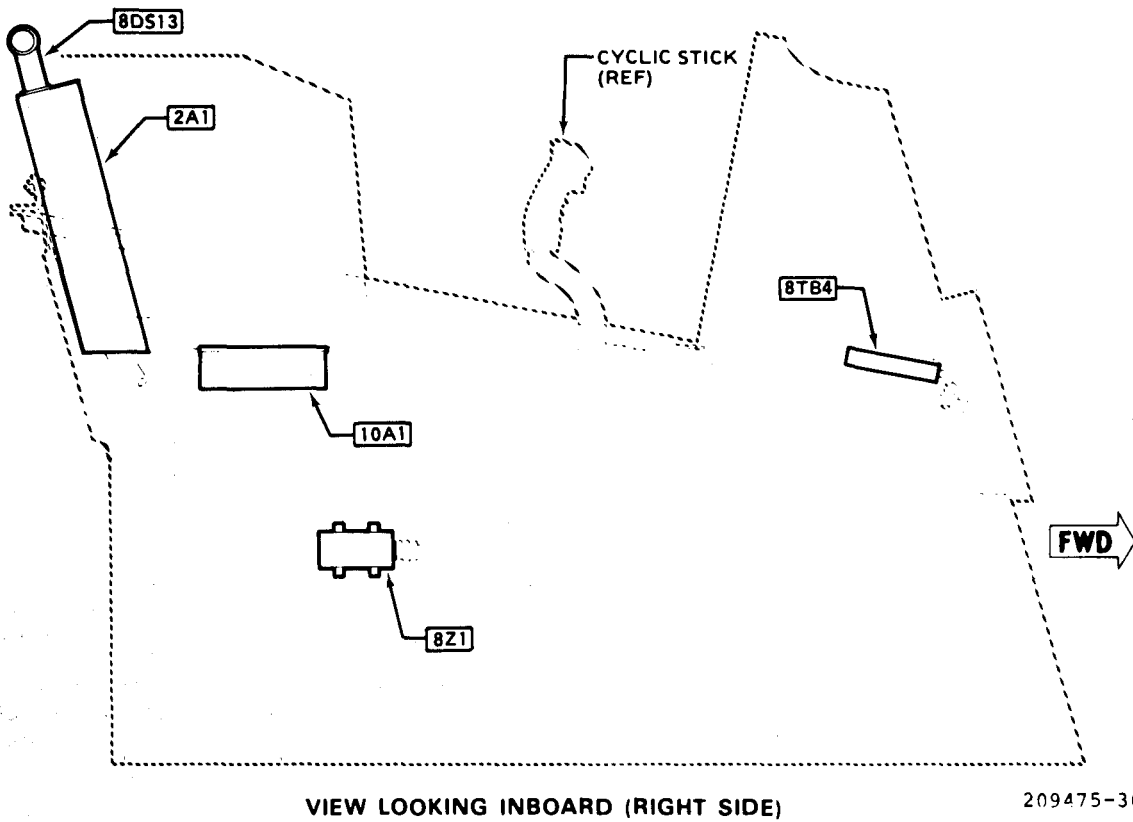
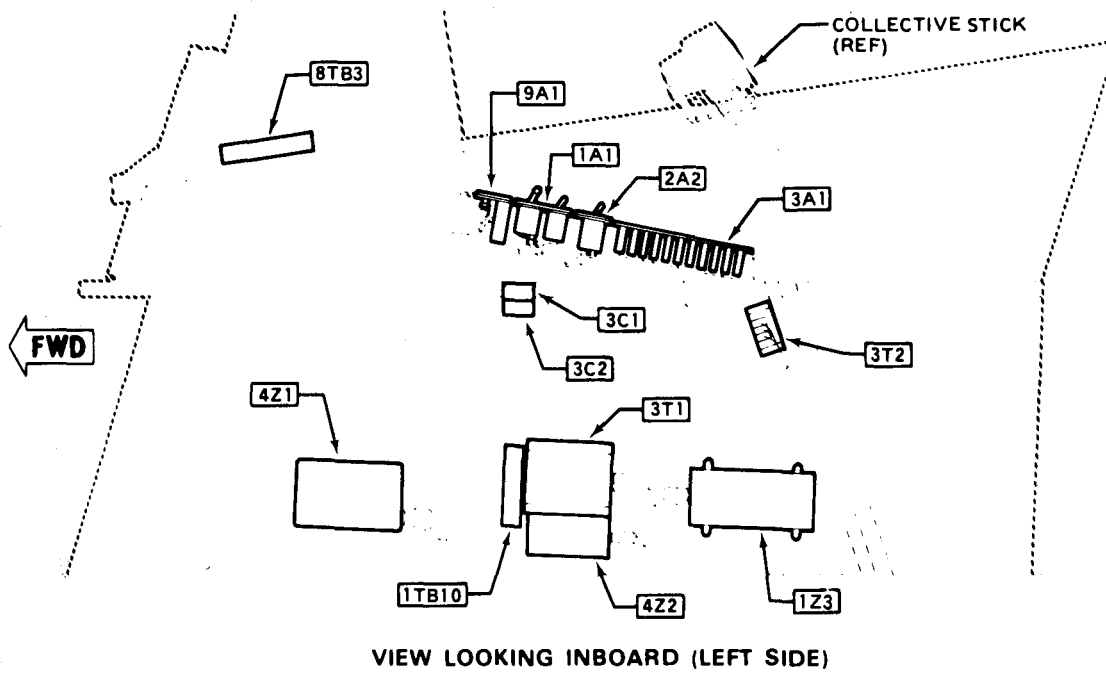

209475-361-1A

Figure 9-4. **P** Electrical Equipment Location - pilots section (sheet 1 of 2)

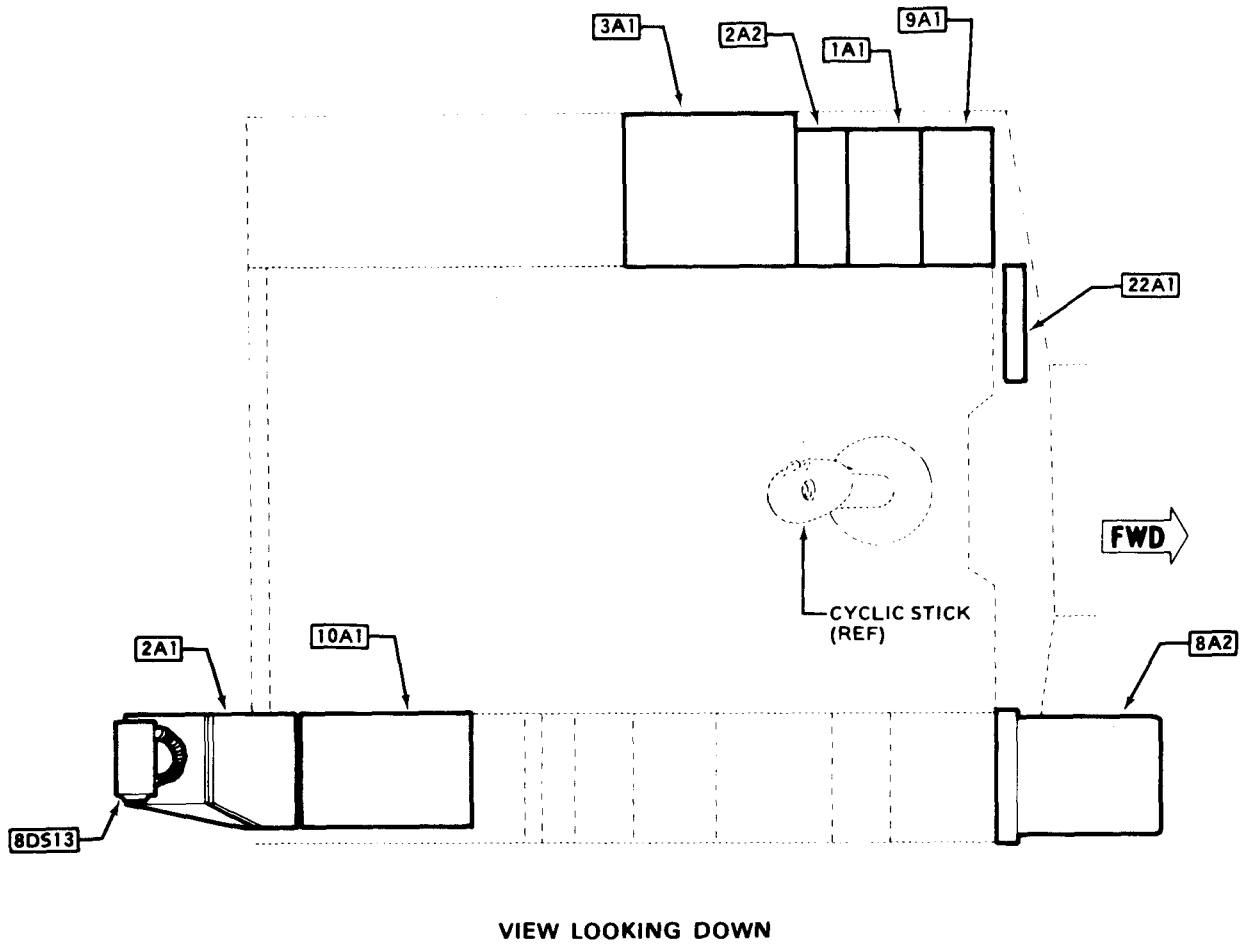

209475-361-2A

CODE ITEM	DESCRIPTION	cODE ITEM	DESCRIPTION
1A1	Panel assembly, engine control	421	Gyro, attitude
1TB10	Terminal board, attitude indicator	4Z2	Transmitter, rate gyro
1Z3	RPM limit detector	TDR 3905	Panel assembly, pilots caution
2A1	Panel assembly, DC circuit breaker	8DS13	Light, pilots cockpit
2A2	Panel assembly, electric power	8T83	Terminal board, pilot instrument ground
3A1	Panel assembly, AC circuit breaker	8TB4	Terminal board, lighting and caution
3C1	Capacitor, power factor correction	821	Flasher, NAV light
3C2	Capacitor, power factor correction	9A1	Panel assembly, SCAS control
3T1	Transformer, reference	10A1	Panel assembly, pilots lighting/ECS
3T2	Transformer, 11 5/28 Vac	22A1	Panel assembly, pilots miscellaneous

Figure 9-4. **P** Electrical Equipment Location - Pilots Section (Sheet 2 of 2)

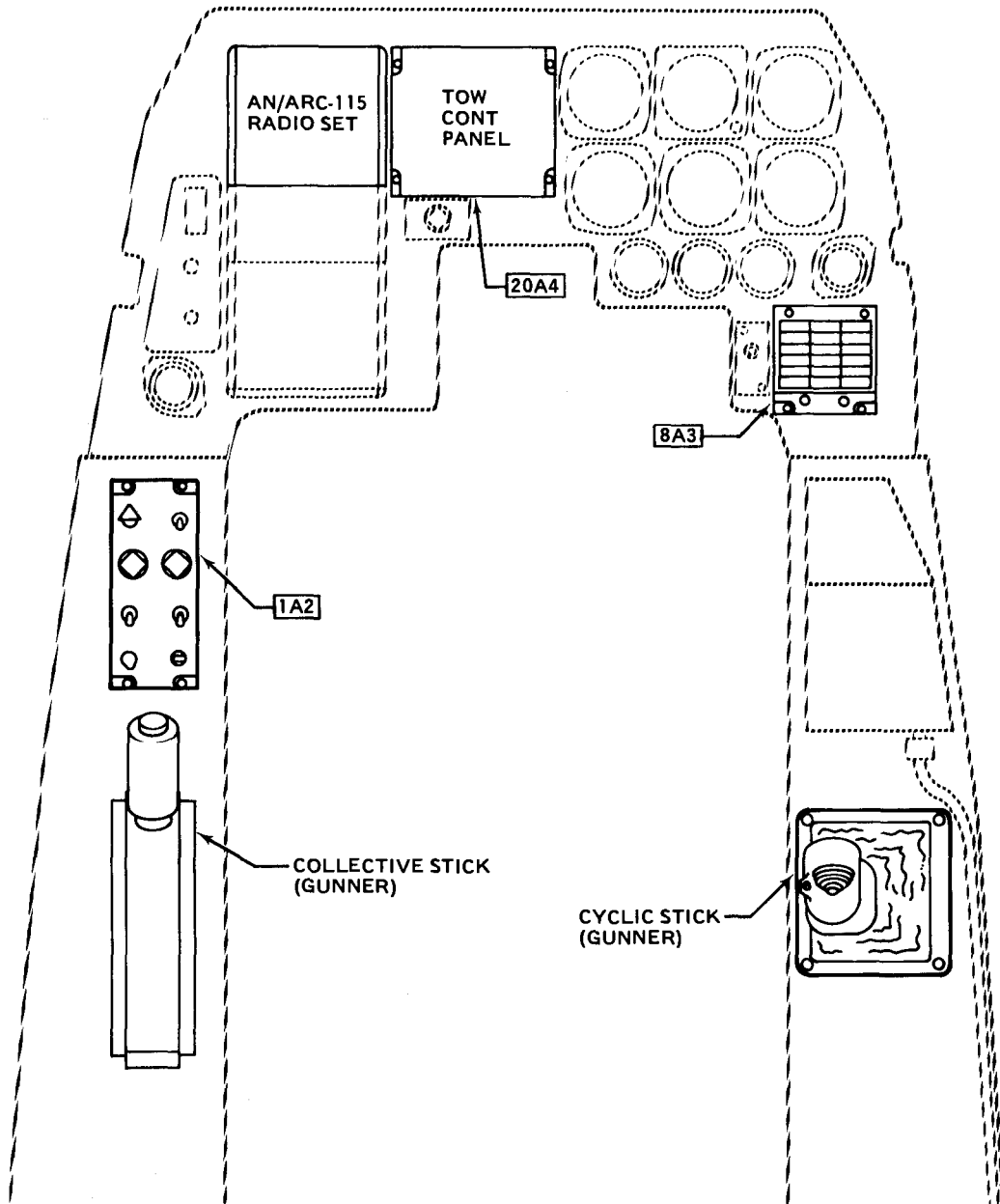

(CENTER VIEW)

209475-378-1A

CODE ITEM	DESCRIPTION
20A4	Panel, tow control
8A3	Panel, Gunners caution
1A2	Panel, gunners miscellaneous control

Figure 9-5. **P** Electrical Equipment Location - Gunners Section (Sheet 1 of 2)

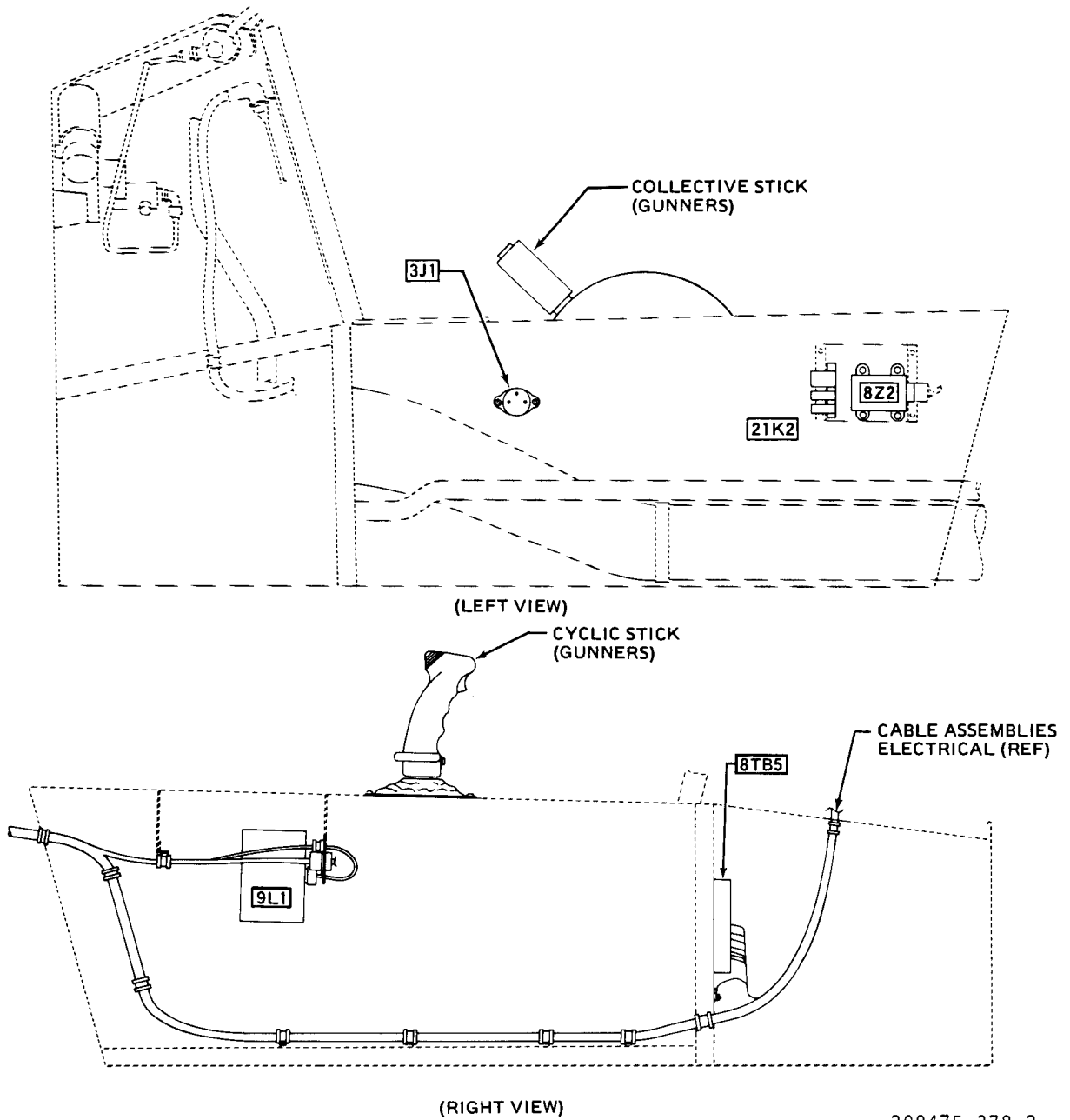

209475-378-2

CODE ITEM	DESCRIPTION
21K2	Relay, jettison control
3J1	Receptacle, engine vibration meter
8Z2	Unit, fire detection
8TB5	Terminal board, gunners lighting
9L1	Brake, anti-torque mag brake

Figure 9-5. **P** Electrical Equipment Location - Gunners Section (Sheet 2 of 2)

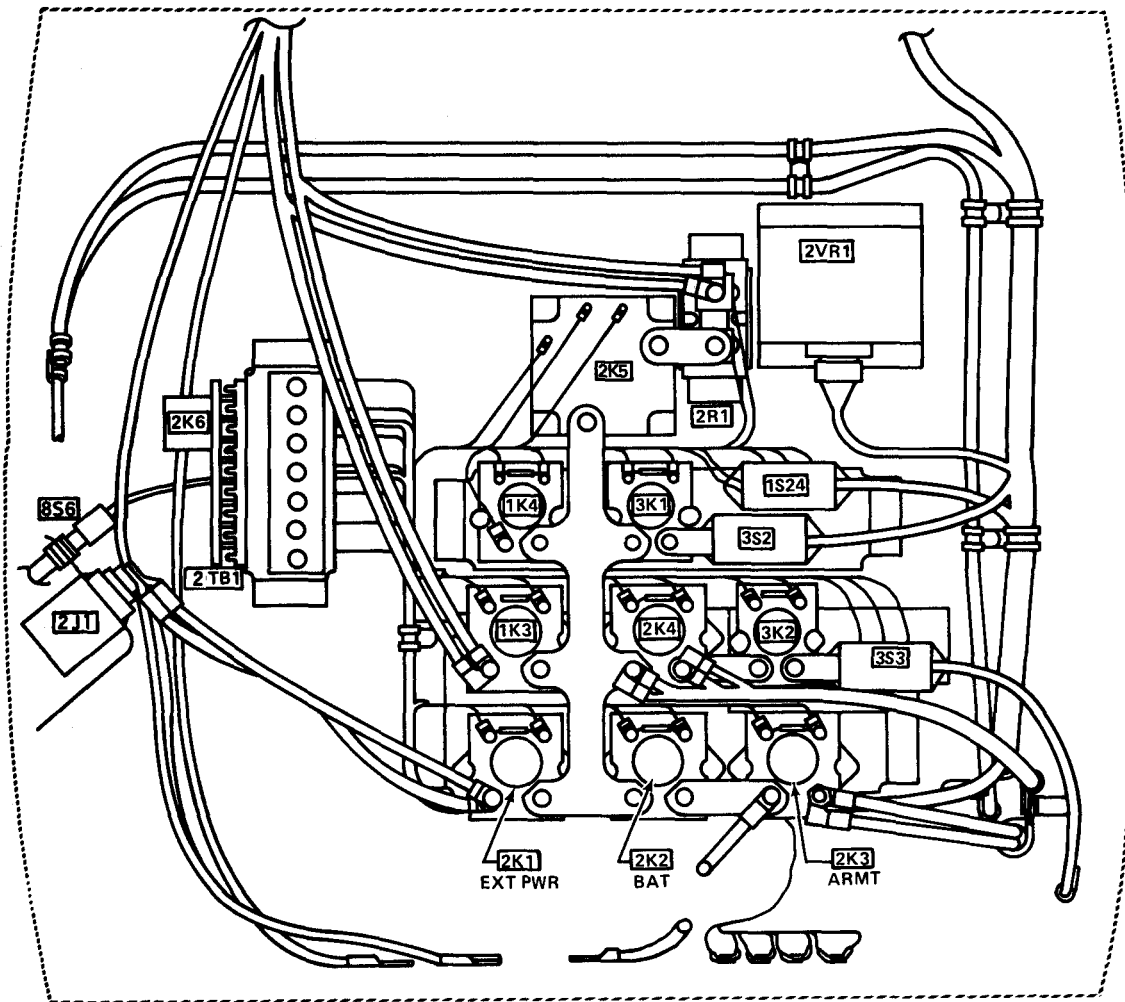

VIEW LOOKING FORWARD

209475-377-1B

CODE ITEM	DESCRIPTION
1K3	Relay, starter
1K4	Relay, emergency hydraulic power
1S24	Sensor, emergency hydraulic pump overload
2K1	Relay, external power
2K2	Relay, battery
2K3	Relay, turret power
2K4	Relay, nonessential bus
2K5	Relay, reverse current
2K6	Relay, generator field
2R1	Shunt
2VR1	Regulator, voltage
3K1	Relay, main inverter power
3K2	Relay, standby inverter Power
3S2	Switch, main inverter overload
3S3	Sensor, standby inverter overload
8S6	Switch, external power door
2TB1	Terminal board, external power
2J1	Receptacle, external Power

Figure 9-6. **P** Electrical Equipment Location — Aft Section (Sheet 1 of 3)



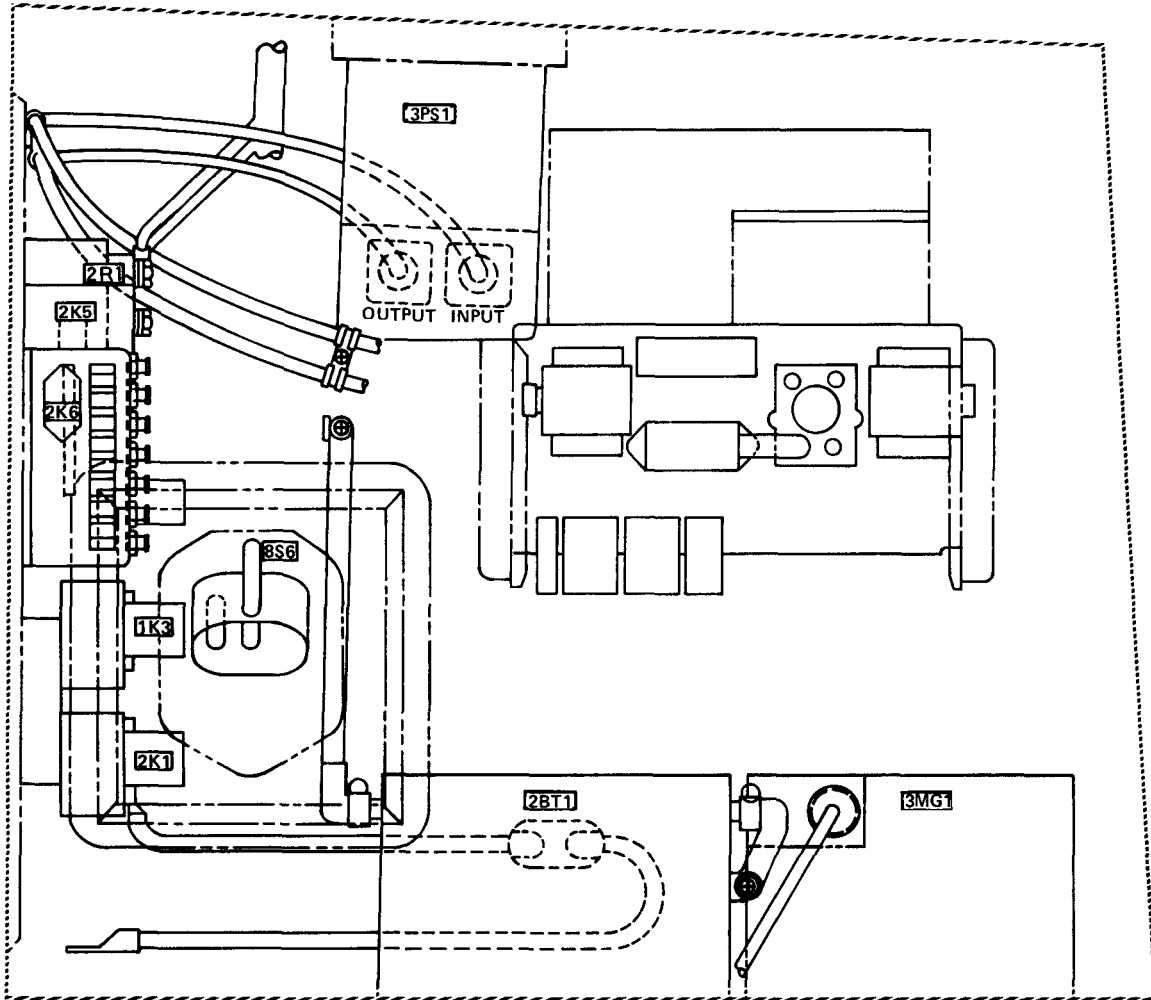

VIEW LOOKING INBOARD — LEFT SIDE

209475-377-2A

CODE ITEM	DESCRIPTION
1K3	Relay, starter
2BT1	Battery
2K1	Relay, external power
2K5	Relay, reverse current
2K6	Relay, generator field
2R1	Shunt
3MG1	Inverter, standby
3PS1	Inverter, main
8S6	Switch, external power door

Figure 9-6. **P** Electrical Equipment Location - Aft Section (Sheet 2 of 3)

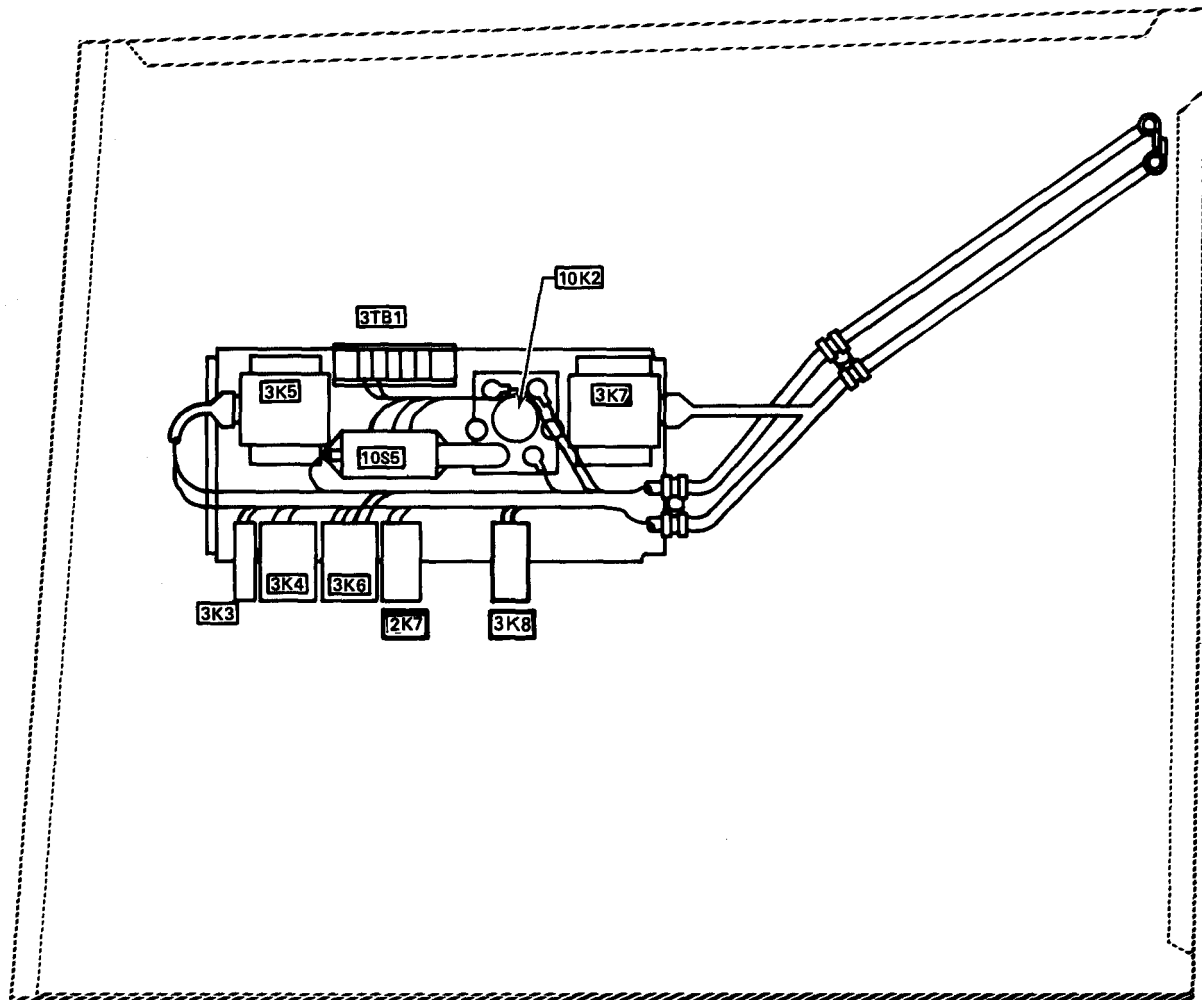

VIEW LOOKING OUTBOARD - LEFT SIDE

209475-377-3B

CODE ITEM	DESCRIPTION
2K7	Reley, bus control
3K3	Relay, AC power control
3K4	Relay, inverter three phase
3K5	Relay, main AC fail
3K6	Relay, inverter select
3K7	Relay, standby AC fail
3K8	Relay, main inverter light
3TB1	Terminal board, AC
10K2	Relay, heater control
10S5	Sensor, tow overload

Figure 9-6. **P** Electrical Equipment Location - Aft Section (Sheet 3 of 3)

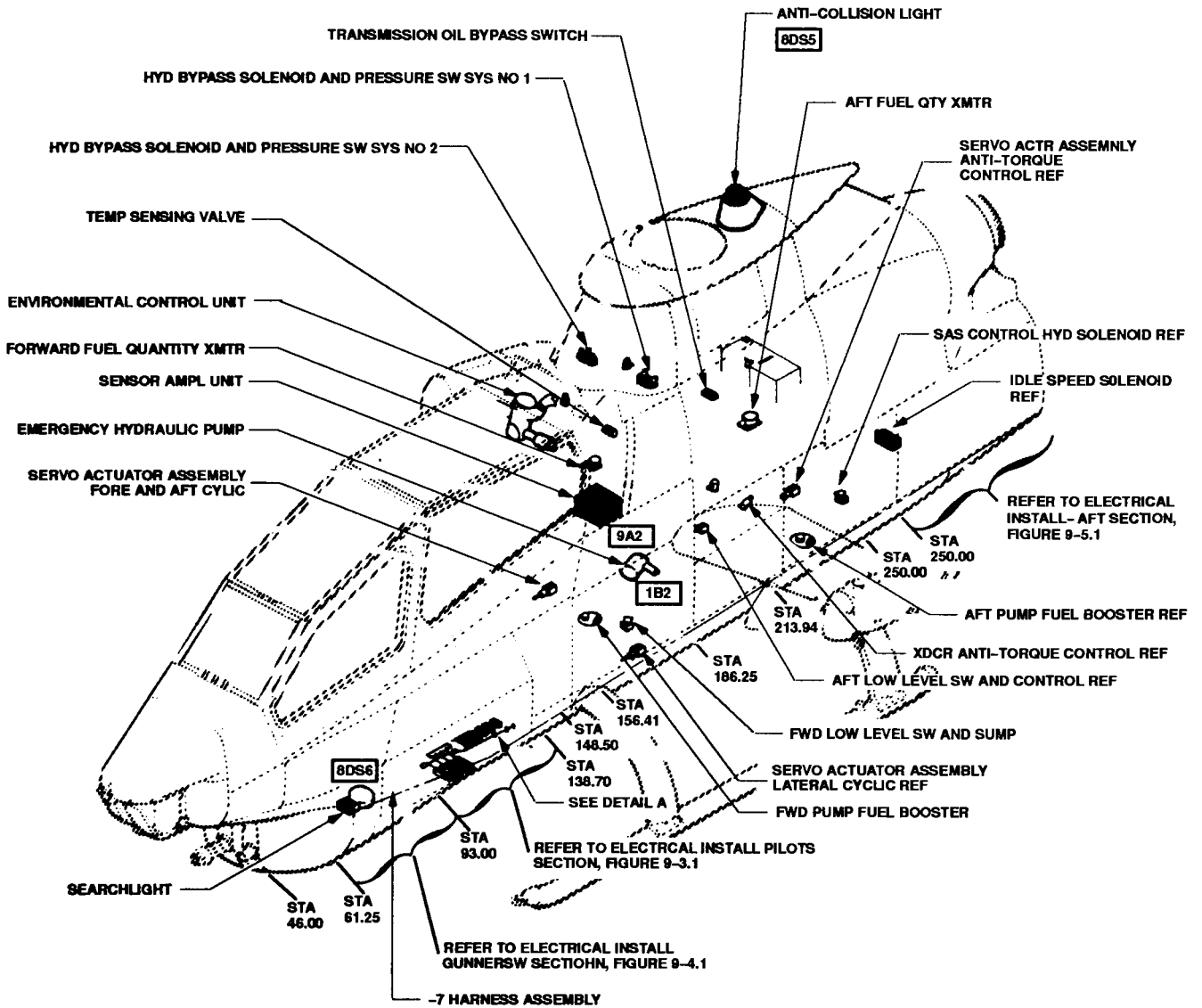
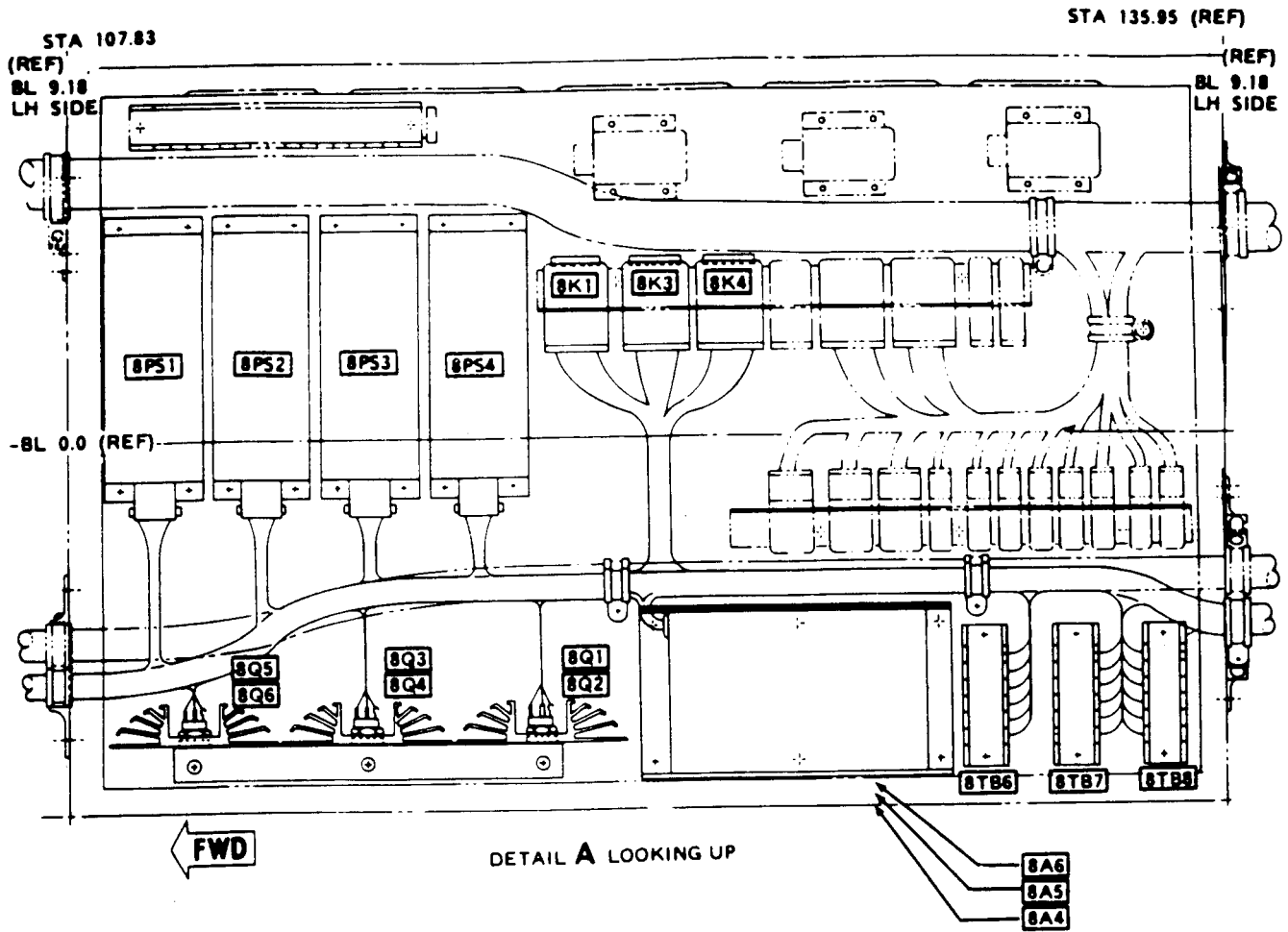

Figure 9-7. **E** Electrical Equipment Location - Forward Section (Sheet 1 of 2).



CODE ITEM	DESCRIPTION
8A4	PC Board -- NVG
8A5	PC Board -- NVG
8A6	PC Board -- NVG
8K1	Relay -- Gunner NVG
8K3	Relay -- Pilot NVG
8K4	Relay -- Pilot NVG
8PS1	Power Supply - Gunner Instrument Light
8PS2	Power Supply - Pilot Tactical Light
8PS3	Power Supply - Pilot Flight Instrument Light
8PS4	Power Supply - Pilot Engine Instrument Light

CODE ITEM	DESCRIPTION
8Q1	Transistor -- NVG
8Q2	Transistor -- NVG
8Q3	Transistor -- NVG
8Q4	Transistor -- NVG
8Q5	Transistor -- NVG
8Q6	Transistor -- NVG
8TB6	Terminal Board - Pilot NVG Lighting
8TB7	Terminal Board - Pilot NVG Lighting
8TB8	Terminal Board - Gunner NVG Lighting

Figure 9-7. **E** Electrical Equipment Location - Forward Section (Sheet 2 of 2)

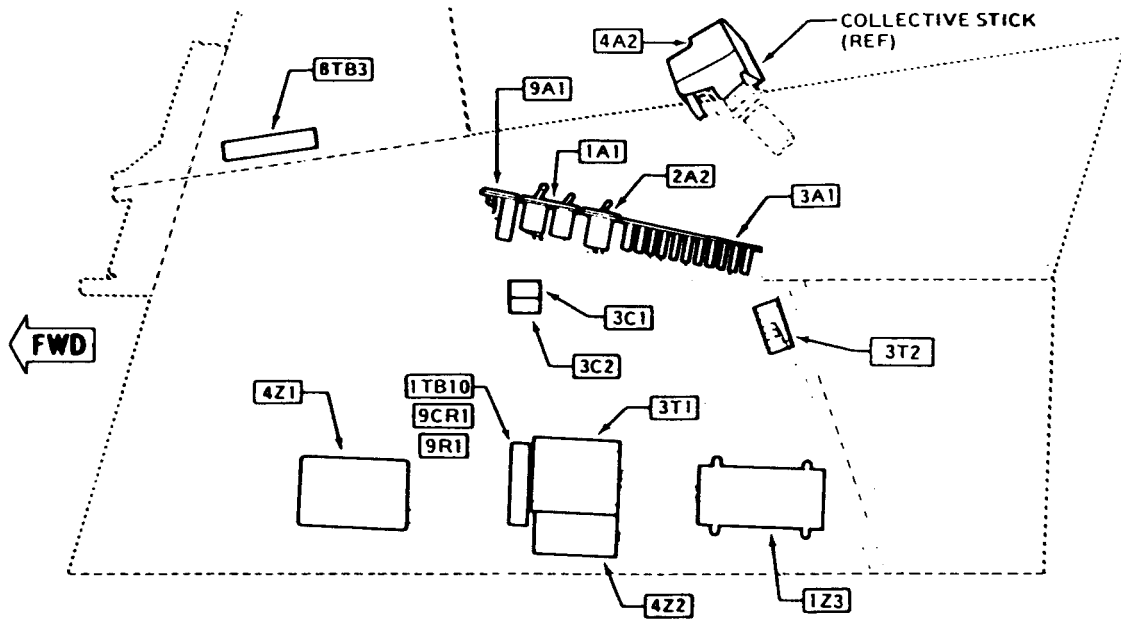

VIEW LOOKING INBOARD (LEFT SIDE)

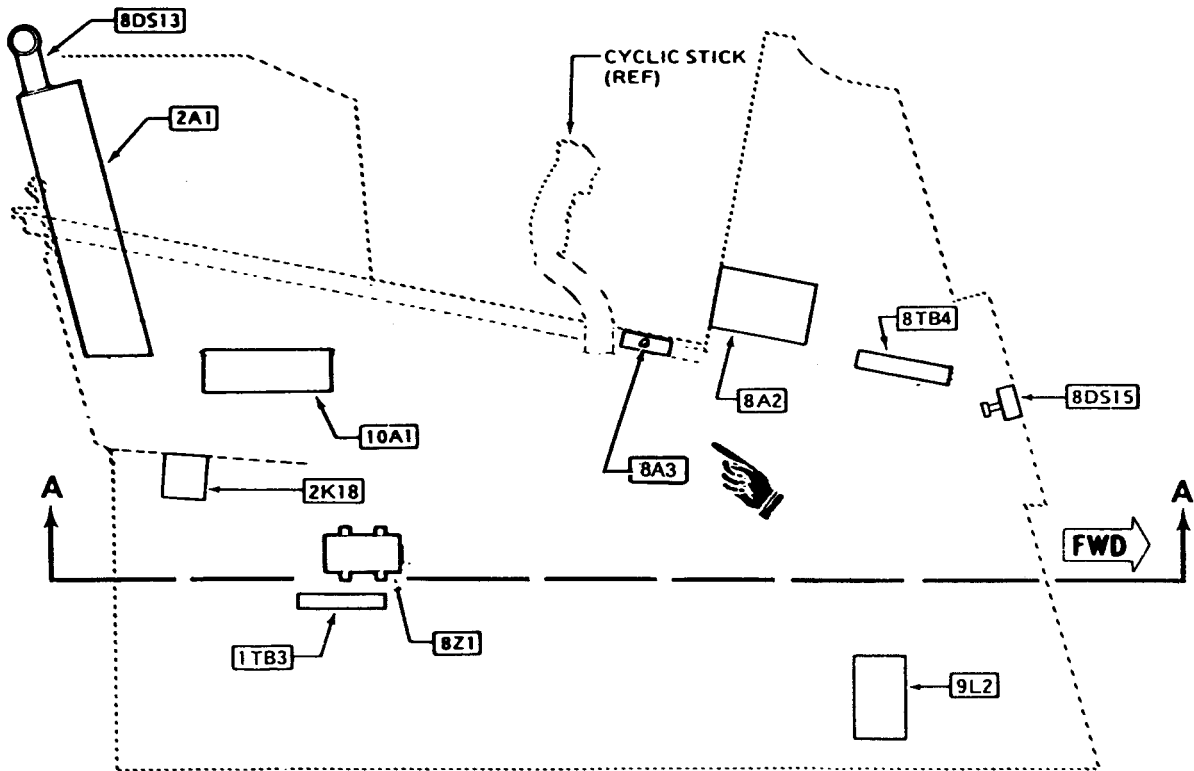

VIEW LOOKING INBOARD (RIGHT SIDE)

209475-441-1B

Figure 9-8. ■ Electrical Equipment Location - Pilot Section (Sheet 1 of 3)

Change 20 9-15

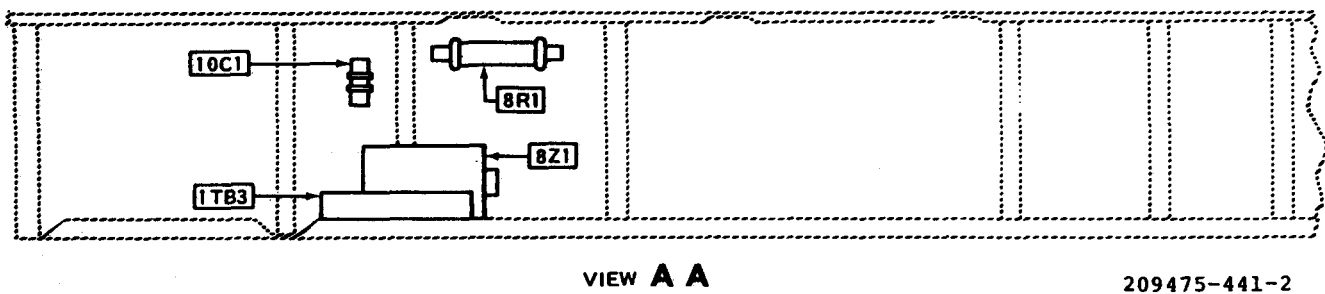
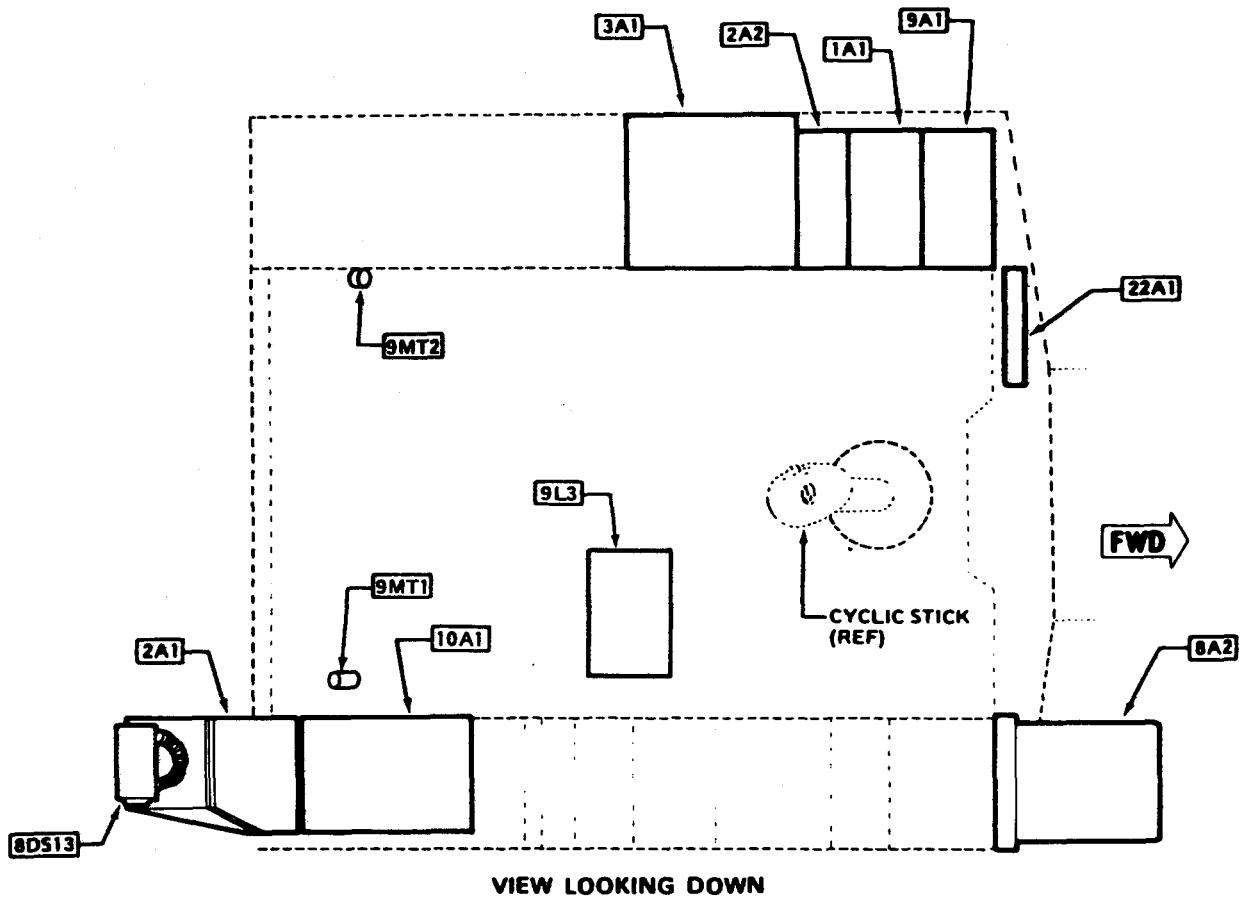

209475-441-2

Figure 9-8. **E** Electrical Equipment Location - Pilot Section (Sheet 2 of 3)

CODE ITEM	DESCRIPTION	CODE ITEM	DESCRIPTION
1A1	Panel, pilot engine control	8A3	Power module, ODDS
1TB3	Terminal board, engine instrument junction	8DS13	Light, pilot cockpit
1TB10	Terminal board, attitude indicator	8DS15	Light, gunner cockpit
1Z3	Detector, RPM	8R1	Resistor, navigation light
2A1	Panel, DC circuit breaker	8TB3	Terminal board, pilot instrument ground
2A2	Panel, pilot electrical control	8TB4	Terminal board. lighting/caution
2K18	Relay, SCAS	8Z1	Flasher, navigation light
3A1	Panel, AC/armament circuit breaker	9CR1	Diode, arc suppressor
3C1	Capacitor, power factor correction	9A1	Panel. SCAS control
3C2	Capacitor, power factor correction	9L2	Brake, lateral magnetic
3T1	Transformer, reference	9L3	Brake, fore/aft magnetic
3T2	Transformer, 115/28 VAC	9MT1	Motion transducer, pitch
4A2	Stick, pilot collective	9MT2	Motion transducer. roll
4Z1	Gyro, attitude	9R 1	Resistor, rate gyro
4Z2	Transmitter, rate gyro	10A1	Panel, pilot lighting/ECS
8A2	Panel, pilot caution	10C1	Capacitor, radio blower
		22A1	Panel, pilot miscellaneous

Figure 9-8. **E** Electrical Equipment Location - Pilot Section (Sheet 3 of 3)

**WARNING**

**Cleaning solvent is flammable and toxic. Provide adequate ventilation. Avoid prolonged breathing of solvent vapors and contact with skin or eyes.**

b. Remove grease, fungus, and ground-in dirt from the equipment cases and mountings; use a cloth dampened (not wet) with approved dry cleaning solvent (C112).

c. Before performing operational procedures on an electrical system, visually inspect that the installation is free of DEFECTS or DAMAGE. If any of the following conditions exist on the affected components or equipment, make necessary repairs (using standard practice) or replace.

d. The term DEFECT primarily includes the following conditions:

- (1) Connectors with corroded or bent pins.
- (2) Connectors with broken safety wire.
- (3) Frayed or broken insulation on conductors or interconnecting cabling.

(4) Faulty circuit breakers (will not remain closed when pressed) serving normal loads.

(5) Switches (rotary, sliding, tumbler, push-pull types) with loose mounting, weak position detents, and intermittent circuit connection.

(6) Panels with poor legibility of switch and selector setting markings and lighting.

(7) Loose knobs on control panels.

(8) Burned panel lights.

(9) Faulty (cracked, corroded, intermittent) or loose connectors and mounting.

(10) Burned, discolored, corroded, cracked, and broken components (diodes, resistors, capacitors, inductors, transistors, relays, etc.).

(11) Relays (dented, cracked, or corroded connectors) loose in receptacle or mounting, intermittent when lightly tapped with hand or small insulated object.

(12) Loose terminal boards and faulty mounted components (components that are cracked, dented, chipped, discolored from overload or open circuit including resistor, diodes, and condensers).

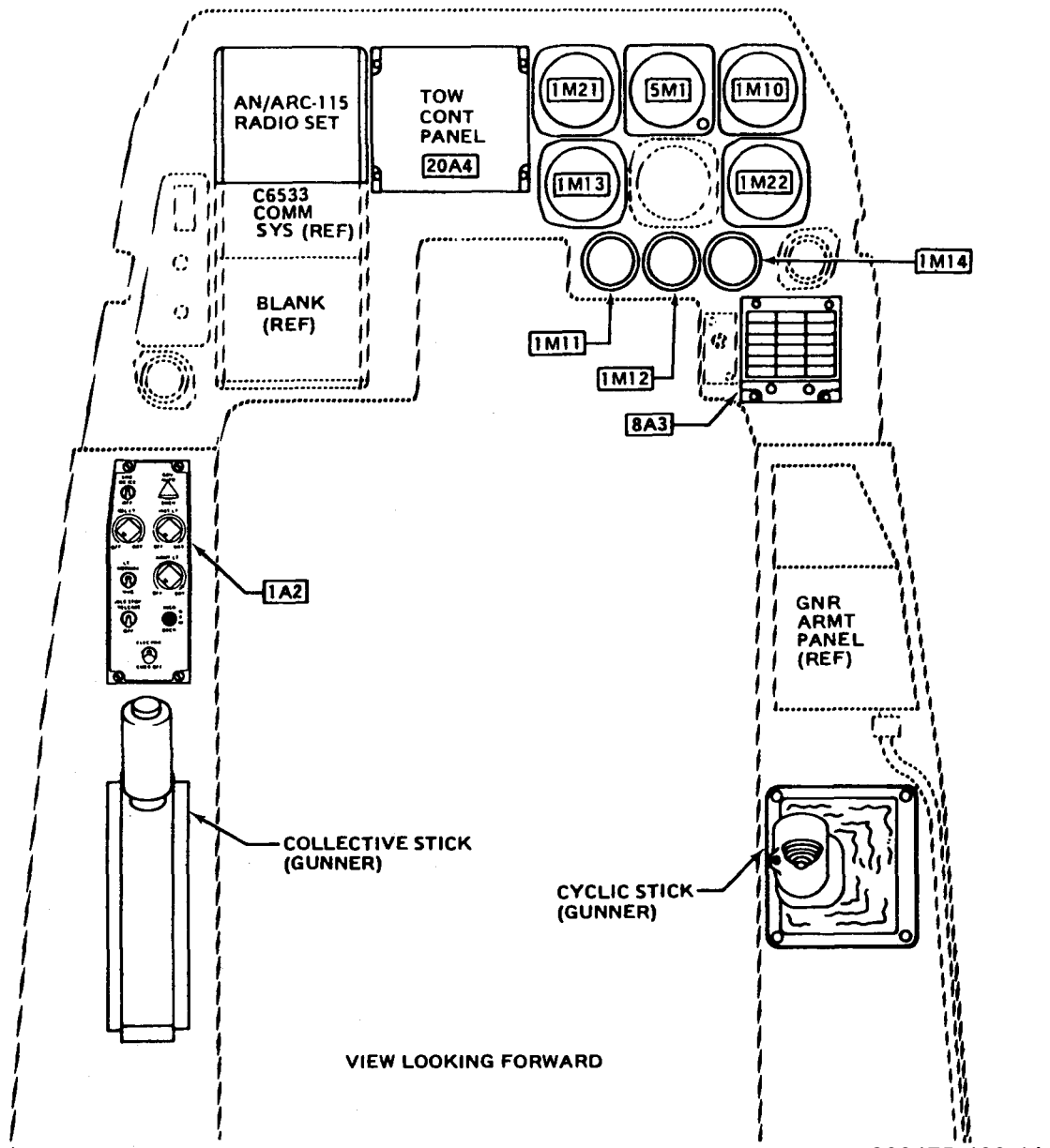

CODE ITEM	DESCRIPTION
1A2	Panel, gunner miscellaneous control
1M10	Indicator, altimeter
1M11	Indicator, gunner turbine gas temperature
1M12	Indicator, gas producer
1M13	Indicator, dual tachometer
1M14	Indicator, torque
1M21	Indicator, gunner airspeed
1M22	Indicator, gunner vertical speed
5M1	Indicator, gunner attitude
20A4	Panel, TOW control
8A3	Panel, gunners caution

209475-439-1A

Figure 9-9. **E** Electrical Equipment Location - Gunner Section (Sheet 1 of 2)



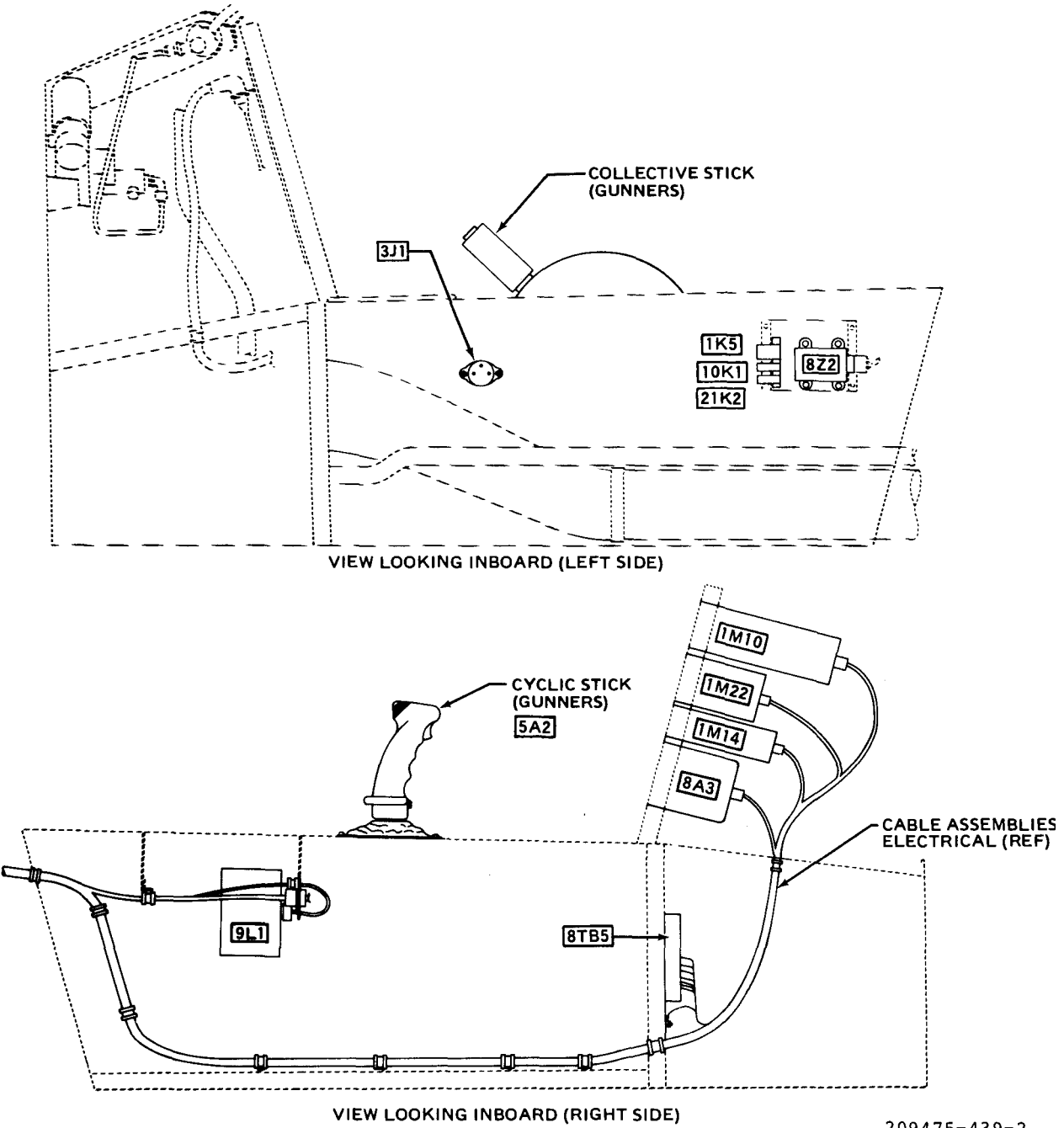

209475-439-2

CODE ITEM	DESCRIPTION	CODE ITEM	DESCRIPTION
1K5	Relay, emergency hydraulic control	8A3	Panel, gunner caution
1M10	Indicator, altimeter	8Z2	Flasher, navigation light
1M14	Indicator, torque	9L1	Brake, anti-torque magnetic
1M22	Indicator, vertical speed - gunner	10K1	Relay, heater control
3J1	Receptacle, engine vibration meter	21K2	Relay, jettison control
5A2	Cyclic stick gunner	8TB5	Terminal board, gunners lighting

Figure 9-9. **E** Electrical Equipment Location - Gunner Section (Sheet 2 of 2)

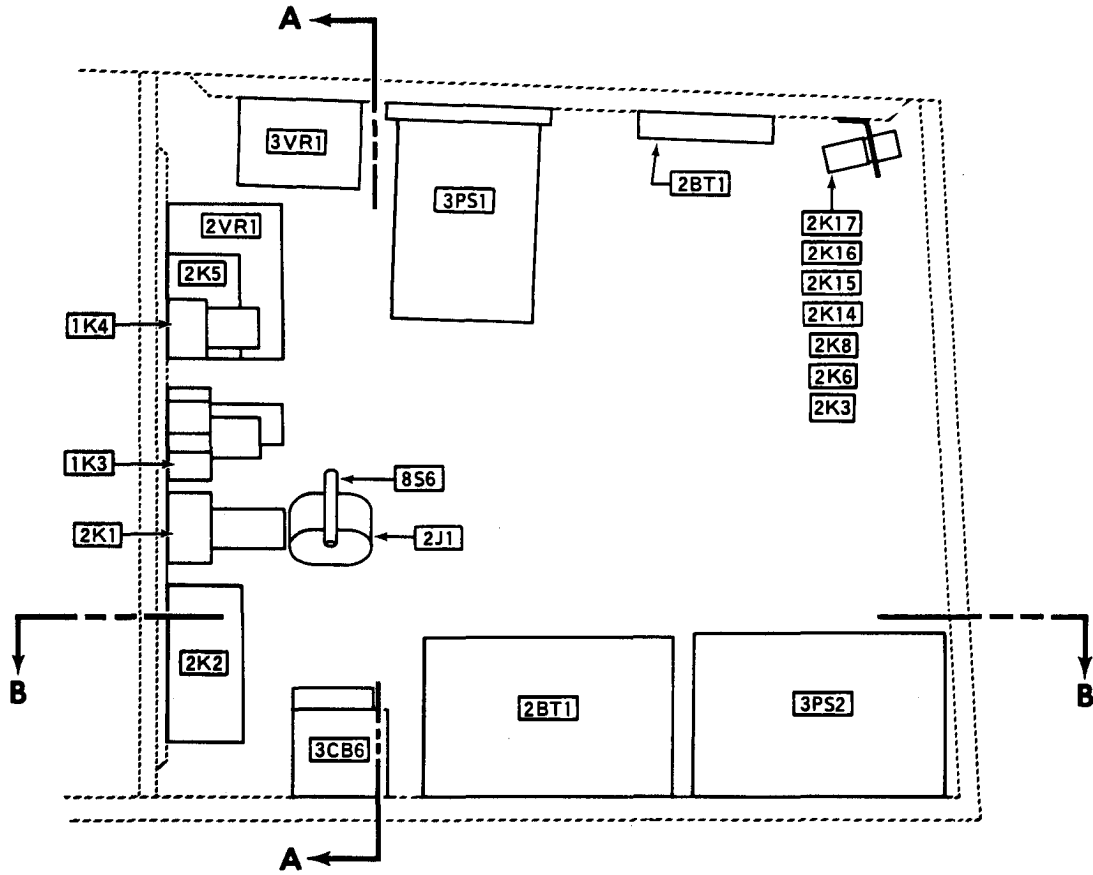

VIEW LOOKING INBOARD (L.H. SIDE)

209475-440-1B

CODE ITEM	DESCRIPTION
1K3	Relay, starter
1K4	Relay, emergency hydraulic pump
2BT1	Battery
2J1	Receptacle, external power
2K1	Relay, external power
2K2	Relay, battery
2K3	Relay, battery control
2K6	Relay, reverse current
2K6	Relay, generator field
2K8	Relay, battery control
2K14	Relay, reverse current control
2K15	Relay, transformer rectifier unit (TRU) control
2K16	Relay, external power
2K17	Relay, armament control
2TB1	Terminal board, relay interface
2VR1	Regulator, voltage
3CB6	Circuit breaker, transformer rectifier
3PS1	Inverter
3PS2	Unit, transformer rectifier
3VR1	Control, alternator
8S6	Switch, external power door

Figure 9-10. **E** Electrical Equipment Location - Aft Section (Sheet 1 of 3)

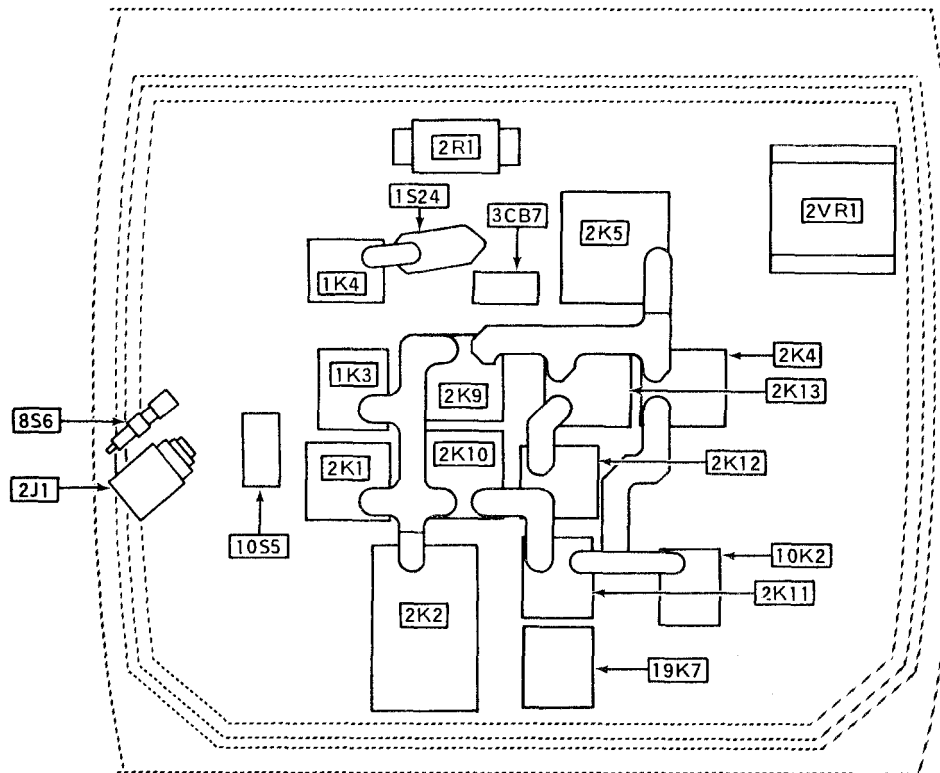

VIEW A-A

VIEW LOOKING FWD BHD 268.25

209475-440-2

CODE ITEM	DESCRIPTION
1K3	Relay, starter
1K4	Relay, emergency hydraulic pump
1S24	Switch, emergency hydraulic pump overload
2J1	Receptacle, external power
2K1	Relay, external power
2K2	Relay, battery
2K4	Relay, nonessential
2K5	Relay, reverse current
2K9	Relay, essential
2K10	Relay, transformer rectifier unit (TRU) essential
2K11	Relay, transformer rectifier unit (TRU) nonessential
2K12	Relay, transformer rectifier unit (TRU) armament
2K13	Relay, armament
2R1	Shunt
2VR1	Regulator, voltage
3CB7	Circuit breaker, inverter
8S6	Switch, external power door
10K2	Relay, tow blower
10S5	Sensor, tow blower overload
19K7	Relay, turret power

Figure 9-10. **E** Electrical Equipment Location - Aft Section (Sheet 2 of 3)

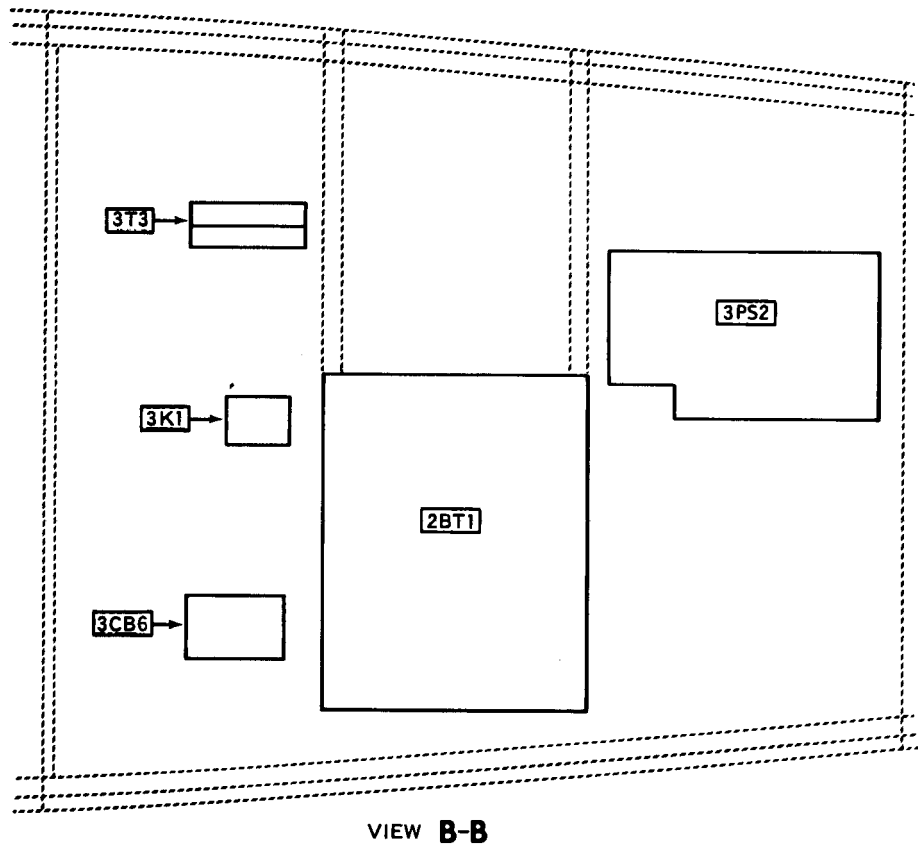

209475-440-3A

CODE ITEM	DESCRIPTION
2BT1	Battery
3CB6	Circuit breaker, transformer rectifier
3K1	Relay, source
3PS2	Unit, transformer rectifier
3T3	Transformer, current

Figure 9-10. **E** Electrical Equipment Location - Aft Section (Sheet 3 of 3)

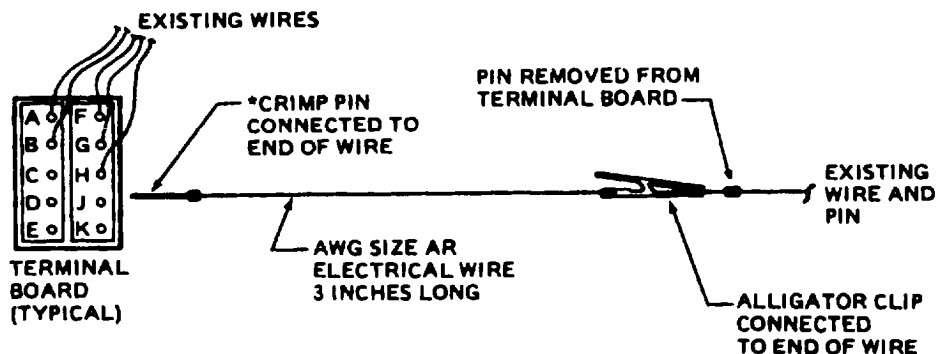

**\*PIN Contact Part Numbers**

**MIL**

- M39029/1-16-22
- M39029/1-16-20
- M39029/1-14-16
- M39029/1-12-12

**MATRIX**

- 5000-027-22
- 5000-027-20
- 5000-027-16
- 5000-027-12

214077-134

Figure 9-11. Environmental Connector Test Adapter

The term DAMAGE primarily includes the following conditions:

(1) Broken connectors, terminal boards, and conductors.

(2) Corroded, dented, cracked, or broken equipment and/or mountings.

f. Coat all exposed electrical and electronic equipment with either MIL-C-16173 (C43.1) or MIL-C-85054 (C44.3).

**9-10. VOLTAGE MEASUREMENTS.**

**NOTE**

Ensure multimeter (T2) or equivalent is in normal operating condition. Select applicable voltage range for the most accurate reading to match the value given on the respective electrical system wiring diagrams

a. Perform voltage measurements (ac and dc) where applicable if equipment and airframe component(s) of the respective system malfunctions while conducting the operational procedures.

b. Check voltage of respective systems at test points and terminal boards on the airframe in accordance with system wiring diagrams.

c. Check the primary voltage input on load side of respective circuit breaker in accordance with system wiring diagrams.

**9-11. CONTINUITY TRACE.**

Conduct resistance measurement (continuity trace) using resistance selection on multimeter (T77), or equivalent, with primary electrical power removed from the helicopter. Conduct continuity trace for localization of INVISIBLE defects of connectors, conductors, terminal boards, diodes, resistors,

capacitors, transistors, relays, inductors, switches, selectors, and equipments. For a logical approach to a rapid analysis of faulty airframe conductors and components within an electrical system, that cannot be determined by visual inspection, follow the suggested sequential steps below:

**NOTE**

If respective system does not perform normally during operational test procedures, remove dc power from helicopter and conduct continuity trace to suspected components and/or equipment within the circuitry.

Under certain conditions of component and/or equipment malfunction it may be necessary to make voltage measurements and/or continuity trace combinations to "pinpoint" the trouble.

- a. Analyze the respective system wiring diagram for airframe interunit conductor paths (single, paralleled, and series); consider resistors, diodes and relay holding coils, etc., which may alter the sum total resistance of conductor paths.

**NOTE**

On multimeter, check that meter movement is free and that ohms selection and ranges will zero with ohms adjust knob.

**NOTE**

When performing resistance measurements, select the range to give the most accurate reading of the path (conductor, resistor, diode, relay holding coil, transistor, and capacitor) selected from the electrical system wiring diagram.

- b. Check continuity and resistance of individual conductors within the respective interconnecting cabling.
- c. Check continuity and resistance of individual conductors for abnormal conductivity with adjacent conductors, shielding and common ground.
- d. Check resistors for normal value.
- e. Check diodes for front-to-back ratio.

- f. Check capacitors for retention factor (deflection and rate of return of multimeter pointer).

**9-12. GENERAL REPAIR TECHNIQUES.**



Ensure that the battery is disconnected before attempting any removal or replacement procedures.

- a. Repair of the electrical configuration, with certain exceptions, consists of removal of defective components and replacement of these components with known serviceable components from maintenance stocks. When removal and replacement of an electrical component or other repair procedures require performing repairs on the airframe, helicopter engine controls, or other items that directly affect the flight of the helicopter, the repair effort must be performed by or coordinated with the helicopter crew chief.

- b. When a troubleshooting procedure indicates that a component is defective, follow the applicable removal procedures in this section. Replace the removed component with a known serviceable equivalent component. After the component has been replaced, install lockwire (C137), as required, on the mounting hardware and electrical connectors.

**9-13. OPERATIONAL CHECKS - ELECTRICAL.**

Utilize system wiring diagrams in accomplishing functional tests of electrical circuits and components. Conduct tests after installation, repair, or replacement of equipment.

**9-14. COMMON ELECTRICAL COMPONENTS.**

**9-15. DESCRIPTION - COMMON ELECTRICAL COMPONENTS.**

Common electrical components consist of miscellaneous electrical components, circuit breakers, and control panels.

## 9-16. MISCELLANEOUS ELECTRICAL COMPONENTS.

### 9-17. DESCRIPTION - MISCELLANEOUS ELECTRICAL COMPONENTS.

Miscellaneous electrical components included in this category are capacitors, conduits, connectors, diodes, leads, panel lights, plugs, receptacles, relays, rheostats, shock mounts, shunts, switches, and wiring.

### 9-18. CLEANING - MISCELLANEOUS ELECTRICAL COMPONENTS (GENERAL).

a. Remove moisture, dust, and loose dirt with a clean, soft cloth.

#### **WARNING**

**Cleaning solvent is flammable and toxic. Provide adequate ventilation. Avoid prolonged breathing of solvent vapors and contact with skin or eyes.**

b. Remove grease, fungus, and ground-in dirt from the equipment cases and mountings; use a cloth dampened (not wet) with dry cleaning solvent (C112).

### 9-19. INSPECTION - MISCELLANEOUS ELECTRICAL COMPONENTS.

a. Inspect rheostats for security, corrosion, burned element, damaged wiper, cracks, and correct resistance.

b. Inspect switches for weak detents, security, corrosion, faulty operation, and continuity in ON and infinity in OFF position.

c. Inspect plugs, connectors and receptacles for security, contact corrosion, damaged contacts, broken wires, faulty contacts, insert cracks, and faulty insulation.

d. Inspect leads and wiring for loose terminals, chafing, corrosion or deteriorated condition, faulty or damaged insulation, excessive mechanical stress, broken strands, damaged shielding, shorted shielding, routing and mounting conditions.

e. Inspect conduits for security, surface damage, cracks, dents, corrosion, and deterioration.

f. Inspect shunts and bus bars for corrosion, security, deep scratches, physical damage, deformity, and discoloration (indicating excessive overloading).

g. Inspect shock mounts for binding, compression, retention, security, cracks, distortion, and corroded bonding.

h. Inspect relays for loose connections, damaged or broken contact pins or terminals, damage to case or insulation between contact pins, and evidence of corrosion, pits, or discoloration (indicating arcing due to loose connections, internal shorting, or excessive overload).

j. Inspect panel lights for faulty bulbs, security, and corrosion.

k. Visually check capacitors for loose connections, security of mounting, seeping dielectric, and apparent damage.

l. Visually check diodes for loose connection and broken leads. Check suspected faulty diode front to back conductivity ratio with standard ohmmeter.

m. Visually check transistor mount for security. Check suspected faulty transistor by voltmeter.

n. Inspect NVG flip filters for security, proper operation and cracked or broken lenses.

### 9-20. REMOVAL - MISCELLANEOUS ELECTRICAL COMPONENTS.

#### **CAUTION**

**Before removing or adjusting any electrical component, disconnect battery to prevent damage to equipment.**

a. Remove attaching hardware, clamps, connectors or conductors; identify connectors and/or conductors.

b. Remove component.

### 9-21. REPAIR - MISCELLANEOUS ELECTRICAL COMPONENTS.

a. Tighten loose terminal connectors, mounting and attachments of electrical components.

b. Replace miscellaneous electrical components that fail to meet inspection requirements.

**9-22. INSTALLATION - MISCELLANEOUS ELECTRICAL COMPONENTS.**

- a. Install component and secure with attaching hardware or clamps.
- b. Attach identified terminals and/or connectors.

**9-23. CIRCUIT BREAKERS.**

**9-24. DESCRIPTION - CIRCUIT BREAKERS.**

The circuit breakers are mounted in the AC/ARMT and dc circuit breaker panels in the pilot side console. Circuits can be opened and closed by operating these trip-free, push-pull circuit breakers. (Some armament circuit breakers may be toggle circuit breakers.)

**9-25. CLEANING - CIRCUIT BREAKERS.**

Clean circuit breakers in accordance with paragraph 9-18.

**9-26. INSPECTION - CIRCUIT BREAKERS.**

Inspect circuit breakers for reset retention, actuation for circuit power ON and power OFF, faulty operation, corrosion and security.

**9-27. REMOVAL - CIRCUIT BREAKERS.**

- a. Be sure all electrical power is OFF. Disconnect battery.
- b. Disconnect wiring to appropriate breaker and cover wire ends with electrical tape.
- c. Remove mounting hardware and lift breaker from panel assembly.

**9-28. REPAIR - CIRCUIT BREAKERS.**

- a. Repair is limited to tightening or properly installing any loose or improperly installed mounting hardware and connectors.
- b. Replace circuit breaker if any other inspection requirements are not met.

**9-29. INSTALLATION - CIRCUIT BREAKERS.**

a. Position breaker in panel assembly and install mounting hardware.

b. Remove cover from wire ends and connect to breaker.

**9-30. CONTROL PANELS.**

**9-31. DESCRIPTION - CONTROL PANELS.**

The control panels are mounted in the consoles at the pilot and gunner stations.

**9-32. CLEANING - CONTROL PANELS.**

Clean control panels in accordance with paragraph 9-18.

**9-33. INSPECTION - CONTROL PANELS.**

Visually inspect for scratches, chipped edges, faulty edge light panels and bulbs, broken edge light panels, damaged or faulty switches, loose or damaged wiring and connectors, and broken or missing mounting fasteners.

**9-34. REMOVAL - CONTROL PANELS.**

**NOTE**

The removal procedures for all electrical control panels are relatively the same. A single removal procedure may be used for any electrical control panel.

- a. Ensure all electrical power is OFF.
- b. Disengage fasteners holding panel mounting.
- c. Carefully lift panel from mount.
- d. Disconnect electrical connector(s).

**9-35. REPAIR - CONTROL PANELS.**

a. Repair any scratches or chipped edge light panels.

**NOTE**

Failure of integrally lit panels to illuminate will require replacement of control panel.



b. Replace control panel if any other inspection requirements are not met.

b. Position panel in mount; being careful not to damage wiring. Engage fasteners.

### 9-36. INSTALLATION - CONTROL PANELS.

a. Connect electrical connector(s).

c. Apply power and check components for proper operation.

## SECTION II. DIRECT CURRENT POWER DISTRIBUTION SYSTEM

### 9-37. DIRECT CURRENT POWER DISTRIBUTION SYSTEM.

operation. (TRU requires 3 phase, 115 Vac input power from alternator).

### 9-38. DESCRIPTION - DIRECT CURRENT POWER DISTRIBUTION SYSTEM.

a. **P** The direct current power distribution system provides all basic power for operation of electrical components installed in the helicopter and consists of the battery; external power, generator, and dc bus systems.

The three distribution buses are the essential bus (ESS BUS), the non essential bus (NON ESS BUS), and the armament bus (ARMT BUS). BUS interconnect logic circuits control power transfer from the PWR XFR BUS and TRU BUS to the three distribution buses, as required, depending on crew station control switch settings and power source operation status.

b. **E M** The direct current power system provides the direct current (dc) electrical power required for operation of the electrical equipment installed in the helicopter. It also provides for utilizing external power for engine starting and checkout of electrical, avionics and armament systems.

Any distribution bus can be supplied with power from any power source, depending on operating mode, except that the battery alone cannot supply the ARMT BUS. Interlock logic prevents incompatible power source interconnection. A battery (2BT1) and provisions for using external power connect directly to the essential load distribution bus. The interconnect logic circuits also control application of power from these sources as required for engine starting and ground checkout operations. Battery charging from any other power source is possible when proper conditions for battery charging exist, Pilot station controls are battery switch (2S1), generator switch (2S3), non-essential bus switch (2S2), master arm switch (19S12), and gunner station pilot override armament switch (19S7). The electrical power emergency switch allows gunner to shut off all electrical power to the helicopter in an emergency situation. The pilot override armament switch permits gunner to energize the ARMT BUS and fire weapons in case of pilot incapacitation in certain modes of operation.

The direct current power system consists of the following:

- (a) Three installed power sources
- (b) One power transfer bus and one TRU bus
- (c) Three distribution buses
- (d) Interconnecting relays
- (e) Interconnect logic relays
- (f) Crew station control switches
- (g) External power provisions

The three power sources are a starter-generator (1MG1), a transformer-rectifier unit (TRU) (3PS2), and a battery (2BT1). The starter-generator supplies power directly to the PWR XFR BUS. The TRU supplies power directly to the TRU BUS when alternator is in

Normal operation: In flight, both the starter-generator and the TRU are energized. If the armament system is off, starter-generator power is applied through the PWR XFR BUS to the ESS BUS and TRU power is applied through the TRU BUS to the NON-ESS BUS. When the armament system is energized,

starter-generator power is applied through the PWR XFR BUS to the ARMT BUS and ESS BUS. TRU power is applied through the TRU BUS to the NON-ESS BUS.

In-flight or ground run without external power, battery power is applied to the ESS BUS with battery switch in START or RUN. The NON-ESS BUS may be energized by placing the NON-ESS BUS switch in MANUAL position.

With EXT PWR applied, ESS and NON/ESS buses are energized and the ARMT BUS may be energized by placing the master arm switch in STBY or ARM or by placing the pilot override switch in PLT ORIDE.

**Operation with inoperable power source:** With the TRU inoperable and with the armament system off, the starter-generator supplies power through the PWR XFR BUS to both the ESS BUS and the NON-ESS BUS. With the armament system on, the starter-generator supplies the NON-ESS BUS and ARMT BUS. With the starter-generator inoperable and with the armament system off, the TRU supplies the ESS BUS and NON-ESS BUS through the TRU BUS. With the armament system on, the TRU supplies the ESS BUS, NON-ESS BUS and the ARMT BUS through the TRU BUS.

With both TRU (or ALT) and starter-generator inoperable, the BAT supplies the ESS BUS and, at the pilot option, the NON-ESS BUS.

## 9-39. BATTERY SYSTEM.

### 9-40. DESCRIPTION - BATTERY SYSTEM.

a. q The battery system is comprised of the battery (2BT1), battery relay (2K2), BAT switch (2S1) and utilizes the ELEC PWR position of the gunners ELEC PWR - EMER OFF selector switch (2S4). The battery weapons power system is comprised of the WPNS FIRE circuit breaker (19CB3), gun clearing relay (19K1), and turret power relay (2K3).

(1) The battery circuit is actuated by placing the pilot BAT switch to the ON position and the gunner ELEC PWR - EMER OFF selector switch to the ELEC PWR position (the ELEC PWR - EMER OFF selector switch is normally locked in the ELEC PWR position). Battery relay (2K2) is energized through the contacts of gun clearing relay (19K1) and battery power is transferred through the contacts of battery relay (2K2) to the main and essential dc buses. The non-

essential bus relay (2K4) is energized when the NON-ESNTL BUS switch (2S2) on the pilot electrical power control panel is set to MANUAL and battery power is applied through the contacts of (2K4) to the non-essential bus. The volt/loadmeter (2M1) monitors the essential bus battery voltage when DC VM circuit breaker (2CB5) is closed. This voltage will be approximately 24 Vdc when the battery is reasonably well charged. After the battery has been used for engine starting and the starter-generator becomes operational, the volt/loadmeter will indicate high current (dependent upon state of charge of the battery). As the battery becomes recharged, the volt/loadmeter reading will decrease gradually until the battery becomes completely recharged. When battery is completely recharged, there will be no perceptible difference (5 amperes or less differential) in volt/loadmeter reading when BAT switch is moved from ON to OFF.

(2) Due to the high current demand of turret weapons, battery power is used to supply the left and right turret weapons speed controllers, and the battery is isolated from the main dc bus during turret firing. Gun clearing relay (19K1) is energized when cyclic stick trigger is depressed. This de-energizes (opens) battery relay (2K2), removing the battery from the main dc bus and energizes (closes) turret power relay (2K3), thereby energizing feeder wires which supply power to the turret weapons speed controllers for gun drive power. When the cyclic trigger is released, relay (19K1) remains energized for approximately one-half second (to allow for gun clearing), then opens. This action de-energizes (opens) relay (2K3) removing power from speed controllers; and energizes relay (2K2) reconnecting battery to the main dc bus for recharging.

b. **E M** The The battery system is comprised of the battery (2BT1), battery relay (2K2), BATTERY switch (2S1) ELEC PWR switch (2S4), battery relay (2K3) and SCAS relay (2K18). The battery system is actuated by placing the pilot BATTERY switch (2S1) to START position. This completes a ground circuit from the NEG terminal of the battery relay (2K2) through closed contacts of ELEC PWR EMER OFF switch (2S4). (The emergency power switch (2S4) is normally locked in the ELEC PWR position.) When the ground circuit is completed to the NEG terminal, the contacts of battery relay (2K2) close, connecting the battery (2BT1) to the 28 VDC ESS BUS. The battery will then provide power to the ESS BUS for emergency power or for checkout of equipment. If ESS BUS is energized by external power or from the

PWR XFR BUS or TRU BUS, charging of the battery will occur.

**9-41. FUNCTIONAL TEST – BATTERY SYSTEM.**

The following tests of the battery circuitry shall be performed using the installed 24 Vdc battery as a power source, or alternatively, an external 24 Vdc power source connected to the battery connector.

a. Before connecting power to battery circuitry, open all circuit breakers and place all switches to their open positions. Check that an open circuit exists between positive terminals of the battery quick-disconnect and ground.

b. Check all battery circuitry connections for tightness and correct polarity.

c. Connect the battery or external power source. Close DC circuit breakers in aft electrical compartment and on DC circuit breaker panel in pilots cockpit. Position ELEC PWR — EMER OFF switch (2S4) on gunners miscellaneous control panel, to EMER OFF

(switch toggle must be pulled out to actuate switch). Position **P** BAT **E** **M** BATTERY switch (2S1) on pilot electrical control panel; to **P** ON **E** **M** START. Check that voltmeter indicates no voltage.

d. Place gunner ELEC PWR — EMER OFF switch (2S4) to ELEC PWR. Check that voltmeter now indicates battery or external power source voltage.

e. Return **P** BAT **E** **M** BATTERY switch (2S1) to OFF. Check that voltmeter indicates no voltage.

**9-42. TROUBLESHOOTING — BATTERY SYSTEM.**

Use Table 9-1 and perform checks necessary to isolate trouble. Refer to paragraph F-9 in Appendix F for wiring diagrams.

In the following table, tripped circuit breakers are omitted from indications of trouble. Such trouble is usually easily detected and corrected. Broken wiring is always a probable cause of circuit malfunction or failure and has not been induced.

**NOTE**

Before you use this table, be sure you have performed all normal operational checks. If you have a malfunction which is not listed in this table, notify the next higher level of maintenance.

Table 9-1. Troubleshooting Battery System

CONDITION
TEST OR INSPECTION
CORRECTIVE ACTION
<p>1. Voltmeter indicates zero volts with DC VM circuit breaker closed, ELEC PWR — EMER OFF switch on gunner miscellaneous control panel to ELEC PWR position and <b>P</b> BAT <b>E</b> <b>M</b> BATTERY switch in <b>P</b> ON <b>E</b> <b>M</b> RUN position.</p> <p>STEP 1. With multimeter (T77), or equivalent, determine if voltage is present on 28 Vdc essential bus.</p> <p>If voltage is present on essential bus continue with Step 2. If voltage is not present continue with Step 4.</p> <p>STEP 2. Check for bus voltage on voltmeter side of DC VM circuit breaker.</p> <p>Replace circuit breaker if defective (paragraph 9-23).</p>

Table 9-1. Troubleshooting Battery System (Cont)

CONDITION

TEST OR INSPECTION

CORRECTIVE ACTION

STEP 3. Check for bus voltage at pins A and G of volt/ loadmeter connector (2M1P1).

Replace volt/loadmeter (2M1) if voltage is present (paragraph 8-1).

STEP 4. Ensure that ground potential is present at terminal 2 of **P** BAT **E M** BATTERY switch (2S1). Check for ground potential at terminal 3 of **P** BAT **E M** BATTERY switch.

Replace switch if defective (paragraph 9-16).

STEP 5. Ensure that ground potential is present at terminal 2 of ELEC PWR — EMER OFF switch (2S4). Check for ground potential at terminal 1.

Replace switch if defective (paragraph 9-16).

STEP 6. **P** Disconnect connector (19K1P1) from gun clearing relay. Ensure that ground potential is available at pin D. Temporarily place a jumper between pin D and pin H and check for voltage on 28 Vdc bus,

Replace gun clearing relay (19K1) if voltage is present on 28 Vdc bus (paragraph 9-16).

STEP 7. **P** Ensure that ground potential is present at terminal X2 and check for actuating voltage at terminal X1 of battery relay (2K2).

Replace battery relay if defective (paragraph 9-16).

STEP 8. **E M** Ensure that ground potential is present at terminal NEG and check for actuating voltage at terminal BAT of battery relay (2K2).

Replace battery relay if defective (paragraph 9-16).

2. Voltmeter indicates plus 28 volts dc with ELEC PWR — EMER OFF switch in the EMER OFF position, DC VM circuit breaker closed, and **P** BAT **E M** BATTERY switch in **P** ON **E M** RUN position.

STEP 1. Check for continuity between terminals 1 and 2 with ELEC PWR — EMER OFF switch in EMER OFF position.

Replace switch if defective (paragraph 9-16).

3. **P** Battery does not provide power to non-essential bus with ELEC PWR — EMER OFF switch set to ELEC PWR, BAT switch set to ON, NON-ESNTL BUS switch (2S2) set to MANUAL position, and GEN BUS RESET circuit breaker closed.

STEP 1. With a multimeter (T77), or equivalent, determine if voltage is present on 28 Vdc essential bus.

If voltage is present on essential bus, continue with Step 2, If voltage is not present on essential bus, accomplish Steps 4 through 7 of condition 1.

Table 9-1. Troubleshooting Battery System (Cont)

---

CONDITION

TEST OR INSPECTION

**CORRECTIVE ACTION**

STEP 2. Check for bus voltage on switch side of GEN BUS RESET circuit breaker

**Replace circuit breaker if defective (paragraph 9-23).**

STEP 3. Check for bus voltage at terminals 1 and 2 of NON-ESNTL BUS switch (2S2).

**Replace switch if defective (paragraph 9-16).**

STEP 4. Ensure that ground potential is present at terminal X2 and check for bus voltage at terminal X1 of non-essential bus relay (2K4).

**Replace non-essential bus relay if actuating voltage is present and relay is not actuated (paragraph 9-16).**

---

**9-43. BATTERY.**

**9-44. DESCRIPTION - BATTERY.**

The 24-volt, 22-ampere/hour nickel-cadmium type battery is installed in the aft electrical compartment. The battery provides engine starting power, back-up emergency power, and **P** gun drive power during firing of the turret weapons. The battery installation includes vent tubes, eyebolts for attaching tiedown rods, and battery cables.

**9-45. CLEANING BATTERY.**

a. Clean battery in accordance with procedures contained in TM 11-6140-203-14-2.

b. Clean battery compartment in accordance with procedures contained in TM 55-1500-333-24.

**9-46. INSPECTION - BATTERY.**

Accomplish inspection of battery in accordance with procedures contained in TM 11-6140-203-14-2.

### 9-47. CONDITION - BATTERY.

A fully charged battery can be determined only by moving **P** **BAT** **E** **M** **BAT** ~ BATTERY switch from **P** ON **E** **M** RUN RUN to OFF and observing the effect on the generator loadmeter. If the change in indications is less than 5 amperes, the battery is fully charged.

### 9-48. SERVICE - BATTERY.

Service battery in accordance with procedures contained in TM11-6140-203-14-2.

### 9-49. REMOVAL - BATTERY.



The electrolyte used in nickel-cadmium batteries contains potassium hydroxide (KOH), which is a caustic chemical agent. Serious and deep burns of body tissue will result if the electrolyte comes in contact with the eyes or any part of the body.

Use rubber gloves, rubber apron, and protective eye covering when handling the battery. If accidental contact with the electrolyte is made, use ONLY clean water and immediately (seconds count). Flush contaminated areas. Continue flushing with large quantities of clean water. Seek medical attention immediately.

Before removing or installing the battery, ensure that the battery switch is off and the battery has cooled down if overheated. Removal or installation of the battery connector while the battery is under load may result in explosion, electrical arcing and possible severe burns to personnel.



Take every possible step to keep the nickel-cadmium battery as far away as possible from the lead-acid type battery.

Do not use the same tools and materials (screwdrivers, wrenches, gloves, apron, etc.) for both types of batteries.

Anything associated with the lead-acid battery, even the air, must never come in contact with the nickel-cadmium battery or its electrolyte. Even a trace of sulfuric acid fumes from a lead-acid battery may result in damage to the nickel-cadmium battery. If sulfuric acid has been inadvertently mixed with the electrolyte in the battery, the upper areas of the cells will appear greenish in color. In such cases, the battery must be replaced.

- a. Check that **P** **BAT** **E** **M** **BAT** ~ **M** BATTERY switch is OFF, and external power is not applied. Open compartment door.
- b. Disconnect battery cable connector by turning knob counterclockwise.
- c. Disconnect two vent tubes from battery case.
- d. Open tiedown clamps and disengage rods from battery cover. Lift battery from compartment.
- e. Close compartment door.

### 9-50. REPAIR - BATTERY.

Repair battery in accordance with procedures contained in TM 11-6140-203-14-2.

### 9-51. INSTALLATION - BATTERY.

- a. Open compartment door.
- b. Place battery on shelf, aligned for connections. Engage tiedown rods to strap on cover. Secure with lockwire (C137).
- c. Check vent line for obstruction. Connect two vent tubes to battery case and tighten clamps fingertight.
- d. Insert cable connector in battery receptacle and secure by turning knob clockwise.

e. Ensure that DC VM circuit breaker and loadmeter circuit breakers are closed.

f. Position **P** BAT ~~ BATTERY switch to **P** ON ~~ RUN. Check that battery voltage is indicated on voltmeter.

g. Check voltage regulator output. (Refer to paragraph 9-94 for proper output.)

### 9-52. BATTERY RELAY.

### 9-53. DESCRIPTION - BATTERY RELAY.

The battery relay is located in the aft compartment and serves to control battery power as described in paragraph 9-40. (Refer to paragraphs 9-18 through 9-22 for maintenance procedures.)

### 9-54. **P** TURRET POWER RELAY.

### 9-55. **P** DESCRIPTION - TURRET POWER RELAY.

The turret power relay (2K3) is located in the aft compartment and serves to control battery power as described in paragraph 9-40. (Refer to paragraph 9-18 through 9-22 for maintenance procedures.)

### 9-56. **P** GUN CLEARING RELAY.

### 9-57. **P** DESCRIPTION - GUN CLEARING RELAY.

The gun clearing relay (19K1) is located in pilot section left well and serves to control battery power to turret system. (Refer to paragraphs 9-18 through 9-22 for maintenance procedures.)

### 9-58. EXTERNAL POWER SYSTEM.

### 9-59. DESCRIPTION - EXTERNAL POWER SYSTEM.

External power may be used for system checkout or other ground operations. External power is connected

to the essential bus through an external power receptacle (2J1), located on the aft left side of the fuselage, and an external power relay (2K1). If the external power is of correct polarity, the external power relay closes automatically which connects the external power to the essential bus. If external power polarity is incorrect, diode (2CR5) in external power relay ground circuit prevents actuation of the external power relay. This protects installed equipment from being damaged by inadvertent application of power of wrong polarity. Helicopter circuits are not protected against overvoltage when operating on external power.

### 9-60. FUNCTIONAL TEST - EXTERNAL POWER SYSTEM .

a. Before connecting external power, open all circuit breakers.

b. Apply an isolated source 28 Vdc of reverse polarity between the small pin on the external power receptacle and the frame of the helicopter. Check that the external power relay does not close. Remove 28 Vdc reverse polarity.

c. Connect a 28 Vdc external power source to the helicopter external power receptacle (2J1). Energize power source. Close DC VM circuit breaker. The dc voltmeter should indicate external power on the essential bus.

### 9-61. TROUBLESHOOTING - EXTERNAL POWER SYSTEM.

Use Table 9-2 and perform checks as necessary to isolate trouble. Refer to paragraph F-9 in Appendix F for wiring diagrams. In the following table, tripped circuit breakers are omitted from indications of trouble. Such trouble is usually easily detected and corrected. Broken wiring is always a probable cause of circuit malfunction or failure and has not been included.

## NOTE

**Before you use this table, be sure you have performed all normal operational checks. If you have a malfunction which is not listed in this table, notify the next higher level of maintenance.**

Table 9-2. Troubleshooting External Power System

## CONDITION

## TEST OR INSPECTION

**CORRECTIVE ACTION**

1. Lack of power when external power plug is inserted into connector (2J1).

STEP 1. Ensure that connection between external power plug and connector (2J1) is tight. Check for reversed polarity in external power plug connections at external power source.

**Reconnect power cable at external power source attachment points if reversed.**

STEP 2. Check external power source for correct output voltage.

**Adjust external power source for correct output voltage.**

STEP 3. Ensure that ground potential is present at terminal X2 and actuating voltage is present at terminal X1 of external power relay (2K1). Check that relay (2K1) is actuated.

**Replace external power relay if defective (paragraph 9-16).**

2. Voltmeter indicates zero voltage with DC VM circuit breaker closed, caution lights circuit breaker closed, and external power applied to helicopter.

STEP 1. Ensure that ground potential is present at terminal X2 and actuating voltage is present at terminal X1 of external power relay (2K1). Check that relay (2K1) is actuated.

**Replace external power relay if defective (paragraph 9-16).**

STEP 2. Determine if diode (2CR5) across terminals 3 and 4 of terminal board (2TB1) is defective.

**Replace diode if defective (paragraph 9-16).**

3. Voltmeter indicates zero voltage, EXT PWR caution light is illuminated; DC VM circuit breaker closed; caution lights circuit breaker closed; and external power is applied to helicopter.

STEP 1. Check for essential bus voltage at pins A and G of connector (2M1P1).

**Replace volt-loadmeter (2M1) if defective (paragraph 8-1).**

STEP 2. Check for essential bus voltage on volt-loadmeter side of DC VM circuit breaker.

**Replace circuit breaker if defective (paragraph 9-23).**



Table 9-2. Troubleshooting External Power System (Cont)

---

<p>CONDITION</p> <p>TEST OR INSPECTION</p> <p><b>CORRECTIVE ACTION</b></p> <p>4. External power relay is energized with reverse polarity voltage applied to external power receptacle.</p> <p>STEP 1. Determine if diode (2CR5) across terminals 3 and 4 of terminal board (2TB1) is defective or installed incorrectly.</p> <p><b>Replace diode (2CR5) if defective. Reverse diode (2CR5) if installed incorrectly (paragraph 9-16).</b></p>	
---	--

---

**9-62. EXTERNAL POWER RECEPTACLE.**

**9-63. DESCRIPTION - EXTERNAL POWER RECEPTACLE.**

The external power receptacle (2J1) provides connection of an external power source to the helicopter. The receptacle is covered by an access door.

**NOTE**

External power should be utilized for engine start to prevent excessive battery drain.

**9-64. CLEANING - EXTERNAL POWER RECEPTACLE.**

Clean external power receptacle in accordance with paragraph 9-18.

**9-65. INSPECTION - EXTERNAL POWER RECEPTACLE.**

Inspect external power receptacle in accordance with paragraph 9-19.

**9-66. REMOVAL - EXTERNAL POWER RECEPTACLE.**

- a. Ensure all electrical power is OFF.

b. Remove nuts and washers from terminal posts of receptacle, identify and remove wires to receptacle from bracket. Cover wire ends with electrical tape. (C121).

c. Remove mounting screws and lift receptacle from bracket.

**9-67. REPAIR - EXTERNAL POWER RECEPTACLE.**

Repair external power receptacle in accordance with paragraph 9-21.

**9-68. INSTALLATION - EXTERNAL POWER RECEPTACLE.**

a. Position receptacle on bracket and install mounting screws.

b. Remove protective tape from electrical wires, and connect wires to respective receptacle terminals. -

**9-69. EXTERNAL POWER RELAY.**

**9-70. DESCRIPTION - EXTERNAL POWER RELAY.**

The external power relay (2K1) connects an external power source through the external power receptacle to the electrical system of the helicopter. A diode (2CR5), mounted on (2TB1), is located near the relay and serves to complete ground return for the holding

coil and prevents the application of reverse polarity to the helicopter electrical system. (Refer to paragraphs 9-18 through 9-22 for maintenance procedures.)

**9-71. P ( GENERATOR AND DC BUS SYSTEM.**

**9-72. P DESCRIPTION - GENERATOR AND DC BUS SYSTEM.**

The dc bus system supplies power for all de electrical components of the helicopter. This system is fed by external power, battery (2BT1), or the self-excited starter-generator (1MG1), which normally switches onto the main 28 Vdc bus after the engine start procedure when the generated voltage exceeds the voltage on the bus by **0.30 TO 0.42** volt. The application and regulation of power to the bus system is controlled by the generator shunt (2R1), reverse current relay (2K5), non-essential bus relay (2K4), generator field relay (2K6), voltage regulator (2VR1), and the bus control relay (2K7), all of which are located in the aft compartment.

**9-73. P FUNCTIONAL TEST - GENERATOR AND DC BUS SYSTEM.**

a. Open all circuit breakers.

b. Disconnect wires P26A1 and P26C4 from positive terminal B, and disconnect wires K5A1 and K5C4 from negative terminal E on the starter-generator. Observing proper polarity, connect these wires to an adjustable de power source (**26 TO 33** volts). Set voltage to **28** volts.

c. Energize the power source. Check that there is no voltage on the main 28 Vdc bus in the electrical compartment or on terminal A1 of starter relay (1K3).

d. Close GEN FIELD, GEN BUS RESET, DC VM, and CAUT LT circuit breakers. Place BAT switch (2S1)

to the ON position. Check that DC GEN caution lights on pilot and gunner caution panels are illuminated.

e. Return BAT switch (2S1) to OFF position.

f. Place GEN switch (2S3) to ON position. Reverse current relay (2K5) should close and both essential and non-essential buses should be energized. Check that DC GEN lights on pilot and gunner caution panels are not illuminated.

g. Close both ammeter circuit breakers. Momentarily turn on a load, such as the main inverter, and check that ammeter on pilot instrument panel reads upscale.

h. Slowly increase voltage of the power source. At **31 TO 33** volts, over-voltage relay in generator voltage regulator should actuate, causing field relay (2K6) to trip and reverse current relay (2K5) to open and thus remove voltage from all buses. Do not exceed **33** volts. Reduce voltage to **28** volts. Position BAT switch (2S1) to ON. Reset generator system by placing GEN switch (2S3) to RESET position and then to OFF. Return BAT switch (2S1) to OFF. Position GEN switch (2S3) to ON. Field relay (2K6) should reset and reverse current relay (2K5) should reclose, again energizing both de buses. Open all circuit breakers and reconnect wires to their proper terminals.

**9-74. P TROUBLESHOOTING - GENERATOR AND DC BUS SYSTEM.**

Refer to paragraph F-9 in Appendix F for wiring diagram. Use table 9-3 and perform checks as necessary to isolate trouble. In the following table, tripped circuit breakers are omitted from indications of trouble. Such trouble is usually easily detected and corrected. Broken wiring is always a probable cause of circuit malfunction or failure and has not been included.

## NOTE

Before you use this table, be sure you have performed all normal operational checks. If you have a malfunction which is not listed in this table, notify the next higher level of maintenance.

Table 9-3. **P** Troubleshooting Generator and DC Bus System

---

CONDITION

## TEST OR INSPECTION

**CORRECTIVE ACTION**

1. DC GEN caution lights fail to illuminate with caution lights circuit breaker closed; BAT switch set to ON; voltmeter indicating battery voltage.

STEP 1. Check for defective lights.

**Replace lights if defective (paragraph 9-282).**

STEP 2. Ensure that ground potential is present at terminal A2 and check for continuity between terminals A2 and A3 of bus control relay (2K7).

**Replace relay if defective (paragraph 9-16).**

2. DC GEN caution lights do not go out and non-essential dc bus is not energized under these conditions: GEN BUS RESET circuit breaker closed; CAUT LT circuit breaker closed; BAT switch set to ON; helicopter engine running; GEN FIELD circuit breaker closed; NON-ESNTL BUS switch set to NORMAL.

STEP 1. Ensure that actuating voltage is present at terminal X1 and ground potential is present at terminal X2 of bus control relay (2K7). Determine if relay is actuated.

**Replace relay if defective (paragraph 9-16).**

STEP 2. Check for dc voltage on SW terminal of reverse current relay (2K5). Determine if relay is actuated.

**Replace relay if defective (paragraph 9-16).**

STEP 3. Determine if generator field relay (2K6) is tripped or defective.

**Replace relay if defective (paragraph 9-16).**

STEP 4. Check for proper operation of GEN switch (2S3).

**Replace switch if defective (paragraph 9-16).**

STEP 5. Determine if ELECT PWR - EMER OFF switch (2S4) is defective.

**Replace switch if defective (paragraph 9-16).**

Table 9-3. **P** Troubleshooting Generator and DC Bus System (Cont)

---

CONDITION

TEST OR INSPECTION

**CORRECTIVE ACTION**

STEP 6. Determine if generator is defective.

**Replace starter-generator (1MG1) if defective (paragraph 9-79).**

3. DC GEN caution lights are not illuminated with essential dc bus energized; NON-ESNTL BUS switch in NORM position; ELEC PWR - EMER OFF switch in ELEC PWR position; GEN BUS RESET circuit breaker closed; GEN FIELD circuit breaker closed; CAUT LT circuit breaker closed and helicopter engine running.

STEP 1. Ensure that actuating voltage is present at terminal X1 and ground potential is present at terminal X2 of bus control relay (2K7). Determine if relay is actuated.

**Replace relay if defective (paragraph 9-16).**

STEP 2. Check for bus voltage on switch side of GEN BUS RESET circuit breaker.

**Replace circuit breaker if defective (paragraph 9-23).**

STEP 3. Check NON-ESNTL BUS switch for proper operation.

**Replace switch if defective (paragraph 9-16).**

4. Conditions same as described in condition 3 above, except DC GEN caution light is illuminated and GEN switch (2S3) has been positioned to RESET and returned to ON.

STEP 1. Ensure that actuating voltage is present at SWterminal of reverse current relay (2K5) and check for defective relay.

**Replace relay if defective (paragraph 9-16).**

STEP 2. Determine if generator field relay (2K6) is tripped.

**Replace relay if defective (paragraph 9-16).**

STEP 3. Check for defective GEN switch (2S3).

**Replace switch if defective (paragraph 9-16).**

STEP 4. Check for bus voltage on switch side of GEN BUS RESET circuit breaker (2CB3).

**Replace circuit breaker if defective (paragraph 9-23).**

STEP 5. Check for defective ELEC PWR - EMER OFF switch (2S4).

**Replace switch if defective (paragraph 9-16)**

Table 9-3. **P** Troubleshooting Generator and DC Bus System (Cont)

## CONDITION

## TEST OR INSPECTION

**CORRECTIVE ACTION**

STEP 6. Check for bus voltage on relay side of GEN FIELD circuit breaker (2CB4).

**Replace circuit breaker if defective (paragraph 9-23).**

STEP 7. Determine if generator voltage regulator (2VR1) is defective.

**Replace generator voltage regulator if defective (paragraph 9-90).**

STEP 8. Determine if starter generator is defective.

**Replace starter-generator if defective (paragraph 9-79).**

5. Loss of dc voltage on non-essential bus. NON-ESNTL BUS switch (2S2) is in NORMAL position.

STEP 1. Determine if starter-generator is defective.

**Replace starter-generator if defective (paragraph 9-79).**

STEP 2. Ensure that actuating voltage is present on terminal X1 of non-essential bus relay (2K4) and determine if relay is defective.

**Replace relay if defective (paragraph 9-16).**

STEP 3. Determine if NON-ESNTL BUS switch (2S2) is defective.

**Replace switch if defective (paragraph 9-16).**

STEP 4. Ensure that actuating voltage is present on terminal X1 of bus control relay (2K7) and determine if relay is defective.

**Replace relay if defective (paragraph 9-16).**

6. Loss of voltage on non-essential bus when NON-ESNTL BUS switch is in MANUAL position and GEN BUS RESET circuit breaker is closed.

STEP 1. Check for defective NON-ESNTL BUS switch (2S2).

**Replace switch if defective (paragraph 9-16).**

STEP 2. Ensure that actuating voltage is present on terminal X1 of non-essential bus relay (2K4) and determine if relay is defective.

**Replace relay if defective (paragraph 9-16).**

Table 9-3. **P** Troubleshooting Generator and DC Bus System (Cont)

CONDITION

TEST OR INSPECTION

**CORRECTIVE ACTION**

STEP 3. Check for bus voltage on switch side of GEN BUS RESET circuit breaker.

**Replace circuit breaker if defective (paragraph 9-23).**

7. Volt-loadmeter does not indicate proper load with normal loads operating.

STEP 1. Check for defective loadmeter circuit breakers (2CB1 and 2CB2).

**Replace circuit breaker if defective (paragraph 9-23).**

STEP 2. Determine if volt-loadmeter is defective.

**Replace volt-loadmeter if defective (paragraph 8-1).**

STEP 3. Check for defective shunt (2R1).

**Replace shunt if defective (paragraph 9-16).**

**9-75. E M GENERATOR POWER SYSTEM.**

connect the generator output wires to the PWR XFR BUS.

**9-76. E M DESCRIPTION - DC GENERATOR POWER SYSTEM.**

The DC Generator Power System consists of the starter-generator (1MG1) operating in generator mode, generator field relay (2K6), electrical power switch (2S4), generator switch (2S3), voltage regulator (2VR1), load meter shunt (2R1), and reverse current relay (2K5).

When the GEN FIELD and GEN BUS RESET circuit breakers are closed, generator field has been reset, GEN switch is in ON position, and generator is rotating at an appropriate speed, a voltage will be generated at the output terminals B and E of the starter generator. (ELEC PWR switch is assumed to be locked in the ELEC PWR position.) The generator output voltage is sensed by the reverse current relay. When the generator output voltage exceeds the voltage on the essential bus by **0.30 TO 0.42** volt, the contacts of the reverse current relay close and

**9-77. E M FUNCTIONAL TEST - DC GENERATOR POWER SYSTEM.**

a. Open all circuit breakers.

b. Disconnect wires (P26A1 and P26C4 from terminal B(+)) and wire K5A1 from terminal E (-) on the starter-generator. Leave wire K5C4 firmly connected as installed. Connect these disconnected wires to an adjustable external dc power source, observing proper polarity.

c. Energize the power source and set voltage at 28 Vdc. There should be no voltage on the PWR XFR BUS or other buses in the electrical compartment.

d. Close GEN FIELD, GEN BUS RESET, and DC VM circuit breakers. Position BATTERY switch (2S1) to START. Voltmeter should indicate battery voltage.

e. Position GEN switch (2S3) to RESET and release. Return battery switch to OFF.

f. Position GEN switch (2S3) to ON. Reverse current relay (2K5) should close, energizing the PWR XFR BUS.

g. Close both loadmeter circuit breakers. Check that loadmeter reads upscale.

**NOTE**

**If power source is not available refer to next higher level of maintenance.**

h. Slowly increase voltage of the power source. At **31 TO 33** volts, over-voltage relay in generator voltage regulator should actuate, causing field relay (2K6) to trip and reverse current relay (2K5) to open and thus remove voltage from all buses. Do not exceed **33** volts. Reduce voltage to **28** volts. Position BATTERY switch (2S1) to START. Reset generator system by placing GEN switch (2S3) to RESET position and then to OFF. Return BATTERY switch (2S1) to OFF. Position GEN switch (2S3) to ON. Field relay (2K6) should reset and reverse current relay (2K5) should reclose, again energizing both dc buses. Open all circuit breakers and reconnect wires to their proper terminals.

i. Start engine and allow to warm up in accordance with TM 55-1520-236-10. Adjust speed to idle speed. Position GEN switch (2S3) to ON and battery switch to run. Check that generator output voltage is within normal operating range of 27.5 ± 0.25 volts dc.

j. Increase engine speed to normal flight speed. Energize the electrical equipment. Use an accurate voltmeter to measure and adjust the voltage on the PWR XFR BUS in accordance with paragraph 9-88.

k. De-energize all electrical equipment not needed for maintaining ground run operation. Check that the PWR XFR BUS voltage remains essentially unchanged.

**9-78. E M TROUBLESHOOTING - DC GENERATOR POWER SYSTEM.**

Refer to paragraph F-9 in Appendix F for wiring diagrams. Use Table 9-4 and perform checks as necessary to isolate trouble. In the following table, tripped circuit breakers are omitted from indications of trouble. Such trouble is usually easily detected and corrected. Broken wiring is always a probable cause of circuit malfunction or failure and has not been included.

**NOTE**

**Before you use this table, be sure you have performed all normal operational checks. If you have a malfunction which is not listed in this table, notify the next higher level of maintenance.**

Table 9-4. **E M** Troubleshooting DC Generator Power System

CONDITION

TEST OR INSPECTION

**CORRECTIVE ACTION**

1. DC GEN caution lights remain illuminated, starter-generator is rotating at normal operating speed. GEN FIELD, GEN BUS RESET, DC VM, CAUTION LT, RVS CUR RLY, and both LOADMETER circuit breakers are closed. GEN switch is in ON position. BATTERY switch is in RUN position.

STEP 1. Position GEN switch to OFF, then to RESET and back to ON.

**If DC GEN caution lights extinguish and remain extinguished, DC generator has been reset and normal operation resumed.**

Table 9-4. **E M** Troubleshooting DC Generator Power System (Cent)

CONDITION

TEST OR INSPECTION

CORRECTIVE ACTION

If DC GEN caution lights remain illuminated, continue with step 2.

**STEP 2.** Check for generator voltage (approximately 28 Vdc) on the PWR XFR BUS

If generator voltage is present on PWR XFR BUS, continue with step 3.

If generator voltage is not present on PWR XFR BUS, do step 7.

**STEP 3.** Check for approximately 28 Vdc on terminal XI of reverse current control relay (2K14).

If voltage is present, replace relay (2K14) (paragraph 9-1 6).

If voltage is not present, continue with step 4.

**STEP 4.** Check for 28 Vdc on load side of RVS CUR RLY circuit breaker (2CB 10).

If voltage is present, repair wiring between RVS CUR RLY circuit breaker through terminal board 2TB1-1E and 2TB1-1D to relay 2K14-X1.

If voltage is not present, continue with step 5.

**STEP 5.** Check for 28 Vdc on power side of RVS CUR RLY circuit breaker (2CB10).

If voltage is present, replace circuit breaker (2CB10) (paragraph 9-23).

If voltage is not present, continue with step 6.

**STEP 6.** Check for 28 Vdc on IND terminal of reverse current relay (2K5).

If voltage is present, repair wiring between 2K5-IND and circuit breaker (2CB10).

If voltage is not present, continue with step 7.

**STEP 7.** Check for generator output voltage on GEN terminal of reverse current relay (2K5).

If voltage is present at 2K5-GEN, continue with step 8.

If voltage is not present, do step 9.

**STEP 8.** Check for 28 Vdc on terminal SW of reverse current relay (2K5).

If voltage is present, replace reverse current relay (2K5) (paragraph 9-1 6).

If voltage is not present, continue with step 12.



Table 9-4.   Troubleshooting DC Generator Power System (Cent)

**CONDITION**

**TEST OR INSPECTION**

**CORRECTIVE ACTION**

**STEP 9.** Check for approximately 28 Vdc output voltage between terminals B and E (ground) of starter-generator.

If voltage is present, repair feeder circuit between generator terminal B and reverse current relay (2K5) terminal GEN.

If voltage is not present, continue with step 10.

**STEP 10.** Check for a voltage (exact value may vary) on terminal A of starter-generator.

If voltage is present, replace starter-generator (paragraph 4-121 ).

If voltage is not present, continue with step 11.

**STEP 11.** Check for a voltage (exact value may vary) on pin A of plug 2VR1P1 on voltage regulator (2VR1).

If voltage is present, replace generator field relay (2K6) (paragraph 9-86).

If voltage is not present, continue with step 12.

**STEP 12.** Check for 28 Vdc on load side of GEN FIELD circuit breaker (2 CB4).

If voltage is present, continue with step 13.

If voltage is not present, replace GEN FIELD circuit breaker (2CB4) (paragraph 9-23).

**STEP 13.** Check circuit between GEN FIELD circuit breaker (2CB4) through connector 2A1P2/2A1J2, terminals 9A, 9B, and 9C or 2TB1, connector 2A2J1/2A2P1, contacts 2 and 3 of GEN switch (2S3), contacts 4 and 5 of ELEC PWR switch (2S4), contacts B3 and B2 of generator field relay (2K6) to 2K5-SW.

If circuit continuity does not exist, repair wiring or replace components as required.

9-79. DC GENERATOR.

9-80. DESCRIPTION – DC GENERATOR.

●  The engine driven 30 volt, 300 ampere starter-generator, derated to 200 ampere, supplies the primary 28 volt direct current electrical power on the helicopter.

b.   An engine-driven 30 volt, 200 ampere starter-generator provides 28 Vdc power to the PWR XFR BUS.

9-81. CLEANING – DC GENERATOR.

a. Remove moisture and loose dirt with a clean, soft cloth.



Cleaning solvent is flammable and toxic. Provide adequate ventilation. Avoid prolonged breathing of solvent vapors and contact with skin or eyes.

b. Remove grease, fungus, and ground-in dirt, with a clean, lint-free cloth dampened with dry cleaning solvent (CI 1 2).

c. Remove dirt from electrical connectors with a bristle brush.

## 9-82. INSPECTION – DC GENERATOR.

a. Visually inspect generator for damage.

b. Check terminals for damage and terminal board to ensure that it is not warped or cracked.

c. Check brush cover for dents and loose or bent pins.

d. Check brushes for wear and freedom of movement in brush holders.

e. Check brush springs for proper tension on brushes.

f. Check all leads for indication of overheating and condition of insulation.

g. Check that proper amount of brush area is making contact with commutator (100 percent) in direction of rotation and a minimum of (75 percent axially) and that commutator is not coated with oil or grease.

h. Check drive spline for excessive wear by rocking armature back and forth. If rocking occurs, remove generator. (Refer to paragraph 9-83.)

i. Check drive shaft assembly splines for wear by measuring the tap land of each tooth. If top land dimension is 0.015 inch or less, replace the generator.

## 9-83. REMOVAL — DC GENERATOR.

a. Open engine cowling.

b. Remove gas producer (N1) tachometer generator. (Refer to paragraph 8-51.)

c. Disconnect two engine oil lines located just below gas producer tachometer generator mounting pod.

d. Remove screws to detach forward and aft ends of tail rotor driveshaft tunnel from engine firewalls, allowing tunnel to be lowered.

● . Disconnect electrical leads from starter-generator,

f. Remove clamp and detach flexible hose duct from shroud on forward end of starter-generator. Loosen two clamping bolts at left side of inlet shroud, and slide shroud aft for access to starter mounting studs. Disconnect main fuel line and cap off.

g. Loosen nuts and washers on six mounting studs. Turn starter-generator clockwise and pull straight aft until free of studs and driveshaft engagement. Cover mounting, pad.

### NOTE

Observe position of terminal block in relation to engine and reinstall starter-generator in same position.

h. Remove inlet shroud from forward end of starter-generator.

## 9-84. REPAIR – DC GENERATOR.

a. Repair brush cover dents in accordance with TM55-1 500-204-25/1.

b. AVIM Replace brush when cracked, chipped, or no part of diagonal groove on edge is visible.

(1) Loosen screw and remove brush cover band.

(2) Remove screw from brush pigtail being careful not to drop screw.

(3) Using needle nose pliers, carefully pull brush out of brush holder.

(4) Hold brush spring out of the way and insert replacement brush into brush holder. Ensure that spring seats properly on top of brush.

(5) Check brush springs for minimum tension of 2.8 pounds with a pull scale approximately 7/8 inch from center of spring.

(6) Install screw to secure brush pigtail.

(7) Install brush cover and tighten screw.

c. Replace warped or cracked terminal boards.

d. No other repairs are authorized.

**9-85. INSTALLATION - DC GENERATOR.**

a. On a new starter-generator, place inlet shroud on forward end of starter-generator, far enough aft to allow access to mounting flange. Install two bolts, with washers, at shroud clamping joint. Tighten bolts to hold temporary position of shroud with inlet pointing to right. (Refer to figure 4-34.)

**NOTE**

**Shaft splines maybe aligned by rotating gas producer tachometer generator drive with one-quarter inch drive extension and ratchet.**

**NOTE**

**Due to the limited accessibility of the nut and washer at the 11 o'clock position, this nut and washer may be left off.**

b. Remove mounting pad cover. Install new gasket. Coat starter-generator shaft and pack female splines of shaft in gearbox two-thirds (2/3) full with lubricant (item 85, table 1-3). Lift starter-generator to position on studs, meshing shaft splines. Turn counterclockwise and tighten mounting nuts.

c. Slide inlet shroud forward to normal position. Connect flexible duct to inlet and secure by clamp. Tighten two bolts at shroud clamping joint.

d. Connect electrical cable leads to starter-generator terminals.

**e. Position forward and aft ends of tail rotor driveshaft tunnel to engine firewalls, and attach with screws. Connect main fuel line.**

f. Reconnect two engine oil lines which were disconnected in paragraph 9-83c.

g. Install gas producer tachometer generator. (Refer to paragraph 8-54.)

h. Close engine cowling.

i. Perform operational and voltage check. Adjust voltage regulator as required (paragraph 9-94).

**9-86. GENERATOR FIELD RELAY.**

**9-87. DESCRIPTION-GENERATOR FIELD RELAY.**

The generator field relay (2K6) provides control of generator (1MG1) by opening and closing the generator shunt field. The relay is tripped by the generator overvoltage applied through the voltage regulator (2VR1) and maybe reset by GEN switch (2S3) which is located on pilot electrical panel (2A2). (Refer to paragraphs 9-16 through 9-22 for maintenance procedures.)

**9-88. LOADMETER SHUNT.**

**9-89. DESCRIPTION - LOADMETER SHUNT**

The loadmeter shunt (2R1) provides a voltage drop, proportional to the current, to operate the ammeter. (Refer to paragraphs 9-18 through 9-22 for maintenance procedures.)

**9-90. VOLTAGE REGULATOR.**

**9-91. DESCRIPTION - VOLTAGE REGULATOR.**

The voltage regulator (2VR1) regulates the voltage of the generator by increasing or decreasing resistance

of the shunt field circuit. The voltage regulator is adjustable from 27.0 to 29.0 Vdc.

**9-92. CLEANING -- VOLTAGE REGULATOR.**

**WARNING**

**Cleaning solvent is flammable and toxic. Provide adequate ventilation. Avoid prolonged breathing of solvent vapors and contact with skin or eyes.**

- a. Remove moisture and loose dirt with a clean, SOft cloth.
- b. Remove grease, fungus, and ground in dirt with a clean, lint-free cloth dampened with dry cleaning solvent (C112).
- c. Remove dirt from electrical connectors with a bristle brush.

**9-93. INSPECTION - VOLTAGE REGULATOR.**

Visually inspect regulator case for physical damage that could impair normal efficient operation of the unit, (cracked case, damaged contact pins). Check for secure mounting of regulator.

**9-94. ADJUSTMENT - VOLTAGE REGULATOR.**

Electrical components normally depend upon a constant voltage supply from the generator. The generator voltage output is controlled by the voltage regulator which requires precision adjustment as follows:

- a. Run aircraft engine at normal RPM/percent.

- b. **P** Set BAT switch to ON position.
- c. **E M** Set BATTERY switch to RUN position.
- d. Set GEN switch to ON position.

NOTE

Adjust each voltage regulator independently with other generator(s) turned off.

- e. Close (on) all circuit breakers. Ensure all instruments and communications and navigation equipment are on. This will provide a load for the aircraft DC bus.

NOTE

An AN/UMSM-451 voltmeter or equivalent with a DC voltage scale accuracy of +/- one percent should be used. If a +/- one percent voltmeter is not available, an AN/USM-223 or equivalent multimeter may be used. However, the voltage regulator should be readjusted using an AN/USM-451 or equivalent voltmeter at the earliest possible time.

- f. Connect the positive probe of a voltmeter to any convenient point on the battery/essential bus. Connect the negative probe to a convenient aircraft ground.

- g. Read and record the voltage.

- h. Adjust the voltage regulator according to the seasonal average high (ambient ground level) temperature settings in Table 9-4.1.

TABLE 9-4.1 Voltage Regulator Adjustment Settings

SEASONAL AVERAGE HIGH (AMBIENT GROUND LEVEL) TEMPERATURE	VOLTAGE REGULATOR SETTING (VOLTS)
Above 80°F (26°C)	27.0 +/- 0.2
Between 32°F (0°C) and 80°F (26°C)	28.0 +/- 0.2
Below 32°F (0°C)	28.5 +/- 0.2

NOTE

On Standby/Auxiliary 28 VDC electrical system, adjust voltage regulators one volt lower than normal system.

i. Turn off all instruments and communications and navigation equipment. The DC bus voltage reading should be the same as in step g. above. If the aircraft DC voltage varies more than +/- 0.5 volt between the two readings, shut off aircraft engine (refer to TM 55-1520-238-10) and replace regulator.

#### **9-95. REMOVAL - VOLTAGE REGULATOR.**

- a. Be sure all electrical power is OFF.
- b. Disengage connector from voltage regulator. Cover connector openings. Remove mounting screws and remove regulator.

#### **9-96. REPAIR - VOLTAGE REGULATOR.**

Other than replacing loose or missing mounting screws, no other repairs are authorized.

#### **9-97. INSTALLATION - VOLTAGE REGULATOR.**

- a. Position regulator and secure with mounting screws.
- b. Remove protective covers from plug and receptacle. Engage connector and secure.

#### **9-98. REVERSE CURRENT RELAY.**

#### **9-99. DESCRIPTION -- REVERSE. CURRENT RELAY.**

The reverse current relay (2K5) prevents the generator from being connected to the line until operating voltage is attained, and prevents reverse current flow and holds generator on line unless voltage drops to the point where continued operation would be detrimental electrical equipment. (Refer to paragraphs 9-18 through 9-22 for maintenance procedures.)

**9-100. P BUS CONTROL RELAY.**

**9-101 P DESCRIPTION - BUS CONTROL RELAY.**

The bus control relay (2K7) is actuated from the indicator terminal of the generator reverse current relay (2K5). It also provides the following functions: energizes the non-essential bus relay (2K4) and allows power to be supplied to non-essential bus from either external power or generator. It also completes the circuit to illuminate DC GEN warning light segment on caution panels (8A2 and 8A3). (Refer to paragraphs 9-18 through 9-22 for maintenance procedures.)

**9-102. P NON-ESSENTIAL BUS REALY.**

**9-103. P DESCRIPTION - NON-ESSENTIAL BUS RELAY.**

The non-essential bus relay (2K4) is an electrically operated switch between the main 28 VDC bus and the non-essential bus. It is controlled by the bus control relay (2K7) when NON-ESNTL BUS switch (2S2) is in NORMAL position. (Refer to paragraphs 9-18 through 3-22 for maintenance procedures.)

**9-104. E M TRU POWER SYSTEM.**

**9-105. E M DESCRIPTION - TRU POWER SYSTEM.**

The TRU power system consists of the transformer-rectifier unit (TRU) (3PS2) and TRU remote control circuit breaker (RCCB) (3CB6). When the transmission driven alternator is operating and TRU circuit breaker is closed, the TRU remote control circuit breaker contacts will close. Closing of the RCCB contacts places 115 Vat, 3. phase, 400 Hz power on the input terminals of the TRU. The TRU output is 26 Vdc power which is connected directly to the TRU bus.

**9-106. E M FUNCTIONAL TEST - TRU SYSTEM.**

- a. Open (off) all circuit breakers.
- b. Place alternator in operation. Engine ground run is required. (Refer to TM55-1520-236-10.)
- c. Check for 28 Vdc on TRU BUS.

**9-107. E M TROUBLESHOOTING - TRU POWER SYSTEM.**

Refer to paragraph F-9 in Appendix F for wiring diagrams. Use Table 9-5 and perform checks as necessary to isolate trouble. In the following table, tripped circuit breakers are omitted from indications of trouble. Such trouble is usually easily detected and corrected. Broken wiring is always a probable cause of circuit malfunction or failure and has not been included.

**NOTE**

**Before you use this table, be sure you have performed all normal operational checks. If you have a malfunction which is not listed in this table, notify the next higher level of maintenance.**

**Table 9-5. E M Troubleshooting TRU Power System**

**CONDITION**

TEST OR INSPECTION

**CORRECTIVE ACTION**

1. RECT caution lights are illuminated. Alternator and starter-generator operating normally. TRU, CAUT LT and ARMT BUS circuit breakers are closed.  
STEP 1. Check for voltage on TRU BUS.  
**If voltage is present on TRU BUS, continue with STEP 2. If voltage is not present, continue with Step 4.**

Table 9-5. **E M** Troubleshooting TRU Power System (Cont)

CONDITION

TEST OR INSPECTION

**CORRECTIVE ACTION**

STEP 2. Check for voltage at terminal X1 of TRU RELAY (2K15).

**If voltage is present, replace relay (2K15) (paragraph 9-1 6). If voltage is not present, continue with Step 3.**

STEP 3. Check for voltage on load side of ARMT BUS circuit breaker.

**If voltage is present, repair wiring between ARMT BUS circuit breaker through connections on 2B1 -2F and -2A to relay 2K15-X2. Repair wiring. If voltage is not present, replace ARMT BUS circuit breaker (paragraph 9-23).**

STEP 4. Check for approximately 28 Vdc between positive and negative output terminals of TRU (3PS2). Check for firm ground connection on - terminal.

**If voltage is present, repair wiring between positive terminal of TRU and TRU BUS. If voltage is not present, proceed with Step 5.**

STEP 5. Check for 115VAC, 3 phase input power on input connector on TRU (3PS2). Check for solid, firm ground on terminal of input connector.

**If proper AC power is present on input terminals of TRU, replace TRU (3PS2) (paragraph 9-108). If proper AC power is not present on TRU input terminals, refer to AC power system for additional troubleshooting procedures.**

**9 - 1 0 8 . E M T R A N S F O R M E R - R E C T I F I E R U N I T .**

**9-109. DESCRIPTION - TRANSFORMER-RECTIFIER UNIT.**

The transformer-rectifier unit (TRU) requires 200/115V, 3 phase, neutral ground, wye-connected power for operation. The TRU transforms the 3 phase input voltage to a lower voltage, rectifies and filters it to produce 28 Vdc at its output terminals. Unit is rated at 200 amperes, 28 Vdc.

**9 - 1 1 0 . E M C L E A N I N G - T R A N S F O R M E R - R E C T I F I E R U N I T .**

a. Remove moisture and loose dirt with a clean, soft cloth.

**WARNING**

**Cleaning solvent is flammable and toxic. Provide adequate ventilation. Avoid prolonged breathing of solvent vapors and contact with skin or eyes.**

b. Remove grease, fungus, and ground-in dirt, with a clean, lint-free cloth dampened with dry cleaning solvent (C112).

c. Remove dirt from electrical connectors with a bristle brush.

9-111. Deleted.

9-112. **E M** REMOVAL —  
TRANSFORMER-RECTIFIER UNIT.

- a. Be sure all electrical power is off.
- b. Remove input connector (3PS2P1) and lay aside.

**WARNING**

To prevent possible shock hazard, discharge filter capacitor in transformer-rectifier unit.

- c. Temporarily short output terminals to discharge filter capacitor in output circuit.
- d. Remove the two dc output wires.
- e. Remove mounting screws and remove unit from helicopter.

9-113. **E M I** REPAIR - TRANSFORMER-RECTIFIER UNIT.

- a. Replace or tighten loose mounting screws,
- b. Straighten any bent connector pins.

9-114. **E M** INSTALLATION - TRANSFORMER-RECTIFIER UNIT.

- a. Position TRU in place and secure with mounting screws.
- b. Connect output leads, observing proper polarity.
- c. Connect plug (3PS2P1) to input receptacle (3PS2J1).

9-115. **E M** DC POWER DISTRIBUTION AND INTERCONNECT LOGIC,

9-116. **E M** DESCRIPTION - DC POWER DISTRIBUTION AND INTERCONNECT LOGIC.

The dc power distribution and interconnect logic consists of two power transfer buses, three load distribution buses, six bus interconnection relays, five interconnect logic relays, and crew station control switches. The PWR XFR BUS and the TRU BUS are supplied 28 Vdc power by the starter-generator and TRU, respectively. The three distribution buses, essential (ESS), non-essential (NON ESS) and armament (ARMT) buses are supplied with power from the PWR XFR BUS and the TRU BUS, as required, depending on crew station control settings and power plant operation. The bus interconnection relays (2K4, and 2K9 through 2K13) and the interconnect logic relays (2K8 and 2K14 through 2K17) control power transfer from the two 28 Vdc power sources, the battery, and external power to the load distribution buses. Any load distribution bus can be supplied with power from any of the ac power sources, depending on crew station switch settings and operating mode, except that the battery alone cannot supply the ARMT BUS. Interconnect logic circuits prevent incompatible power source interconnection. Refer to Table 9-6 for a tabulation of operational modes set up by the interconnect logic circuits under various conditions of crew switch settings and power source operation.

9-117. **E M** FUNCTIONAL TEST - DC POWER DISTRIBUTION AND INTERCONNECT LOGIC.

A complete functional test of the dc power distribution and interconnect logic circuitry requires that all three installed dc power sources be operational. This requires engine ground run so that the starter-generator and ac alternator can be operational. (The TRU requires ac input power from the alternator for operation.)

**NOTE**

The following functional tests require helicopter ground-run with engine operating.

- a. Operate helicopter in normal ground run with engine operating at normal flight rpm in accordance with TM 55-1520-236-10.



b. Activate each of the three installed dc power sources; dc generator, TRU, and the battery. Ensure that each source is operating normally and supplying power to its respective bus. (Refer to paragraph 9-39, 9-79, and 9-108, for operation and maintenance information for dc generator power system, TRU power system and battery system, respectively.)

c. Refer to Table 9-6. Position crew station control switches to establish the various conditions and modes tabulated under the heading of "CONDITIONS." Check that each of the dc buses is supplied with dc power from the particular dc power source indicated under the heading of "POWER SOURCE."

Table 9-6. **E M** DC Power Distribution Interconnection Logic Chart

ITEM NO.	CONDITIONS					BUS POWER SOURCE				
	BATTERY SW	MASTER ARM SW	NON ESS BUS SW	GENERATOR	TRU	PWR XFR BUS	ESS BUS	ARMT BUS	N-ESS BUS	TRU BUS
<b>NO EXTERNAL POWER</b>										
1	RUN/OFF	OFF	NORM/MAN	ON	ON	GEN	GEN	OFF	TRU	TRU
2	RUN/OFF	ARM/STBY	NORM/MAN	ON	ON	GEN	GEN	GEN	TRU	TRU
3	RUN/OFF	OFF	NORM/MAN	ON	OFF	GEN	GEN	OFF	GEN	OFF
4	RUN	ARM/STBY	NORM/MAN	ON	OFF	GEN	GEN	GEN	GEN	OFF
5	OFF	ARM/STBY	NORM/MAN	ON	OFF	GEN	GEN	OFF	GEN	OFF
6	RUN/OFF	OFF	NORM/MAN	OFF	ON	OFF	TRU	OFF	TRU	TRU
7	RUN	ARM/STBY	NORM/MAN	OFF	ON	OFF	TRU	TRU	TRU	TRU
8	OFF	ARM/STBY	NORM/MAN	OFF	ON	OFF	TRU	OFF	TRU	TRU
9	RUN	OFF	NORM	OFF	OFF	OFF	BAT	OFF	OFF	OFF
10	RUN	ARM/STBY	NORM	OFF	OFF	OFF	BAT	OFF	OFF	OFF
11	RUN	OFF	MAN	OFF	OFF	BAT	BAT	OFF	BAT	OFF
12	RUN	ARM/STBY	MAN	OFF	OFF	BAT	BAT	OFF	BAT	OFF
<b>EXTERNAL POWER APPLIED</b>										
13	RUN/OFF	OFF	NORM/MAN	ON	ON	GEN	EXT	OFF	TRU	TRU
14	RUN/OFF	ARM/STBY	NORM/MAN	ON	ON	GEN	EXT	GEN	TRU	TRU
15	RUN/OFF	OFF	NORM/MAN	ON	OFF	GEN	EXT	OFF	GEN	OFF
16	RUN/OFF	ARM/STBY	NORM/MAN	ON	OFF	GEN	EXT	GEN	GEN	OFF
17	RUN/OFF	OFF	NORM/MAN	OFF	ON	OFF	EXT	OFF	TRU	TRU
18	RUN/OFF	ARM/STBY	NORM/MAN	OFF	ON	OFF	EXT	TRU	TRU	TRU
19	RUN/OFF	OFF	NORM/MAN	OFF	OFF	EXT	EXT	OFF	EXT	OFF
20	RUN/OFF	ARM/STBY	NORM/MAN	OFF	OFF	EXT	EXT	EXT	EXT	OFF

**NOTE**

Where two switch positions are shown for a particular condition, either position gives the same result.

209475-447A

**9-118. E M TROUBLESHOOTING TROUBLESHOOTING - DC POWER DISTRIBUTION AND INTERCONNECT LOGIC.**

Refer to paragraph F-9 in Appendix F for wiring diagram and Table 9-6, dc power distribution and interconnect logic chart. Use Table 9-7 and perform

checks as necessary to isolate trouble. In the following table, tripped circuit breakers are omitted from indications of trouble. Such trouble is usually easily detected and corrected. Broken wiring is always a probable cause of circuit malfunction or failure and has not been included.

**NOTE**

**Table 9-7 does not address all operating conditions listed in Table 9-6. Table 9-7 includes only the operating conditions needed to achieve operation of each system component, so that any failed component can be detected.**

**Before you use this table, be sure you have performed all normal operational checks. If you have a malfunction which is not listed in this table, notify the next higher level of maintenance.**

**Table 9-7. E M Troubleshooting Troubleshooting DC Power Distribution and Interconnect Logic**

**CONDITION**

**TEST OR INSPECTION**

**CORRECTIVE ACTION**

1. Helicopter is operated in flight or engine ground run without external power applied. BATTERY switch is in RUN position, MASTER ARM SW is OFF, and GEN switch is ON. ALT, DC GEN, and RECT caution lights are extinguished. (Reference: Line No. 1 of Table 9-37.) DC VM reads slightly below normal (24V instead of 28). Battery may become discharged instead of charging. ESS bus is not energized by PWR XFR BUS.

STEP 1. Check for 28 Vdc on terminal X1 of ESS RLY (2K9).

**If voltage is not present, replace relay (2K9) (paragraph 9-16).**

**If voltage is present, do step 2.**

STEP 2. Check for voltage on load side of ESS BUS circuit breaker (2CB8) in aft electrical compartment.

**If voltage is present, do step 4.**

**If voltage is not present, continue with step 3.**

STEP 3. Check for voltage on bus side of circuit breaker (2CB8).

**If voltage is present, replace circuit breaker (2CB8) (paragraph 9-23).**

**If voltage is not present, check for battery voltage on ESS BUS.**

STEP 4. Check for voltage on terminal A2 of RVS CUR CONT RLY (2K14).

**If voltage is present, continue with step 5.**

**If voltage is not present, repair wiring between terminal A2 of relay (2K14) and circuit breaker (2CB8).**

Table 9-7. **E M** Troubleshooting DC Power Distribution and Interconnect Logic (Cont)

## CONDITION

## TEST OR INSPECTION

**CORRECTIVE ACTION**

STEP 5. Check for voltage on terminal A1 of relay (2K14).

**If voltage is present, check for circuit continuity between terminal A2 of relay (2K14) through normally closed contacts of EXT PWR CONT RLY (2K16), TRU CONT RLY (2K15), BAT CONT RLY (2K8) to terminal X1 of ESS RLY (2K9).**

**If voltage is not present, reset generator and check for open DC GEN caution light circuit.**

2. Helicopter is operated in flight or engine ground run (No external power applied). BATSW is in RUN position, MASTER ARM SW is OFF, GEN switch is ON. The ALT, DC GEN, and RECT caution lights are extinguished. (Reference: Line No. 1 of Table 9-6.) Non-essential bus does not become energized. Generator and TRU are operating.

STEP 1. Check for approximately 28 Vdc on terminal X1 of TRU NON ESS RLY (2K11).

**If voltage is present, replace relay (2K11) (paragraph 9-16).**

**If voltage is not present, check for voltage at terminal 14 of NON ESS RLY (2K4).**

**If voltage is present, replace relay (2K4).**

**If voltage is not present, continue with Step 2.**

STEP 2. Check for TRU BUS voltage at load side of TRU BUS circuit breaker (2CB9)

**If voltage is present, repair wiring between circuit breaker (2CB9) and NON ESS RLY (2K4), terminal 14.**

**If voltage is not present, check for voltage on power side of circuit breaker (2CB9).**

**If voltage is present, replace circuit breaker (2CB9) (paragraph 9-23).**

**If voltage is not present, repair wiring between circuit breaker and TRU BUS.**

3. Helicopter is operated in flight or engine ground run (No external power applied,). BATTERY switch is in RUN position, MASTER ARM SW is in STBY position and GEN switch is ON. ALT, DC GEN and RECT caution lights are extinguished, TRU and generator are in operation. (Reference: Line No. 2 of Table 9-6). Voltmeter indicates slightly low voltage reading (24 volts instead of 28V) (ESS BUS energized by battery only).

STEP 1. Check for voltage on terminal X1 of TRU ESS RLY (2K10).

**If voltage is present, replace relay (2K10) (paragraph 9-16).**

Table 9-7. **E M** Troubleshooting Troubleshooting DC Power Distribution and Interconnect Logic (Cont)

---

CONDITION

TEST OR INSPECTION

**CORRECTIVE ACTION**

**If voltage is not present, check for voltage on terminal 13 of ESS RLY (2K9).**

**If voltage is present, replace relay (2K9) (paragraph 9-16).**

**If voltage is not present, continue with Step 2.**

STEP 2. Check for TRU BUS voltage at load side of ARMT BUS circuit breaker (2CB9).

**If voltage is present, repair wiring between circuit breaker (2CB9) and terminal X1 on TRU ESS RLY (2K10).**

**If voltage is not present, check for voltage on power side of circuit breaker (2CB9).**

**If voltage is present, replace circuit breaker (2CB9) (paragraph 9-23).**

**If voltage is not present, repair wiring between circuit breaker and TRU BUS.**

4. Helicopter is operated in flight or engine ground without external power applied. BATTERY switch is in RUN position, MASTER ARM SWITCH is in STBY position, and GEN SW is ON. ALT, DC GEN, and RECT caution lights are extinguished. Generator and TRU are in operation. (Reference: Line No. 2 of Table 9-6). ARMT BUS is not energized.

STEP 1. Check for voltage on terminal X1 of ARMT RLY (2K13).

**If voltage is present, replace relay (2K13) (paragraph 9-16).**

**If voltage is not present, check for voltage at load side of RVS CUR circuit breaker (2CB10).**

**If voltage is present, repair wiring between circuit breaker (2CB10) and terminal X1 on ARMT RLY (2K13).**

**If voltage is not present, check for voltage on power side of RVS CUR circuit breaker (2CB10).**

**If voltage is present, replace breaker (2CB10) (paragraph 9-23).**

**If voltage is not present, repair wiring between circuit breaker and IND terminal of RVS CUR RLY (2K5).**

5. Helicopter is operated in flight or engine ground run with no external power applied. BAT switch is in RUN position, MASTER ARM switch in any position, and GEN switch is ON. DC GEN caution light is extinguished. Generator is operating but TRU is off. (Reference: Lines 3 and 4 of Table 9-6). NON ESS BUS will not energize.

STEP 1. Check for voltage on terminal X1 of NON ESS RLY (2K4).

**If voltage is present, replace relay (2K4).**

Table 9-7. **E M** Troubleshooting DC Power Distribution and Interconnect Logic (Cont)

## CONDITION

## TEST OR INSPECTION

**CORRECTIVE ACTION**

If voltage is not present, check for voltage at load side of ESS BUS circuit breaker (2CB8).

If voltage is present, check and repair wiring between circuit breaker (2CB8), through closed contacts of TRU CONT RLY (2K15) to terminal X1 of relay (2K4).

If voltage is not present, check for voltage on power side of circuit breaker (2CB8).

If voltage is present, replace circuit breaker (2CB8) (paragraph 9-23).

If voltage is not present, check and repair wiring between circuit breaker (2CB8) and ESS BUS.

6. Helicopter is operated in flight or engine ground run without external power applied. BATTERY switch is in RUN position, MASTER ARM switch is in STBY, GEN switch is in OFF position. ALTER and RECT caution lights are extinguished. DC GEN caution light is illuminated. TRU is operational. (Reference: Line No. 7 of Table 9-6). ARMT BUS is not energized from TRU BUS.

STEP 1. Check for voltage at terminal X1 of TRU ARMT RLY (2K12).

If voltage is present, replace relay (2K12) (paragraph 9-16).

If voltage is not present, check for voltage at load side of TRU BUS circuit breaker (2CB9).

If voltage is present, check and repair wiring between circuit breaker (2CB9), through contacts of BAT CONT RLY (2K8), normally closed contacts 13 and 14 of ARMT CONT RLY (2K17) to terminal X1 of TRU ARMT RLY (2K12).

If voltage is not present, check for voltage on power side of circuit breaker (2CB9).

If voltage is present, replace circuit breaker (2CB9) (paragraph 9-23).

If voltage is not present, check and repair wiring between circuit breaker (2CB9) and TRU BUS.

7. External power is applied to helicopter. BATTERY switch is in RUN position, MASTER ARM switch is set to STBY. Generator and TRU are both off. (Reference: Line No. 12 of Table 9-6). ESS BUS and NON ESS BUS are energized, but the ARMT BUS is not energized.

STEP 1. Check for voltage at terminal X1 of ARMT RLY (2K13).

If voltage is present, replace relay (2K13) (paragraph 9-16).

If voltage is not present, check for voltage at terminal B1 of ARMT CONT RLY (2K17).

If voltage is present at terminal F1 of relay (2K17) continue with step 2.

Table 9-7. **E M** Troubleshooting DC Power Distribution and Interconnect Logic (Cont)

CONDITON

TEST OR INSPECTION

**CORRECTIVE ACTION**

**If voltage is not present at terminal F1 of relay (2K17), continue with step 3.**

STEP 2. Check for voltage at terminal X1 of ARMT CONT RLY (2K17).

**If voltage is present at terminal X1 of relay (2K17), replace relay (2K17) (paragraph 9-16).**

**If voltage is not present at terminal X1 of relay (2K17), check and repair wiring to terminal X1 of relay 2K17 from turret armament system.**

STEP 3. Check for voltage at terminal F1 of EXT PWR CONT RLY (2K16).

**If voltage is present, check and repair wiring between terminal F1 of relay (2K16) through normally closed contacts of TRU CONT RLY (2K15) to terminal B1 of ARMT CONT RLY (2K17).**

**If voltage is not present, check for voltage at terminal X1 of EXT PWR CONT RLY (2K16).**

**If voltage is present, replace relay (2K16) (paragraph 9-16).**

**If voltage is not present, check for voltage at terminal 12 of EXT PWR RLY (2K1).**

**If voltage is present on terminal 12 of relay (2K1) replace circuit breaker (2CB7) and/or repair wiring between terminal 12 of relay (2K1) and terminal X1 of relay (2K16).**

**If voltage is not present, replace EXT PWR RLY (2K1) (paragraph 9-16).**

8. External power is applied to helicopter. Generator and TRU are both off, BATTERY switch is in RUN position, MASTER ARM switch is in STBY position. ESS BUS and ARMTBUS are energized. (Reference: Line No. 20 of Table 9-6.) NON ESS BUS is not energized.

STEP 1. Check for voltage at terminal X1 of NON ESS BUS RLY (2K4).

**If voltage is present, replace relay (2K4) (paragraph 9-16).**

**If voltage is not present, continue with step 2.**

STEP 2. Check for voltage at terminal X1 of EXT PWR CONT RLY (2K16).

**If voltage is present, continue with step 3.**

**If voltage is not present, check for voltage at terminal 12 of EXT PWR RLY (2K1).**

**If voltage is present on terminal 12 of relay (2K1) replace circuit breaker (2CB7) (paragraph 9-23), or repair wiring between relay 2K1, terminal 12 and relay 2K16, terminal X1.**

**If voltage is not present, replace EXT PWR RLY (2K1) (paragraph 9-16).**

Table 9-7. **E M** Troubleshooting DC Power Distribution and Interconnect Logic (Cont)

## CONDITION

## TEST OR INSPECTION

**CORRECTIVE ACTION**

STEP 3. Check for voltage at load side of ESS BUS circuit breaker (2CB8).

**If voltage is present, check and repair wiring from circuit breaker (2CB8) through normally closed contacts of TRU CONT RLY (2K15), actuated contacts of EXT PWR CONT RLY (2K16) to terminal X1 of NON ESS BUS RLY (2K4).**

**If voltage is not present, check for voltage on power side of ESS BUS CIRCUIT BREAKER (2CB8).**

**If voltage is present, replace circuit breaker (2CB8) (paragraph 9-23).**

**If voltage is not present, repair wiring between circuit breaker (2CB8) and 28 Vdc ESS BUS in electrical compartment.**

9. External power is applied to helicopter. Generator and TRU are both off. BATTERY switch is in either RUN or OFF position. MASTER ARM switch is in STBY position. (Reference: Lines No. 19 and 20 of Table 9-6.) Only the ESS BUS becomes energized.

STEP 1. Check for voltage on PWR XFR BUS in electrical compartment.

**If PWR XFR BUS is energized, refer to conditions 6 and 7 and perform applicable troubleshooting procedures.**

**If PWR XFR BUS is not energized, check for voltage on terminal X1 of ESS RLY (2K9).**

**If voltage is present, replace relay (2K9) (paragraph 9-16).**

**If voltage is not present, check for voltage at terminal XI of EXT PWR CONT RLY (2K16).**

**If voltage is present, replace relay (2K16) (paragraph 9-16).**

**If voltage is not present, check for voltage at terminal 12 of EXT PWR RLY (2K1).**

**If voltage is present on terminal 12 of relay (2K1), replace circuit breaker (2CB7) (paragraph 9-23), and/or repair wiring between EXT PWR RLY, terminal 12 and EXT PWR CONT RLY (2K16), terminal X1.**

**If voltage is not present, replace EXT PWR RLY (2K1) (paragraph 9-16).**

STEP 2. Check for voltage on load side of ESS BUS circuit breaker (2CB8).

**If voltage is present, check and repair wiring from circuit breaker (2CB8) through diode (2CR2), through normally closed contacts of RVS CUR CONT RLY (2K14) and THRU CONT RLY (2K15), actuated contacts of EXT PWR CONT RLY (2K16) to terminal X1 of ESS RLY (2K9).**

Table 9-7. **E M** Troubleshooting DC Power Distribution and Interconnect Logic (Cont)

CONDITION

TEST OR INSPECTION

CORRECTIVE ACTION

If voltage is not present, check for voltage on power side of circuit breaker (2CB8).

If voltage is present, replace circuit breaker (2CB8) (paragraph 9-23).

If voltage is not present, repair wiring between circuit breaker (2CB8) and ESS BUS in electrical compartment.

### SECTION III. ALTERNATING CURRENT POWER DISTRIBUTION SYSTEM

#### 9-119. **P** ALTERNATING CURRENT POWER DISTRIBUTION SYSTEM.

#### 9-120. **P** DESCRIPTION - ALTERNATING CURRENT POWER DISTRIBUTION SYSTEM.

The alternating current power distribution system provides all primary power (115 volt alternating current) to the ac bus, which supplies ac power to the instruments, avionics systems, and armament subsystems.

#### 9-121. **P** INVERTER SYSTEM.

#### 9-122. **P** DESCRIPTION DESCRIPTION - INVERTER SYSTEM.

a. The inverter system is a dual system consisting of a 750 Va solid state, three phase, static main inverter, and a 250 Va motor driven standby inverter. Both units produce 115 Vac 400 Hz power. The inverter system is comprised of the main inverter (3PS1), main inverter power relay (3K1), main inverter overload sensor switch (3S2), standby inverter (3MG1), standby inverter power relay (3K2), standby inverter overload sensor switch (3S3), ac power control relay (3K3), three-phase to single-phase inverter relay (3K4), main ac fail relay (3K5), inverter select relay (3K6), standby ac fail relay (3K7), ac fail light relay (3K8), reference transformer (3T1), power factor correction capacitors 3C1 and 3C2, 11 5/28 Vac transformer (3T2), inverter switch (3S1)

on pilot electrical power panel (2S2), ac systems terminal board (3TB1), and MAIN INVTR and STBY INVTR segments (18 and 19) of pilot caution panel. The main-inverter is powered from the main 28 Vdc bus and protected by MAIN inverter overload sensor (3S2). The standby inverter is powered from the 28 Vdc non-essential bus and protected by the STBY inverter overload sensor (3S3). The reference transformer (3T1) is powered from the main inverter and protected by the REF XMFR circuit breaker (20CB4). The 11 5/28 Vac transformer is powered from the 115 Vac bus, protected by the 28 Vac XMFR circuit breaker (3CB3), and provides power for the 28 Vac bus. The main inverter, main inverter power relay, main inverter overload sensor switch, standby inverter, standby inverter power relay, standby inverter overload sensor switch, ac power control relay, three-phase to single-phase relay, main ac fail relay, inverter select relay, standby ac fail relay, ac fail light relay, and main inverter fail relay are located in the aft electrical compartment. The reference transformer, power factor correction capacitors, and 11 5/28 Vac Transformer are located in the pilot section left well, The inverter switch is located in pilot electrical power panel and the circuit breakers are located in the applicable circuit breaker panel.

b. The main invertersupplies single-phase power to the ac bus system until TOW is selected, then switches to three-phase power wired delta to feed the TOW missile subsystem and the reference transformer to supply the necessary power for the M65 TOW missile subsystem and M136 helmet sight



subsystem. The standby inverter provides normal single-phase power for the 115 Vac bus and is a backup unit for the main inverter. The standby inverter will not power the TOW missile subsystem. With the inverter switch positioned to MAIN, dc power from the 28 Vdc essential bus is routed through the main inverter power relay and main inverter overload sensor switch to the main inverter. The ac output of the main inverter is routed through the inverter select relay, three-phase to single-phase relay, and ac power control relay to the 115 Vac feeder bus. In the event of a main inverter failure, the standby inverter is automatically energized to supply power to the 115 Vac bus. With the inverter switch positioned to STBY, dc power from the 28 Vdc non-essential bus is routed through the standby inverter power relay and standby inverter overload sensor switch to the standby inverter. The ac output of the standby inverter is routed through the inverter select relay and ac power control relay to the 115 Vac bus. The 11 5/28 Vac transformer reduces 115 Vac to 28 Vac for 28 Vac equipment operation. The main and standby inverter overload sensor switches are thermal actuated and provide overload protection for the main and standby inverters. The main ac fail relay, ac fail light relay and/or standby ac fail relay, when de-energized, completes an electrical circuit to illuminate the MAIN INVTR or STBY INVTR segment of the pilot caution panel.

### 9-123. **P** FUNCTIONAL TEST - INVERTER SYSTEM.

a. Open all circuit breakers and place all switches to their OFF or normal positions. Connect 28 Vdc power source to external power receptacle (2J1). Energize power source.

b. Place NON-ESNTL BUS switch (2S2) to MANUAL. Close INV MAIN, INV STBY, GEN BUS RESET, CAUT LT, and all ac circuit breakers. Check that MAIN INVTR and STBY INVTR caution lights are illuminated.

c. Place INV selector switch (3S1), located on pilot electrical power panel to MAIN position. Check that main inverter and all ac instruments are energized. Check that both MAIN INVTR and STBY INVTR caution lights are extinguished.

d. Connect multimeter (T77) or equivalent and frequency meter (T7.1) or equivalent to the 115 Vac bus at engine vibration meter receptacle or other convenient monitoring point. Close all ac circuit breakers. Set essential bus voltage to **28 ±0.5 Vdc**.

Check that under preceding conditions, ac bus voltage is **115 + 2.5 OR -7.5 Vac** and that frequency is **400 ± 7 Hz**.

e. Open INV MAIN circuit breaker. Check that main inverter is de-energized, standby inverter is automatically energized, and STBY INVTR caution light is extinguished. MAIN INVTR caution light will be illuminated.

f. Place the INV selector switch to STBY, check that standby inverter is energized, that all ac instruments are energized, STBY INVTR caution light is extinguished and MAIN INVTR caution light is extinguished.

g. Connect multimeter (T77) and frequency meter (T7.1) to the 115 Vac bus at engine vibration meter receptacle or other convenient monitoring point. With essential dc bus voltage at **28 ±0.5 Vdc**, check that the ac bus voltage is **113.5 ±0.5 Vac**, and that frequency is **400 ± 18 Hz**.

h. Open the INV STBY circuit breaker. Check that standby inverter is de-energized, that all ac instruments are de-energized, and that MAIN INVTR caution light and STBY INVTR caution lights are illuminated.

i. Place INV selector switch to OFF and close INV MAIN and INV STBY circuit breakers. Check that MAIN INVTR and STBY INVTR caution lights remain illuminated. Check that main and standby inverters and all ac instruments are de-energized.

j. Place INV selector switch to MAIN, Check that no voltage is present on terminals (A-1 and B1) of the three-phase to single-phase relay (3K4), and that MAIN INVTR and STBY INVTR caution lights are extinguished.

k. Place the MODE SELECT switch on the gunners TOW control panel on GUN position. Check that **115 + 2.5, or -7.5 Vac** at a frequency of **400 ± 7 Hz** is present on terminals (A1 and B1) of the three-phase to single-phase relay (3K4) with respect to helicopter structure (grounded). Check that MAIN INVTR and STBY INVTR caution lights are extinguished.

1. Place the MODE SELECT switch to the STBY TOW, ARMED MAN, and then ARMED AUTO position. Check that the ac voltage and frequency are **113.5 ±0.5 Vac, and 400 ±18 Hz**, respectively, at

terminals (A1 and B1) of the three-phase to single-phase relay (3K4) for each of these switch positions. Check that MAIN INVT and STBY INVTR caution lights remain extinguished.

m. Place INV selector switch to STBY position. Check that there is no voltage at terminals (A1 and B1) of the three-phase to single-phase relay (3K4) and that STBY INVTR and MAIN INVTR caution lights are extinguished. Place INV selector switch to OFF.

**9-124. P TROUBLESHOOTING - INVERTER SYSTEM.**

Refer to paragraph F-9 in Appendix F for wiring diagram. Use table 9-8 and perform checks as necessary to isolate trouble. In the following table, tripped circuit breakers are omitted from indications of trouble. Such trouble is usually easily detected and corrected. Broken wiring is always a probable cause of circuit malfunction or failure and has not been included.

**NOTE**

**Before you use this table, be sure you have performed all normal operational checks. If you have a malfunction which is not listed in this table, notify the next higher level of maintenance.**

**Table 9-8. P Troubleshooting Inverter System**

---

CONDITION

TEST OR INSPECTION

**CORRECTIVE ACTION**

1. Main inverter (3PS1) fails to operate.

STEP 1. Ensure that voltage is present on 28 Vdc essential bus and check for bus voltage on switch side of MAIN INVT circuit breaker (3CB1).

**Replace circuit breaker if defective (paragraph 9-23).**

STEP 2. With inverter switch (3S1) in MAIN position, check for bus voltage on terminals 2 and 3 of switch.

**Replace switch if defective (paragraph 9-16).**

STEP 3. Check for bus voltage at terminals S1, S2, L1 and L2 of main inverter overload sensor switch (3S2).

**Replace main inverter overload sensor switch if defective (paragraph 9-16).**

**NOTE**

**If main inverter overload sensor switch is tripped due to overload condition, terminal S1 will be grounded causing INV MAIN circuit breaker (3CB1) to trip.**

STEP 4. Ensure that actuating voltage is present at terminal X1 and ground potential is present at terminal X2 of main inverter power relay (3K1). Determine if relay is actuated.

**Replace relay if defective (paragraph 9-16)**

Table 9-8. **P** Troubleshooting Inverter System (Cont)

## CONDITION

## TEST OR INSPECTION

**CORRECTIVE ACTION**

STEP 5. Determine if main inverter (3PS1) is defective.

**Replace inverter if defective (paragraph 9-133, 9-142)**

2. Standby inverter (3MG1) fails to operate.

STEP 1. Ensure that voltage is present on 28 Vdc non-essential bus and check for bus voltage on switch side of INV STBY circuit breaker (3CB2).

**Replace circuit breaker if defective (paragraph 9-23).**

STEP 2. With inverter switch (3S1) in MAIN position, check for bus voltage on terminals 5 and 6, with switch in STBY position, check for bus voltage on terminals 4 and 5.

**Replace switch if defective (paragraph 9-16).**

STEP 3. Check for bus voltage at terminals S1, S2, L1, and L2 of standby inverter overload sensor switch (3S3).

**Replace standby inverter overload sensor switch if defective (paragraph 9-16).**

**NOTE**

**If standby inverter overload sensor switch is tripped due to overload condition, terminal S1 will be grounded causing INV STBY circuit breaker (3CB2) to trip.**

STEP 4. Ensure that bus voltage is present at terminal X1 and ground potential is present at terminal X2 of standby inverter power relay (3K2). Determine if relay is actuated.

**Replace relay if defective.**

STEP 5. Determine if standby inverter is defective

**Replace inverter if defective.**

3. Inverter (either 3PS1 or 3MG1) operates, but no ac output to instruments.

STEP 1. With inverter operating, check for 115 Vac output.

**Replace inverter if defective. (Refer to paragraph 9-133 or paragraph 9-150 as applicable.)**

STEP 2. With main inverter operating, check that main ac fail relay (3K5), inverterselect relay (3K6), and ac power control relay (3K3) are actuated.

**Replace relay if defective (paragraph 9-16).**

Table 9-8. **P** Troubleshooting Inverter System (Cont)

CONDITION

TEST OR INSPECTION

**CORRECTIVE ACTION**

STEP 3. With standby inverter operating, check that inverter select relay (3K6) and ac power control relay (3K3) are de-energized.

**Replace relay if defective (paragraph 9-16)**

4. Improper inverter output voltage or frequency (either main inverter or standby inverter).

STEP 1. Check for low input voltage to inverter.

**Correct the cause of low primary voltage condition.**

**9-125. **E M** ALTERNATING CURRENT POWER DISTRIBUTION SYSTEM.**

**9-126. **E M** DESCRIPTION ALTERNATING CURRENT POWER DISTRIBUTION SYSTEM.**

The ac electrical system consists of a three phase, 115 Vac, 400 Hz power distribution bus system. The 115 Vac bus system is powered by either the inverter or the alternator depending on crew control switch settings and aircraft power plant operation. The primary ac electrical power system is a three phase wye connected arrangement that is supplied by a 120/208 Vat, 400 Hz, 10 kva alternator. Three phase primary ac power is supplied by the alternator to the essential ac buses, which power the transformer rectifier unit (TRU). The TRU supplies power only when the alternator is in operation since TRU input power is dependent on the alternator. Secondary ac power is supplied by a solid state, three phase, wye connected 115 Vat, 400 Hz, 750 Va inverter. Inverter power is utilized when engine speed is insufficient to bring the alternator on-line or an alternator failure occurs. The BATTERY switch activates the inverter in RUN position. The inverter is inhibited when the alternator is in operation. The ALTNR switch energizes the alternator to supply its power to the 115 Vac buses and TRU when in the ON position. It resets

the generator control unit when positioned to OFF RESET.

**9-127. **E M** ALTERNATOR SYSTEM**

**9-128. **E M** DESCRIPTION DESCRIPTION - ALTERNATOR SYSTEM.**

The alternator system is comprised of ALTNR switch (3S1), ELEC PWR switch (2S4), ac source relay (3K1), alternator control unit (3VR1), alternator (3G1) and current transformer (3T3). With engine running, ALTNR switch (3S1) positioned to ON position and ELEC PWR switch (2S4) positioned to ELEC PWR position, ac source relay (3K1) is energized allowing alternator (3G1) to furnish power to the ac distribution system. Alternator control unit (3VR1) and current transformer (3T3) are also activated by the switching procedure and monitor phase relationship and frequency at the alternator assuring that proper voltages and frequencies are furnished to the ac distribution system.

**NOTE**

**ELEC PWR switch (2S4), when positioned to the EMER OFF position, removes all electrical power from the helicopter systems.**

**9-129. E M INVERTER SYSTEM.****9-130. E M DESCRIPTION - INVERTER SYSTEM.**

The inverter system is comprised of BATTERY switch (2S1), ac source relay (3K1), ac control relay (3K2), inverter remote control circuit breaker (3CB7) and inverter (3PS1). With ALTNR switch (3S1) positioned to OFF RESET, ELEC PWR switch (2S4) positioned to ELEC PWR, and BATTERY switch (2S1) positioned to RUN, ac source relay (3K1) and ac control relay (3K2) are de-energized. A ground circuit for inverter remote control circuit breaker (3CB7) is furnished when the BATTERY switch (2S1) is positioned to RUN and INVTR circuit breaker (3CB1) is closed. With inverter remote control circuit breaker closed, 28 vdc is applied from essential relay (2K9) to the inverter. With power applied to the inverter, an output of 115 vac from the inverter is routed to the at/armament circuit breaker panel (3A1).

**9-131. E M FUNCTIONAL TEST - AC POWER SYSTEM.**

a. Connect ac voltmeter to ENG VIB METER receptacle (3J1).

b. Start helicopter engine in accordance with TM 55-1520-236-10.

**NOTE**

**With helicopter engine operating at 100 percent (6600 rpm) the alternator electrical output frequency should be 399 ±1 Hz.**

c. Open INV circuit breaker (3CB1) on the dc circuit breaker panel. Verify that no voltage is present at ENG VIB METER receptacle, and MASTER and ALTER caution lights are illuminated.

d. Position ALTNR switch (3S1) on pilot electrical control to ON. Reset MASTER caution light. Verify that 115 +2.5, -7.5 Vac is present at ENG VIB METER receptacle, and MASTER and ALTER caution lights are not illuminated.

e. Position ALTNR switch to OFF. Verify that no voltage is present at ENG VIB METER receptacle, and MASTER and ALTER caution lights are illuminated.

f. Position ALTNR switch to ON and ELEC PWR switch (2S4) on gunner miscellaneous control panel to ELEC PWR. Reset MASTER caution light. Verify 115 Vac is present at ENG VIB METER receptacle, and

MASTER and ALTER caution lights are not illuminated.

g. Position ELEC PWR switch to EMER OFF. Verify that no voltage is present at ENG VIB METER receptacle.

**NOTE**

**The reference transformer (3T1) is functionally tested when turret and TOW missile systems are operated, The 115/28 Vac transformer (3T4) is functionally tested when the gyromagnetic compass and adf navigation systems are operated.**

h. Connect dc voltmeter to transformer-rectifier unit (3PS2) positive and negative terminals. With the helicopter engine running, position ELEC PWR switch to ELEC PWR. Verify approximately 28 Vdc power is present between positive and negative terminals of transformer- rectifier unit.

i. Open TRU circuit breaker (3CB2) on the dc circuit breaker panel. Verify that no voltage is present at transformer-rectifier unit positive and negative terminals.

j. Close TRU and INV circuit breakers. Verify 115 Vac is present at ENG VIB METER receptacle and 28 Vdc is present at transformer-rectifier unit positive and negative terminals.

k. Position ALTNR switch to OFF and BATTERY switch to RUN. Verify that no voltage is present at transformer-rectifier unit positive and negative terminals.

l. Verify 115 + 2.5, or -7.5 Vac, 400 ±7 Hz is present at ENG VIB METER receptacle.

m. Perform helicopter engine shutdown in accordance with TM 55-1520-236-10.

**9-132. E M TROUBLESHOOTING - AC POWER SYSTEM.**

Refer to paragraph F-9 in Appendix F for wiring diagram. Use Table 9-9 and perform checks as necessary to isolate trouble. In the following table, tripped circuit breakers are omitted from indications of trouble. Such trouble is usually easily detected and corrected. Broken wiring is always a probable cause of circuit malfunction or failure and has not been included.

**NOTE**

**Before you use this table, be sure you have performed all normal operational checks. If you have a malfunction which is not listed in this table, notify the next higher level of maintenance.**

Table 9-9.   Troubleshooting roubleshooting AC Power System

CONDITION

TEST OR INSPECTION

**CORRECTIVE ACTION**

1. Alternator fails to supply ac power to ac system.

STEP 1. Check AC source relay (3K1) coil for open circuit.

**Replace relay if coil is open (paragraph 9-16).**

STEP 2. Check for defective ALTNR switch (3S1).

**Replace switch if defective (paragraph 9-16).**

STEP 3. Check for defective ELEC PWR switch (2S4).

**Replace switch if defective (paragraph 9-16).**

STEP 4. Check for defective alternator control unit (3VR1).

**Replace unit if defective (paragraph 9-206).**

STEP 5. Check for defective current transformer (3T3)

**Replace transformer if defective (paragraph 9-221).**

STEP 6. Check for defective alternator (3G1).

**Replace alternator if defective (paragraph 9-158).**

2. Inverter fails to supply ac power to ac system when ALTNR switch is in OFF RESET position.

STEP 1. Determine if the inverter is operating. If inverter is operating, check for 115 Vac output at the inverter connector (3PS1P2) pins A, B, and C.

**Replace inverter if 115 Vac is not present (paragraph 9-142).**

STEP 2. If inverter is not operating, check for 28 Vdc at the inverterconnector (3PS1P1) pin C, and ground at pin A.

**Replace inverter if 28 Vdc was present at 3PS1P1 pin C and ground was present at 3PS1P1 pin A (paragraph 9-142).**

Table 9-9. **E M** Troubleshooting AC Power System (Cont)

## CONDITION

## TEST OR INSPECTION

**CORRECTIVE ACTION**

STEP 3. Check for ground circuit at inverter circuit breaker (3CB7) terminal 3.

**Replace circuit breaker if ground circuit is present (paragraph 9-16).**

STEP 4. Deleted.

STEP 5. Check INV circuit breaker (3CB1) for continuity.

**Replace circuit breaker if continuity was not present (paragraph 9-16).**

STEP 6. Check BATTERY switch (2S1) for continuity from terminals 2 to 3 with switch in RUN position.

**Replace switch if continuity is not present (paragraph 9-16).**

**9-133. P MAIN MAIN INVERTER.****9-134. P DESCRIPTION - MAIN INVERTER.**

The main inverter is a 750 VA solid state, single-phase or three-phase delta-connected with an output of 115 + 2.5, or -7.5 Vac, 400 ± 7 Hz, 0.75 lagging to 0.95 leading power factor, 65 percent efficiency. The main inverter supplies single-phase power to the ac bus system until TOW is selected, then switches to three-phase power wired delta to power the ac bus system, TOW missile system, and reference transformer which supplies necessary power for the M65 TOW missile subsystem and M136 helmet sight subsystem.

**9-135. P CLEANING - MAIN INVERTER.**

a. Remove moisture and loose dirt with a clean, soft cloth.

**WARNING**

**Cleaning solvent is flammable and toxic. Provide adequate ventilation. Avoid**

**prolonged breathing of solvent vapors and contact with skin or eyes.**

b. Remove grease, fungus, and ground-in dirt with a clean, lint-free cloth dampened with dry cleaning solvent (C112).

c. Remove dirt from electrical connectors with a bristle brush.

**9-136. P INSPECTION - MAIN INVERTER.**

a. Inspect case for cracks or damage.

b. Inspect electrical connectors for broken pins or cracked connector inserts.

c. Check for bonding and security of mounting.

d. Check for faulty operation.

**9-137. P OPERATIONAL CHECK - MAIN INVERTER.**

Refer to paragraph 9-123 for operational check of main inverter.

**9-138. P ADJUSTMENT - MAIN INVERTER.**

No adjustment can be made. (Refer to TM 11-6130-385-34.)



**Carefully support inverter during removal and installation to preclude damage to equipment.**

**9-139. P REMOVAL - MAIN INVERTER.**

- a. Ensure all electrical power is OFF.
- b. Disconnect electrical connectors from inverter. Protect receptacles and plugs with caps or electrical tape (C121).
- c. Remove mounting bolts, washers, and nuts. Carefully lower inverter from compartment ceiling.

**9-140. P REPAIR - MAIN INVERTER.**

Repair connectors, and replace missing mounting bolts. For further repair refer to TM 11-6130-385-34.



**Carefully support inverter during removal and installation to preclude damage to equipment.**

**9-141. P INSTALLATION - MAIN INVERTER.**

- a. Ensure all electrical power is OFF.

**NOTE**

Some inverters have a thinner mounting flange than others. In these cases, use washers AN960PD516 between bolt head and mounting flange.

- b. Carefully position and secure inverter in compartment with mounting bolts, washers, and nuts.
- c. Remove caps or electrical tape from plugs and receptacles.
- d. Connect electrical connectors to the inverter.

**9-142. F M INVERTER.**

**9-143. F M DESCRIPTION - INVERTER.**

The inverter is a 750 Va, 3-phase, wye connected inverter. It receives power from the essential dc bus through the inverter remote control circuit breaker.

**9-144. F M CLEANING - INVERTER.**

- a. Remove moisture and loose dirt with a clean, soft cloth.



**Cleaning solvent is flammable and toxic. Provide adequate ventilation. Avoid prolonged breathing of solvent vapors and contact with skin or eyes.**

- b. Remove grease, fungus, and ground-in dirt with a clean, lint-free cloth dampened with dry cleaning solvent (C112).

- c. Remove dirt from electrical connectors with a bristle brush.

**9-145. F M INSPECTION INSPECTION - INVERTER.**

- a. Inspect case for cracks or damage.
- b. Inspect electrical connectors for broken pins or cracked connector inserts.
- c. Check for bonding and security of mounting.
- d. Check for faulty operation.

**9-146. F M ADJUSTMENT INVERTER.**

No adjustment can be made (Refer to TM 11-6130-385-34).



**Carefully support the inverter during removal and installation to preclude damage to equipment.**

**9-147. E M REMOVAL - INVERTER.**

- a. Ensure all electrical power is OFF.



b. Disconnect electrical connectors from inverter. Protect receptacles and plugs with caps or electrical tape (C121).

c. Remove mounting bolts, washers, and nuts. Carefully lower inverter from compartment ceiling.

#### 9-148. **E M** REPAIR - INVERTER.

Repair connectors, and replace mounting bolts. For further repair refer to TM 11-6130-385-34.

#### 9-149. **E M** INSTALLATION - INVERTER.

a. Ensure all electrical power is OFF.



**Carefully support the inverter during removal and installation to preclude damage to equipment.**

#### NOTE

**Inverter mounting pads may vary in thickness. Add washers as necessary for secure installation of inverter.**

b. Carefully position and secure inverter in compartment with mounting bolts, washers, and nuts.

c. Remove caps or electrical tape from plugs and receptacles.

d. Connect electrical connectors to the inverter.

#### 9-150. **P** STANDBY INVERTER.

#### 9-151. **P** DESCRIPTION - STANDBY INVERTER.

The standby inverter is a 250 VA motor-driven, single-phase inverter with an output of  $115 \pm 3$  Vac,  $400 \pm 7$  Hz, 0.80 lagging to 0.95 leading power factor. The standby inverter provides normal single-phase power for the 115 Vac bus and is a backup unit for the main inverter.

#### 9-152. **P** CLEANING - STANDBY INVERTER.

a. Remove moisture and loose dirt with a clean, soft cloth.

### WARNING

**Cleaning solvent is flammable and toxic. Provide adequate ventilation. Avoid prolonged breathing of solvent vapors and contact with skin or eyes.**

b. Remove grease, fungus, and ground-in dirt with a clean, lint-free cloth dampened with dry cleaning solvent (C112).

c. Remove dirt from electrical connectors with a bristle brush.

#### 9-153. **P** INSPECTION - STANDBY INVERTER.

a. Inspect case for cracks or damage.

b. Inspect electrical connectors for broken pins or cracked connector inserts.

c. Check for bonding and security of mounting.

d. Check for faulty operation.

#### 9-154. **P** ADJUSTMENT - STANDBY INVERTER.

a. Open aft compartment access door to gain access to the inverter.

#### NOTE

**To properly conduct the inverter check, apply a regulated 28 Vdc external power source or ground run the helicopter to assure an adequate source of dc power for inverter operation. Do not use helicopter battery power.**

b. Turn on inverter. Close all ac circuit breakers and actuate ac circuits.

c. Using multimeter (T77) and frequency meter (T7.1), check output voltage and frequency at the 115 Vac bus (engine vibration receptacle or other convenient monitoring point).

d. If the output voltage is  $115 \pm 2.5$  vac, and the frequency is between 380 and 520 Hz, no adjustment is necessary.

e. If the output voltage is above or below the limits prescribed in the preceding step, proceed as follows: Turn off the power to inverter. Remove cover from end of inverter. (It may be necessary to remove the inverter from mounting.) Loosen hex-head jam nut securing adjustment screw.

f. Close all ac circuit breakers. Actuate all ac circuits. Turn on inverter power. Connect multi meter and frequency meter at one of the test points described in step c. and note reading. Turn inverter output adjustment screw counterclockwise to increase or clockwise to decrease inverter output. Nominal setting of 111 volts at full output load should produce an output frequency within limits of 380 TO 420 Hz. See figure 9-12 for directional references.

**9-155. P REMOVAL - STANDBY INVERTER.**

- a. Ensure all electrical power is OFF.
- b. Disconnect electrical connector from inverter. Protect receptacle and plug with cap or electrical tape (C 121).
- c. Remove mounting bolts, washers, and nuts. Carefully lift inverter from compartment.

**9-156. P REPAIR - STANDBY INVERTER.**

Repair connectors, replace missing mounting bolts and replace unit if other inspection requirements are not met. (Refer to TM 11-6125-220-12 and -35.)

**9-157. P INSTALLATION - STANDBY INVERTER.**

- a. Ensure all electrical power is OFF.

b. Carefully position and secure inverter in compartment with mounting bolts, washers, and nuts.

c. Remove cap or electrical tape from plug and receptacle.

d. Connect electrical connector to the inverter.

**9-158. E M ALTERNATOR. ALTERNATOR.**

**9-159. E M DESCRIPTION - ALTERNATOR.**

The alternator is mounted on and driven by the transmission. It is rated at 10 kva, 3-phase, wye-connected, 120/208 v, 400 Hz. In normal operation, the alternator is energized and is driven at a speed corresponding to 100 percent or 324 rpm rotor speed. Under these operating conditions the frequency is  $399 \pm 1$  Hz. It is energized by placing ALTNR switch (3S1) to the ON position, and de-energized by placing this switch to OFF position. Alternator is automatically connected to the 3-phase AC buses when it is energized and the frequency is  $360 \pm 5$  Hz (corresponding to 90 percent or 292.5 RPM rotor speed) or higher. Alternator is automatically disconnected from the buses when de-energized, or when frequency falls below  $360 \pm 5$  Hz (below 90 percent rotor RPM).

Refer to paragraphs 9-126, 9-128, 9-131, and 9-132 for further information.

**9-160. E M CLEANING ALTERNATOR.**

- a. Remove moisture and loose dirt with a clean, soft cloth.

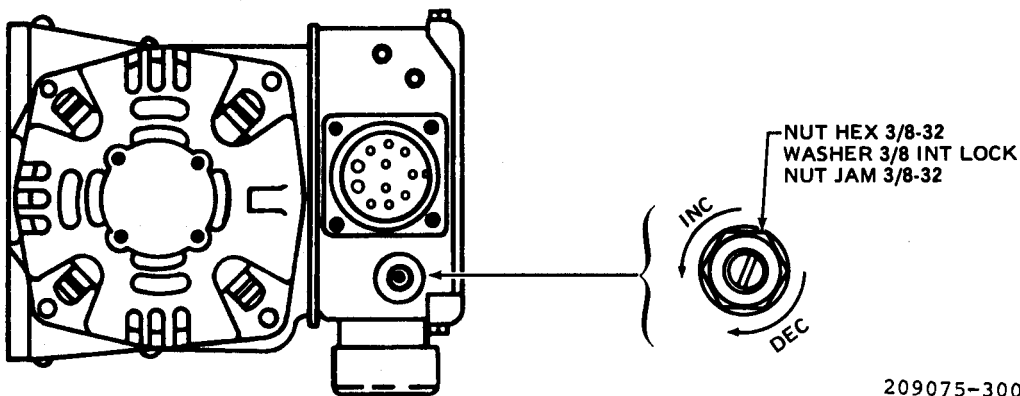

209075-300

Figure 9-12. P Standby Inverter Adjustment

**WARNING**

Cleaning solvent is flammable and toxic. Provide adequate ventilation. Avoid prolonged breathing of solvent vapors and contact with skin or eyes.

b. Remove grease, fungus, and ground-in dirt with a clean, lint-free cloth dampened with dry cleaning solvent (C112).

c. Remove dirt from electrical connectors with a bristle brush.

**9-161. g INSPECTION - ALTERNATOR.**

- a. Inspect case for cracks or damage.
- b. Inspect electrical connectors for broken pins or cracked connector inserts.
- c. Check for bonding and security of mounting.
- d. Check for faulty operation.

**9-162. E M ADJUSTMENT - ALTERNATOR.**

No adjustment can be made.

**9-163. E M REMOVAL - ALTERNATOR.**

- a. Ensure all electrical power is OFF.
- b. Open left transmission cowl.
- c. Disconnect electrical connectors from alternator. Protect receptacles and plugs with caps or electrical tape (C121).

**CAUTION**

Carefully support alternator during removal and installation to preclude damage to equipment.

- d. Remove lockwire, if installed, and loosen V-band attaching bolt. Remove V-band and remove alternator.

**9-164. E M REPAIR - ALTERNATOR.**

Repair connectors, and tighten loose terminals.

**9-165. E M INSTALLATION - ALTERNATOR.**

- a. Ensure all electrical power is OFF.
- b. Install packing on shaft.
- c. Apply light coat of grease (C85) on driveshaft and with wire bundles at 12 o'clock, carefully position alternator into drive quill splines.

**CAUTION**

Carefully support alternator during removal and installation to preclude damage to equipment.

Alignment pin on quill flange must align with corresponding hole in alternator flange.

**NOTE**

Clean mating splines before installation of alternator with plastilube.

- d. Reinstall V-band clamp. Tap around V-band clamp with plastic mallet to assure clamp is seated while torquing retaining nut 50 TO 70 inch-pounds.

- e. Remove caps or electrical tape from plugs and receptacles.

- f. Connect electrical connectors to the alternator.

- g. Close cowl.

**9-166. P MAIN INVERTER POWER RELAY.****9-167. P DESCRIPTION - MAIN INVERTER POWER RELAY.**

The main inverter power relay (3K1) is used as a remote controlled switch. When energized, 28 Vdc is routed from the essential bus through the main inverter overload sensor (3S2) to the main inverter (3PS1). (Refer to paragraph 9-18 through 9-22 for maintenance procedures.)

**9-168. P STANDBY INVERTER POWER RELAY.****9-169. P DESCRIPTION - STANDBY INVERTER POWER RELAY.**

The standby inverter power relay (3K2) is used as a remote controlled switch. When energized, 28 Vdc is routed from the Non-essential bus through the standby inverter overload sensor (3S3) to the standby

inverter (3MG1). (Refer to paragraphs 9-18 through 9-22 for maintenance procedures.)

**9-170. P MAIN INVERTER OVERLOAD SENSOR.**

**9-171. P DESC DESCRIPTION - MAIN INVERTER OVERLOAD SENSOR.**

The main inverter overload sensor (3S2) is used to automatically de-energize the main inverter power relay (3K1) when an overload exists between the main inverter (3PS1) and the 28 Vdc essential bus. (Refer to paragraphs 9-18 through 9-22 for maintenance procedures.)

**9-172. P STANDBY INVERTER OVERLOAD SENSOR.**

**9-173. P DESCRIPTION - STANDBY INVERTER OVERLOAD SENSOR.**

The standby inverter overload sensor (3S3) is used to automatically de-energize the standby inverter power relay (3K2) when an overload of current exists between the standby inverter (3MG1) and the 28 Vdc Non-essential bus, (Refer to paragraphs 9-18 through 9-22 for maintenance procedures.)

**9-174. P AC POWER CONTROL RELAY.**

**9-175. P DESCRIPTION - AC POWER CONTROL RELAY.**

The ac power control relay (3K3) is used as a double-pole, double-throw remote controlled switch. When energized, the relay separates and balances the ac loads on main inverter (3PS1). When de-energized, the relay connects the ac loads to the standby inverter (3MG1). (Refer to paragraphs 9-18 through 9-22 for maintenance procedures.)

**9-176. P INVERTER SELECT RELAY.**

**9-177. P DESCRIPTION - INVERTER SELECT RELAY.**

The inverter select relay (3K6) is used as a six-pole, double-throw remote controlled switch. The relay provides automatic switch-over to the standby inverter (3MG1) in the event of a main inverter failure and, also, provides control of the ac power control relay (3K6). (Refer to paragraphs 9-18 through 9-22 for maintenance procedures.)

**9-178. P THREE-PHASE TO SINGLE-PHASE INVERTER RELAY.**

**9-179. P DESCRIPTION - THREE-PHASE TO SINGLE-PHASE INVERTER RELAY.**

The three-phase to single-phase inverter relay (3K4) is used as a six-pole, double-throw remote controlled switch. When armament TOW mode is selected, the three-phase to single-phase inverter relay is energized to supply three-phase 115 Vac from the main inverter (3PS1) to the REF XFMR and TOW PWR circuit breakers. Also, a portion of the TOW blower circuit is completed when relay is energized. When relay is de-energized, 115 Vac (A phase) is routed to REF XFMR circuit breaker. (Refer to paragraphs 9-18 through 9-22 for maintenance procedures.)

**9-180. P MAIN AC FAIL RELAY.**

**9-181. P DESCRIPTION - MAIN AC FAIL RELAY.**

The main ac fail relay (3K5) monitors 115 Vac output from the main inverter (3PS1). When energized by main inverter output, the relay completes the circuit from INV MAIN circuit breaker to actuate the inverter select relay (3K6). When de-energized, the relay completes the INV MAIN caution light circuit. (Refer to paragraphs 9-18 through 9-22 for maintenance procedures.)

**9-182. P STANDBY AC FAIL RELAY.**

**9-183. P DESCRIPTION - STANDBY AC FAIL RELAY.**

The standby ac fail relay (3K7) monitors 115 Vac output from the standby inverter (3MG1). When energized by standby inverter output, the relay opens the INV STBY caution light circuit. When de-energized, the relay, in conjunction with de-energized inverter select relay (3K6), completes the INV STBY caution light circuit. (Refer to paragraphs 9-18 through 9-22 for maintenance procedures.)

**9-184. P MAIN MAIN INVERTER FAIL LIGHT RELAY**

**9-185. P DESCRIPTION - MAIN INVERTER FAIL LIGHT RELAY.**

The main inverter fail light relay (3K8) interrupts the MAIN INVTR caution light circuit when INV selector

switch is in the STBY INVTR position. When de-energized, this relay completes the MAIN INVTR caution light circuit. (Refer to paragraphs 9-18 through 9-22 for maintenance procedures.)

#### 9-186. 115/28 VAC TRANSFORMER.

#### 9-187. DESCRIPTION - 115/28 VAC TRANSFORMER.

The 115/28 Vac transformer (3T4) is an autotransformer that reduces 115 Vac to 26 Vac, to power the 26 Vac bus, for operation of navigation instruments.

#### 9-188. CLEANING - 115/28 VAC TRANSFORMER.

a. Remove moisture and loose dirt with a clean, soft cloth.

### WARNING

**Cleaning solvent is flammable and toxic. Provide adequate ventilation. Avoid prolonged breathing of solvent vapors and contact with skin or eyes.**

b. Remove grease, fungus, and ground-in dirt with a clean, lint-free cloth dampened with dry cleaning solvent (C112).

#### 9-189. INSPECTION - 115/28 VAC TRANSFORMER.

a. Inspect transformer for broken contact pins.

b. Inspect transformer case for damage.

c. Inspect for damaged insulation between terminals.

d. Check for discoloration that would indicate internal shorting or excessive overload.

e. Check for security of mounting.

#### 9-190. ADJUSTMENT - 115/28 VAC TRANSFORMER.

No adjustment can be made.

#### 9-191. REMOVAL - 115/28 VAC TRANSFORMER.

a. Ensure all electrical power is OFF.

b. Disconnect wiring from transformer and cover wire ends. Tag wires for proper identification.

c. Remove mounting screws and lift transformer from compartment.

#### 9-192. REPAIR - 115/28 VAC TRANSFORMER.

Repair is limited to tightening or properly installing any loose or improperly installed mounting hardware. Replace transformer if damaged.

#### 9-193. INSTALLATION - 115/28 VAC TRANSFORMER.

a. Ensure all electrical power is OFF.

b. Position transformer in compartment and secure with mounting screws.

c. Remove cover from wire ends and connect tagged wires to transformer.

#### 9-194. REFERENCE TRANSFORMER.

#### 9-195. DESCRIPTION - REFERENCE TRANSFORMER.

The reference transformer (3T1) furnishes various reference voltages (0.5, 5, 10, 26, and 115 Vac) required by the armament subsystems. The 115 Vac input and output power is routed through a receptacle mounted on the transformer. **E M** The reference transformer transforms 115 Vac, 400 Hz, 3 phase wye to 115 Vac, 400 Hz 3 phase delta.

#### 9-196. CLEANING - REFERENCE TRANSFORMER.

a. Remove moisture and loose dirt with a clean, soft cloth.

### WARNING

**Cleaning solvent is flammable and toxic. Provide adequate ventilation. Avoid prolonged breathing of solvent vapors and contact with skin or eyes.**

b. Remove grease, fungus, and ground-in dirt with a clean, lint-free cloth dampened with dry cleaning solvent (C112).

### 9-197. INSPECTION - REFERENCE TRANSFORMER.

- a. Inspect transformer for broken contact pins.
- b. Inspect transformer case for damage.
- c. Inspect for damaged insulation between contact pins.
- d. Check for discoloration that would indicate internal shorting or excessive overload.
- e. Check for security of mounting.

### 9-198. ADJUSTMENT - REFERENCE TRANSFORMER.

No adjustment can be made.

### 9-199. REMOVAL - REFERENCE TRANSFORMER.

- a. Ensure all electrical power is OFF.
- b. Disconnect electrical connector from transformer. Protect receptacle and plug with cap or electrical tape (C121).
- c. Remove mounting screws and lift transformer from compartment.

### 9-200. REPAIR - REFERENCE TRANSFORMER.

Repair is limited to tightening or properly installing any loose or improperly installed mounting hardware. Replace transformer if damaged.

### 9-201. INSTALLATION - REFERENCE TRANSFORMER

- a. Ensure all electrical power is OFF.
- b. Position transformer in compartment and secure with mounting screws.
- c. Remove protective cap or electrical tape from electrical connector and connect to transformer.

### 9-202. POWER FACTOR CORRECTION CAPACITOR.

### 9-203. DESCRIPTION - POWER FACTOR CORRECTION CAPACITOR.

The power factor correction capacitor (3C1) and (3C2) balances voltage and current for correct and efficient operation of the instruments. (Refer to paragraph 9-16.)

### 9-204. ENGINE VIBRATION METER RECEPTACLE.

### 9-205. DESCRIPTION - ENGINE VIBRATION METER RECEPTACLE.

The engine vibration meter receptacle (3J1) is powered from the 115 Vac bus, and used as a source of 115 Vac power for the vibration meter during engine vibration tests. It is also used as a convenient point to monitor ac voltage from the 115 Vac essential bus during functional tests or troubleshooting.

### 9-206. **E M** ALTERNATOR ALTERNATOR CONTROL UNIT

### 9-207. **E M** DESCRIPTION -- ALTERNATOR CONTROL UNIT.

The alternator control unit (3VR1) regulates the ac terminal voltage of the alternator by varying dc excitation voltage and controls the alternator.

### 9-208. **E M** CLEANING - ALTERNATOR CONTROL UNIT.

- a. Remove moisture and loose dirt with a clean, soft cloth.

## WARNING

Cleaning solvent is flammable and toxic. Provide adequate ventilation. Avoid prolonged breathing of solvent vapors and contact with skin or eyes.

- b. Remove grease, fungus, and ground-in dirt with a clean, lint-free cloth, dampened with dry cleaning solvent (C112).

- c. Remove dirt from electrical connectors with a bristle brush.

**9-209. E M INSPECTION INSPECTION - ALTERNATOR CONTROL UNIT.**

- a. Inspect case for cracks or damage.
- b. Inspect electrical connectors for broken pins or cracked connector inserts.
- c. Check for bonding and security of mounting.
- d. Check for faulty operation.

**9-210. E A D J U S T M E N T - ALTERNATOR CONTROL UNIT.**

No adjustment can be made.

**9-211. E R E M O V A L - ALTERNATOR CONTROL UNIT.**

- a. Ensure all electrical power is OFF.
- b. Disconnect electrical connector from alternator control unit. Protect receptacle and Plug with caps or electrical tape (C121).
- c. Remove mounting screws, washers, and nuts. Remove alternator control unit from helicopter.

**9-212. E R E P A I R - ALTERNATOR CONTROL UNIT.**

Repair connectors, and replace any missing mounting screws.

**9-213. E M I N S T A L L A T I O N - ALTERNATOR CONTROL UNIT.**

- a. Ensure all electrical power is OFF.
- b. Position alternator control unit in helicopter and install mounting screws, washers, and nuts.
- c. Remove caps or electrical tape from plugs and receptacles.
- d. Connect electrical connector to the alternator control unit.

**9-214. E M I N V E R T E R R E M O T E CONTROL CIRCUIT BREAKER.**

**9-215. F M D E S C R I P T I O N - INVERTER REMOTE CONTROL CIRCUIT BREAKER.**

The inverter remote control circuit breaker (3CB7) is used as a remote controlled switch. When energized, 28 Vdc is routed from the power transfer bus through essential relay (2K9) to the inverter (3PS1). (Refer to paragraph 9-14).

**9-216. E A C C O N T R O L R E L A Y .**

**9-217. E M D E S C R I P T I O N D E S C R I P T I O N - AC CONTROL RELAY.**

The ac control relay (3K2) is used as a double-pole, double throw remote controlled switch. When deenergized, the relay opens the ground for the TRU remote control circuit breaker (3CB6). When energized, the relay connects transformer rectifier unit (3PS2), through the TRU remote control circuit breaker (3CB6), ac source relay (3K1), and current transformer (3T3) to the alternator (3G1), when alternator switch (3S1) is ON. (Refer to paragraph 9-16).

**9-218. E A C S O U R C E R E L A Y .**

**9-219. E M D E S C R I P T I O N D E S C R I P T I O N - AC SOURCE RELAY.**

The ac source relay (3K1) is a four-pole, double throw remote controlled switch. When de-energized, the relay connects the ac loads to inverter (3PS1). When energized, the relay connects ac loads to alternator (3G1). (Refer to paragraphs 9-16).

**9-220. E C U R R E N T TRANSFORMER.**

**9-221. E M D E S C R I P T I O N - CURRENT TRANSFORMER.**

The current transformer (3T3) monitors phase relationship and frequencies at the alternator, and assures that proper voltages and frequencies are furnished to the ac distribution system.

**9-222. E M C L E A N I N G - CURRENT TRANSFORMER.**

- a. Remove moisture and loose dirt with a clean, soft cloth.

**WARNING**

Cleaning solvent is flammable and toxic. Provide adequate ventilation. Avoid prolonged breathing of solvent vapors and contact with skin or eyes.

b. Remove grease, fungus, and ground-in dirt with a clean, lint-free cloth dampened with dry cleaning solvent (C112).

**9-223. E M INSPECTION - CURRENT TRANSFORMER.**

- a. Inspect transformer for broken contact pins.
- b. Inspect transformer case for damage.
- c. inspect for damaged insulation between pins.
- d. Check for discoloration that would indicate internal shorting or excessive overload.
- e. Check for security of mounting.

**9-224. E M ADJUSTMENT - CURRENT TRANSFORMER.**

No adjustment can be made.

**9-225. E M REMOVAL - CURRENT TRANSFORMER.**

- a. Ensure all electrical power is OFF.
- b. Disconnect electrical connector from transformer. Protect receptacle and plug with cap or electrical tape (C121).
- c. Remove mounting screws and lift transformer from compartment.

**9-226. E M REPAIR - CURRENT TRANSFORMER.**

Repair is limited to tightening or properly installing any loose or improperly installed mounting hardware. Replace transformer if damaged.

**9-227. F M INSTALLATION - CURRENT TRANSFORMER.**

- a. Ensure all electrical power is OFF.

b. Position transformer in compartment and secure with mounting screws.

c. Remove protective cap or electrical tape from plug and receptacle.

d. Connect electrical connector to the transformer.

**9-228. E M TRANSFORMER-RECTIFIER UNIT.**

**9-229. F M DESCRIPTION - TRANSFORMER-RECTIFIER UNIT.**

The transformer-rectifier unit (3PS2) receives 115 Vat, three phase from the alternator (3G1) and changes it to 28 Vdc for TRU bus power.

**9-230. E M CLEANING - TRANSFORMER-RECTIFIER UNIT.**

- a. Remove moisture and loose dirt with a clean, soft cloth.

**WARNING**

Cleaning solvent is flammable and toxic. Provide adequate ventilation. Avoid prolonged breathing of solvent vapors and contact with skin or eyes.

b. Remove grease, fungus, and ground-in dirt with a clean, lint-free cloth dampened with dry cleaning solvent (C112).

**9-231. F M INSPECTION INSPECTION - TRANSFORMER-RECTIFIER UNIT.**

- a. Inspect transformer-rectifier for broken contact pins.
- b. Inspect transformer-rectifier case for damage.
- c. Inspect for damaged insulation between contact pins.
- d. Check for discoloration that would indicate internal shorting or excessive overload.
- e. Check for security of mounting.



**9-232. E M ADJUSTMENT - TRANSFORMER-RECTIFIER UNIT.**

No adjustment can be made.

**9-233. E M REMOVAL - TRANSFORMER-RECTIFIER UNIT.** (Refer to paragraph 9-112).

- a. Deleted.
- b. Deleted.
- c. Deleted.

**9-234. Deleted.**

**9-235. Deleted.**

**9-236. TRU REMOTE CONTROL CIRCUIT BREAKER.**

**9-237. E M DESCRIPTION - TRU REMOTE CONTROL CIRCUIT BREAKER.**

The TRU (transformer-rectifier unit) remote control circuit breaker (3CB6) is used as a remote controlled switch. By placing alternator switch (3S1) to ON, TRU remote control circuit breaker (3CB6) is energized, supplying power to transformer-rectifier unit (3PS2). (Refer to paragraph 9-8.)

**SECTION IV. STARTING SYSTEM**

**9-238. STARTING SYSTEM.**

**9-239. DESCRIPTION - STARTING SYSTEM.**

The starting system requires 24 Vdc power to activate the starter portion of the starter-generator during the starting cycle. The 24 Vdc power source maybe either from the external power source or battery. The starting system consists of the starter (1MG1), starter relay (1K3), and starter switch (1S36).

**9-240. FUNCTIONAL TEST - STARTING SYSTEM.**

a. Disconnect wires K4B4 and K4D4 from terminal C of the starter-generator. Close STARTER RELAY circuit breaker. Actuate starter switch (1S36) on pilot collective stick and check that starter relay

(1K3) closes, and that voltage is present at the ends of the disconnected wires.

- b Open STARTER RELAY circuit breaker (1CB7).
- c. Reconnect wires K4B4 and K4D4 after check.

**9-241. TROUBLESHOOTING - STARTING SYSTEM.**

Refer to paragraph F-9 in Appendix F for wiring diagram. Use table 9-10 and perform checks as necessary to isolate trouble. In the following table, tripped circuit breakers are omitted from indications of trouble. Such trouble is usually easily detected and corrected. Broken wiring is always a probable cause of circuit malfunction or failure and has not been included

NOTE

Before you use this table, be sure you have performed all normal operational checks. If You have a malfunction which is not listed in this table, notify the next higher level of maintenance.

Table 9-10. Troubleshooting Starting System

---

CONDITION

TEST OR INSPECTION

**CORRECTIVE ACTION**

1. Starter fails to operate when start switch is depressed.

STEP 1. Determine if START REL circuit breaker (1CB7) is defective.

**Replace circuit breaker if defective (paragraph 9-23).**

STEP 2. Determine if starter switch (1S36) is defective.

**Replace starter switch if defective (paragraph 9-16).**

STEP 3. With starter switch depressed, ensure that actuating voltage is present on terminal X1 and ground potential is present on terminal X2 of starter relay (1K3). Determine if relay actuates.

**Replace starter relay if defective (paragraph 9-16).**

STEP 4. Determine if starter-generator brushes are excessively worn.

**Replace brushes if worn excessively (paragraph 9-79).**

STEP 5. Determine if starter-generator armature is burned out.

**Replace starter-generator if defective (paragraph 9-79).**

2. Starter fails to produce sufficient rpm during start cycle.

STEP 1. Determine if power source is producing sufficient current.

**Use fully charged battery or connect an external power source.**

STEP 2. Determine if starter-generator armature bearings are excessively worn.

**Replace starter-generator if defective (paragraph 9-79).**

STEP 3. Determine if malfunction is caused by excessive friction or hang up in engine or drive train.

Shutdown and correct mechanical malfunction.

**9-242. STARTER.**

**9-243. DESCRIPTION - STARTER.**

The starter-generator (1MG1) is located on the underside of the engine. This unit is used to start the engine, charge the battery, and supply power for operation of dc equipment. (Refer to paragraphs 9-79 through 9-85 for maintenance procedures.)

**9-244. STARTER RELAY.**

**9-245. DESCRIPTION - STARTER RELAY.**

The starter-relay (1K3) is an electrically operated switch between the main bus bar and the starter-generator. It is energized when the starter switch (1S36) on the pilot collective stick is pressed. (Refer to paragraphs 9-18 through 9-22 for maintenance procedures.)

**SECTION V. IGNITION SYSTEM**

**9-246. IGNITION SYSTEM.**

**9-247. DESCRIPTION - IGNITION SYSTEM.**

The ignition system is energized during the starting cycle and controls fuel flow into the power plant and initiates ignition in the combustion chamber. A key lock ignition switch (1S39) is installed on left side of pilot instrument panel. The ignition system consists of the igniter pack and the engine primer solenoid valve.

**9-248. FUNCTIONAL TEST - IGNITION SYSTEM.**

- a. Disconnect starter wires K4B4 and K4D4.
- b. Close IGN SOL circuit breaker. Position FUEL switch (1S33) on pilot engine control panel and key lock ignition switch (1S39) to ON. Actuate pilot starter

switch (1S36) on pilot collective stick and check that ignition unit and primer solenoid valve both operate.

- c. Position FUEL switch (1S33) to OFF. Actuate pilot STARTER switch (1S36) and check that neither the ignition nor the solenoid valve operates.

- d. Reconnect starter wires K4B4 and K4D4.

**9-249. TROUBLESHOOTING - IGNITION SYSTEM.**

Refer to paragraph F-9 in Appendix F for wiring diagram. Use Table 9-11 and perform checks as necessary to isolate trouble. In the following table, tripped circuit breakers are omitted from indications of trouble. Such trouble is usually easily detected and corrected. Broken wiring is always a probable cause of circuit malfunction or failure and has not been included.

**NOTE**

**Before you use this table, be sure you have performed all normal operational checks. If you have a malfunction which is not listed in this table, notify the next higher level of maintenance.**

**Table 9-11. Troubleshooting Ignition System**

---

CONDITION

TEST OR INSPECTION

**CORRECTIVE ACTION**

1. Igniter or primer valve fails to operate when starter switch (1S36) is depressed.

Table 9-11. Troubleshooting Ignition System (Cont)

CONDITION

TEST OR INSPECTION

**CORRECTIVE ACTION**

STEP 1. Determine that starter switch (1S36) contacts are not corroded or burned.

**If starter switch (1S36) contacts are corroded or burned, replace switch (paragraph 9-16).**

STEP 2. Determine that key lock ignition switch (1S36) is functional.

**If key lock ignition switch is not functioning properly, replace switch (paragraph 9-16).**

STEP 3. Determine that fuel switch (1S33) is functional.

**If fuel switch is not functioning properly, replace switch (paragraph 9-16).**

STEP 4. Ensure igniter is functioning properly.

**Replace igniter if required in accordance with TM 55-2840-229-23.**

STEP 5. Determine that primer valve is functioning properly,

**If primer valve is not functioning properly, replace valve in accordance with TM 55-2840-229-23.**

**9-250. IGNITER PACK.**

**9-2510 DESCRIPTION - IGNITER PACK.**

Ignition to the power plant is provided by the igniter pack furnished with and attached to the engine. This unit provides a continuous ignition arc during engine start cycle (Refer to TM 55-2840-229-23)

**9-252. ENGINE PRIMER SOLENOID VALVE.**

**9-253. DESCRIPTION - ENGINE PRIMER SOLENOID VALVE.**

The engine primer solenoid valve directs fuel to the starting fuel nozzle during engine start. (Refer to TM 55-2840-229-23).

**SECTION VI. LIGHTING PROVISIONS**

**9-254. LIGHTING PROVISIONS.**

**9-255, DESCRIPTION - LIGHTING PROVISIONS.**

The lighting provisions, include cockpit lights, console, engine, flight, and tactical lights, caution and warning lights systems, position lights, anti-collision light, searchlight, and transmission oil level light systems.

**9-256. COCKPIT LIGHTS.**

**9-257. DESCRIPTION - COCKPIT LIGHTS.**

The cockpit lights (8DS13, 8DS14, and 8DS15) are multi-purpose utility lights designed to selectively provide either red or white (blue- green only after NVG compatibility modification) illumination, utilizing a narrow spotlight beam or a wide floodlight beam and protected by a 5 ampere CKPT LT circuit breaker.

Controls necessary to obtain operational modes of ON-OFF, dim-bright, spot-flood, and red or white illumination are incorporated into the lamp body.

**9-258. CLEANING - COCKPIT LIGHTS.**

Clean cockpit lights in accordance with paragraph 9-18.

**9-259. INSPECTION - COCKPIT LIGHTS.**

Inspect cockpit lights in accordance with paragraph 9-19.

**9-260. FUNCTIONAL TEST - COCKPIT LIGHTS.**

- a. Open all circuit breakers.

- b. Close CKPT LT circuit breaker. Check that pilot and gunner utility lights are operational in each mode (ON-OFF, dim-bright and spot-flood on both red and white).

- c. Open CKPT LT circuit breaker

**9-261. TROUBLESHOOTING - COCKPIT LIGHTS.**

Refer to paragraph F-9 in Appendix F for wiring diagrams. Use Table 9-12 and perform checks as necessary to isolate trouble. In the following table, tripped circuit breakers and burned out bulbs are omitted from indications of trouble. Such trouble is usually easily detected and corrected. Broken wiring is always a probable cause of circuit malfunction or failure and has not been included.

**NOTE**

**Before you use this table, be sure you have performed all normal operational checks. If you have a malfunction which is not listed in this table, notify the next higher level of maintenance.**

**Table 9-12. Troubleshooting Cockpit Lights**

---

CONDITION

TEST OR INSPECTION

**CORRECTIVE ACTION**

- 1. Switch fails to operate lights.

STEP 1. Determine that lighting switch/rheostat is functioning properly.

**If lighting switch/rheostat is not functioning properly, replace light (paragraph 9-16).**

- 2. One light dim or out intermittent.

STEP 1. Check that light is properly grounded.

**If light is not properly grounded, remove light and clean ground.**

STEP 2. Check for corrosion in light socket.

**Clean light socket terminals or replace light if required (paragraph 9-16).**

---

**9-262. REMOVAL - COCKPIT LIGHTS.**

- a. Disengage COCKPIT LT circuit breaker (8CB8).
- b. Remove mounting hardware, lift out light assembly and disconnect light wire.

**9-263. REPAIR-COCKPIT LIGHTS.**

Light assembly may be repaired by replacing damaged or defective component parts. If light case is damaged beyond repair, complete unit must be replaced

**9-264. INSTALLATION - COCKPIT LIGHTS.**

- a. Connect light wire and install light assembly with mounting hardware.
- b. Engage CKPT LT circuit breaker (8CB8) and check light for proper operation.

**9-265. CONSOLE, ENGINE, FLIGHT, AND TACTICAL INSTRUMENT LIGHTS.**

**9-266. DESCRIPTION  
ENGINE, FLIGHT, AND TACTICAL INSTRUMENT LIGHTS.**

The console, engine, flight, and tactical instrument lights are energized by the 28 Vdc Essential Bus and protected by PLT INSTR LT and GNR INSTR LT 5 amp Circuit breakers. Four rheostats (8R10, 8R11, 8R12, and 8R13) mounted on the pilot lighting control panel provide light dimming of the pilot console, engine, flight, and tactical instrument lights. ARC-201 Singars radio internal lighting is controlled by CONSOLE LIGHT rheostat (8R13) and a dimmer control assembly. ~ Two rheostats (8R3 and 8R4) mounted on the gunner miscellaneous control panel provide light dimming of gunner instrument and console lights. Rheostat (8R5) on gunner instrument panel provides dimming of gunner tactical instrument lights. **E M** All three rheostats (8R3, 8R4, and 8R5) are mounted on the gunner instrument panel.

**9-267. CLEANING - CONSOLE, ENGINE, FLIGHT, AND TACTICAL INSTRUMENT LIGHTS.**

Clean lights in accordance with paragraphs 9-18 and 9-32.

**9-268. INSPECTION - CONSOLE, ENGINE, FLIGHT, AND TACTICAL INSTRUMENT LIGHTS.**

Inspect lights in accordance with paragraphs 9-19 and 9-33.

**9-269. FUNCTIONAL TEST - CONSOLE, ENGINE, FLIGHT, AND TACTICAL INSTRUMENT LIGHTS.**

- a. Open all circuit breakers.
- b. Close PLT INSTR LT circuit breaker (8CB6). Rotate FLIGHT instrument lights rheostat (8R11) slightly in a clockwise direction and note that attached switch closes. Continue clockwise rotation. Check that all flight instruments on the pilot instrument panel become illuminated and increase in brightness with clockwise rotation of the rheostat.
- c. Rotate CONSOLE lights rheostat (8R13) clockwise. Check that all control panels in the pilot left and right consoles become illuminated and increase in brightness with rotation of the rheostat. Doppler indicator light dims to fixed in intensity as rheostat is turned from OFF.
- d. Rotate TACTICAL lights rheostat (8R10) in the clockwise direction. Check that all tactical instrument lights on the pilot instrument panel become illuminated and increase in brightness with clockwise rotation of the rheostat.
- e. Rotate ENGINE lights rheostat (8R12) clockwise. Check that all engine instruments become illuminated and increase in brightness with clockwise rotation of the rheostat.
- f. Deleted.
- g. Open PLT INSTR LT circuit breaker.
- h. Close GNR INSTR LT circuit breaker. Rotate gunner INSTR LTS Rheostat (8R3) slightly in a clockwise direction and note that attached switch

closes. Continue clockwise rotation. Check that gunner caution panel, edge-lit panel and all instrument lights on gunner instrument panel become illuminated and increase in brightness with clockwise rotation of the rheostat.

i. Rotate gunner CSL LT Rheostat (8R4) in a clockwise direction. Check that all lights on the gunner console panel become illuminated and increase in brightness with clockwise rotation of the rheostat.

j. Deleted.

k. Open all circuit breakers.

**9-269.1. ADJUSTMENT -- DIMMER CONTROL**

a. Energize AN/ARC-201 and cockpit lighting cur-

cuit breakers.

b. Adjust cockpit instrument lights to maximum brightness.

c. Measure input voltage (Vdc) by connecting positive test lead of multimeter (T2 or equivalent) to terminal 1 of DIM TB1 and negative lead to terminal 3 of DIM TB1. Record voltage and determine corresponding output voltage (Table 9-12.1).

d. Set multimeter to record Vac and connect leads to terminals 3 and 4 of DIM TB1. Loosen dimmer network locking nut and using a screwdriver, adjust dimmer network until multimeter indicates output voltage determined in paragraph 9-269.1.c. Retighten dimmer network locking nut.

TABLE 9-21.1. DIMMER CONTROL INPUT/OUTPUT VOLTAGES

INPUT (VDC)	OUTPUT (VAC)
20	45.5
21	47.5
22	50.0
23	52.5
24	55.0
25	57.5
26	60.0
27	62.5
28	65.0
29	67.5
30	70.0

NOTE

Desired voltage is 28VDC input for 65.0 VAC output.

**9-270. TROUBLESHOOTING - CONSOLE, ENGINE, FLIGHT, AND TACTICAL INSTRUMENT LIGHTS.**

Refer to paragraph F-9 in Appendix F for wiring diagrams. Use Table 9-13 and perform checks as necessary to isolate trouble. In the following table tripped cir-

cuit breakers and burned out bulbs are omitted from indications of trouble. Such trouble is usually easily detected and corrected. Broken wiring is always a probable cause of circuit malfunction or failure and has not been included.





---

**NOTE**

Before you use this table, be sure you have performed all normal operational checks. If you have a malfunction which is not listed in this table, notify the next higher level of maintenance.

**Table 9-13. Troubleshooting Console, Engine, Flight, and Tactical Instrument Lights**

---

**CONDITION****TEST OR INSPECTION****CORRECTIVE ACTION**

1. Rheostat fails to operate lights (on position or dimming).

STEP 1. Determine if rheostat is functioning properly.

**If rheostat is not functioning properly, replace rheostat (paragraph 9-16).**

2. **M** Doppler indicator lights fail to dim or go off when console lights rheostat is turned from OFF.

STEP 1. Determine if relay RP7633G152 is functioning properly.

**If relay RP7633G152 is not functioning propely, replace relay.**

STEP 2. Determine if resistor between 8TB5-B9 and 8TB5-D9 is functional.

**If resistor is faulty, replace resistor.**

---

**9-271. REMOVAL - CONSOLE, ENGINE, FLIGHT, AND TACTICAL INSTRUMENT LIGHTS.**

Remove lights in accordance with paragraph 9-20.

**9-272. REPAIR - CONSOLE, ENGINE, FLIGHT, AND TACTICAL INSTRUMENT LIGHTS.**

Repair lights in accordance with paragraph 9-21.

## 9-273. INSTALLATION - CONSOLE, ENGINE, FLIGHT, AND TACTICAL INSTRUMENT LIGHTS.

Install lights in accordance with paragraph 9-22.

## 9-274. CAUTION LIGHT SYSTEM.

### 9-275. DESCRIPTION - CAUTION LIGHT SYSTEM.

The caution light system includes the pilots and gunners caution panels. The purpose of these units is to provide a visual warning in the event of system malfunctions in the helicopter. The pilots and gunners caution panels (see figures 9-13 through 9-17.1) contain independent lights and internal lamp driver circuits. The lights are arranged in four columns in the pilots caution panel, and three in the gunners panel. Each light has its own unique nomenclature filter and two individual lamps. These illuminate when associated sensor/switches, located in the helicopter to monitor various systems, actuate to complete circuits, indicating malfunctions. The panels are energized from a 28 Vdc essential bus and protected by a 5 ampere CAUT LT circuit breaker located in the pilot dc circuit breaker panel (2A1).

### 9-275.1. FUNCTIONAL TEST - CAUTION LIGHT PANEL.

During the following checks, MASTER CAUTION light on pilots and gunners instrument panels should illuminate each time a caution panel segment illuminates, except for pilot **P** EMER HYDR PUMP ON **E M** EMERG HYD PUMP ON segment, and shall be reset each time in readiness for another fault indication. All checks shall apply to both pilots and gunners caution panels as applicable.

a. Close CAUT LT and **P** GOV CONT **M** GOV CONTR circuit breakers. Check that MASTER CAUTION lights illuminate and that each caution light segment operates as indicated below.

b. Reset MASTER CAUTION light by placing the RESET/TEST switch to RESET and releasing. Check that MASTER CAUTION lights extinguish and the caution light segments remain as indicated in Tables 9-14 and 9-15.

c. Test caution lights by placing the RESET/TEST switch to TEST and releasing. Check that MASTER

CAUTION lights momentarily illuminate brightly and then extinguish and that all caution light segments momentarily illuminate brightly and return to their previous condition.

d. Push BRIGHT/DIM switch to DIM and release. Check that caution lights do not dim.

e. Rotate pilot CONSOLE lights rheostat clockwise from OFF. Place the DIM/BRIGHT switch to DIM and release. Check that the lights dim and hold.

f. Rotate CONSOLE lights rheostat counterclockwise to OFF and check that the lights return to bright.

### 9-276. FUNCTIONAL TEST - CAUTION LIGHT SYSTEM.

a. During the following checks, the MASTER CAUTION lights should illuminate each time a caution panel segment illuminates and shall be reset each time in readiness for another fault indication. All checks shall apply to both pilots and gunners caution panels, as applicable.

b. Accomplish the following caution light circuitry functional test steps in sequence:

(1) Engine Oil Pressure Lights.

(a) Connect a variable pressure tester (TI2), or equivalent, to engine oil pressure switch (1S13) and apply pressure. Check that ENG(INE) OIL PRESS caution lights extinguish at  $27 \pm 1$  psig increasing.

(b) Relieve pressure on engine oil pressure switch. Check that ENG(INE) OIL PRESS caution lights illuminate at 25 psig decreasing.

(2) Transmission Oil Pressure Lights.

(a) Disconnect connector (1S9P1) from transmission oil pressure switch (1S9). Check that **P** XMSN OIL PRESS **M** TRANS OIL PRESS caution lights extinguish.

(b) Apply temporary jumper between pins A and B of connector (1S9P1). Check that **P** XMSN OIL PRESS **E M** TRANS OIL PRESS lights illuminate.

(c) Remove jumper and reconnect connector. Check that **P** XMSN OIL PRESS **E M** TRANS OIL PRESS lights are illuminated.

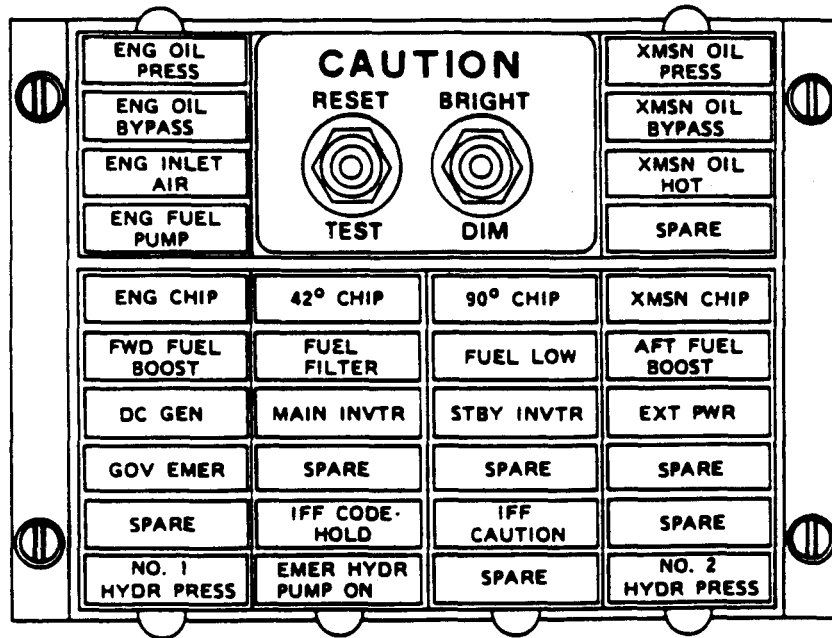

Figure 9-13. **P** Pilot Caution Panel

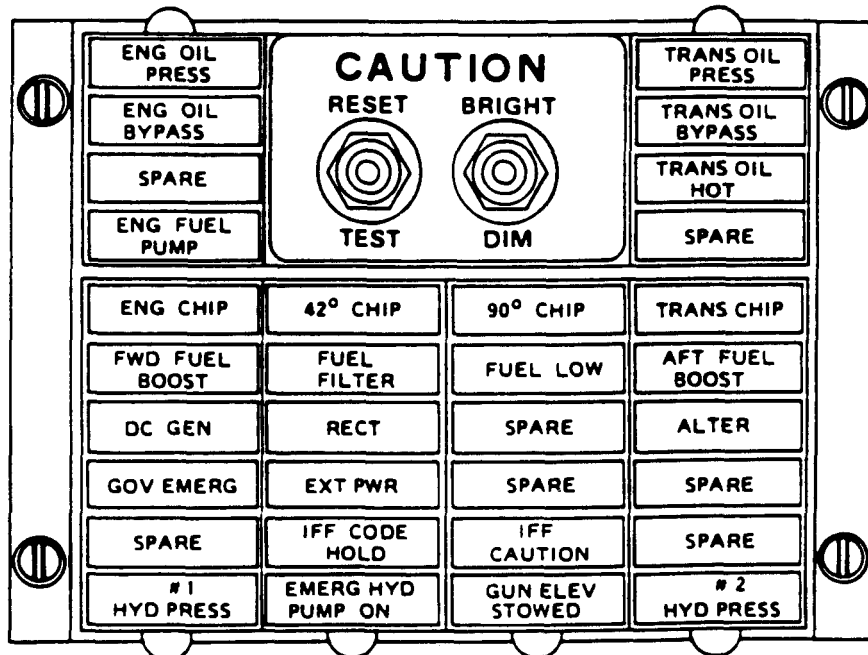

Figure 9-14. **E** Pilot Caution Panel

Page 9-81, including Figure 9-14.1, has been deleted





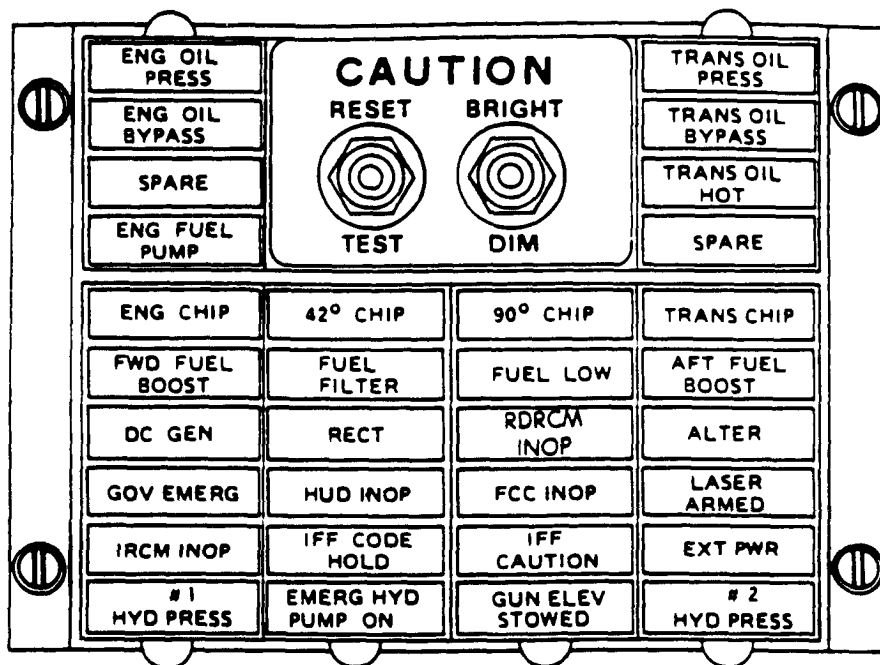

Figure 9-15. **M** Pilot Caution Panel

Figure 9-15.1 - deleted.

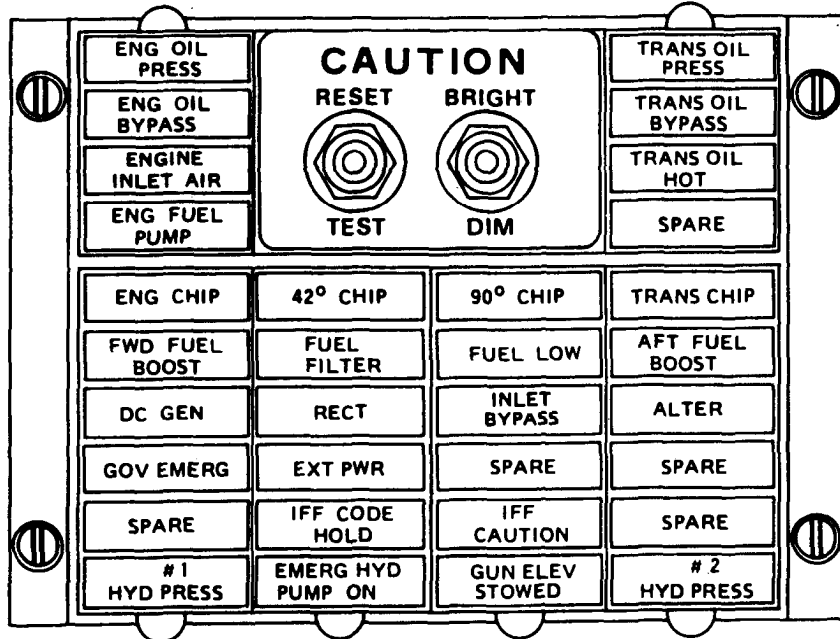

Figure 9-14.1. **E** Pilot Caution Panel (After Incorporation of MWO 55-1520-236-50-12)

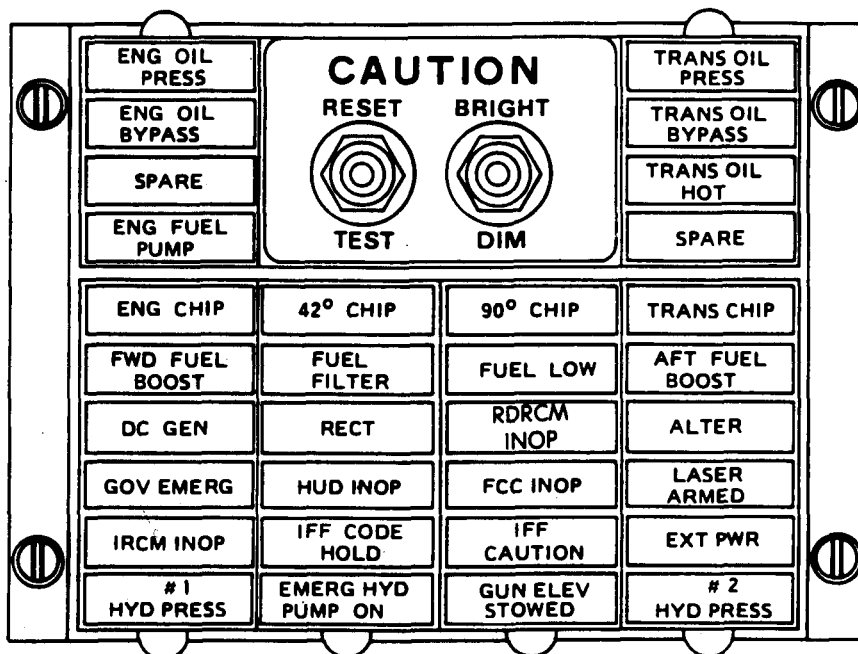

Figure 9-15. \* Pilot Caution Panel (Prior to Incorporation of MWO 55-1520-236-50-12)

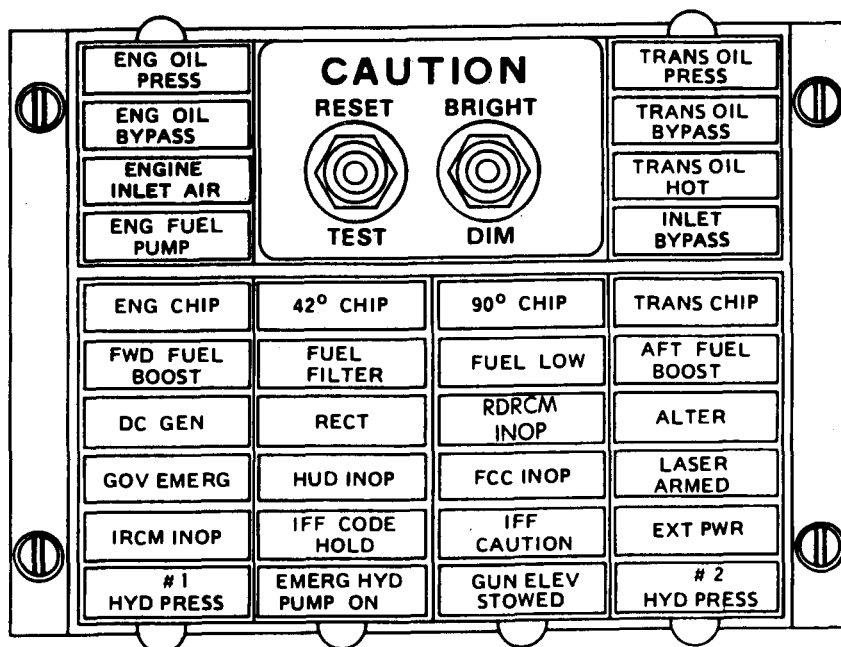

Figure 9-15.1. **M** Pilot Caution Panel  
(After Incorporation of MWO 55-1520-236-50-12)



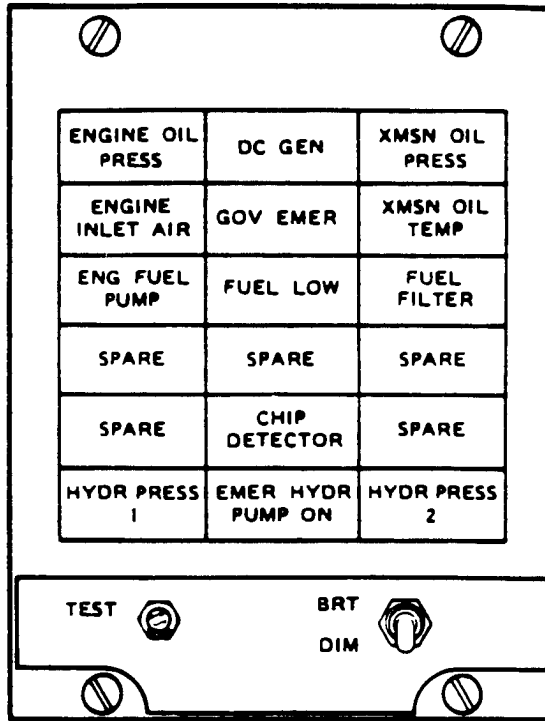

Figure 9-16. **P** Gunners Caution Panel

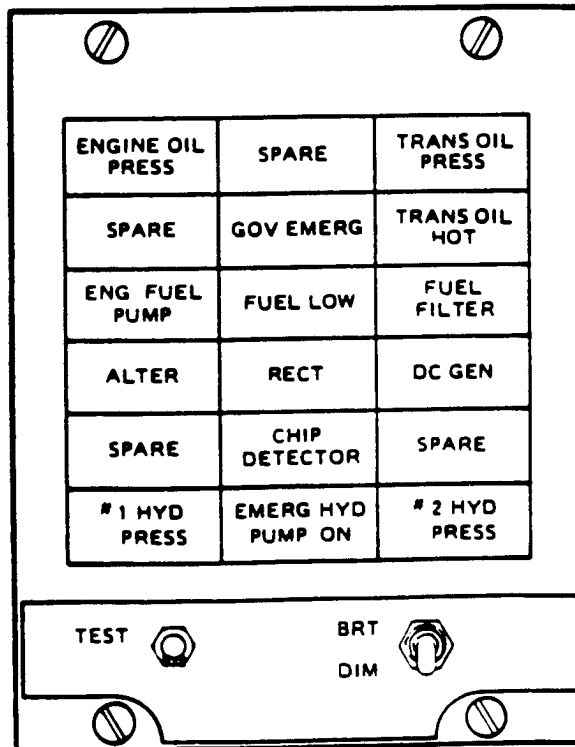

Figure 9-17. **E M** Gunner Caution Panel

Figure 9-17.1- deleted



Table 9-14. Pilots Caution Panel Lights

PILOTS CAUTION PANEL LIGHTS		
Seq. No.	Caution Lights	On/Off Condition
1	ENG OIL PRESS	ON
2	<b>P</b> XMSN OIL PRESS	ON
2	<b>E M</b> TRANS OIL PRESS	ON
3	ENG OIL BYPASS	ON*
4	<b>P</b> XMSN OIL BYPASS	ON
4	<b>E M</b> TRANS OIL BYPASS	ON
5	SPARE	OFF
6	<b>P</b> XMSN OIL HOT	OFF
6	<b>E M</b> TRANS OIL HOT	OFF
7	ENG FUEL PUMP	ON
8	SPARE	OFF
9	ENG CHIP	OFF
10	42° CHIP	OFF
11	90° CHIP	OFF
12	<b>P</b> XMSN CHIP	OFF
12	<b>E M</b> TRANS CHIP	OFF
13	FWD FUEL BOOST	ON
14	FUEL FILTER	OFF
15	FUEL LOW	ON**
16	AFT FUEL BOOST	ON
17	DC GEN	ON
18	<b>P</b> MAIN INVTR	ON
18	<b>E M</b> RECT	ON
19	<b>P</b> STBY INVTR	ON
19	<b>E</b> SPARE	OFF
19	<b>M</b> RDRCM INOP	OFF
20	<b>P</b> EXT PWR	(EITHER)
20	<b>E M</b> ALTER	ON
21	<b>P</b> GOV EMER	OFF
21	<b>E M</b> GOV EMERG	OFF
22	<b>P</b> SPARE	OFF
22	<b>E</b> EXT PWR	(EITHER)
22	<b>M</b> HUD INOP	OFF***
23	<b>P E</b> SPARE	OFF
23	<b>M</b> FCC INOP	OFF***
24	<b>P E</b> SPARE	OFF
24	<b>M</b> LASER ARMED	OFF***
25	<b>P E</b> SPARE	OFF
25	<b>M</b> IRCM INOP	OFF ***
26	IFF CODE HOLD	OFF
27	IFF CAUTION	OFF
28	<b>P E</b> SPARE	OFF
28	<b>M</b> EXT PWR	(EITHER)
29	<b>P</b> NO. 1 HYDR PRESS	ON
29	<b>E M</b> #1 HYD PRESS	ON
30	<b>P</b> EMER HYDR PUMP ON	OFF
30	<b>E M</b> EMERG HYD PUMP ON	OFF

Table 9-14. Pilots Caution Panel Lights-Continued

PILOTS CAUTION PANEL LIGHTS		
Seq. No.	Caution Lights	On/Off Condition
31	<b>P</b> SPARE	OFF
31	<b>E M</b> GUN ELEV STOWED	OFF
32	<b>P</b> NO. 2 HYDR PRESS	ON
32	<b>E M</b> #2 HYD PRESS	ON

\* Light is illuminated if not sufficient oil level in engine.  
 \*\* Light is illuminated if fuel level is low.  
 \*\*\* System assumed to be on.

Table 9-15. Gunners Caution Panel Lights

GUNNERS CAUTION PANEL LIGHTS		
Seq. No.	Caution Light	On/Off Condition
1	ENGINE OIL PRESS	ON
2	SPARE	OFF
3	ENG FUEL PUMP	ON
4	<b>P</b> SPARE	OFF
4	<b>E M</b> ALTER	ON
5	SPARE	OFF
6	<b>P</b> HYDR PRESS #1	ON
6	<b>E M</b> #1 HYD PRESS	ON
7	<b>P</b> DC GEN	ON
7	<b>E M</b> SPARE	OFF
8	<b>P</b> GOV EMER	OFF
8	<b>E M</b> GOV EMERG	OFF
9	FUEL LOW	ON*
10	<b>P</b> SPARE	OFF
10	<b>E M</b> RECT	ON
11	CHIP DECTECTOR	OFF
12	<b>P</b> EMER HYDR PUMP ON	OFF
12	<b>E M</b> EMERG HYD PUMP ON	OFF
13	<b>P</b> XMSN OIL PRESS	ON
13	<b>E M</b> TRANS OIL PRESS	ON
14	<b>P</b> XMSN OIL TEMP	OFF
14	<b>E M</b> TRANS OIL HOT	OFF
15	FUEL FILTER	OFF
16	<b>P</b> SPARE	OFF
16	<b>E M</b> DC GEN	ON
17	SPARE	OFF
18	<b>P</b> HYDR PRESS #2	ON
18	<b>E M</b> #2 HYD PRESS	ON

\* Light is illuminated if fuel level is low.

NOTE

Operate engine in accordance with TM 55-1520-236-10.

(d) Perform run-up to check transmission oil pressure switch (1S9) pressure actuation.

(3) Engine Oil Bypass Light.

(a) Accomplish the following for empty oil tank condition.

1 Disconnect wire W84D18 from terminal 1 of terminal board (1TB5). Check that ENG OIL BYPASS caution light on pilot caution panel extinguishes.

2 Reconnect wire W84D18 on terminal 1 of terminal board (1TB5). Check that ENG OIL BYPASS light on pilot caution panel illuminates.

(b) Accomplish the following for oil in tank condition:

1 Temporarily place a jumper wire between terminals 1 and 2 on terminal board (1TB5). Check that ENG OIL BYPASS caution light is illuminated.

2 Remove jumper wire and check that ENG OIL BYPASS caution light is again extinguished.

(4) Transmission Oil Bypass Light.

(a) Disconnect wire W70B20 from transmission oil bypass switch (1S10). Check that **P** XMSN OIL BYPASS **E M** TRANS OIL BYPASS caution light extinguishes.

(b) Temporarily connect wire W70B20 to ground. Check that **P** XMSN OIL BYPASS **E M** TRANS OIL BYPASS caution light illuminates.

(c) Reconnect wire W70B20 to transmission oil bypass switch (1S10). Check that **P** XMSN OIL BYPASS **E M** TRANS OIL BYPASS caution light illuminates.

(5) Transmission Oil Hot Lights.

(a) Connect stud on top of transmission oil temperature switch (1S8) to ground and check that pilot **P** XMSN OIL HOT **E M** TRANS OIL HOT and **P**

gunner XMSN OIL TEMP **E M** TRANS OIL HOT caution lights illuminate.

(b) Remove ground from transmission oil temperature switch (1S8) and check that both caution lights extinguish.

(6) Engine Fuel Pump Lights.

**CAUTION**

Do not allow electrical wires to make contact with each other or with helicopter structure (ground).

(a) Disconnect wires W71D18 and W71E18 from forward fuel pressure switch (1S12) terminal on left hand side of the engine. Check that both pilots and gunners ENG FUEL PUMP caution lights are extinguished.

(b) Temporarily connect wires W71D18 and W71E18 to each other, but do not permit electrical contact with forward fuel pressure switch terminal or ground. Check that both pilot and gunner ENG FUEL PUMP caution lights are illuminated.

(c) Reconnect wire W71D18 to forward fuel pressure switch (1S12) terminal, but leave wire W71E18 disconnected. Check that both pilot and gunner ENG FUEL PUMP caution lights are illuminated.

(d) Reconnect wire W71E18 to forward fuel pressure switch (1S12) terminal, thus returning the wiring to its normally installed position. Check that both ENG FUEL PUMP caution lights are illuminated.

(7) Engine Chip Light.

(a) Short engine chip detector (1E4) output wire (W10C18) to ground. Check that ENG CHIP light on pilot caution panel (8A2) illuminates.

(b) Check that CHIP DETECTOR light on gunner caution panel (8A3) illuminates.

(8) 42° Chip Light.

(a) Short 42° chip detector (1E1) output wire (W8C20) to ground. On helicopters with MWO 1-1520-236-50-30 (ODDS), short pin 1 of chip detector cable plug to ground. Check that 42° CHIP light on pilot caution panel illuminates.

(b) Check that CHIP DETECTOR light on gunner caution panel illuminates.

(9) 90° Chip Light.

(a) Short 90° chip detector (1E2) output wire (W9C20) to ground. On helicopters with MWO 1-1520-236-50-30, short pin 1 of chip detector cable plug to ground.

(b) Check that CHIP DETECTOR light on gunners caution panel illuminates.



**(10) Transmission Chip Light.**

(a) Short transmission chip detector (1E3) output wire (W7C20) to ground. On helicopters with MWO 1-1520-236-50-30, short pin 1 of debris monitor cable plug to ground. Check that the **XMSN CHIP E M TRANS CHIP** light on pilot caution panel illuminates.

(b) Check that CHIP DETECTOR light on gunners caution panel illuminates.

**(11) Forward Fuel Boost Light.****NOTE**

Fuel boost caution lights tests may be performed simultaneously with low fuel level tests.

(a) Disconnect plug (1S4P1) on fuel manifold valve. Check that FWD FUEL BOOST caution light extinguishes.

(b) Reconnect plug. Check that FWD FUEL BOOST caution light is illuminated.

**(12) Fuel Filter Lights.**

(a) Disconnect plug (1S14P1) from fuel filter bypass switch (1S14). Short pin A to pin B and check that both FUEL FILTER caution lights illuminate.

(b) Remove short from between pins A and B of plug (1S14P1) and check that FUEL FILTER caution lights extinguish. Reconnect plug.

**(13) Fuel Low Light.**

(a) Accomplish the following for low fuel level condition, 215 pounds or less: change second paragraph of note to: If there is low fuel in tanks, low level switches (1S18 and 1S19) will be closed and both pilot's and gunner's fuel low caution lights will illuminate when aircraft is nose down at 7 degrees, gauge indication will read 216-234 pounds (actual fuel 209 pounds).

**NOTE**

This test and fuel boost caution lights tests may be performed simultaneously if desired. If there

is low fuel in tanks, approximately 33 gallons, with nose down at 7 degrees, gage indication will read 225 pounds (actual fuel 209 pounds) or less. Low level switches (1S18 and 1S19) will be closed and both pilots and gunners FUEL LOW caution lights will be illuminated.

1 Disconnect plug (1S4P1) from forward fuel boost pressure switch (1S4) and plug (IS5P1) from aft fuel boost pressure switch (1S5). Check that both FUEL LOW caution lights remain illuminated.

2 Disconnect wire W34A22 from terminal 4 of terminal board (1TB6). Check that both FUEL LOW caution lights extinguish.

3 Reconnect plug (IS4P1) to forward fuel boost pressure switch (1S4). Check that both FUEL LOW caution lights illuminate.

4 Disconnect plug (IS4P1) from forward fuel boost pressure switch (1S4). Check that both FUEL LOW caution lights are extinguished.

5 Connect plug (1S5P1) to aft fuel boost pressure switch (1S5). Check that both FUEL LOW caution lights are illuminated.

6 Disconnect plug (1S5P1). Check that both FUEL LOW caution lights are extinguished.

7 Reconnect wire W34A22 to terminal 4 on terminal (1TB6). Check that both FUEL LOW caution lights are illuminated.

8 Disconnect wire W36A22 from terminal 3 of terminal board (1TB7). Check that both FUEL LOW caution lights are extinguished.

9 Connect plug (1S4P1) to forward fuel boost pressure switch (1S4). Check that both FUEL LOW caution lights are illuminated.

10 Disconnect plug (1S4P1). Check that both FUEL LOW caution lights are extinguished.

11 Reconnect wire W36A22 to terminal 3 of terminal board (1TB7). Check that both FUEL LOW caution lights are illuminated.

12 Disconnect wire W37C22 from terminal 4 of terminal board (1TB7). Check that both FUEL LOW caution lights are extinguished

13 Connect plugs (1S4P1 and 1S5P1). Check that FUEL LOW caution lights do not illuminate.

14 Reconnect wire W37C22 to terminal 4 of terminal board (1TB7). Check that both FUEL LOW caution lights are illuminated.

15 visually check that plugs (1S4P1 and 1S5P1) and wires W37C22, W36A22, and W34A22 are properly reinstalled on their proper receptacles and terminals. Check that each connection is tight and secure.

(b) Accomplish the following procedure for fuel in tanks, 235 pounds or greater.

NOTE

If the tanks have more than 236 pounds of fuel, when aircraft is nose down at 7 degrees low level switches (1S18 and 1S19) Will be open and both pilot's gunner's fuel low caution lights will be extinguished.

1 Disconnect wire W37C22 from terminal 4 of terminal board (1TB7) and temporarily connect the wire to ground. Check that both FUEL LOW caution lights illuminate.

2 Remove wire W37C22 from ground and reconnect to terminal 4 of terminal board (1TB7). Check that FUEL LOW caution lights are extinguished.

3 Remove wire W34A22 from terminal 4 of terminal board (1TB6) and temporarily connect to ground. Check that FUEL LOW caution lights are illuminated

4 Remove wire W34A22 from ground and reconnect to terminal 4 of terminal board (1TB6). Check that FUEL LOW caution lights are extinguished.

(14) Aft Fuel Boost Light.

NOTE

Fuel boost caution lights test may be performed simultaneously with low fuel level tests.

(a) Disconnect plug (1S5P1) on fuel manifold valve. Check that AFT FUEL BOOST caution light extinguishes.

(b) Reconnect plug. Check that AFT FUEL BOOST caution light is illuminated.

(15) DC Generator Lights. The DC GEN caution lights are checked as apart of the dc generator system. (Refer to paragraphs 9-73 or 9-77.)

(16) **P** Main Inverter. The MAIN INVTR caution light is checked as a part of the main inverter system. (Refer to paragraph 9-133.)

(17) **P** Standby Inverter. The STBY INVTR caution light is checkd as a part of the main inverter and standby inverter system. (Refer to paragraph 9-150.)

(18) **E M** Rectifier Lights.

(a) Disconnect wire P17K20N from 2JB1 -B7. Check that both RECT lights extinguish.

(b) Reamed wire P17K20N to 2JB1-B7. Check that both RECT lights illuminate.

(19) **E M** Alternator Lights.

(a) Disconnect wire X61A22N from air-frame structure. Check that both ALTER caution lights extinguish.

(b) Reconnect wire X61A22N. Check that both ALTER caution lights illuminate.

(20) Governor Emergency Lights.

(a) Verify that **P** GOV CONT **E M** GOV CONTR circuit breaker (1CB5) is dosed. Position GOV switch (1S32) on pilot ENGINE control panel and GOV switch (1S28) on gunner miscellaneous panel to AUTO. Check that both **P** GOV EMER **E M** GOV EMERG caution lights extinguish.

(b) Place GOV switch on pilot control panel to EMER. Check that both **P** GOV EMER **E M** GOV EMERG caution lights illuminate.

(c) Return GOV switch on pilot control panel to AUTO. Check that both **P** GOV EMER **E M** GOV EMERG caution lights extinguish.



**(21) M HUD INOP Light.**

(a) Close FCC and HUD PWR circuit breakers. Turn HUD power on. Check that HUD INOP caution light is not illuminated.

(b) Open HUD PWR circuit breaker, check that HUD INOP caution light illuminates.

**(22) M FCC INOP Light.**

(a) Place battery switch to run. Close REF XFER circuit breaker on AC/ARMT circuit breaker panel.

(b) Close FCC circuit breaker. Check that FCC INOP caution light is not illuminated.

(c) Remove wire A1112A22N from airframe ground. Check that FCC INOP caution light illuminates.

**NOTE**

Wire is located in local grounds behind front cross tube on right hand side of aircraft.

(d) Connect wire A1112A22N to airframe ground. Check that FCC INOP caution light does not illuminate.

**(23) M LASER ARMED Light.** The LASER ARMED caution light is functionally tested as a part of the M65 TOW missile subsystem. (Refer to paragraph 9-524.)

**(24) M IRCM INOP Light.** The IRCM INOP caution light is functionally tested as part of the IR counter measure function test. (Refer to TM 11-1520-236-series manuals.)

**(25) IFF CODE HOLD Light.** The IFF CODE HOLD caution light is functionally tested as part of the IFF system. (Refer to TM 11-1520-236 series maintenance manuals.)

**(26) IFF CAUTION Light.** IFF caution light is functionally tested as part of the IFF system. (Refer to TM 11-1520-236 series maintenance manuals.)

**(27) External Power Light.**

(a) Position P BAT E M BATTERY switch (2S1) to P ON E M RUN. Open external power access door and check that EXT PWR caution light on pilots caution panel illuminates.

(b) Close external power access door and check that EXT PWR caution light is extinguished.

**(28) No. 1 Hydraulic Pressure Lights.**

(a) Apply external hydraulic pressure to hydraulic system No. 1 and check that pilot P NO. 1 HYDR PRESS E M #1 HYD PRESS and gunners P HYDR PRESS #1 E M #1 HYD PRESS caution lights extinguish at 800 ± 100 psig increasing pressure.

(b) Relieve pressure applied to hydraulic system NO. 1 and check that both pilots P NO. 1 HYDR PRESS E M #1 HYD PRESS and gunners P HYDR PRESS #1 E M #1 HYD PRESS caution lights illuminate at 500 ± 100 psig decreasing pressure.

**(29) Emergency Hydraulic Pump Lights.**

(a) Remove plug (1S20P1) from emergency hydraulic pressure switch (1S20). Connect jumper wire from pin C to pin B of plug (1S20P1) (ground). Check that both P EMER HYDR PUMP ON E M EMERG HYD PUMP ON lights illuminate.

(b) Remove jumper cable. Check that both P EMER HYDR PUMP ON E M EMERG HYD PUMP ON lights extinguish.

**(30) No. 2 Hydraulic Pressure Lights.**

(a) Apply external hydraulic pressure to hydraulic system No. 2 and check that pilots P NO. 2 HYDR PRESS E M #2 HYD PRESS gunners P HYDR PRESS #2 E M #2 HYD PRESS caution lights illuminate at 500\* 100 psig decreasing pressure.

**(31) E M Gun Elevation Stowed Light.**

**NOTE**

Refer to TM 55-1520-236-10 for turret operation Information.

(a) Move turret from stowed position. Check that GUN ELEV STOWED light on pilots caution panel extinguishes.

(b) Move turret to stowed position. Check that GUN ELEV STOWED light on pilots caution panel illuminates.

(32) **E M** Engine Inlet Air Light.

(a) Disconnect plug (1S101P1) from differential pressure switch (1S101). Short pin A to pin B and check that both pilot and gunner ENGINE AIR INLET caution lights illuminate.

(b) Remove short between pins A and B of plug (1S101P1) and check that ENGINE AIR INLET caution lights extinguish. Reconnect plug.

(33) **E M** Inlet Bypass Light.

(a) Disconnect plug (1A50P1) from bypass door actuator (1A50). Short pin D to pin C and check that both pilot and gunner INLET BYPASS caution lights illuminate.

(b) Remove short between pins D and C of plug (1A50P1) and check that INLET BYPASS caution lights extinguish. Reconnect plug.

**9-276.1. PILOTS CAUTION PANEL.****9-277. DESCRIPTION - PILOTS CAUTION PANEL.**

There are eight lamp driver circuit boards in the pilot caution panel. Each circuit board drives four circuits for a total of 32 light positions. Five of the circuit boards (P/N 81-1886-1) contain all negative (ground) fault apply input circuits. Another board (P/N 81-1886-7) also contains all negative (ground) fault apply inputs, while circuit board (P/N 81-1886-3) contains three negative (ground) fault apply input circuits and one positive (+28 Vdc) circuit. Circuit board (P/N 81-1886-5) has two negative (ground) and two positive (+28 Vdc) fault apply circuits. The BRT/DIM, RESET/TEST and master caution circuitry are contained on circuit board (P/N 81-1888-1). Circuit board (P/N 81-1884-1) is an interconnection printed circuit board between the lamp driver boards and the indicator lamp circuits. There are no active components on the board. Refer to paragraph 9-274 for system description and system functional testing.

a. Refer to schematic figure FO-23.1. The all negative fault apply circuit boards (P/N 81-1886-1 & -7) receive their fault signals through connector J1 at the back of the unit. This signal (for each typical circuit) is routed through internal wiring to the circuit board edge connector. It passes through diodes CR3, CR4 and resistor R2 to the base of NPN transistor Q1. In the bright mode of operation, a positive signal voltage is also received across CR 1 and R 1 to Q1's base. Q1 conducts and provides a path through CR4 and CR3 for the negative (ground) fault apply to light the indicator lamps. The lamps receive +28 Vdc through pin J1-r. In the dim mode of operation, the fault signal (ground) is shunted around Q1 through resistor R5. This extra resistance causes the indicator lamps to light dimly. The negative fault is also felt across R3 and CR6 in each circuit. (CR6 is absent in one circuit board P/N 81-1886-7. This allows an advisory indicator to light without lighting the master caution indicator.) This master caution signal is fed out edge connector pin 15 to edge connector pin 6 on circuit card P/N 81-1888-1. When the RESET/TEST switch SW1 is placed to RESET, +28 Vdc from pin 6 of SW1 is applied through pin 3 of the circuit board edge connector. This signal passes through CR5 and R6 to SCR1. When SCR1 fires, a positive voltage is felt across CR6 of the master caution circuit instead of a negative voltage. When RESET/TEST SW1 is placed to TEST, a ground is supplied

from SW1-3 through pin 8 of the circuit board edge connector. This acts the same as the negative fault described earlier which lights the indicator lamps.

b. The three negative, one positive fault apply circuit board (P/N 81-1886-3) processes its negative fault apply signals in the same manner as described for circuit board (P/N 81-1886-1). The one positive fault apply circuit receives +28 Vdc through connector J1-1. It is routed through wiring to edge connector pin 1 on the circuit board. CR10 and R12 provide the route to the + input of op amp U1. This positive signal overcomes the voltage reference level set by semiconductor zener diode VR 1. This causes U1 to output a positive voltage to the base of NPN transistor Q2, which forward biases Q2. This, in turn, provides a path to ground through CR4 and CR7, brightly lighting the indicator lamps through Q1 if the BRT/DIM switch SW2 is in the BRT position. If SW2 is in the DIM position, ground is provided through resistor R5 causing the lamps to light dimly. The BRT/DIM signal from edge connector pin 17 of circuit board (P/N 81-1888-1) passes through internal wiring to edge connector pin 5 of circuit board (P/N 81-1886-3). The signal continues across CR1 and R1 to the base of NPN transistor Q1. When the positive apply fault is also present, Q1 is forward biased. Its conduction provides a path to ground for the indicator lamps causing them to light. When the BRT/DIM switch is in the DIM position, the indicator lamps find their ground across current limiting resistor R5 which causes the lamps to light dimly. The presence of the positive apply fault is also felt at the junction of CR7 and R3 as a low voltage. CR6 conducts this out edge connector pin 15, through internal wiring to pin 6 of circuit board (P/N 81-1888-1) edge connector. The master caution and the RESET functions for the negative apply fault circuits operate the same as described previously for circuit boards (P/N 81-1886-1 & -7). When the TEST/RESET switch SW1 is placed in the TEST position, ground from SW1-2 is routed through internal wiring to pin 8 of circuit board (P/N 81-1886-3) edge connector. CR12 and R11 pass the signal to the base of PNP transistor Q3. Q3 conducts and provides a path for the +28 Vdc at its collector to pass on through CR11 and R12 to the + input of op amp U1. The operation of the circuit from this point on is the same as that for the positive apply fault.

c. The two negative and two positive fault apply circuits on circuit board (P/N 81-1886-5) operate in the same manner as those described earlier, with the following exception: Positions 26 and 30 will not

activate the master caution circuitry when a fault is applied. Diode CR6 has been removed from that circuit on the board. This allows an aviation green lens to be illuminated in an advisory manner to inform the aircrew of a non-critical situation.

d. The circuit board (P/N 81-1888-1) contains circuitry for BRT/DIM, master caution and TEST functions. When the BRT/DIM switch SW2 is in the BRT position, relays K2 and K1 are de-energized. When the relays are de-energized, +28 Vdc is applied through pin 18 of the edge connector, across the contacts of the relay, and out pin 17 of the edge connector. This voltage enters pin 5 of each circuit card edge connector and lights the indicator lamps in the bright mode as described previously. Relay K1 provides ground to an external function. When the BRT/DIM switch is in the DIM position, relays K2 and K1 are energized. The bright function is removed from the circuit boards, and the external dimming is removed also. Ground is provided to relays K1 and K2 through contact 4 of SW2, and +28 Vdc is applied through contact 1 and edge connector pin 16. The +28 Vdc through pin 8 latches the relays in the energized position. When RESET/TEST switch SW1 is placed in the TEST position, ground is provided from J1-m through SW1 and on through pins 8 of each circuit board edge connector. The ground is also routed through edge connector pin 1 of circuit board (P/N 81-1888-1), and on through CR3 and R1 to the base of PNP transistor Q1. Q1, which had been reversed biased by pull-up resistor R2, now conducts, which in turn drives PNP transistor Q2 into conduction. This provides a path for the +28 Vdc at the collector of Q2 to pass through diodes CR1 and CR2 out through edge connector pins 4 and 5, and on out through J1-s and t (TEST OUTPUTS). The RESET function does not pass through this circuit board. When the indicator positions (except position 26) illuminate, the master caution signals from the circuit boards are received through edge connector pin 6, and are passed through R6 to the base of PNP transistor Q4 forcing it into conduction. This lowers the voltage at pull-up resistor R4 which, in turn, forward biases Q3 into conduction. The +28 Vdc is conducted through Q3 and CR4 out pin 9 of the edge connector and J1-q as master caution light output. The zener diode VR1 regulates the voltage in the unit.

#### 9-277.1. REMOVAL - PILOTS CAUTION PANEL.

a. Loosen fasteners and lift caution panel from instrument panel.

b. Disconnect electrical connector from the rear of unit.

#### 9-278. BENCH TESTING - PILOTS CAUTION PANEL.

Bench testing procedures consist of connecting the external electrical connections to connector J1 as shown in figure FO-23.1, and then supplying the fault inputs as specified and checking for the correct results. To do this, proceed as follows:

a. Make ground connections to connector J1-p, -k, and -m.

b. Connect +28 Vdc to connector J1-r, -n, and -j.

c. Check that the edge lit panel is lit by all three lamps.

d. Momentarily place the TEST/RESET switch to the TEST position. All 32 positions shall illuminate to full brightness.

e. Check BRIGHT/DIM operation:

(1) Hold the TEST/RESET switch in the TEST position, and close the external ground switch. All 32 positions shall remain brightly illuminated.

(2) Momentarily place the BRIGHT/DIM switch to DIM. All 32 positions shall reduce in illumination and remain dim after the switch is released.

(3) Momentarily place the BRIGHT/DIM switch to BRIGHT. All 32 positions brightly illuminate.

(4) Repeat step (2), then open the external ground switch. All 32 positions shall brightly illuminate.

f. One at a time, check lamp driver circuits by connecting a simulated fault input. Refer to figure FO-23.1 for type and pin number. Only the corresponding position shall illuminate in each case.

#### NOTE

**The external master caution light shall illuminate (multimeter reads +28 Vdc) when one or more of the individual panel lights (except positions 26 and 30) are illuminated.**

**9-278.1. TROUBLESHOOTING - PILOTS CAUTION PANEL.**

g. Monitor J1-q with a voltmeter. Supply a simulated fault input on any one fault circuit pin. Measure +28 Vdc on the multimeter (the master caution light shall illuminate). Momentarily place the TEST/RESET switch to the RESET position, then release. Measure 0 Vdc on the multimeter (the master caution light shall extinguish), but the individual position light shall remain illuminated.

**NOTE**

**Before you use this table, be sure you have performed all operational checks.**

**Table 9-15.1. Troubleshooting - Pilots Caution Panel**

CONDITION
<p>TEST OR INSPECTION</p> <p><b>CORRECTIVE ACTION</b></p> <p>1. Edge lit panel fails to illuminate.</p> <p>STEP 1. Substitute known good lamps.</p> <p><b>If lamps are defective, install serviceable lamps. (Refer to paragraph 9-279 and 9-281.)</b></p> <p>STEP 2. Check for corrosion in lamp socket.</p> <p><b>If required, clean lamp socket terminals or replace lamp. (Refer to paragraph 9-18.)</b></p> <p>2. All 32 positions fail to illuminate during lamp TEST.</p> <p>STEP 1. Test operation of circuits with multimeter.</p> <p><b>If TEST switch or wiring is damaged or defective, replace as required.</b></p> <p>3. During lamp TEST, one position is dim only.</p> <p>STEP 1. Substitute two known good lamps.</p> <p><b>If one of two lamps is defective, replace with serviceable lamp.</b></p> <p>STEP 2. Check for corrosion in lamp socket.</p> <p><b>If required, clean lamp socket terminals or replace lamp. (Refer to paragraph 9-18.)</b></p> <p>STEP 3. Substitute a known good printed circuit board in circuit. (Refer to paragraph 9-279 and 9-281.)</p> <p><b>If problem is solved, replace defective printed circuit board with a serviceable one.</b></p> <p>4. During lamp TEST, one position does not illuminate.</p> <p>STEP 1. Using multimeter, ensure lamp is properly grounded.</p> <p><b>If lamp is not properly grounded, remove lamp and clean ground. (Refer to paragraph 9-18.)</b></p>

Table 9-15.1. Troubleshooting - Pilot Caution Panel (Cont)

---

**CONDITION****TEST OR INSPECTION****CORRECTIVE ACTION**

STEP 2. Check for corrosion in lamp socket.

**If required, clean lamp socket terminals or replace lamp. (Refer to paragraph 9-18.)**

5. On lamp TEST, external master caution light does not illuminate.

STEP 1. Check BRIGHT/DIM control on printed circuit board (P/N 81-1888-1) for proper transistor switching.

**If transistor switching is incorrect, replace defective components on printed circuit board. (Refer to paragraph 9-12.)**

6. Master caution lamp fails to illuminate with one individual position illuminated.

STEP 1. Substitute a known good printed circuit board for printed circuit board that drives that lamp position.

**If known good printed circuit board corrects problem, install a serviceable printed circuit board for that position. (Refer to paragraph 9-279 and 9-281.)**

7. With one individual position illuminated, master caution lamp fails to extinguish when TEST/RESET switch is placed to RESET.

STEP 1. Substitute a known good printed circuit board for printed circuit board that drives that lamp position.

**If known good printed circuit board corrects problem, install a serviceable printed circuit board for that position. (Refer to paragraph 9-279 and 9-281.)**

8. One side, or adjacent positions fail to illuminate.

STEP 1. Check for defective wiring with multimeter.

**If wiring is defective, repair or replace. (Refer to paragraph 9-11.)**

STEP 2. Substitute a known good interconnection printed circuit board (paragraph 9-279) in unit.

**If that corrects problem, install a serviceable interconnection printed circuit board in unit. (Refer to paragraph 9-279.)**

9. All lamps fail to dim or return to bright.

STEP 1. Check for defective wiring with multimeter.

**If wiring is defective, repair or replace. (Refer to paragraph 9-11.)**

Table 9-15.1. Troubleshooting - Pilots Caution Panel (Cont)

CONDITION
<p>TEST OR INSPECTION</p> <p><b>CORRECTIVE ACTION</b></p> <p>STEP 2. Check test setup connection and position of external ground input switches.</p> <p><b>Refer to figure FO-23.1 for proper connections and position of switch.</b></p> <p>STEP 3. Check for proper operation of BRIGHT/DIM switch with a multimeter.</p> <p><b>If switch is defective, replace with a serviceable switch. (Refer to paragraph 9-12.)</b></p> <p>STEP 4. Substitute a known good BRIGHT/DIM printed circuit board in unit.</p> <p><b>If that corrects problem, install a serviceable BRIGHT/DIM printed circuit board in unit. (Refer to paragraph 9-279 and 9-281.)</b></p>
<p>10. Printed circuit board (34, figure 9-17.2) fails to operate.</p> <p>STEP 1. Check printed circuit board for cracks, distortion, or burnt circuit tracks.</p> <p><b>If any damage is found, replace printed circuit board.</b></p> <p>STEP 2. Check components for cracks, broken leads, signs of overheating, or other physical damage.</p> <p><b>If any components are damaged, replace them. (Refer to paragraph 9-280.1.)</b></p> <p>STEP 3. Check for loose, broken, or "cold" solder joints using a multimeter.</p> <p><b>If any defective solder joints are found, repair them. (Refer to paragraph 9-280.1.)</b></p> <p>STEP 4. Use a multimeter to check components for electrical shorts or open circuits.</p> <p><b>If defective components are found, replace them. (Refer to paragraph 9-280.1.)</b></p>
<p>11. Printed circuit board (35, figure 9-17.2) fails to operate.</p> <p>STEP 1. Check printed circuit board for cracks, distortion, or burnt circuit tracks.</p> <p><b>If any damage is found, replace printed circuit board.</b></p> <p>STEP 2. Check components for cracks, broken leads, signs of overheating, or other physical damage.</p> <p><b>If any components are damaged, replace them. (Refer to paragraph 9-280.1.)</b></p> <p>STEP 3. Check for loose, broken, or "cold" solder joints using a multimeter.</p> <p><b>If any defective solder joints are found, repair them. (Refer to paragraph 9-280.1.)</b></p>



Table 9-15.1. Troubleshooting - Pilots Caution Panel (Cont)

## CONDITION

## TEST OR INSPECTION

**CORRECTIVE ACTION**

STEP 4. Use a multimeter to check components for electrical shorts or open circuits.

**If defective components are found, replace them. (Refer to paragraph 9-280.1.)**

12. Printed circuit board (36, figure 9-17.2) fails to operate.

STEP 1. Check printed circuit board for cracks, distortion, or burnt circuit tracks.

**If any damage is found, replace printed circuit board.**

STEP 2. Check components for cracks, broken leads, signs of overheating, or other physical damage.

**If any components are damaged, replace them. (Refer to paragraph 9-280.1.)**

STEP 3. Check for loose, broken, or "cold" solder joints using a multimeter.

**If any defective solder joints are found, repair them. (Refer to paragraph 9-280.1.)**

STEP 4. Use a multimeter to check components for electrical shorts or open circuits.

**If defective components are found, replace them. (Refer to paragraph 9-280.1.)**

13. Printed circuit board (37, figure 9-17.2) fails to operate.

STEP 1. Check printed circuit board for cracks, distortion, or burnt circuit tracks.

**If any damage is found, replace printed circuit board.**

STEP 2. Check components for cracks, broken leads, signs of overheating, or other physical damage.

**If any components are damaged, replace them. (Refer to paragraph 9-280.1.)**

STEP 3. Check for loose, broken, or "cold" solder joints using a multimeter.

**If any defective solder joints are found, repair them. (Refer to paragraph 9-280.1.)**

STEP 4. Use a multimeter to check components for electrical shorts or open circuits.

**If defective components are found, replace them. (Refer to paragraph 9-280.1.)**

14. Printed circuit board (20, figure 9-1 7.2) fails to operate.

STEP 1. Check printed circuit board for cracks, distortion, or burnt circuit tracks.

**If any damage is found, replace printed circuit board.**

Table 9-15.1. Troubleshooting - Pilots Caution Panel (Cont)

CONDITION

TEST OR INSPECTION

**CORRECTIVE ACTION**

STEP 2. Check components for cracks, broken leads, signs of overheating, or other physical damage.

**If any components are damaged, replace them. (Refer to paragraph 9-280.1.)**

STEP 3. Check for loose, broken, or "cold" solder joints using a multimeter.

**If any defective solder joints are found, repair them. (Refer to paragraph 9-280.1.)**

STEP 4. Use a multimeter to check components for electrical shorts or open circuits.

**If defective components are found, replace them. (Refer to paragraph 9-280.1.)**

**9-279. DISASSEMBLY - PILOTS CAUTION PANEL.**

**NOTE**

**Perform steps a, b, and c only when these parts must be replaced. These steps are not required for other disassembly steps, for example, removing a printed circuit board.**

**Perform disassembly procedures only as required to accomplish repair.**

**a.** Remove light indicating panel (13, figure 9-17.1) by removing two screws (14).

**b.** To remove cap assemblies (1), lift up slightly while pulling outward on lever (45, figure 9-17.2). To remove cap assemblies (7, figure 9-17.1), pull down slightly while pulling outward.

**c.** Disassemble cap assemblies (1 and 7) as follows:

(1) With cap assembly (1 or 7) lying face down, lamps (2 or 8) may be removed using a thin, sharp edged instrument or fingernail by prying upward on base ring of each lamp (2 or 8).

(2) Remove lens retainers (3 or 9) to provide access for gray filters (4 or 10), legends (5 or 11), or white filters (6 or 12) replacement. Legends (5 or 11)

and white filters (6 or 12) may be removed by pushing from rear through lamp sockets.

**d.** Remove identification plate (15) from panel subassembly (16) only if damaged or illegible.

**e.** Remove screws (2, figure 9-17.2) and pull toggle switch assembly (1) free from contact assembly (38). Remove screw (3) and lockwasher (4) which attach wire to connector (8).

**f.** Disassemble toggle switch assembly (1) as follows:

(1) Remove knurled nuts (6), lockwashers (7), and toggle switches (5) from switch plate (12).

(2) Remove ferrule nut (9), lockwasher (10), lug terminal (11), and connector (8) from switch plate (12). Do not remove lug terminal (11) from wire unless replacement is required.

(3) Identify, tag, and unsolder wires from each toggle switch (5).

**g.** To gain access to inside of unit, remove six screws (13) from sides and top at rear of housing assembly (59). This will allow cover assembly (65) to swing down as far as wiring will permit.

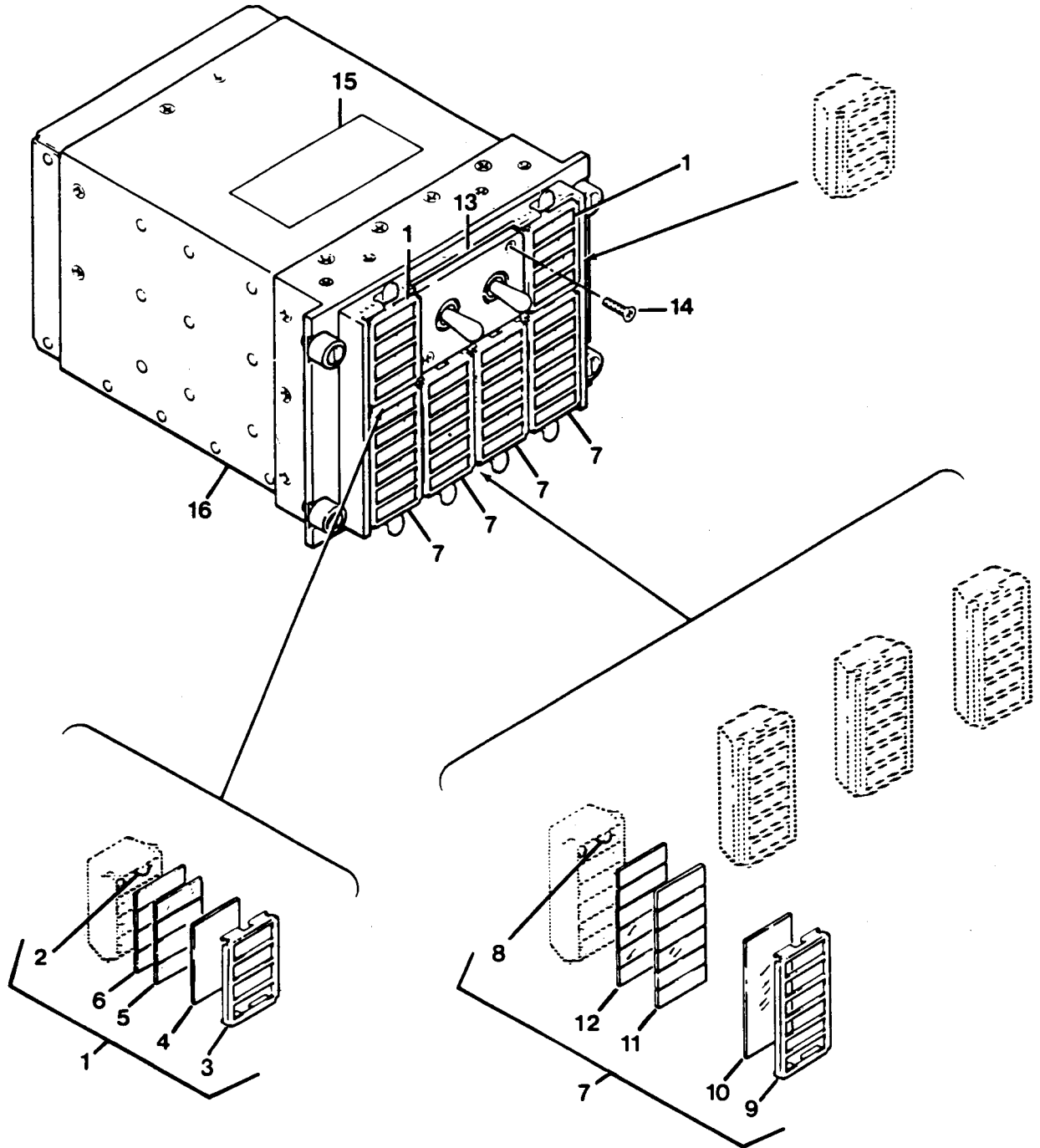

- 1. Cap assembly
- 2. Lamp
- 3. Lens retainer
- 4. Gray filter
- 5. Legend
- 6. White filter

- 7. Cap assembly
- 8. Lamp
- 9. Lens retainer
- 10. Gray filter
- 11. Legend
- 12. White filter

- 13. Light indicating panel
- 14. Screw
- 15. Identification plate
- 16. Panel subassembly

Figure 9-17.2 Pilots Caution Panel Assembly

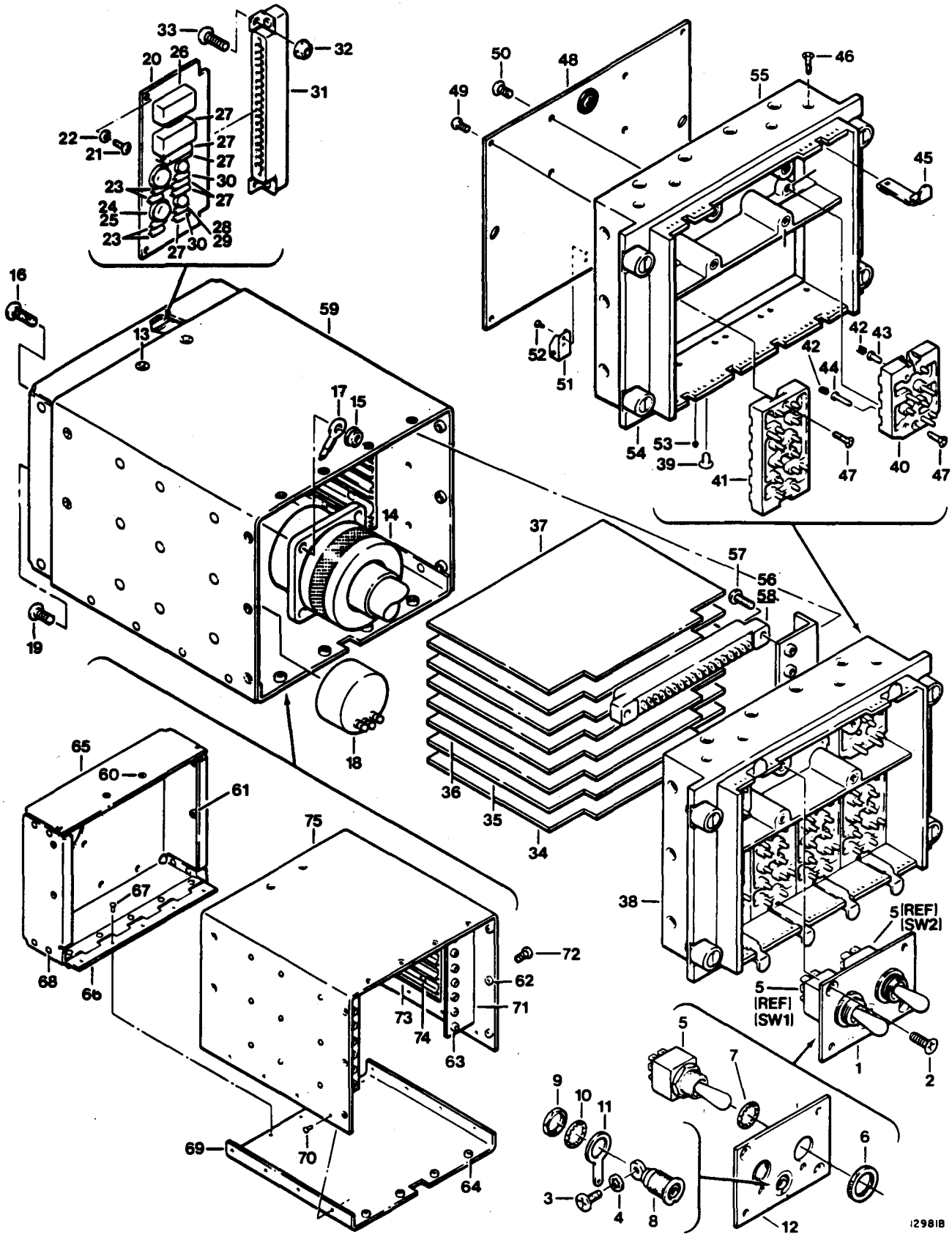

Figure 9-17.3 Pilots Caution Panel Subassembly (Sheet 1 of 2)

- |                           |                           |                            |
|---------------------------|---------------------------|----------------------------|
| 1. Toggle switch assembly | 26. Electrical relay      | 51. Nutplate               |
| 2. Screw                  | 27. Diode                 | 52. Rivet                  |
| 3. Screw                  | 28. Transistor            | 53. Pin                    |
| 4. Lockwasher             | 29. Mounting pad          | 54. Turnlock stud assembly |
| 5. Toggle switch          | 30. Resistor              | 55. Housing                |
| 6. Knurled nut            | 31. Receptacle connector  | 56. Receptacle connector   |
| 7. Lockwasher             | 32. Self-locking nut      | 57. Screw                  |
| 8. Connector              | 33. Screw                 | 58. Polarizing key         |
| 9. Ferrule nut            | 34. Printed circuit board | 59. Housing assembly       |
| 10. Lockwasher            | 35. Printed circuit board | 60. Self-locking nut       |
| 11. Lug terminal          | 36. Printed circuit board | 61. Self-locking nut       |
| 12. Switch plate          | 37. Printed circuit board | 62. Self-locking nut       |
| 13. Screws                | 38. Contact assembly      | 63. Self-locking nut       |
| 14. Connector             | 39. Screw                 | 64. Self-locking nut       |
| 15. Self-locking nut      | 40. Latch base assembly   | 65. Cover assembly         |
| 16. Screw                 | 41. Latch base assembly   | 66. Hinge assembly         |
| 17. Lug terminal          | 42. Spring                | 67. Rivet                  |
| 18. Radio filter          | 43. Contact               | 68. Rivet                  |
| 19. Screw                 | 44. Contact               | 69. Plate assembly         |
| 20. Printed circuit board | 45. Lever                 | 70. Rivet                  |
| 21. Screw                 | 46. Screw                 | 71. Bracket assembly       |
| 22. Lockwasher            | 47. Screw                 | 72. Rivet                  |
| 23. Resistor              | 48. Printed circuit board | 73. Guide                  |
| 24. Transistor            | 49. Screw                 | 74. Rivet                  |
| 25. Disk insulator        | 50. Screw                 | 75. Housing                |

Figure 9-17.3 Pilots Caution Panel Subassembly (Sheet 2 of 2)

**NOTE**

Refer to figures 9-17.3, 9-17.4, FO-23.1 and Table 9-15.1 for wiring information.

h. Remove four self-locking nuts (15) and screws (16), lug terminal (17), and connector (14). Do not remove lug terminal (17) from wire unless replacement is required.

i. Identify and tag wires. Remove pins from connector (14).

j. Identify, tag, and unsolder wires from radio filter (18). Remove screw (19) and radio filter (18).



**Use care when unplugging printed circuit board (20) to prevent damage to components.**

k. Remove two screws (21) and lockwashers (22). Unplug printed circuit board (20) from receptacle connector (31).

l. Remove receptacle connector (31) from cover assembly (65) as follows:

(1) Remove two self-locking nuts (32), screws (33), and receptacle connector (31).

(2) Cut and remove wire ties if required.

(3) Identify, tag, and remove wires from receptacle connector (31).

m. Lower cover assembly (65) far enough to remove printed circuit boards (34 thru 37).



**Use care when unplugging printed circuit boards (34 thru 37) to prevent damage to components.**

n. Using circuit board puller (T90), unplug and tag eight printed circuit boards (34 thru 37).

o. Remove 14 screws (39, figure 9-17.2) and contact assembly (38) from housing assembly (59).

p. Disassemble contact assembly (38) as follows:

**NOTE**

**When latch base assemblies (40 and 41) are removed, loose springs (42) and contacts (43 and 44) will fall free. Ensure none are lost.**

(1) Remove 12 screws (46) from housing (55) and six screws (47) from latch base assemblies (40 and 41).

(2) Lift out latch base assemblies (40) and levers (45) from housing (55). Remove 12 springs (42) and contacts (43).

(3) Lift out latch base assemblies (41) and levers (45) from housing (55). Remove 64 springs (42) and contacts (44).

(4) Identify, tag, and unsolder wires from printed circuit board (48). Refer to figure 9-17.6 for tagging.

(5) Remove screws (49 and 50, figure 9-17.2) and printed circuit board (48) from housing (55).

q. Remove pins (53) from housing (55).

r. Remove turnlock stud assemblies (54) from housing (55).

s. Identify, tag, and unsolder wires from receptacle connectors (56). Remove screws (57) and receptacle connectors (56) from bracket assemblies (71).

t. Remove polarizing keys (58) from receptacle connectors (56). Refer to figure 9-17.7 for location of polarizing keys (58).

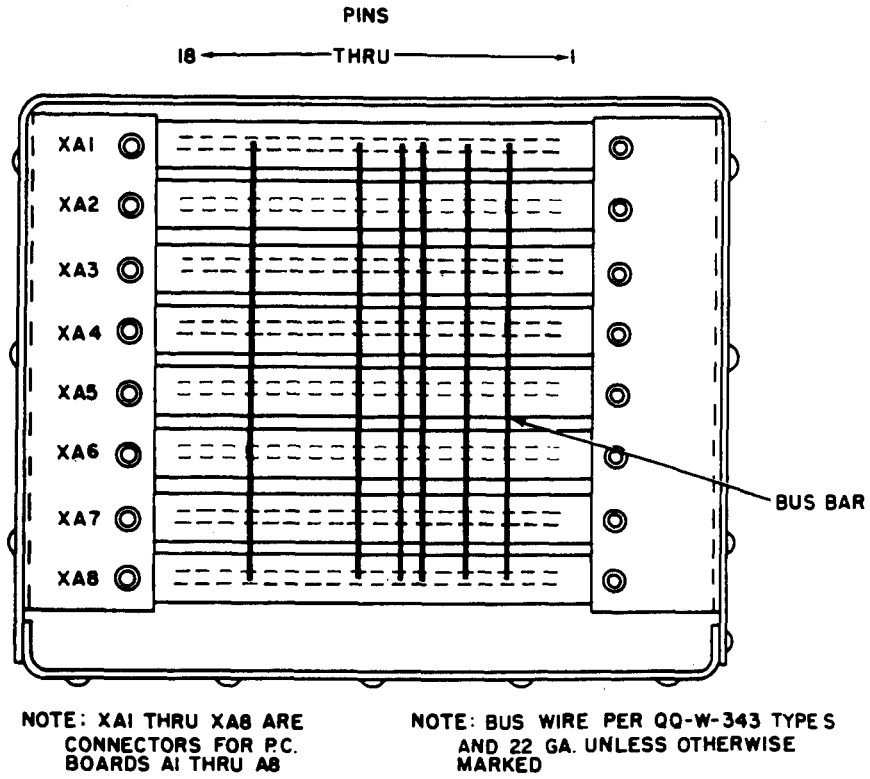

Figure 9-17.4 Housing Subassembly

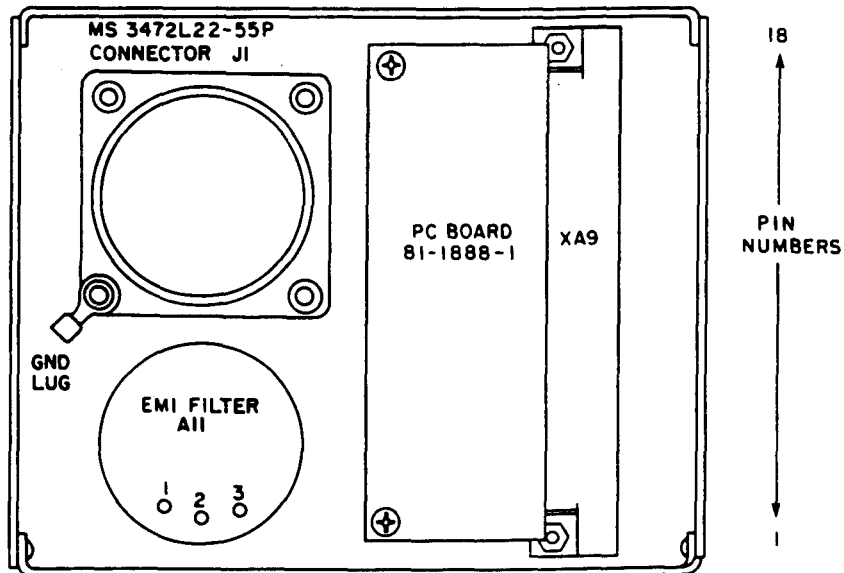
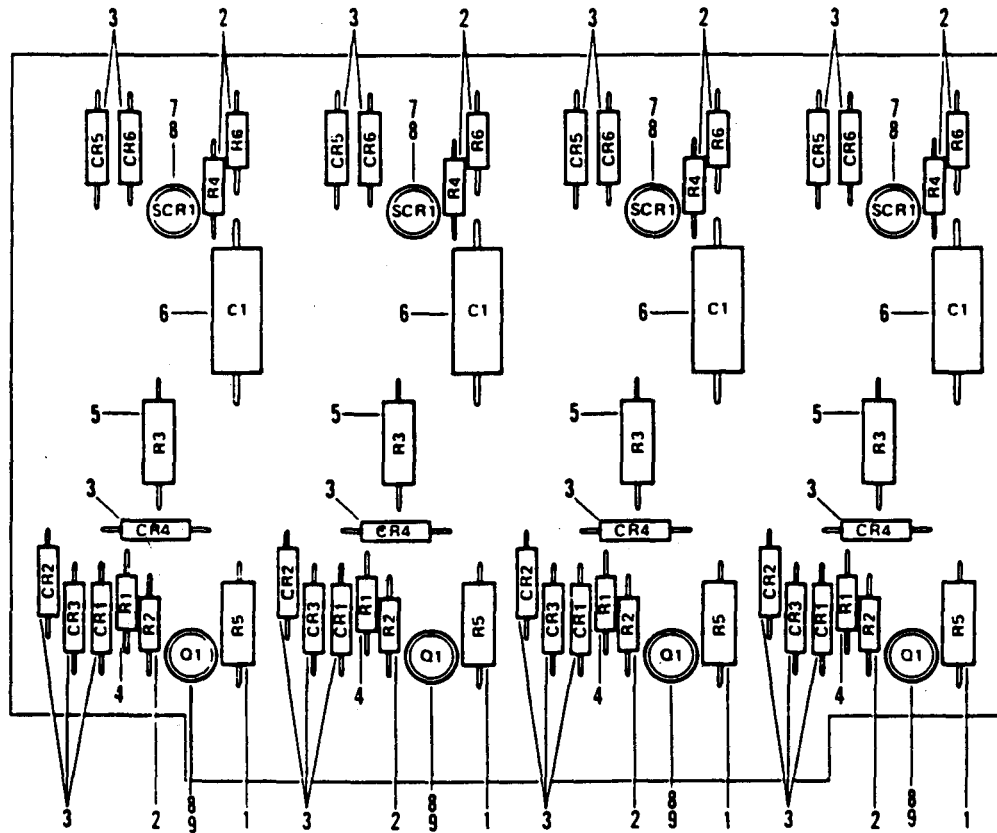

Figure 9-17.5 Cover Assembly

81-1886-1



81-1886-3

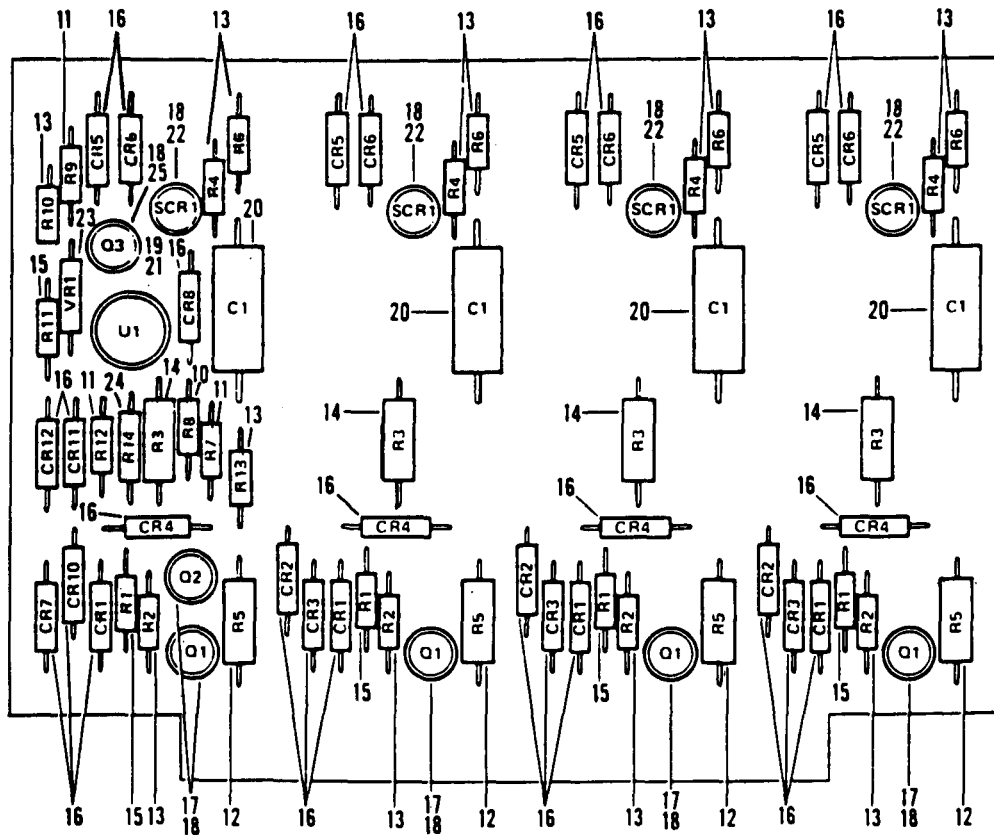
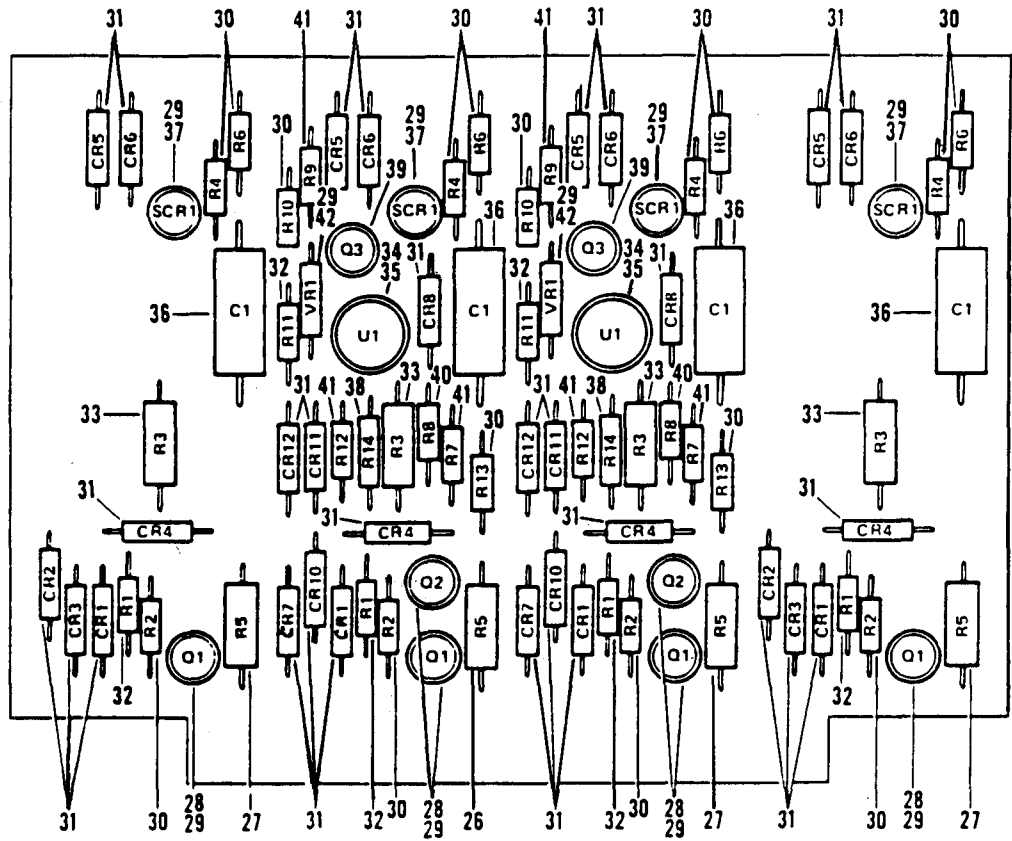

Figure 9-17.6 indicating Light Circuit Card (Sheet 1 of 4)



81-1886-5



81-1886-7

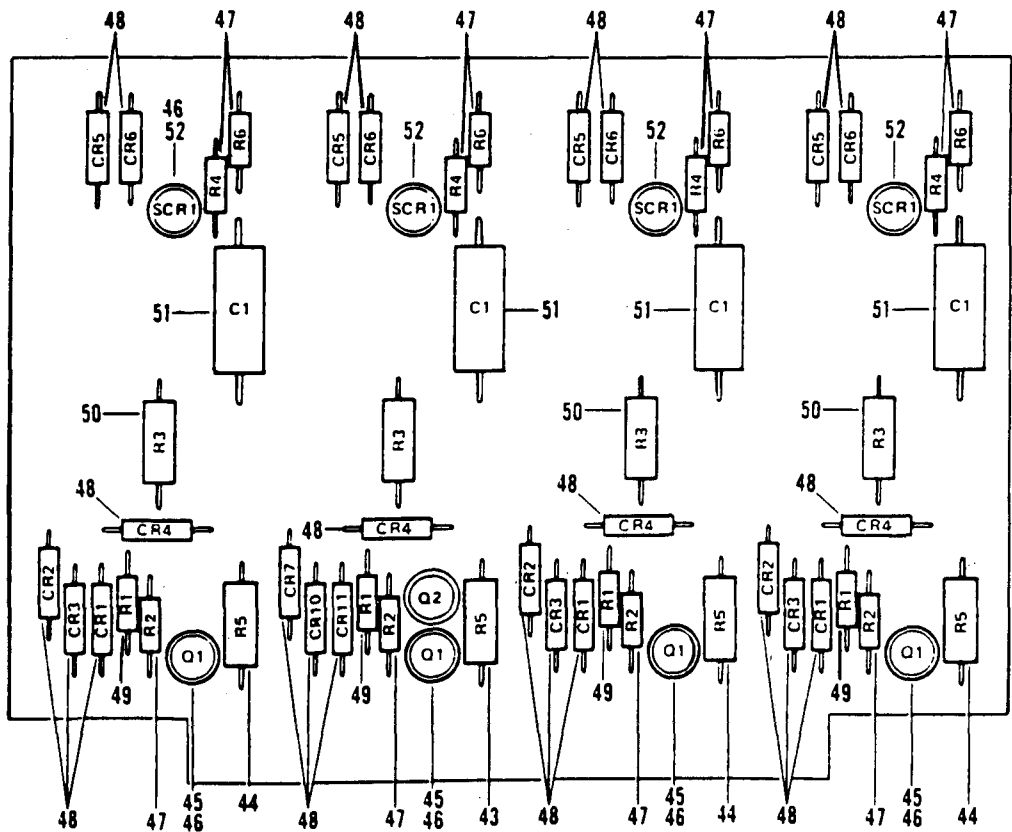
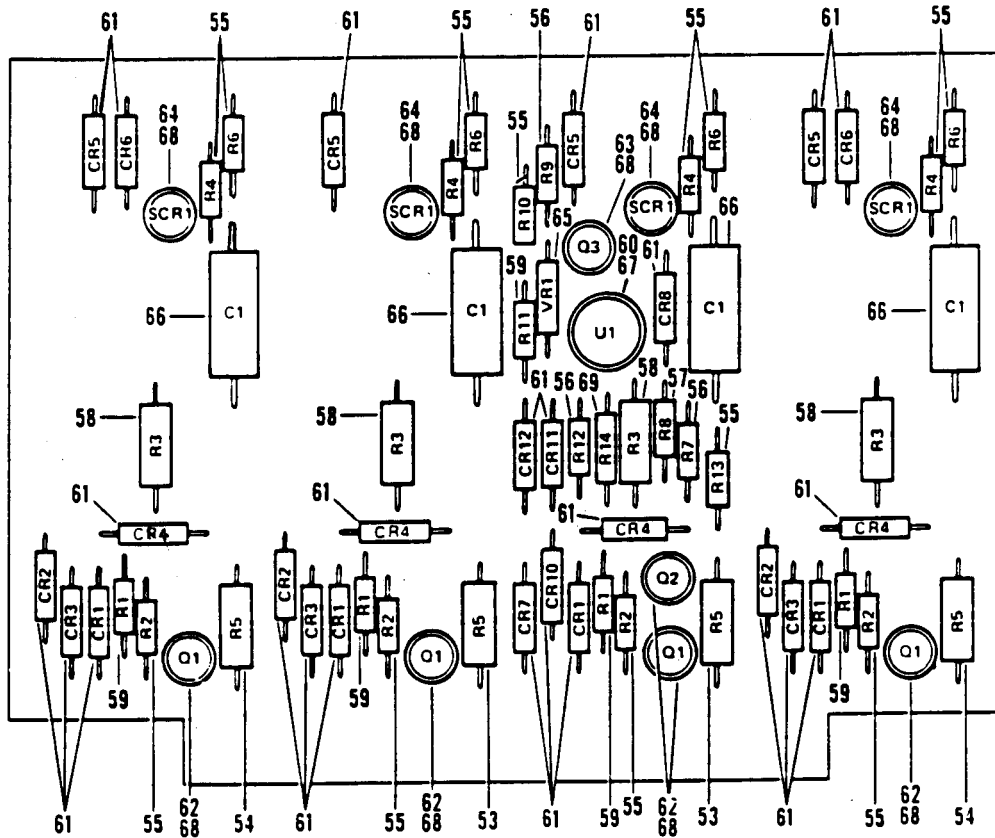

Figure 9-17.6 Indicating Light Circuit Card (Sheet 2 of 4)

81-1886-9



18-1886-11

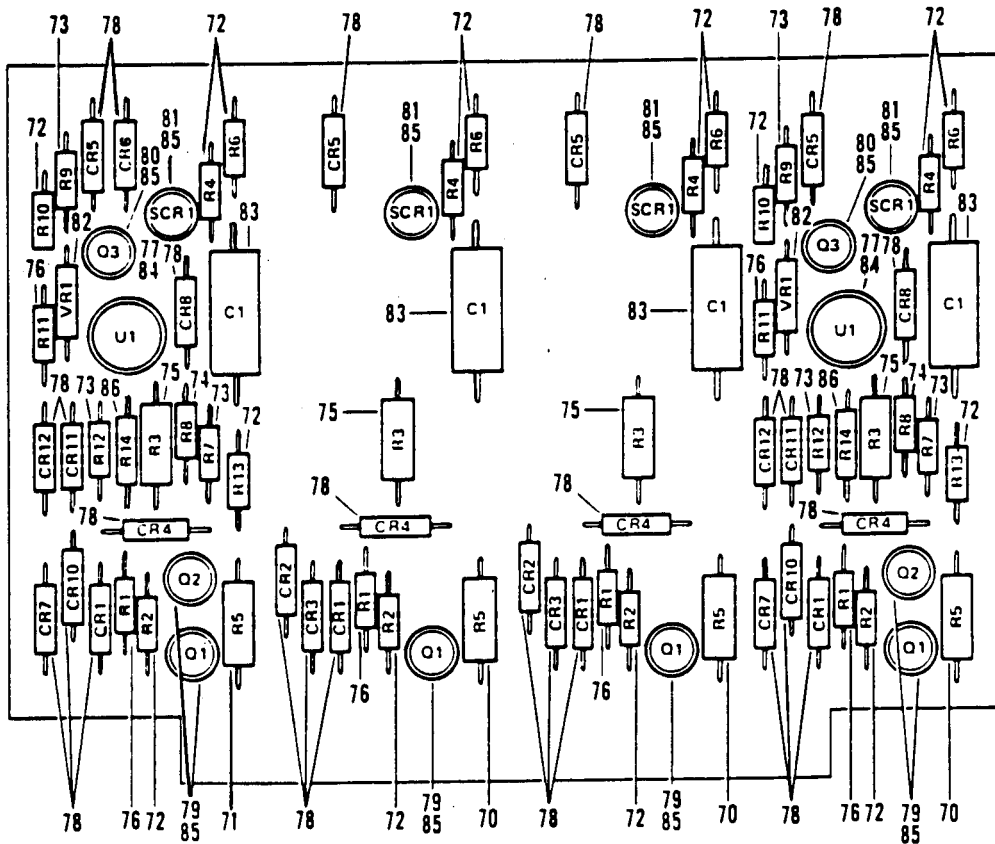
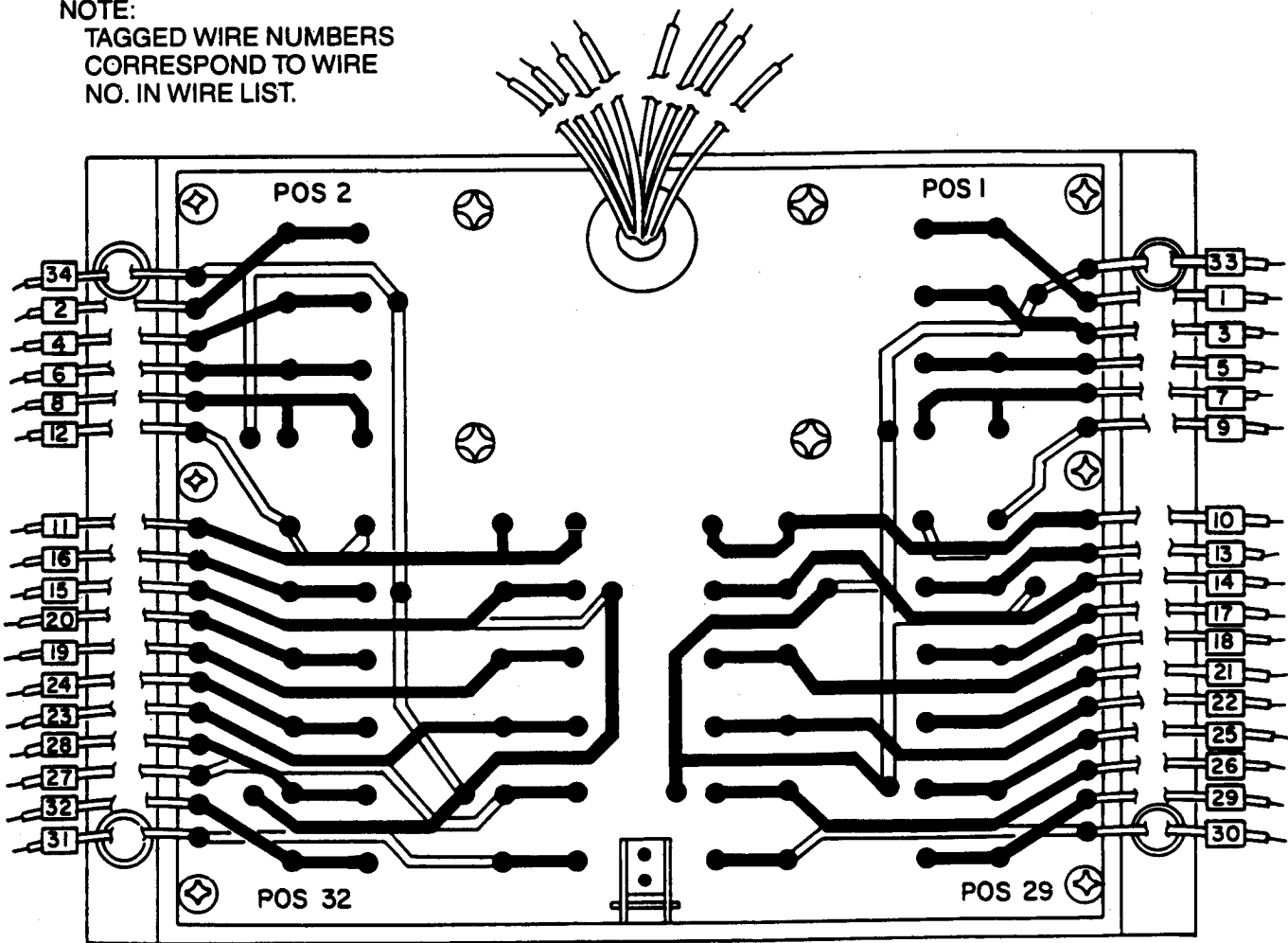

Figure 9-17.6 Indicating Light Circuit Card (Sheet 3 of 4)

- |                           |                           |                           |
|---------------------------|---------------------------|---------------------------|
| 1. Resistor               | 30. Resistor              | 59. Resistor              |
| 2. Resistor               | 31. Diode                 | 60. Operational amplifier |
| 3. Diode                  | 32. Resistor              | 61. Diode                 |
| 4. Resistor               | 33. Resistor              | 62. Transistor            |
| 5. Resistor               | 34. Operational amplifier | 63. Transistor            |
| 6. Capacitor              | 35. Mounting pad          | 64. Diode                 |
| 7. Diode                  | 36. Capacitor             | 65. Diode                 |
| 8. Mounting pad           | 37. Diode                 | 66. Capacitor             |
| 9. Transistor             | 38. Resistor              | 67. Mounting pad          |
| 10. Resistor              | 39. Transistor            | 68. Mounting pad          |
| 11. Resistor              | 40. Resistor              | 69. Resistor              |
| 12. Resistor              | 41. Resistor              | 70. Resistor              |
| 13. Resistor              | 42. Diode                 | 71. Resistor              |
| 14. Resistor              | 43. Resistor              | 72. Resistor              |
| 15. Resistor              | 44. Resistor              | 73. Resistor              |
| 16. Diode                 | 45. Transistor            | 74. Resistor              |
| 17. Transistor            | 46. Mounting pad          | 75. Resistor              |
| 18. Mounting Pad          | 47. Resistor              | 76. Resistor              |
| 19. Operational amplifier | 48. Diode                 | 77. Operational amplifier |
| 20. Capacitor             | 49. Resistor              | 78. Diode                 |
| 21. Mounting pad          | 50. Resistor              | 79. Transistor            |
| 22. Diode                 | 51. Capacitor             | 80. Transistor            |
| 23. Diode                 | 52. Diode                 | 81. Diode                 |
| 24. Resistor              | 53. Resistor              | 82. Diode                 |
| 25. Transistor            | 54. Resistor              | 83. Capacitor             |
| 26. Resistor              | 55. Resistor              | 84. Mounting pad          |
| 27. Resistor              | 56. Resistor              | 85. Mounting pad          |
| 28. Transistor            | 57. Resistor              | 86. Resistor              |
| 29. Mounting pad          | 58. Resistor              |                           |

Figure 9-17.6 Indicating Light Circuit Card (Sheet 4 of 4)

NOTE:  
TAGGED WIRE NUMBERS  
CORRESPOND TO WIRE  
NO. IN WIRE LIST.



08384A

Figure 9-17.7 Contact Assembly (A10)

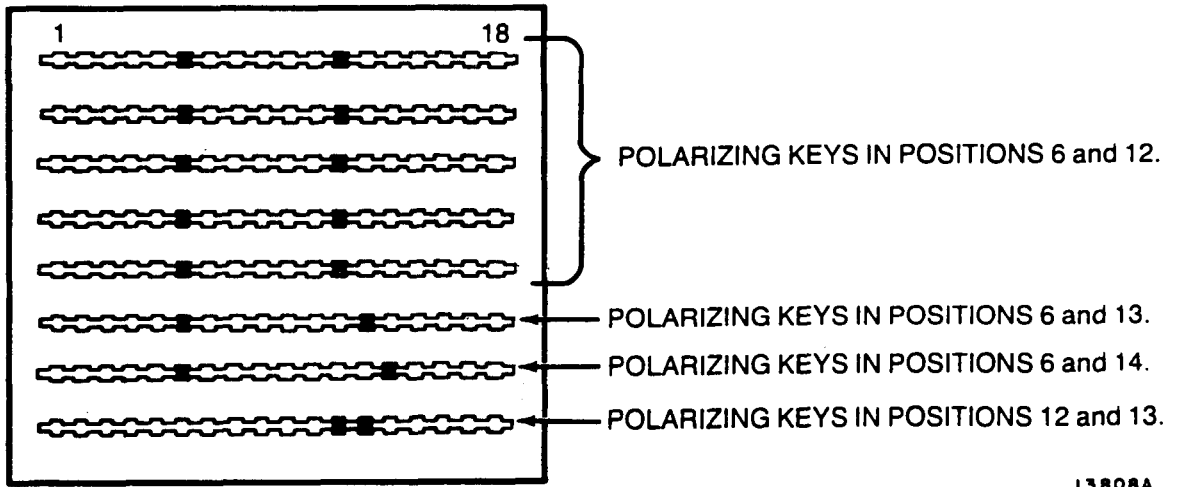

13808A

Figure 9-17.8 Polarizing Keys Location

**9-279.1. CLEANING - PILOTS CAUTION PANEL.**

**WARNING**

Solvent is highly flammable and toxic. Use only in wall ventilated areas away from flame and hot surfaces. Avoid skin contact. Breathing fumes, or directing compressed air at solvent in contact with skin could result in personal injury.

**CAUTION**

Do not use solvent for cleaning nonmetallic parts, electrical wiring, or electronic parts. Solvent could damage parts.

- a. Clean metal parts with dry cleaning solvent (C112).
- b. Clean electrical parts with a clean, soft, lint-free cloth moistened with isopropyl alcohol (C64). Allow to air dry.
- c. Gently wipe printed circuit boards with a clean, soft, lint-free cloth moistened with isopropyl alcohol (C64). Allow to air dry. Use care to prevent damage to printed circuits.

**9-280. INSPECTION - PILOTS CAUTION PANEL.**

- a. Check all parts for general condition and for structural damage that impairs proper system operation.
- b. Check internal and external threads for evidence of wear, stripping, and crossthreading.
- c. Visually inspect wiring for damaged insulation.
- d. Visually inspect all soldered connections for looseness and corrosion. Do not stress joint during inspection.
- e. Visually inspect printed circuit boards for burned, broken, or damaged circuits.

f. Check printed circuit boards for delamination of metal foil wiring pattern.

**9-280.1. REPAIR - PILOTS CAUTION PANEL.**

**NOTE**

Perform steps b thru d only as required for repair.

Repair procedures for caution panel consist of replacement of damaged or defective parts with serviceable ones. Removal and installation, by riveting or soldering, of any part or parts are covered in this paragraph.

- a. Replace parts that do not meet inspection requirements, Chase damaged threads.
- b. When replacing any part or subassembly secured by rivets, proceed as follows:
  - (1) Drill out rivets with proper size drill.
  - (2) Deburr and assemble new parts.
  - (3) Secure parts with new rivets of size and type indicated in Repair Parts and Special Tools List (RPSTL).
- c. When replacing components on printed circuit boards use the following precautions:
  - (1) Use a low wattage (25 watts or less) soldering iron.
  - (2) Ground circuit track adjacent to components.
  - (3) Use heat sinks to avoid overheating adjacent components.
  - (4) Coat printed circuit boards with insulating compound (C63.1).
- d. Finish all visible exterior surfaces, except hardware, with black anodic (C18.1). Refer to figure 9-17.8 for areas not to be finished.

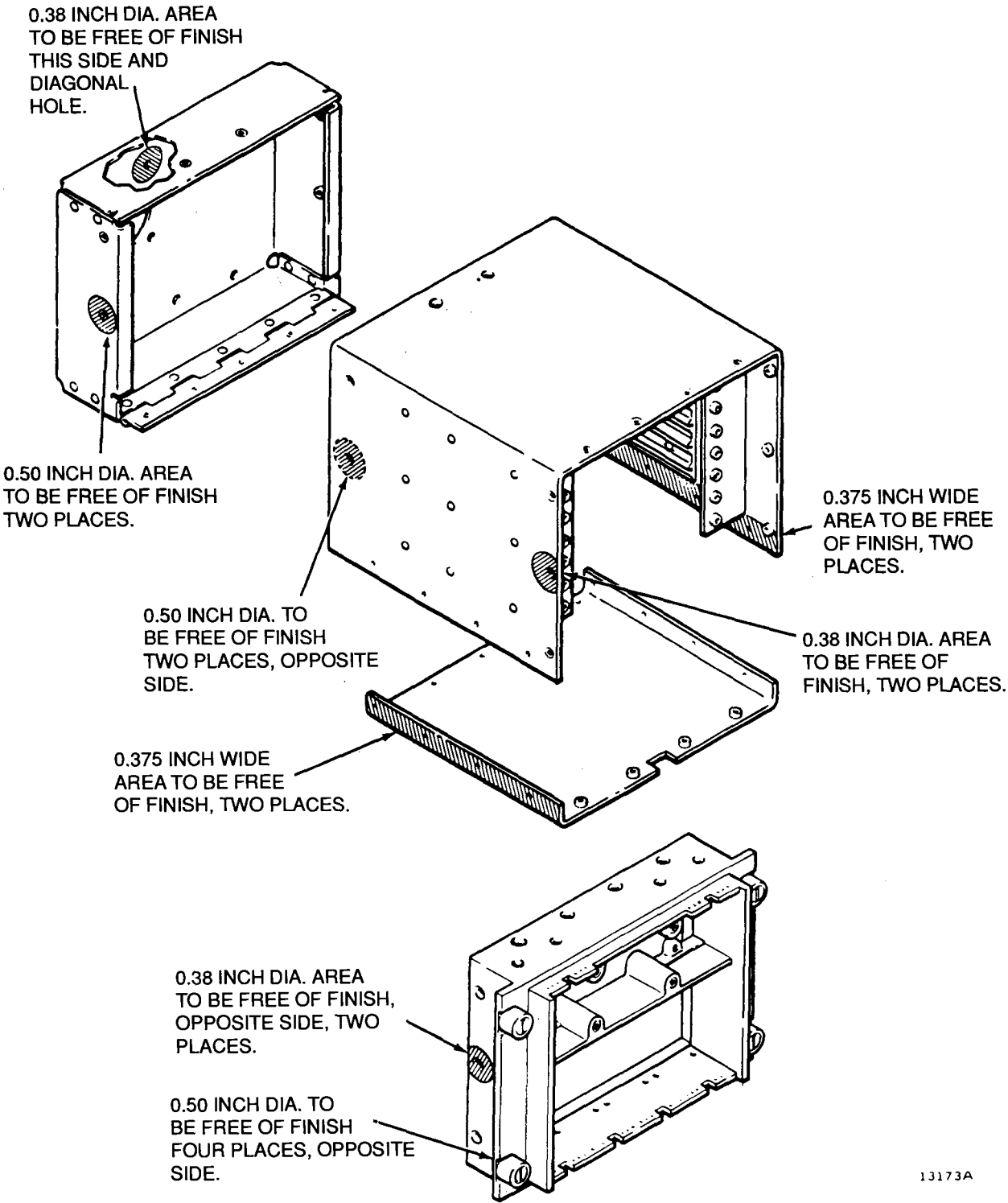

13173A

Figure 9-17.9 Removal of Finish for Electrical Bonding

**9-281. ASSEMBLY - PILOTS CAUTION PANEL.**

a. Install polarizing keys (58, figure 9-17.2) in receptacle connectors (56). Refer to figure 9-17.7 for locations.

b. Install receptacle connectors (56, figure 9-17.2) in housing assembly (59) as follows:

(1) Solder wires to pins on receptacle connectors (56).

(2) Install receptacle connectors (56) on brackets (71) and secure with screws (57).

c. Assemble contact assembly (38) as follows:

(1) Install turnlock stud assemblies (54) in housing (55).

(2) Install pins (53) in housing (55).

(3) Install printed circuit board (48) on housing (55) and secure with screws (49 and 50).

(4) Solder wires to printed circuit board (48). Refer to figure 9-17.6 and table 9-15.2 for wiring information.

(5) Install contacts (43 and 44, figure 9-17.2) in latch base assemblies (40 and 41). Refer to figure 9-17.9 for proper location.

(6) Install springs (42, figure 9-17.2) on top of contacts (43 and 44).

(7) Engage hole in levers (45) with tabs in latch base assemblies (40 and 41). Install latch base assemblies (40 and 41) in housing (55) using levers (45).

(8) Secure latch base assemblies (40 and 41) in housing (55) using screws (46 and 47).

(9) Lightly push in on contacts (43 and 44) to ensure springs (42) are properly installed.

d. install contact assembly (38) in housing assembly (59) and secure with screws (39).

**CAUTION**

**Use care when installing printed circuit boards (34 thru 37) to prevent damage to components.**

e. Refer to paragraph 9-279. Hold lower cover assembly (65) out of way and install printed circuit boards (34 thru 37) in correct receptacle connectors (56), component side downward.

f. Install receptacle connector (31) in cover assembly (65) as follows:

(1) Solder wires to pins on receptacle connector (31).

(2) Install receptacle connector (31) and secure with two screws (33) and self-locking nuts (32).

**CAUTION**

**Use care when installing printed circuit board (20) to prevent damage to components.**

g. Install printed circuit board (20) in receptacle connector (31) and secure with two screws (21) and lockwashers (22).

h. Solder wires to pins on radio filter (18). Install radio filter (18) and secure with screw (19).

i. Install pins and wires in connector (14). Install connector (14) and lug terminal (17). Secure with four screws (16) and self-locking nuts (15).



Table 9-15.2. Pilots Caution Panel Wiring Chart

WIRE NO.	FROM CONNECTOR/PIN	TO CONNECTOR/PIN	COLOR	WIRE	
				LENGTH	
1	A10-1	XA1-2	YEL	A/R	
2	A10-2	XA1-9	YEL	A/R	
3	A10-3	XA1-16	YEL	A/R	
4	A10-4	XA1-18	YEL	A/R	
5	A10-5	XA2-2	YEL	A/R	
6	A10-6	XA2-9	YEL	A/R	
7	A10-7	XA2-16	YEL	A/R	
8	A10-8	XA2-18	YEL	A/R	
9	A10-9	XA3-2	YEL	A/R	
10	A10-10	XA3-9	YEL	A/R	
11	A10-11	XA3-16	YEL	A/R	
12	A10-12	XA3-18	YEL	A/R	
13	A10-13	XA4-2	YEL	A/R	
14	A10-14	XA4-9	YEL	A/R	
15	A10-15	XA4-16	YEL	A/R	
16	A10-16	XA4-18	YEL	A/R	
17	A10-17	XA5-2	YEL	A/R	
18	A10-18	XA5-9	YEL	A/R	
19	A10-19	XA5-16	YEL	A/R	
20	A10-20	XA5-18	YEL	A/R	
21	A10-21	XA6-2	YEL	A/R	
22	A10-22	XA6-9	YEL	A/R	
23	A10-23	XA6-16	YEL	A/R	
24	A10-24	XA6-18	YEL	A/R	
25	A10-25	XA7-2	YEL	A/R	
26	A10-26	XA7-9	YEL	A/R	
27	A10-27	XA7-16	YEL	A/R	
28	A10-28	XA7-18	YEL	A/R	
29	A10-29	XA8-2	YEL	A/R	
30	A10-30	XA8-9	YEL	A/R	
31	A10-31	XA8-16	YEL	A/R	
32	A10-32	XA8-18	YEL	A/R	
33	A10-33	XA9-2	RED	A/R	
34	A10-34	XA9-2	RED	A/R	
35	A10-35	XA8-3	GRN	A/R	
36	A10-36	XA8-8	PNK	A/R	
37	A10-37	J1-k	BLU	A/R	
38	A10-38	XA9-15	BRN	A/R	
39	A10-39	XA9-16	GRY	A/R	
40	A10-40	XA9-8	ORN	A/R	
41	A10-41	J1-j	VIO	A/R	
42	A10-42	XA9-10	BLK	A/R	
43	J1-A	XA1-1	WHT	14	
44	J1-B	XA1-4	WHT	14	
45	J1-C	XA1-11	WHT	14	
46	J1-D	XA1-17	WHT	14	
47	J1-E	XA2-1	WHT	14	
48	J1-F	XA2-4	WHT	14	

Table 9-15.2. Pilots Caution Panel Wiring Chart (Cont)

WIRE NO.	FROM CONNECTOR/PIN	TO CONNECTOR/PIN	COLOR	WIRE LENGTH
49	J1-G	XA2-11	WHT	14
50	J1-H	XA2-17	WHT	12
51	J1-J	XA3-1	WHT	12
52	J1-K	XA3-4	WHT	12
53	J1-L	XA3-11	WHT	12
54	J1-M	XA3-17	WHT	12
55	J1-N	XA4-1	WHT	11
56	J1-P	XA4-4	WHT	12
57	J1-R	XA4-11	WHT	12
58	J1-S	XA4-17	WHT	11
59	J1-T	XA5-1	WHT	12
60	J1-U	XA5-4	WHT	12
61	J1-V	XA5-11	WHT	12
62	J1-W	XA5-17	WHT	11
63	J1-X	XA6-1	WHT	11
64	J1-Y	XA6-4	WHT	12
65	J1-Z	XA6-11	WHT	11
66	J1-a	XA6-17	WHT	10
67	J1-b	XA7-1	WHT	11
68	J1-c	XA7-4	WHT	11
69	J1-d	XA7-11	WHT	10
70	J1-e	XA7-17	WHT	10
71	J1-f	XA8-1	WHT	10
72	J1-g	XA8-4	WHT	10
73	J1-h	XA8-11	WHT	10
74	J1-i	XA8-17	WHT	10
75	J1-m	XA9-10	BLK	10
76	J1-n	XA11-1	ORN	9
77	J1-p	XA9-12	PNK	12
78	J1-q	XA9-9	GRY	10
79	J1-r	XA9-2	RED	9
80	J1-s	XA9-4	GRY	10
81	J1-t	XA9-5	GRY	10
82	XA11-2	XA9-8	ORN	10
83	XA11-3	XA9-11	BLK	10
84	XA9-8	XA8-10	ORN	10
85	XA9-11	XA8-7	BLK	10
86	J1-1	XA9-11	BLK	10
87	XA9-18	XA9-8	BUSWIRE	A/R
88	XA9-1	XA8-8	GRN	9
89	XA9-6	XA8-15	GRN	10
90	XA9-17	XA8-5	GRN	11

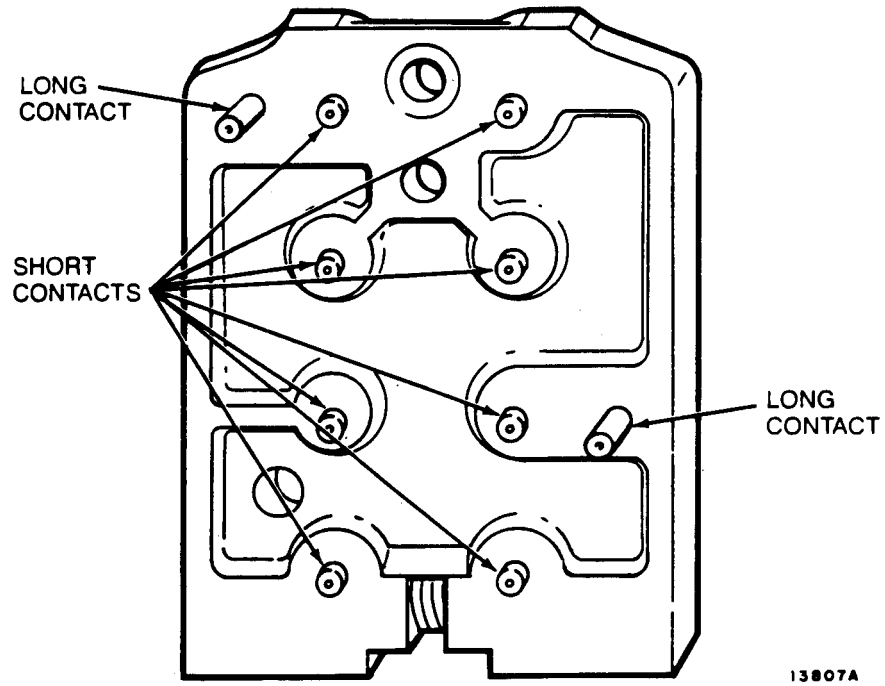

Figure 9-17.10 Position of Contacts in Latch Base

j. Carefully close cover assembly (65), ensuring wiring is clear. Secure with six screws (13) in two sides and top of housing assembly (59).

k. Assemble toggle switch assembly (1) as follows:

(1) Insert connector (8) through switch plate (12). Install lug terminal (11) and lockwasher (10) on connector (8). Secure with ferrule nut (9).

(2) Install one lockwasher (7) on each toggle switch (5).

(3) Insert toggle switches (5) through switch plate (12) and secure with knurled nuts (6).

l. Attach wire to connector (8) using screw (3) and lockwasher (4).

m. Install toggle switch assembly (1) on contact assembly (38) and secure with two screws (2).

n. If identification plate (15, figure 9-17.1) was removed from panel subassembly (16), install a new one.

o. Refer to figures 9-13 thru 9-15 and assemble cap assemblies (1 and 7, figure 9-17.1) as follows:



**Ensure correct legends are installed in correct indicator light positions. If legends are installed in wrong positions, aircrew will receive false information during inflight malfunctions.**

(1) Install white filters (6 or 12), legends (5 or 11), and gray filters (4 or 10) in bases. Install gray filters (4 or 10) with dull side facing out.

(2) Secure with lens retainers (3 or 9).

(3) Place cap assemblies (1 and 7) face down and install two lamps (2 or 8) in each indicator lamp position.

**NOTE**

**The cap assemblies are color coded and keyed for correct positioning in contact assembly.**

p. Insert cap assemblies (1 and 7) in correct position and firmly push until it snaps into place.



**Do not overtighten screws (14) or light indicating panel (13) may crack.**

q. Install light indicating panel (13) by pushing in until connector mates, secure using two screws (14).

**9-281.1. INSTALLATION - PILOTS CAUTION PANEL.**

a. Connect electrical connector to back of caution panel.

b. Position panel in helicopter instrument pane and tighten fasteners.

**9-282. GUNNERS CAUTION PANEL (BHT P/N 204-075-705-77, and -83).**

**9-282.1. DESCRIPTION - GUNNERS CAUTION PANEL.**

There are three lamp driver circuit boards in the gunners caution panel. Each circuit board drives six circuits for a total of 18 light positions. The three boards (P/N 76-1127-1 & -3) are identical, except that one of the boards (P/N 76-1127-3) contains a larger resistor in one circuit. The BRT/DIM circuitry is contained on circuit card assembly (P/N 76-1129-1). The BRT/DIM switch is located on the face of the unit along with a TEST switch. An edge lit panel (P/N 76-1131-1) provides illumination for the unit. Refer to paragraph 9-275 for system description and 9-276 for system functional testing.

a. Refer to schematic figure 9-17.10. The three lamp driver boards (P/N 76-1127) receive their fault signals (one +28 Vdc apply fault and six ground apply faults on each board) through connector J1 at the back of the unit. The signal (for each typical circuit) is routed through wiring to the circuit board edge connector. A typical ground apply fault will pass through diode CR3 and out the circuit card edge connector to the indicator lamps. The lamps will light since +28 Vdc is constantly available as CAUTION SEGMENT POWER through J1-z and circuit card edge connector pin 1. This is routed across resistor R1 and through pins (2, 4, 6, 7, 8, 9 and R) of the

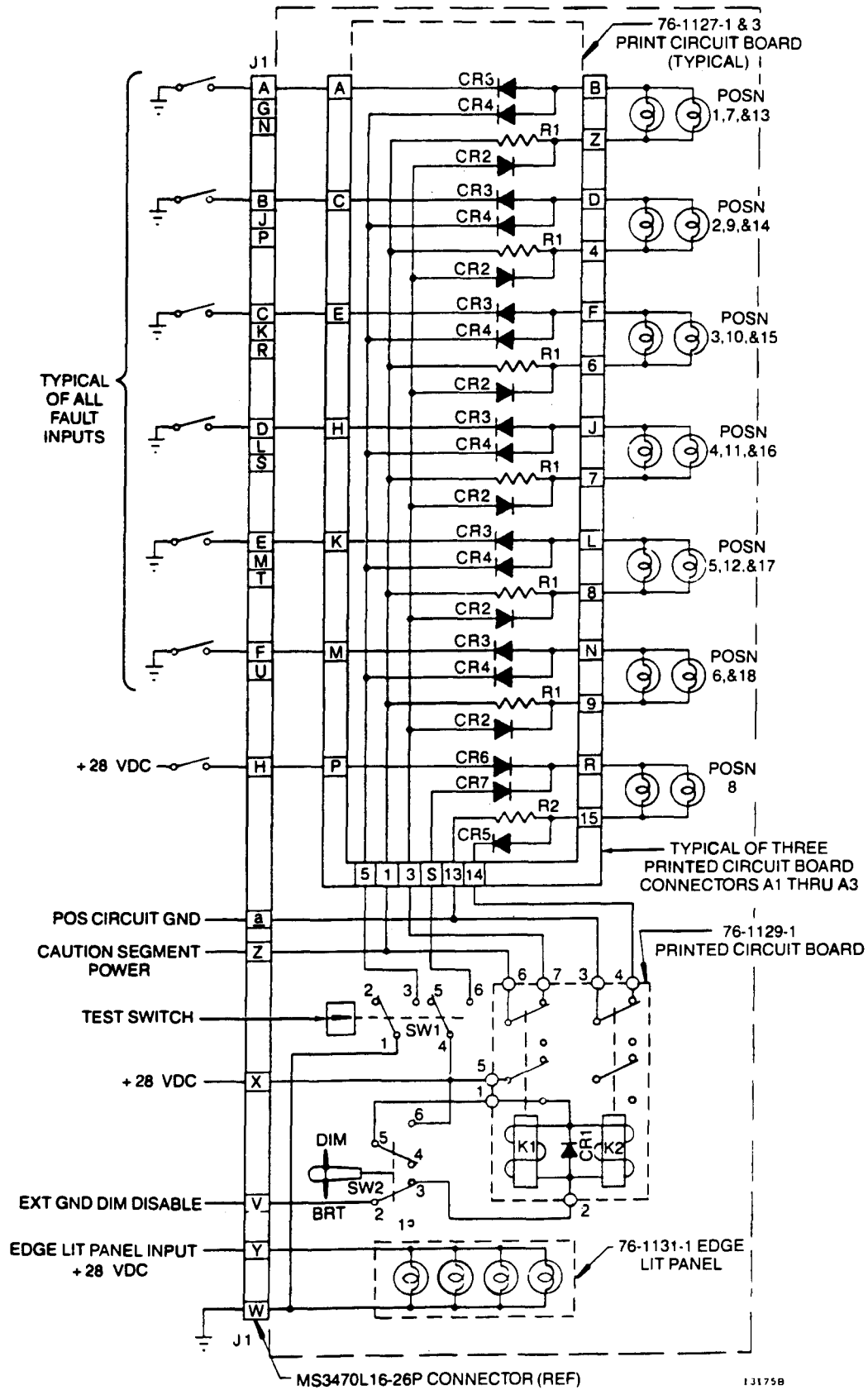

Figure 9-17.11 Gunners Caution Panel Schematic Diagram

edge connector to the indicator lamps. When the BRT/DIM switch (SW2) is placed in the BRT position, +28 Vdc is applied through pin 3 of the edge connector, across diode CR2 and out the previously mentioned pins to the lamps. The lamps will light brightly since resistor R1 is bypassed in each circuit. When the TEST pushbutton (SW1) is pushed, ground from J1-W is applied through edge connector 5 and diode CR4 to each lamp circuit. All the lamps will light. In the case of the +28 Vdc apply circuit, the fault signal is applied through J1-H and edge connector pin P across diode CR6 and out edge connector pin R to the indicator lamps. Ground for this circuit comes through J1-a and edge connector pin 13 across resistor R2 in the dim mode. In the bright mode, ground is provided through edge connector pin 14, across diode CR5 (bypassing resistor R2) and out edge connector pin 15 to light the lamps of position 8. During test, +28 Vdc arrives through edge connector pin 5 and passes through diode CR7 to light the lamps as described earlier.

b. Circuit card assembly (P/N 76-1129-1) contains two relays (K1 & K2) and diode CR1. The board constantly receives +28 Vdc through terminals 5 and 6, and ground through terminal 3. When the BRT/DIM switch (SW2) is placed to the BRT position, ground is absent from terminal 2. This de-energizes relays K1 & K2. In this state, BRT mode +28 Vdc at terminal 6 is applied, through terminal 7, to edge connector pin 3 on circuit cards (P/N 76-1127). At the same time, ground at terminal 3 is felt out through terminal 4 to edge connector pin 14. This provides ground for the positive apply lamps. When the BRT/DIM switch is placed in the DIM position, ground for relays (K1 & K2) is applied to terminal 2 from J1-V. The +28 Vdc through J1-X and contacts of SW2, energizes the relays through terminal 1, and latches the relays through terminal 5. The +28 Vdc at terminal 7 (BRT mode for negative apply fault circuits) is removed. Also, the ground at terminal 3 is removed from terminal 4 (BRT mode ground for positive apply circuit).

c. The TEST switch (SW1) receives ground through J1-W and applies it, through its switching contacts, to pin 5 of the edge connectors. This ground lights all the negative apply circuits during TEST.

d. The four lamps of the edge lit panel (P/N 76-1131) receive +28 Vdc through J1-Y, and ground through J1-W.

### 9-283. REMOVAL - GUNNERS CAUTION PANEL.

a. Loosen fasteners and lift caution panel from instrument panel.

b. Disconnect electrical connector from the rear of unit.

### 9-283.1. BENCH TESTING - GUNNERS CAUTION PANEL.

a. Refer to schematic figure 9-17.10. Apply +28 Vdc to J1-X, Y and Z. Apply ground to pins J1-W and J1-a. The edge lit panel lamps shall light.

b. Press the TEST pushbutton and hold it. Place the BRT/DIM switch to the BRT position. All the indicator positions shall light brightly.

c. Check BRT/DIM operation:

(1) Apply ground to pin J1-V. Press and hold the TEST pushbutton. All 18 positions shall remain brightly illuminated.

(2) Momentarily place the BRT/DIM switch to DIM. All 18 positions shall reduce in illumination and remain dim after the BRT/DIM switch is released.

(3) Place the BRT/DIM switch to BRT while still holding the TEST pushbutton. All 18 positions brightly illuminate.

(4) While still pressing the TEST pushbutton, remove ground from pin J1-V. All 18 positions shall remain brightly illuminated.

d. Refer to table 9-15.3. One at a time, momentarily apply ground to each pin of connector J1 that receives a negative input. Only the position being tested should light brightly.

e. Repeat step c. above applying +28 Vdc only to pin J1-H. Position 8 should light brightly.

Table 9-15.3. Gunners Caution Panel Fault Inputs

75-0326-1 <b>P</b>				
	NOMENCLATURE	PIN NO.	FILTER COLOR INPUT	FAULT
1	ENGINE OIL PRESS	A	AVN YELLOW	NEG
2	SPARE	B	AVN YELLOW	NEG
3	ENG FUEL PUMP	c	AVN YELLOW	NEG
4	SPARE	D	AVN YELLOW	NEG
5	SPARE	E	AVN YELLOW	NEG
6	HYDR PRESS #1	F	AVN YELLOW	NEG
7	DC GEN	G	AVN YELLOW	NEG
8	GOV EMER	H	AVN YELLOW	POS
9	FUEL LOW	J	AVN YELLOW	NEG
10	SPARE	K	AVN YELLOW	NEG
11	CHIP DECTOR	L	AVN YELLOW	NEG
12	EMER HYDR PUMP ON	M	AVN GREEN	NEG
13	XMSN OIL PRESS	N	AVN YELLOW	NEG
14	XMSN OIL TEMP	P	AVN YELLOW	NEG
15	FUEL FILTER	R	AVN YELLOW	NEG
16	SPARE	s	AVN YELLOW	NEG
17	SPARE	T	AVN YELLOW	NEG
18	HYDR PRESS #2	u	AVN YELLOW	NEG

75-0326-3 <b>E M</b>				
	NOMENCLATURE	PIN NO.	FILTER COLOR INPUT	FAULT
1	ENGINE OIL PRESS	A	AVN YELLOW	NEG
2	SPARE	B	AVN YELLOW	NEG
3	ENG FUEL PUMP	C	AVN YELLOW	NEG
4	ALTER	D	AVN YELLOW	NEG
5	SPARE	E	AVN YELLOW	NEG
6	#1 HYD PRESS	F	AVN YELLOW	NEG
7	SPARE	G	AVN YELLOW	NEG
8	GOV EMERG	H	AVN YELLOW	POS
9	FUEL LOW	J	AVN YELLOW	NEG
10	RECT	K	AVN YELLOW	NEG
11	CHIP DETECTOR	L	AVN YELLOW	NEG
12	EMERG HYD PUMP ON	M	AVN GREEN	NEG
13	TRANS OIL PRESS	N	AVN YELLOW	NEG
14	TRANS OIL HOT	P	AVN YELLOW	NEG
15	FUEL FILTER	R	AVN YELLOW	NEG
16	DC GEN	S	AVN YELLOW	NEG
17	SPARE	T	AVN YELLOW	NEG
18	#2 HYD PRESS	U	AVN YELLOW	NEG

9-284. TROUBLESHOOTING - GUNNERS CAUTION PANEL.

NOTE

Before you use this table, be sure you have performed all operational checks.

Table 9-15.4. Troubleshooting - Gunners Caution Panel

---

CONDITION

TEST OR INSPECTION

**CORRECTIVE ACTION**

1. Edge lit panel fails to illuminate.

STEP 1. Substitute known good lamps.

**If lamps are defective, install serviceable lamps. (Refer to paragraph 9-284.1.)**

STEP 2. Check for corrosion in lamp socket.

**If required, clean lamp socket terminals or replace lamp. (Refer to paragraph 9-18.)**

2. All 18 positions fail to illuminate during lamp TEST.

STEP 1. Test operation of circuits with multimeter.

**If TEST switch or wiring is damaged or defective, replace as required. (Refer to paragraph 9-16.)**

3. During lamp TEST, one position is dim only.

STEP 1. Substitute two known good lamps.

**If one of two lamps is defective, replace with serviceable lamp.**

STEP 2. Check for corrosion in lamp socket.

**If required, clean lamp socket terminals or replace lamp. (Refer to paragraph 9-18.)**

STEP 3. Replace diode CR2 for negative apply circuits, or CR5 for positive apply circuit (position 8).

**If diode is defective, remove and install a serviceable one. (Refer to paragraph 9-286.)**

STEP 4. Substitute a known good printed circuit board into string of circuits. (Refer to figures 9-16 and 9-17.)

**If problem is solved, replace defective printed circuit board with a serviceable one. (Refer to paragraph 9-284.1 and 9-286.1.)**



Table 9-15.4. Troubleshooting - Gunners Caution Panel (Cont)

## CONDITION

## TEST OR INSPECTION

## CORRECTIVE ACTION

4. During lamp TEST, one position does not illuminate.

STEP 1. Using multimeter, ensure lamp is properly grounded.

**If lamp is not properly grounded, remove lamp and clean ground. (Refer to paragraph 9-18.)**

STEP 2. Check for corrosion in lamp socket.

**If required, clean lamp socket terminals or replace lamp. (Refer to paragraph 9-18.)**

5. With BRT/DIM switch to BRT, and TEST button pushed, all 18 positions do not remain brightly illuminated when ground is applied to pin J1-V.

STEP 1. Use multimeter to check operation of switch SW1.

**If switch does not operate correctly, remove and install a serviceable one. (Refer to paragraph 9-12.)**

6. With the BRT/DIM switch in DIM position, all 18 positions do not light dimly.

STEP 1. Use multimeter to check resistor R1 (R2 in positive apply circuit) in affected circuit.

**If resistor is defective, remove and replace with a serviceable one. (Refer to schematic figure 9-17.10.)**

STEP 2. Use multimeter to check operation of switch SW2.

**If switch is defective, remove and install a serviceable one. (Refer to paragraphs 9-284.1 and 9-286.1.)**

STEP 3. Use multimeter to check operation of relays K1 and K2 and diode CR1.

**If a relay or diode is defective, remove and install a serviceable one. (Refer to paragraph 9-284.1.)**

7. All 18 positions do not remain brightly illuminated with BRT/DIM switch in BRT, and TEST pushbutton pressed.

STEP 1. Using a multimeter, check operation of switches SW1 and SW2.

**If either switch is defective, remove and install a serviceable one. (Refer to paragraphs 9-284.1 and 9-286.1.)**

Table 9-15.4. Troubleshooting - Gunners Caution Panel (Cont)

## CONDITION

## TEST OR INSPECTION

## CORRECTIVE ACTION

8. An individual position does not light when the proper fault is input at connector J1. Refer to table 9-15.3 for the proper fault input.

STEP 1. Substitute known good lamps.

**If lamps are found to be defective, install serviceable lamps. (Refer to paragraph 9-284.1.)**

STEP 2. Using a multimeter, check operation of diode CR3.

**If diode is defective, remove and install a serviceable one. (Refer to paragraph 9-286.)**

STEP 3. Check for corrosion in lamp socket.

**If required, clean lamp socket terminals or replace lamp. (Refer to paragraph 9-18.)**

STEP 4. Check for defective wiring with multimeter.

**If wiring is defective, repair or replace. (Refer to paragraph 9-11.)**

9. Position 8 does not light brightly when +28 Vdc is applied to pin J1-H.

STEP 1. Using multimeter, check operation of resistor R2 and diode CR5.

**If components are defective, remove and install serviceable ones. (Refer to paragraph 9-286.)**

STEP 2. Check for corrosion in lamp socket.

**If required, clean lamp socket terminals or replace lamp. (Refer to paragraph 9-18.)**

STEP 3. Check for defective wiring with multimeter.

**If wiring is defective, repair or replace. (Refer to paragraph 9-11.)**

10. Printed circuit board (17, figure 9-17.11) fails to operate.

STEP 1. Check printed circuit board for cracks, distortion, or burnt circuit tracks.

**If any damage is found, replace printed circuit board.**

STEP 2. Check components for cracks, broken leads, signs of overheating, or other physical damage.

**If any components are damaged, replace them. (Refer to paragraph 9-286.)**

STEP 3. Check for loose, broken, or "cold" solder joints using a multimeter.

**If any defective solder joints are found, repair them. (Refer to paragraph 9-286.)**

Table 9-15.4. Troubleshooting - Gunners Caution Panel (Cont)

---

**CONDITION****TEST OR INSPECTION****CORRECTIVE ACTION**

STEP 4. Use a multimeter to check components for electrical shorts or open circuits.

**If defective components are found, replace them. (Refer to paragraph 9-286.)**

11. Printed circuit board (18, figure 9-17.11) fails to operate.

STEP 1. Check printed circuit board for cracks, distortion, or burnt circuit tracks.

**If any damage is found, replace printed circuit board.**

STEP 2. Check components for cracks, broken leads, signs of overheating, or other physical damage.

**If any components are damaged, replace them (Refer to paragraph 9-286.)**

STEP 3. Check for loose, broken, or "cold" solder joints using a multimeter.

**If any defective solder joints are found, repair them. (Refer to paragraph 9-286.)**

STEP 4. Use a multimeter to check components for electrical shorts or open circuits.

**If defective components are found, replace them. (Refer to paragraph 9-286.)**

---

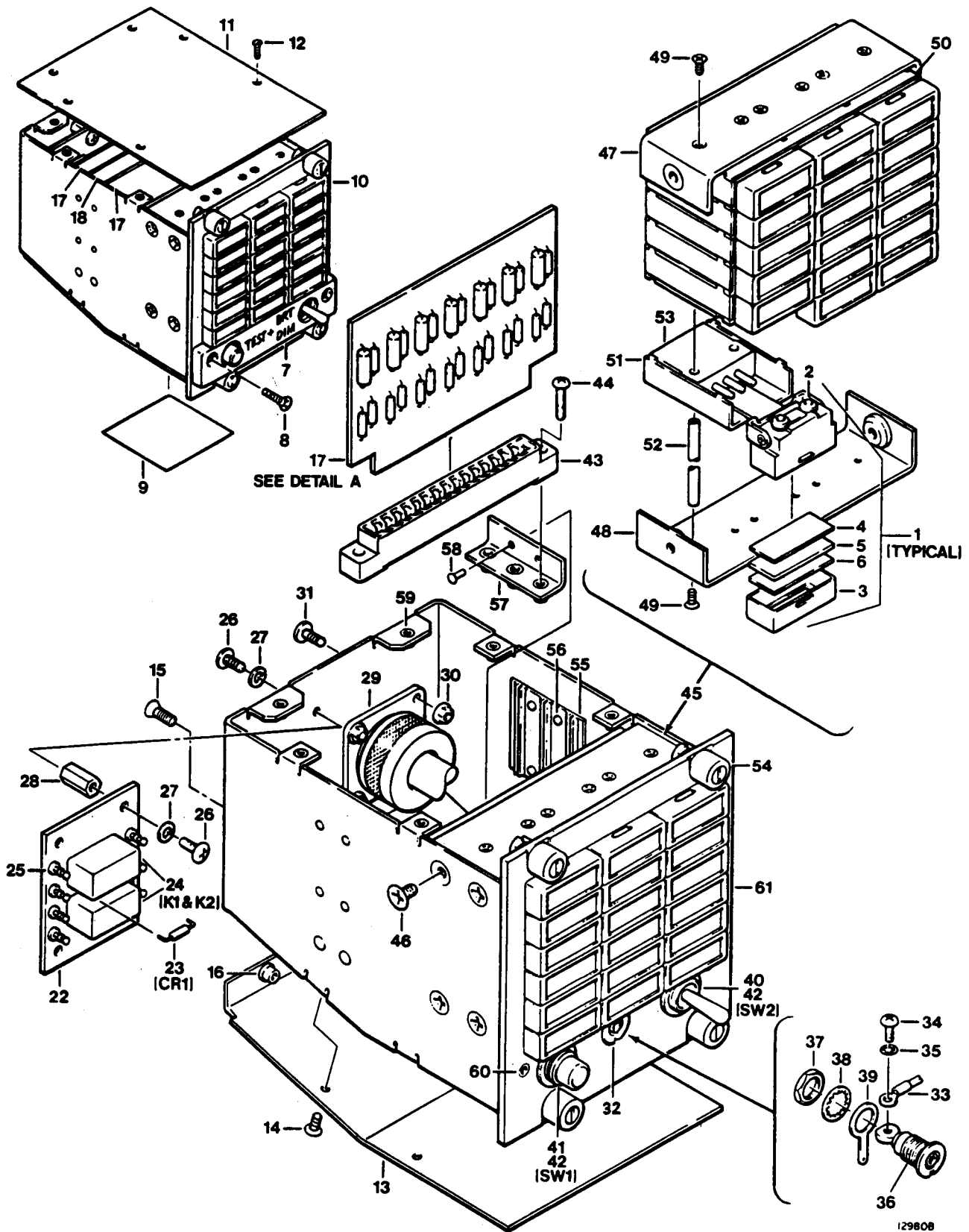
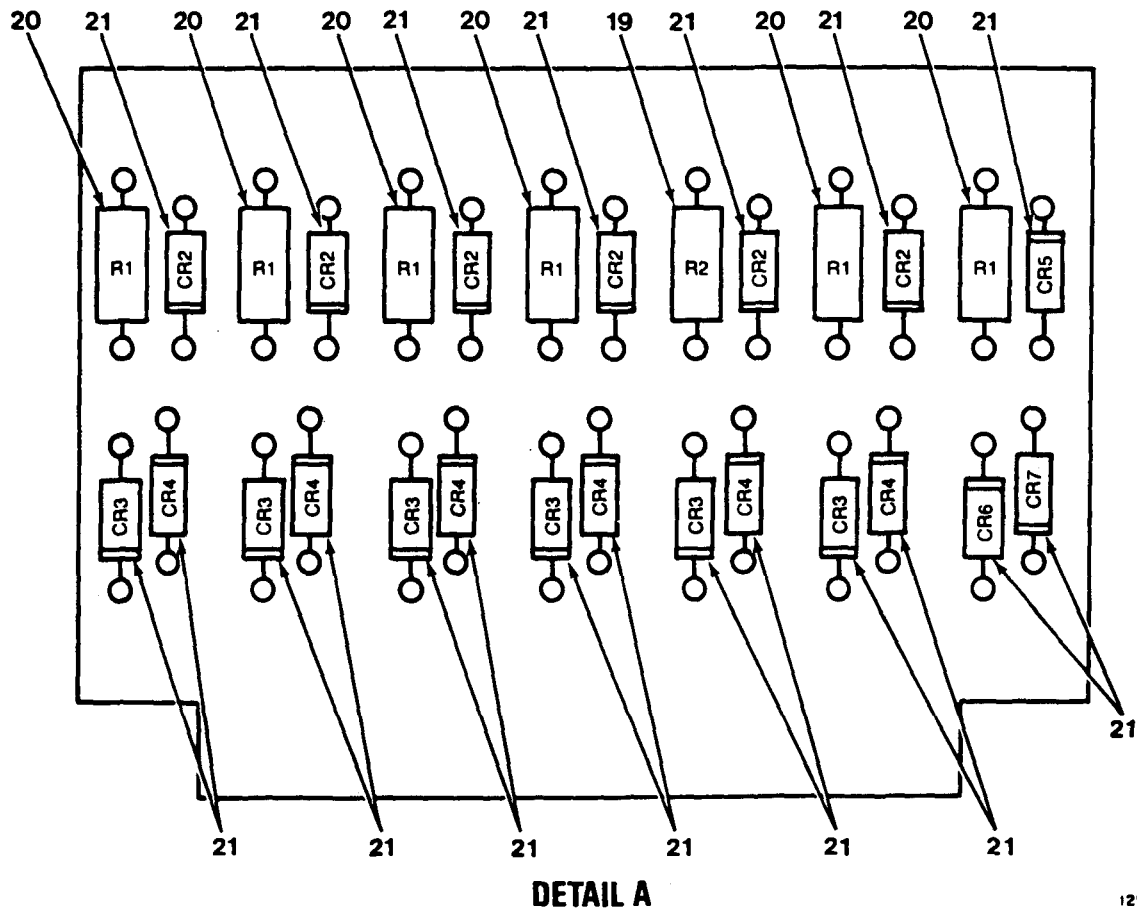

Figure 9-17.12 Gunners Caution Panel (Sheet 1 of 2)



- |                           |                                     |                                |                            |
|---------------------------|-------------------------------------|--------------------------------|----------------------------|
| 1. Indicator module       | 17. Printed circuit board (A1 & A3) | 32. Connector assembly         | 48.                        |
| 2. Lamp                   | 18. Printed circuit board (A2)      | 33. Lug terminal               | 49. Screw                  |
| 3. Lens retainer          | 19. Resistor                        | 34. Screw                      | 50. Spacer                 |
| 4. Gray filter (light)    | 20. Resistor                        | 35. Lockwasher                 | 51. Housing assembly       |
| 5. Legend                 | 21. Diode                           | 36. Connector                  | 52. Electrical post        |
| 6. Gray filter (dark)     | 22. Printed circuit board           | 37. Ferrule nut                | 53. Contact assembly       |
| 7. Light indicating panel | 23. Diode                           | 38. Lockwasher                 | 54. Turnlock stud assembly |
| 8. Screw                  | 24. Relay                           | 39. Lug terminal               | 55. Board guide            |
| 9. Identification plate   | 25. Terminal stud                   | 40. Toggle switch              | 56. Rivet                  |
| 10. Panel subassembly     | 26. Screw                           | 41. Pushbutton switch          | 57. Connector bracket      |
| 11. Cover plate           | 27. Lock-spring washer              | 42. Knurled plain nut          | 58. Rivet                  |
| 12. Screw                 | 28. Sleeve spacer                   | 43. Receptacle connector       | 59. Self-locking nut       |
| 13. Access cover plate    | 29. Connector                       | 44. Screw                      | 60. Self-locking nut       |
| 14. Screw                 | 30. Self-locking nut                | 45. Annunciator light assembly | 61. Annunciator housing    |
| 15. Screw                 | 31. Screw                           | 46. Screw                      |                            |
| 16. Self-locking nut      |                                     | 47. Bracket                    |                            |

Figure 9-17.12 Gunnery Caution Panel (Sheet 2 of 2)

**9-284.1. DISASSEMBLY - GUNNERS CAUTION PANEL.**

**NOTE**

**Perform steps a. (1) thru a. (3) only when these parts must be replaced. These steps are not required for other disassembly steps, for example, removing a printed circuit board.**

**a. Change lamps (2, figure 9-17.11) as follows:**

(1) Press indicator module (1) to unlatch, then pull forward and rotate face downward.

(2) Pry lamps (2) out with a thin, flat-bladed instrument. Replace lamps (2) with serviceable parts.

(3) Rotate indicator module (1) to horizontal position and push into housing assembly (51) until detent is reached.

**b. Remove lens retainers (3). Push gray filters (4 and 6) and legends (5) out of lens retainers (3).**

**c. Remove screws (8). Remove light indicating panel (7) from panel subassembly (10) by gently prying out to disconnect from connector assembly (32).**

**d. Remove six screws (12) and cover plate (11) from annunciator housing (61).**

**e. Remove identification plate (9) from access cover plate (13) only if damaged or illegible.**

**f. Remove four screws (14), two screws (15), and access cover plate (13) from annunciator housing (61).**



**Use care when unplugging printed circuit boards (17 and 18) to prevent damage to components.**

**NOTE**

**Refer to figure 9-17.12 and table 9-15.5 for wiring information.**

**g. Using circuit board puller (T93), unplug and tag printed circuit boards (17 and 18).**

**h. Remove four screws (26), lock-spring washers (27), and sleeve spacers (28) and printed circuit board (22).**

**i. Identify, tag, and unsolder wires from printed circuit board (22).**

**j. Remove four self-locking nuts (30) and screws (31), and connector (29).**

**k. Identify and tag wires. Remove pins from connector (29).**

**l. Remove connector assembly (32) from annunciator housing (61) as follows:**

(1) Remove screw (34), lockwasher (35), and lug terminal (33) from connector (36).

(2) Remove ferrule nut (37), lockwasher (38), and lug terminal (39) from connector (36).

(3) Remove connector (36) from annunciator housing (61).

**m. Remove two knurled plain nuts (42), toggle switch (40), and pushbutton switch (41) from annunciator housing (61). Identify, tag, and unsolder wires from switches (40 and 41).**

**n. Remove screws (44) and receptacle connectors (43) from annunciator housing (61). Identify, tag, and unsolder wires from receptacle connectors (43).**

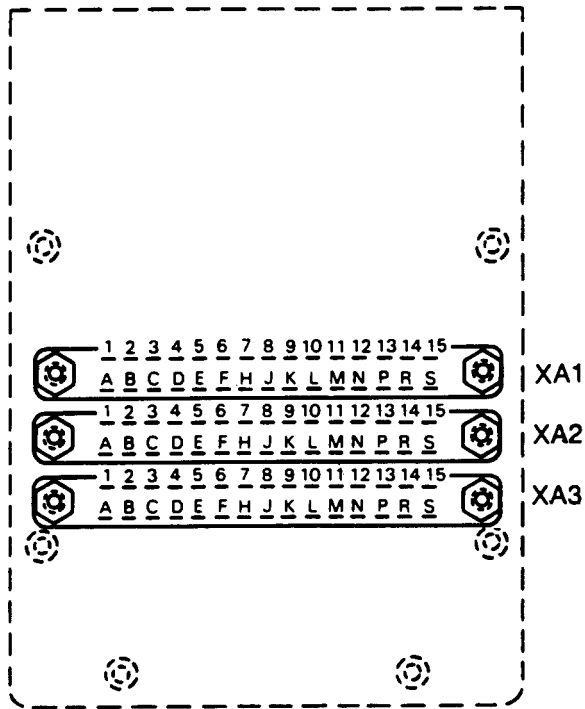

TOP VIEW OF RECEPTACLE CONNECTORS

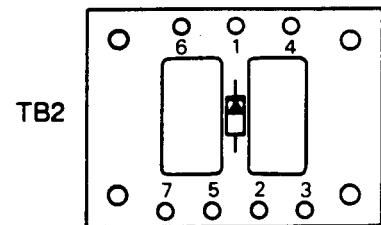
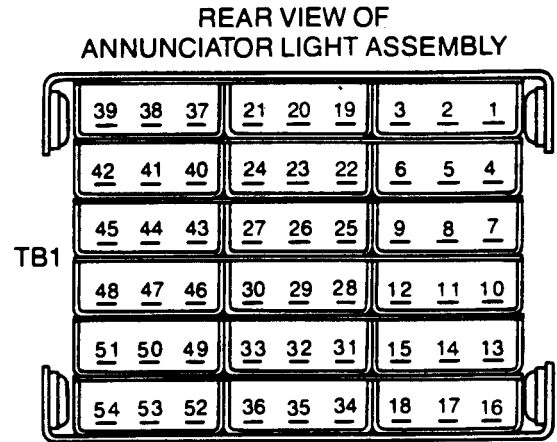

CIRCUIT CARD ASSEMBLY 76-1129-1

CONNECTOR ASSEMBLY

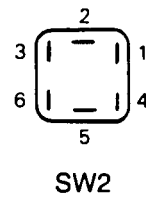
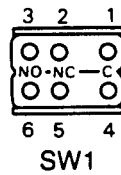
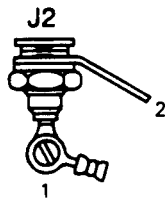

13172A

Figure 9-17.13 Gunners Caution Panel Wiring Connections

Table 9-15.5. Gunners Caution Panel Wiring Chart

**NOTE****Wire is 22 GA. unless otherwise indicated.****LENGTH IS SHOWN IN INCHES.**

WIRE NO.	FROM CONNECTOR/PIN	TO CONNECTOR/PIN	COLOR	WIRE LENGTH
1	J1-A	XA1-A	YEL	6
2	J1-B	XA1-C	YEL	6
3	J1-C	XA1-E	YEL	7
4	J1-D	XA1-H	YEL	6
5	J1-E	XA1-K	YEL	7
6	J1-F	XA1-M	YEL	8
7	J1-G	XA2-A	YEL	5
8	J1-H	XA2-P	YEL	6
9	J1-J	XA2-C	YEL	6
10	J1-K	XA2-E	YEL	6
11	J1-L	XA2-H	YEL	7
12	J1-M	XA2-K	YEL	6
13	J1-N	XA3-A	YEL	5
14	J1-P	XA3-C	YEL	5
15	J1-R	XA3-E	YEL	5
16	J1-S	XA3-H	YEL	6
17	J1-T	XA3-K	YEL	6
18	J1-U	XA3-M	YEL	7
19	J1-V	SW2-2	BLK	8
20	J1-W	J2-2	BLK	9
21	J1-X	SW1-4	RED	9
22	J1-Y	J2-1	RED	9
23	J1-Z	TB2-6	RED	6
24	J1-c	TB2-3	BLK	7
25	XA1-B	TB1-1	WHT	5
26	XA1-D	TB1-4	WHT	5
27	XA1-F	TB1-7	WHT	7
28	XA1-J	TB1-10	WHT	5
29	XA1-L	TB1-13	WHT	5
30	XA1-N	TB1-16	WHT	5
31	XA1-1	TB2-6	RED	9
32	XA1-2	TB1-2	GRN	5
33	XA1-3	TB2-7	ORN	9
34	XA1-4	TB1-5	GRN	6
35	XA1-5	SW1-3	BLU	5
36	XA1-6	TB1-8	GRN	5
37	XA1-7	TB1-11	GRN	5
38	XA1-8	TB1-14	GRN	5
39	XA1-9	TB1-17	GRN	5
40	XA2-B	TB1-19	WHT	6
41	XA2-D	TB1-25	WHT	5
42	XA2-F	TB1-28	WHT	5
43	XA2-J	TB1-31	WHT	6
44	XA2-L	TB1-34	WHT	6
45	XA2-R	TB1-22	WHT	8



Table 9-15.5. Gunners Caution Panel Wiring Chart (Cont)

WIRE NO.	FROM CONNECTOR/PIN	TO CONNECTOR/PIN	WIRE COLOR	WIRE LENGTH
46	XA2-1	XA1-1	RED	3
47	XA2-2	TB1-20	GRN	6
48	XA2-3	XA1-3	ORN	3
49	XA2-4	TB1-26	GRN	5
50	XA2-5	XA1-5	BLU	4
51	XA2-6	TB1-29	GRN	6
52	XA2-7	TB1-32	GRN	5
53	XA2-8	TB1-35	GRN	5
54	XA2-13	TB2-3	BLK	8
55	XA2-14	TB2-4	ORN	8
56	XA2-15	TB1-23	GRN	6
57	XA2-8	TB1-37	WHT	7
58	XA3-D	TB1-40	WHT	7
59	XA3-F	TB1-43	WHT	7
60	XA3-J	TB1-46	WHT	5
61	XA3-L	TB1-49	WHT	5
62	XA3-N	TB1-52	WHT	5
63	XA3-1	XA2-1	RED	4
64	XA3-2	TB1-38	GRN	7
65	XA3-3	XA2-3	ORN	4
66	XA3-4	TB1-41	GRN	6
67	XA3-5	XA2-5	BLU	4
68	XA3-6	TB1-44	GRN	6
69	XA3-7	TB1-47	GRN	6
70	XA3-8	TB1-50	GRN	5
71	XA3-9	TB1-53	GRN	5
72	TB1-1	TB1-3	BUS WIRE	A/R
73	TB1-4	TB1-6	BUS WIRE	A/R
74	TB1-7	TB1-9	BUS WIRE	A/R
75	TB1-10	TB1-12	BUS WIRE	A/R
76	TB1-13	TB1-5	BUS WIRE	A/R
77	TB1-16	TB1-8	BUS WIRE	A/R
78	TB1-19	TB1-2	BUS WIRE	A/R
79	TB1-22	TB1-24	BUS WIRE	A/R
80	TB1-25	TB1-27	BUS WIRE	A/R
81	TB1-28	TB1-30	BUS WIRE	A/R
82	TB1-31	TB1-33	BUS WIRE	A/R
83	TB1-34	TB1-36	BUS WIRE	A/R
84	TB1-37	TB1-39	BUS WIRE	A/R
85	TB1-40	TB1-42	BUS WIRE	A/R
86	TB1-43	TB1-45	BUS WIRE	A/R
87	TB1-46	TB1-48	BUS WIRE	A/R
88	TB1-49	TB1-51	BUS WIRE	A/R
89	TB1-52	TB1-54	BUS WIRE	A/R
90	SW1-1	J2-2	BLK	A/R
91	SW1-4	SW2-1	RED	A/R
92	SW2-4	TB2-2	GRN	A/R
93	SW2-2	TB2-1	WHT	A/R
94	SW2-1	TB2-5	RED	A/R
95	XA2-S	SW1-6	ORN	A/R

o. Remove eight screws (46) from sides of panel subassembly (10). Separate annunciator light assembly (45) as far as wiring permits, identify, tag, and resolder wires from annunciator light assembly (45).

p. Disassemble annunciator light assembly (45) as follows:

(1) Remove 12 screws (49), bracket (47), and bracket assembly (48) from annunciator light assembly (45).

(2) Slide housing assemblies (51) and spacers (50) off electrical posts (52).

(3) Remove contact assemblies (53) from housing assemblies (51).

**9-285. CLEANING - GUNNERS CAUTION PANEL.**



**Solvent is highly flammable and toxic. Use only in well ventilated areas away from flame and hot surfaces. Avoid skin contact. Breathing fumes, or directing compressed air at solvent in contact with skin could result in personal injury.**



**Do not use solvent for cleaning nonmetallic parts, electrical wiring, or electronic parts. Solvent could damage parts.**

a. Clean metal parts with dry cleaning solvent (C112).

b. Clean electrical parts with a clean, soft, lint-free cloth moistened with isopropyl alcohol (C64). Allow to air dry.

c. Gently wipe printed circuit boards with a clean, soft, lint-free cloth moistened with isopropyl alcohol (C64). Allow to air dry. Use care to prevent damage to printed circuits.

**9-285.1. INSPECTION - GUNNERS CAUTION PANEL.**

a. Check all parts for general condition and for structural damage that impairs proper system operation.

b. Check internal and external threads for evidence of wear, stripping, and crossthreading.

c. Visually inspect wiring for damaged jacketing and insulation.

d. Visually inspect all soldered connections for looseness and corrosion. Do not stress joint during inspection.

e. Visually inspect printed circuit boards for burned, broken, or damaged circuits.

f. Check printed circuit boards for delamination of metal foil wiring pattern.

**9-286. REPAIR - GUNNERS CAUTION PANEL.**

**NOTE**

**Perform the following steps only as required.**

Repair procedures for caution panel consist of replacement of damaged or defective parts with serviceable ones. Removal and installation, by riveting or soldering, of any part or parts are covered in this paragraph.

a. Replace parts that do not meet inspection requirements. Chase damaged threads.

b. When replacing any part or subassembly secured by rivets, proceed as follows:

(1) Drill out rivets with proper size drill.

(2) Deburr and assemble new parts.

(3) Secure parts with new rivets of size and type indicated in Repair Parts and Special Tools List (RPSTL).

c. When replacing components on printed circuit boards use the following precautions:

(1) Use a low wattage (25 watts or less) soldering iron.

(2) Ground circuit track adjacent to components.

(3) Use heat sinks to avoid overheating adjacent components.

(4) Coat printed circuit boards with insulating compound (C63.1).

d. Finish all visible exterior surfaces, except hardware, with black anodic (C18.1). Refer to figure 9-17.8 for areas not to be finished.

### 3-286.1. ASSEMBLY - GUNNERS CAUTION PANEL.

a. Assemble annunciator light assembly (45, figure 1-17.11) as follows:

(1) Assemble contact assemblies (53) by placing grooved side of swivel arm on latch and install each in housing assemblies (51).

(2) Slide spacers (50) and housing assemblies (51) onto electrical posts (52).

(3) Install bracket (47) and bracket assembly (48) on annunciator light assembly (45) and secure with 12 screws (49).

(4) Solder wires to back of annunciator light assembly (45).

b. Install annunciator light assembly (45) in annunciator housing (61) and secure with eight screws (46).

c. Solder wires to switches (40 and 41). Insert switches (40 and 41) through holes and secure with knurled plain nuts (42).

d. Solder wires to pins on receptacle connectors (43). Install receptacle connectors (43) in annunciator housing (61) and secure with six screws (44).

e. Install connector assembly (32) in annunciator housing (61) as follows:

(1) Insert connector (36) through hole in annunciator housing (61).

(2) Install lug terminal (39) and lockwasher (38) on connector (36). Secure with ferrule nut (37).

(3) Attach lug terminal (33) on connector (36). Secure with screw (34) and lockwasher (35).

f. Install pins and wires in connector (29).

g. Install connector (29). Secure with four screws (31) and self-locking nuts (30).

h. Solder wires to terminals on printed circuit board (22).



**Do not overtighten screws (26) or printed circuit board (22) may crack.**

i. Install sleeve spacers (28) on back of printed circuit board (22). Secure with four screws (26) and lock-spring washers (27). Install printed circuit board (22). Secure with four screws (26) and lock-spring washers (27).



**Use care when installing printed circuit boards (17 and 18) to prevent damage to components.**

j. Install printed circuit boards (17 and 18) in correct receptacle connector (43), component side forward.

k. If identification plate (9) was removed from access cover plate (13) install a new one.

l. Install access cover plate (13). Secure with four screws (14) and two screws (15).

m. Install cover plate (11) and secure with six screws (12).



Do not overtighten screws (8) or light indicating panel (7) may crack.

n. Install light indicating panel (7) on panel subassembly (10) with screws (8).

o. Assemble indicator module (1) as follows:



Ensure correct legends are installed in correct indicator light positions. If legends are installed in wrong positions, aircrew will receive false information during inflight malfunctions.

(1) Install gray filters (4 and 6) and legend (5) in lens retainer (3). Install gray filters (6) with dull side facing out.

(2) Install lens retainers (3) on contact assembly (53).

(3) Rotate indicator module (1) to horizontal position and push into housing assembly (51) until detent is reached.

#### 9-286.2. INSTALLATION - GUNNERS CAUTION PANEL.

a. Connect electrical connector to back of caution panel.

b. Tighten four turnlock stud assemblies to install caution panel in instrument panel of helicopter.

#### 9-287. RPM LIMIT WARNING SYSTEM.

#### 9-288. DESCRIPTION - RPM LIMIT WARNING SYSTEM.

The rpm limit warning system includes a 5 ampere RPM WARN circuit breaker (8CB10) located in dc circuit breaker panel (2A1), a detector unit (1Z3) in left forward side of pilot section, a warning light (P/O 8DS7) on pilot instrument panel, an RPM WARNING switch (1S1) in pilot engine control panel (1A1), electrical wiring, and connectors. Power is supplied by a 28-volt dc essential bus. Also included in the rpm limit warning system are gunner headset terminal board (2301TB2) and pilot headset terminal board (2301TB1). The rpm limit detector, operating on dc power, senses and interprets rotor and engine rpm through connection to tachometer circuits. If the rotor rpm exceeds normal limit, warning light will illuminate. When both rotor or engine rpm reaches low limit, an audio signal is produced in pilot and gunner headsets and warning light is illuminated. For starting and ground operation, audio tone can be turned off by the RPM WARNING switch. Before installation, the rpm warning system detector is adjusted. Readjustment may be required whenever a tachometer generator is replaced, due to tolerances on tachometer components. Replacement of an engine tachometer generator will not require a check of rotor high rpm setting.

**9-289. FUNCTIONAL TEST - RPM LIMIT WARNING SYSTEM.**

**NOTE**

The rpm limit warning system shall be tested upon replacement of the rpm limit warning detector, rotor tachometer generator, or power turbine tachometer generator. Tests shall be conducted with helicopter engine running and prior to alignment. The rpm limit warning detector is aligned during overhaul. If after installation, the detector does not match the dual tachometer readings, perform functional test of the dual tachometer system before changing alignment of detector.

a. Accomplish test for low rpm warning as follows:

(1) Position the RPM WARNING audio switch (1S1) on the pilot engine control panel to RPM WARNING.

(2) Adjust for an engine speed of approximately 98 percent (6468 rpm, corresponds to 318 rotor rpm) and check that the red RPM limit warning light on the instrument panel is off and that the audio warning signal is not audible in the pilot or gunner headsets.

(3) Decrease engine speed very slowly to the point where the RPM limit warning light illuminates and a swept-frequency audio warning signal (series or audio bursts) is audible in the pilot and gunner headsets. This point should beat engine and/or rotor speed of  $94 \pm 1$  percent (engine:  $6200 \pm 100$  rpm, rotor:  $305 \pm 5$  rpm).

(4) Position the RPM WARNING audio switch (1S1) to OFF. The audio signal in the headsets should cease.

(5) Adjust for engine and/or rotor speed below 91 percent (engine: 6000 rpm, rotor: 295 rpm). The RPM limit warning light should be illuminated, but the audio warning signal should not be audible in the pilot and gunner headsets.

(6) Increase the engine speed and verify that the RPM limit warning light extinguishes within the limits of  $94 \pm 1$  percent for both engine and rotor (engine:  $6200 \pm 100$  rpm, rotor  $305 \pm 5$  rpm). The RPM WARNING audio switch should automatically return to RPM WARNING position.

b. Accomplish test for high rpm warning as follows:

(1) Position the RPM WARNING audio switch (1S1) to the RPM WARNING position.



Do not exceed 27 percent (15 psi) torque pressure or 103 percent engine speed.

(2) With the rotor in flat pitch and the GOV AUTO/EMER governor switch set to EMER, slowly increase throttle until the RPM warning light illuminates. The warning light should illuminate at a rotor speed of  $103 \pm 1$  percent (between 329 and 334 rpm, corresponds to engine speed between 6700 and 6800 rpm). The audio warning signal should not be audible in the pilot and gunner headsets.

**9-290. ALIGNMENT - RPM LIMIT WARNING SYSTEM.**

**NOTE**

Perform alignment of low or high rpm limit warning, whichever is applicable, if system does not meet test requirements of paragraphs 9-289.

a. Perform alignment of low rpm limit warning as follows:



Use caution in making adjustment as excessive turning of slotted adjustment can damage box.

**NOTE**

To increase the percent rpm at which the warning light will illuminate, turn clockwise ROTOR LOWER LIMIT (R1), ROTOR HIGH LIMIT (R2), or ENGINE LOW LIMIT (T3) slotted adjustments. One half turn of the potentiometer shaft will cause a change of approximately 1.5 percent rotor or engine rpm.

(1) Position ROTOR NORMAL/DISABLE switch to DISABLE to deactivate the rotor low rpm signal.

(2) Start helicopter and increase engine speed to approximately 98 percent (6468 rpm, corresponds to 318 rotor rpm).

(3) Slowly decrease engine speed to 92 percent (6072 rpm).

(4) If, following step (3), the RPM limit warning light is illuminated, turn ENGINE LOWER LIMIT adjustment slowly counterclockwise until the warning light extinguishes and then very slowly clockwise until the warning light again illuminates. If, following step (3), the RPM limit warning light is extinguished, turn the ENGINE LOWER LIMIT adjustment slowly clockwise until the warning light just illuminates.

(5) Vary the engine speed slowly above and below 92 percent (6072 rpm) while observing the warning light. Verify that the warning occurs at an engine speed of  $94 \pm 1$  percent ( $6200 \pm 100$  rpm); if not, repeat steps (3), (4), and (5).

(6) Position the ROTOR NORMAL/DISABLE switch to NORMAL and the ENGINE NORMAL/DISABLE switch to DISABLE to deactivate the engine low rpm signal.

(7) Adjust for a rotor speed of 92 percent (298 rpm).

(8) If, following step (7), the warning light is illuminated, turn ROTOR LOWER LIMIT adjustment slowly counterclockwise until the warning light just extinguishes, then very slowly clockwise until the light again illuminates. If, following step (7), the warning light is extinguished, turn ROTOR LOWER LIMIT adjustment very slowly clockwise until the light just illuminates.

(9) Vary rotor speed above and below 92 percent (298 rpm) while observing the warning light. Verify that warning occurs at  $94 \pm 1$  percent ( $305 \pm 5$  rpm). If light does not illuminate, repeat steps (7), (8), and (9).

(10) Return the ENGINE NORMAL/DISABLE switch to NORMAL.

b. Perform alignment of rotor high rpm limit warning as follows:



**Use caution in making adjustments as excessive turning of slotted adjustment can damage box.**

**Do not exceed 15 psi engine torque.**

(1) With the rotor in flat pitch and GOV AUTO/EMER switch set to EMER, slowly increase throttle until rotor speed is 102.3 percent (331.4 rotor rpm, corresponds to engine speed of 6750 rpm).

(2) If, following step (1), the warning light is illuminated, turn ROTOR HIGH LIMIT adjustment clockwise until the light just extinguishes, then very slowly counterclockwise until the light just illuminates. If, following step (1), the warning light is extinguished, turn ROTOR HIGH LIMIT adjustment very slowly counterclockwise until the warning light just illuminates,

(3) Vary the engine speed to verify that the warning light illuminates and that audio warning does not occur at a rotor speed of  $103 \pm 1$  percent (329 to 334 rotor rpm, corresponds to engine speed between 6700 and 6800 rpm). If warning light does not illuminate, repeat steps (1), (2), and (3).

(4) Repeat low and high rpm warning functional tests as specified in paragraph 9-289.

(5) Close detector cover.

### 9-291. TROUBLESHOOTING - RPM LIMIT WARNING SYSTEM.

Refer to paragraph F-9 in Appendix F for wiring diagrams. Use table 9-16 and perform checks as necessary to isolate trouble. In the following table, tripped circuit breakers are omitted from indications of trouble. Such trouble is usually easily detected and corrected. Broken wiring is always a probable cause of circuit malfunction of failure and has not been included.

## NOTE

**Before you use this table, be sure you have performed all normal operational checks. If you have a malfunction which is not listed in this table, notify the next higher level of maintenance.**

**Table 9-16. Troubleshooting RPM Limit Warning System**

---

CONDITION

## TEST OR INSPECTION

**CORRECTIVE ACTION**

1. No audio tone is present in pilot or copilot headsets; engine not running and rpm warning light is illuminated.

STEP 1. Check for defective RPM WARNING switch (1S1).

**Replace switch if defective (paragraph 9-16).**

STEP 2. Check for defective rpm limit warning detector (1Z3).

**Replace rpm limit warning detector if defective (paragraph 9-292).**

2. Placing RPM WARNING switch (1S1) to OFF does not eliminate audio tone in headsets.

STEP 1. Check for defective RPM WARNING switch (1S1).

**Replace switch if defective (paragraph 9-16)**

3. Rpm warning light (8DS7) does not illuminate when engine is not running. Audio tone present in headsets.

STEP 1. Check for defective rpm limit warning detector (1Z3).

**Replace rpm limit warning detector if defective (paragraph 9-292).**

4. Rpm warning light (8DS7) does not illuminate, no audio tone present in headsets when engine is not running.

STEP 1. Check for defective RPM WARN circuit breaker (8CB10).

**Replace circuit breaker if defective (paragraph 9-23).**

STEP 2. Check for defective rpm limit warning detector (1Z3).

**Replace rpm limit warning detector if defective (paragraph 9-292).**

---

**9-292. RPM LIMIT WARNING DETECTOR**

**9-293. DESCRIPTION - RPM LIMIT WARNING DETECTOR.**

The rpm limit warning detector (1Z3), operating on dc power from the essential bus senses and interprets rotor and engine rpm through connection to tachometer circuits. If rotor exceeds normal limit, power is furnished through the detector to illuminate the rpm warning light (8DS7). When either rotor or engine rpm reaches low limit, the detector produces an audio signal in the pilot and copilot headsets and illuminates the rpm warning light.

**9-294. CLEANING RPM LIMIT WARNING DETECTOR.**

a. Remove moisture and loose dirt with a clean, soft cloth.

**WARNING**

**Cleaning solvent is flammable and toxic. Provide adequate ventilation. Avoid prolonged breathing of solvent vapors and contact with skin or eyes.**

b. Remove grease, fungus, and ground-in dirt with a clean, lint-free cloth dampened with dry cleaning solvent (C112).

c. Remove dirt from electrical connectors with a bristle brush.

**9-295. INSPECTION - RPM LIMIT WARNING DETECTOR.**

a. inspect rpm limit warning detector for cracked or distorted case.

b. Check for bent or broken connector pins.

c. Check for proper operation.

**9-296. BENCH TEST AND ADJUSTMENT - RPM LIMIT WARNING DETECTOR. (AVIM).**

a. Setup bench test equipment as shown in figure 9-18.

**NOTE**

**The rpm test set may be locally fabricated. Refer to paragraph F-9 for index to wiring diagrams.**

9-92 Change 18

**The pilot and copilot (gunner) audio outputs are loaded within the test set so that an oscilloscope may be used to monitor audio signals. The scope input cable is connected to a scope input switch that allows selection of pilot or copilot (gunner) audio output.**

b. Use equipment shown in figure 9-18 and test each rpm limit warning detector as follows:

**NOTE**

**For Saturn detectors, step (15) checks the engine channel tachometer circuits. For other models go to step (16).**

(1) Remove jumper or loosen detector cover strip screws and move cover strips to expose adjustment potentiometers.

**NOTE**

**For Saturn detectors, step (20) checks the engine channel tachometer circuits. For other models go to step (21).**

(2) Remove jumper or connect detector to the bench test equipment as shown in figure 9-18. Set initial control positions on the test set as follows:

CONTROL

POSITION

PWR ON/OFF	OFF
ENGINE SPEED	FULLY COUNTERCLOCKWISE
ROTOR SPEED	FULLY COUNTERCLOCKWISE
AUDIO ON/OFF	ON
SCOPE INPUT	PILOT

(3) Energize the test equipment and allow a sufficient warmup period.

(4) Apply 27.5 Vdc power to the DC power packs on the front of the test set. Observe that the warning light on the test set is illuminated and that a sweeping audio signal is displayed on the oscilloscope for both the PILOT and COPILOT (GUNNER) positions of the scope input switch.

(5) Connect a headset to the COPILOT (GUNNER) phone jack and determine that the aural signal is of good quality, Disconnect headset.

(6) Repeat step (5) with headset plugged into the PILOT phone jack.



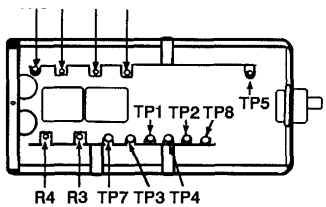
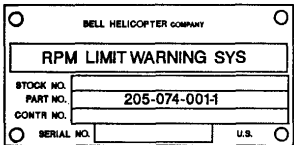

VIEW LOOKING DOWN ON TEST POINTS COVER OPEN

Figure 9-18. BHC Model RPM Warning Control

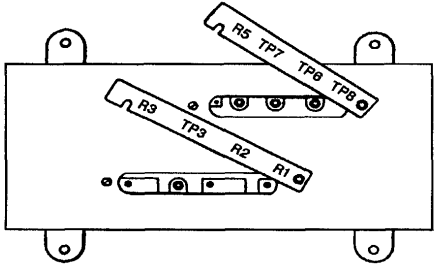

VIEW LOOKING DOWN ON TEST POINTS

Figure 9-18.1. Saturn Model RPM Limit Warning Detector

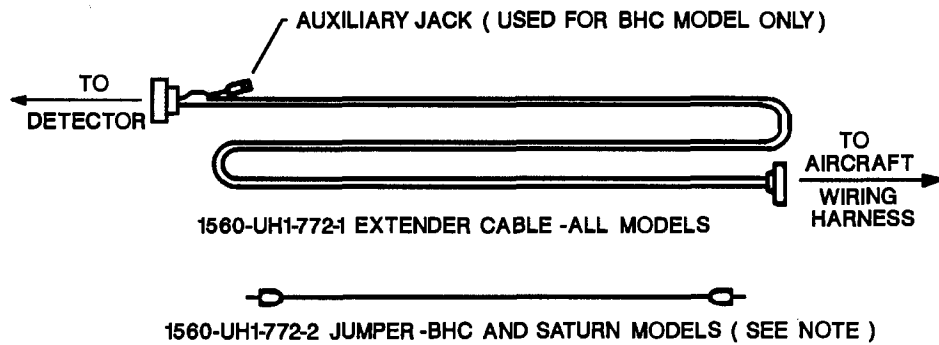

**NOTE:**  
 Existing test sets using an ENGINE-NORMAL-ROTOR (E-N-R) switch may be used. Connect as shown in Detail A for BHC models or position switch to ROTOR and use test leads only as a jumper for SATURN models.

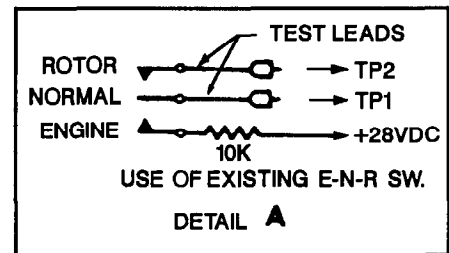

Figure 9-18.2. Cables for Alignment of Rpm Limit Warning Detector

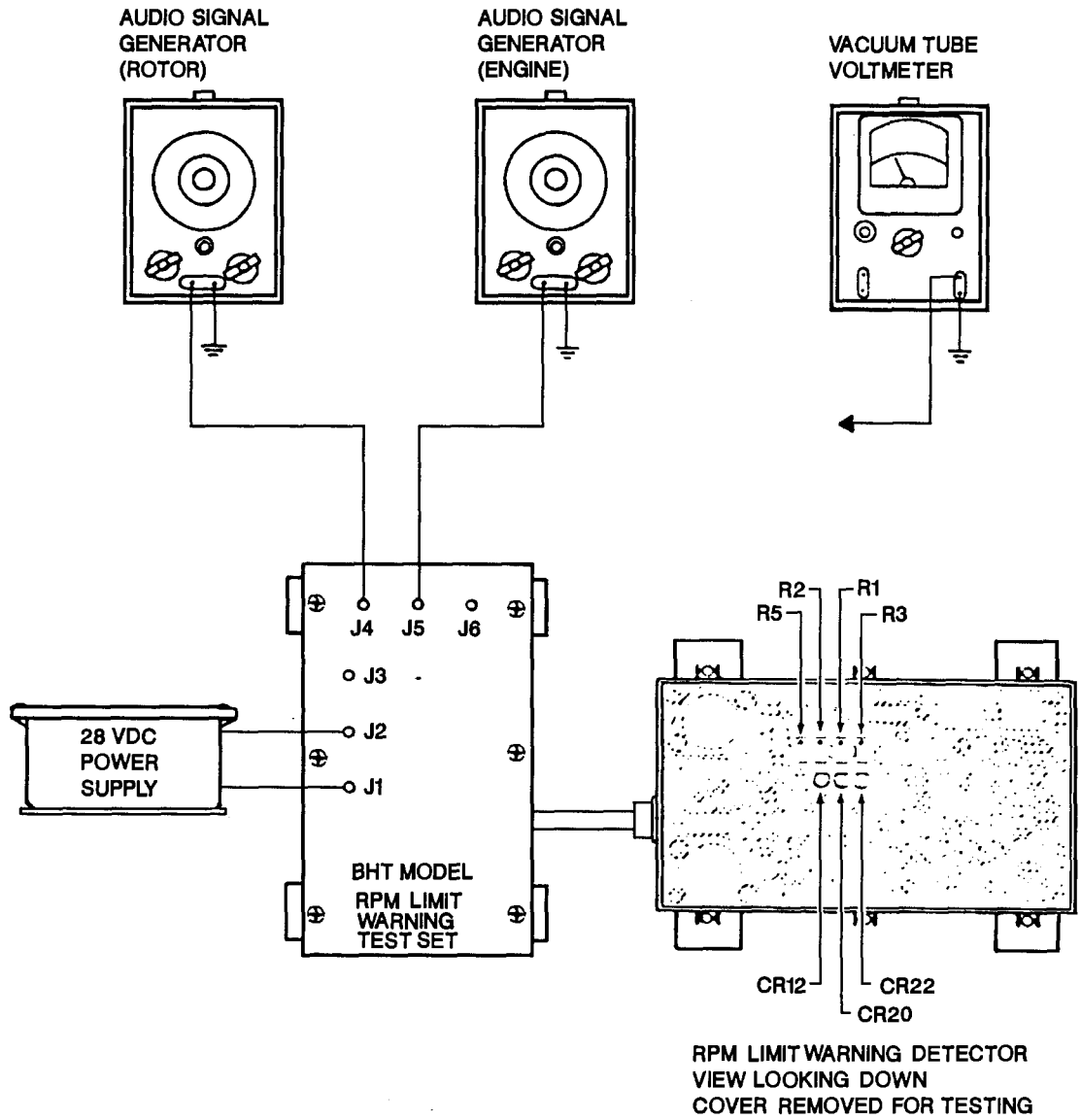

Figure 9-18.3. Bench Test Set Up for BHT 205-074-033-101 Rpm Limit Warning Detector

(7) Disable engine circuit to align R11-ROTOR LOWER LIMIT.

(8) Adjust test set for a simulated rotor speed of 300 rpm and an engine speed of 6100 rpm. If the warning light is illuminated, adjust R1-ROTOR LOWER LIMIT counterclockwise until the light just extinguishes.

(9) Adjust R1-ROTOR LOWER LIMIT clockwise very slowly until the light just illuminates. With the light illuminated, an audio signal must be displayed on the oscilloscope for both the PILOT and COPILOT (GUNNER) position of the scope input switch.

(10) Position audio ON/OFF switch to OFF. The sweeping audio signal must cease.

(11) Slowly increase simulated rotor speed through 300 rpm. Observe that the audio switch automatically returns to the ON position when the warning light extinguishes.

(12) Increase simulated rotor speed to 334 rpm. If the warning light is illuminated, adjusted R2-ROTOR HIGH LIMIT clockwise until the light just extinguishes.

(13) Adjust R2-ROTOR HIGH LIMIT very slowly counterclockwise until the light just illuminates. Observe that an audio signal is not displayed on the oscilloscope for either PILOT or COPILOT (GUNNER) positions of the scope input switch.

(14) Adjust for a simulated rotor speed of 324 rpm. Observe that the warning light is extinguished and that audio signal is not displayed on the oscilloscope for either the PILOT or COPILOT positions of the scope input switch.

(15) Momentarily adjust for a simulated engine speed of 0 rpm. Observe that the warning light illuminates and that audio signal is displayed on the oscilloscope for both PILOT and COPILOT positions of the scope input switch.

(16) Reposition switch used to disable engine circuits in step (7) and disable rotor circuit to align R3-ENGINE LOWER LIMIT.

(17) With the simulated rotor speed still at 324 rpm, adjust for a simulated engine speed of 6200 rpm. If the warning light is illuminated adjust R3-ENGINE LOWER LIMIT counterclockwise until the light just extinguishes.

(18) Adjust R3-ENGINE LOWER LIMIT clockwise until the light just illuminates, While the

warning light is illuminated, observe that audio signal is displayed on the oscilloscope for both the PILOT and COPILOT (GUNNER) positions of the scope input switch.

(19) Adjust for a simulated engine speed of 6400 rpm. Observe that the warning light is extinguished and that the audio signal is not displayed on the oscilloscope for either the PILOT or COPILOT (GUNNER) positions of the scope input switch.

#### NOTE

**Step (19) checks proper function only. The engine high limit potentiometer R4 is factory adjusted fully clockwise and is not to be adjusted.**

(20) Repeat step (18) at a simulated engine speed of 7000 rpm.

(21) Position switch used to disable rotor circuit in step (15). Adjust rotor and engine speed controls on test set fully counterclockwise.

(22) Position scope input switch to PILOT and adjust R5-AUDIO for a waveform of 0.5 volts peak-to-peak across an 8 ohm load. Position scope input switch to COPILOT (GUNNER) and observe that the indicated waveform is not less than 0.25 volts peak-to-peak and not more than 0.75 volts peak-to-peak across an 8 ohm load.

(23) Disconnect detector from test set and reassemble unit.

#### 9-297. REMOVAL - RPM LIMIT WARNING DETECTOR.

- a. Disconnect electrical connector.
- b. Remove attaching hardware and remove detector.

#### 9-298. REPAIR - RPM LIMIT WARNING DETECTOR.

Repair is limited to replacement of defective unit. Return defective unit to depot for repair.

#### 9-299. INSTALLATION - RPM LIMIT WARNING DETECTOR.

- a. Position detector into place and install mounting hardware.
- b. Connect connector.

**9-299.1. SKID LANDING LIGHT SYSTEM.**

**9-299.2. DESCRIPTION - SKID LANDING LIGHT SYSTEM.**

The skid landing light circuit consists of a 20 ampere SKID LDG LT circuit breaker located in the dc circuit breaker panel, an on/off switch located on the left side of the pilots cockpit aft of the ashtray, and a landing light mounted on the left side of the forward crosstube assembly.

**9-299.3. FUNCTIONAL TEST - SKID LANDING LIGHT SYSTEM.**

Close the SKID LDG LT circuit breaker. Plact

the SKID LDG LT switch in the ON position. Check that the skid landing light is energized. Return switch to OFF and open circuit breaker.

**9-299.4. TROUBLESHOOTING - SKID LANDING LIGHT SYSTEM.**

Refer to paragraph F-9 for wiring diagram. Use table 9-16.1 and perform checks as necessary to isolate trouble. In table 9-16.1, tripped circuit breakers are omitted from indications of trouble. Such trouble is usually easily detected and corrected. Broken wiring is always a probable cause of a circuit malfunction or failure and has not been included.

**NOTE**

**Before using table 9-16.1, be sure you have performed the functional test.**

**Table 9-16.1. Troubleshooting Skid Landing Light System**

CONDITION

TEST OR INSPECTION

**CORRECTIVE ACTION**

1. Skid landing light fails to illuminate.

STEP 1. Check if bulb is burned out and heck lamp connections for corrosion.

**Clean lamp connections and/or replace bulb.**

STEP 2. With the SKID LDG LT circuit breaker closed and the SKID LDG LT switch in the ON position, check for 28 Vdc essential bus voltage on both sides of switch.

**Replace switch if voltage is preseent on wire SLB12 terminal of switch but not on wire SLC12 terminal.**

2. Skid landing light does not turn off.

**Replace switch.**

**9-299.5. SKID LANDING LIGHT.**

**9-299.6. CLEANING - SKID LANDING LIGHT.**

a. Remove moisture and loose dirt with a clean soft cloth.

**WARNING**

**Cleaning solvent is flammable and toxic. Provide adequate ventilation. Avoid prolonged breathing of solvent vapors and contact with skin or eyes.**

b. Remove grease, fungus, and ground-in dirt with a clean, lint-free cloth dampened with dry cleaning solvent (C112).

c. Remove dirt from electrical connections with a bristle brush.

**9-299.7. INSPECTION - SKID LANDING LIGHT.**

Inspect light for corroded lamp terminals, shorted or broken wires, burned out lamp bulb or improper security of light assembly.

**9-299.8 REMOVAL-SKID LANDING LIGHT.**

Remove screws and ring securing bulb in canopy and remove bulb. Disconnect wires from bulb terminals. Loosen compression nut on back of canopy and remove wires. Cover wire ends with tape (C121). Remove skid landing light assembly from crosstube.

**9-299.9 REPAIR-SKID LANDING LIGHT.**

Replace faulty or damaged component parts.

**9-298.10 INSTALLATION - SKID LANDING LIGHT.**

a. Secure skid landing light assembly to forward crosstube. Remove protective tape from wires. Insert wires through insulation sleeve RNF-100-1 (3 inches long) and secure wires in light canopy. Position insulation sleeve over compression nut and apply heat as necessary. Connect wires to bulb terminals and place bulb in light canopy. Install bulb retaining ring.

b. Check operation of light.

**9.299.11. OIL DEBRIS DETECTION SYSTEM (ODDS) (HELICOPTERS WITH MWO 1-1520-236-50-30)**

**9.299.12. DESCRIPTION.** The oil debris detection system (ODDS) provides for prediction/detection of impending failures of oil-wetted components: engine, transmission, and 42° and 90° tailrotor gearboxes. The system also improves oil filtration, reduces wear on seals, reduces unscheduled removal of oil-wetted components, and reduces nuisance chip indications caused by normal-wear particles on detector gaps. Twenty-eight volt dc for system operation is obtained from the essential bus through 5-ampere ODDS circuit breaker.

a. Powerplant oil system components:

(1) Oil separator (Lubriclone) in engine compartment (paragraph 4-61 .2).

(2) Oil filter, with 3-micron element, in engine compartment (paragraph 4-61. 14).

(3) Chip detector at bottom of oil separator. Detector is wired to ENG CHIP caution light.

b. Drive system components:

(1) Debris monitor in transmission sump. Monitor replaces pre-ODDS conventional filter.

(2) External filter, with 3-micron element, bracket-mounted on transmission case. Filter replaces pre-ODDS 25 micron filter.

(3) Three chip detectors, one in debris monitor and one each in 42° and 90° gearboxes. Detectors are wired to TRANS CHIP, 42° CHIP, and 90° CHIP caution lights.

c. Electrical system component: Power module, on pilot's right console provides electrical power to pulse (burn) away ferrous (iron or steel) debris less than 0.005 inch in cross section. Larger debris will not pulse away, but bridges chip gap and closes the circuit to caution lights.

**9-199.13. FUNCTIONAL TEST - ODDS**

a. Apply external power to helicopter.

b. Check that ODDS and CAUTION LIGHTS circuit breakers are closed.

c. At each chip detector or debris monitor listed below (four locations), perform functional test as follows:

- (1) Disconnect cable plug.
- (2) Remove chip detector.
- (3) Connect chip detector to cable plug.
- (4) Ground body of detector to clean unpainted surface of airframe. Use a jumper wire.
- (5) Place paper clip or similar iron or steel object across chip gap of detector. The paper clip will draw a spark; caution light listed and MASTER CAUTION light shall come on.

(6) Remove paper clip. Caution capsule shall go out. MASTER CAUTION light will go out when pressed. Separate chip detector from ground.

(7) Disconnect cable plug from chip detector.

(8) Install and connect chip detector probe. Safety wire each chip detector connector with lockwire (C137).

**9-299-14. TROUBLESHOOTING - ODDS**

Refer to paragraph F-9 in Appendix F for wiring diagram. Use Table 9-16.2 and perform checks as necessary to isolate trouble. In the following table, tripped circuit breakers are omitted from indications of trouble. Such trouble is usually easily detected and corrected.

<u>Chip Detector</u>	<u>Location</u>	<u>Caution Capsule</u>
1D851* (two chip gaps)	Transmission	TRANS CHIP
1B833	42° Gearbox	42° CHIP
1B833	90° Gearbox	90° CHIP
B4443B	Engine	ENG CHIP

**NOTE**

**Before you use this table, be sure you have performed all normal operational checks. If you have a malfunction which is not listed in this table, notify the next higher level of maintenance.**

\* Test each chip gap separately.

Table 9-16.2. Troubleshooting ODDS

**CONDITION**

**TEST OR INSPECTION**

**CORRECTIVE ACTION**

1. During test, ENG CHIP caution light does not come on when pin 1 of oil separator cable plug is shorted to ground.

STEP 1. If master caution light came on, replace ENG CHIP lamps or troubleshoot caution panel.

**If master caution light did not come on, check continuity of wire W10C18 between pin 1 of oil separator cable plug and pin 8A2P1-J at caution panel. Repair wiring.**

2. During test, 42° CHIP caution light does not come on when pin 1 of chip detector cable plug is shorted to ground.

STEP 1. If master caution light came on, replace 42° CHIP lamps or trouble shoot caution system.

**If master caution light did not come on, check continuity of wire W8C20 between pin 1 of chip detector cable plug and pin 8A2P1-K at caution panel. Repair wiring.**

Table 9-16.2. Troubleshooting ODDS

CONDITION

TEST OR INSPECTION

**CORRECTIVE ACTION**

3. During test, 90° CHIP caution light does not come on when pin 1 of chip detector cable plug is shorted to ground.

STEP 1. If master caution light came on, replace 90° CHIP lamps or troubleshoot caution system.

**If master caution light did not come on, check continuity of wire W9C20 between pin 1 of debris monitor cable plug and pin 8A2P1-L at caution panel. Repair wiring.**

4. During test, TRANS CHIP caution light does not come on when pin 1 of debris monitor cable plug is shorted to ground.

STEP 1. If master caution light came on, replace TRANS CHIP lamps or trouble shoot caution system.

**If master caution light did not come on, check continuity of wire W7C20 between pin 1 of debris monitor cable plug and pin 8A2P1-M at caution panel. Repair wiring.**

5. Debris collects across chip gap of any one of chip detectors.

STEP 1. Clean chip detector. Short across chip gap with screw driver or paper clip and check for spark.

**Check power module if there is no spark.**

STEP 2. Disconnect cable plug at power module. Check for 28V dc across pin 1 (+) and pin (2). **Replace power module if voltage is present. Troubleshoot wiring to ODDS circuit breaker if there is no voltage.**

6. Caution light stays on when chip gap is clean.

STEP 1. Remove chip detector probe or remove debris monitor. Use multimeter to check resistance across chip gap. Minimum resistance is 1 megohm

**Replace probe if resistance is less than 1 megohm.**

STEP 2. If probe resistance is more than 1 megohm. troubleshoot wiring. Repair defective wiring.



**9-299.15. ODDS POWER MODULE**

**9-299.16. DESCRIPTION** - A four-channel power module (8A3, figure 9-8) for oil debris detection system (ODDS) is just aft of the caution panel on the pilot's right console, below the ADF control. Power module responds to iron or steel chips across four chip detectors by pulsing them. If chips are less than about 0.005 inch in cross-section, the module will pulse (burn) them away before caution light can respond. If chips are larger, they will not burn away; they will bridge the chip gap and light a caution light. The power module is connected to chip detectors in oil system or oil supply of engine, transmission, and two tail-rotor gearboxes. Components of power module are encapsulated in a 3 x 3 x 1-1/2-inch black box. Twenty-eight volt dc for operation is obtained from essential bus through ODDS circuit breaker. Connections to circuits are made through a 12-pin electrical receptacle.

**9-299.17. REMOVAL - POWER MODULE**

- a. Remove the adf control (TM 11-1520-236-23).
- b. Disconnect cable plug.
- c. Remove four screws and washers and remove power module.

**9-299.18. INSTALLATION - POWER MODULE**

- a. Position the power module on pilot's right console, receptacle outboard.
- b. Install four screws and washers.
- c. Connect the cable plug to the power module.
- d. Test the system (paragraph 9-299.13).
- e. Install the adf control (TM 11-1520-236-23).



**9-300. POSITION LIGHTS SYSTEM.**

**9-301. DESCRIPTION - POSITION LIGHTS SYSTEM.**

The position lights circuit includes a 5 ampere POS(N) LT circuit breaker (8CB1) located in dc circuit breaker panel (2A1), and two selector switches (8S1 and 8S2), located on the pilot lighting control panel (10A1). A flasher (821) is mounted in pilot section, right well. The position lights consist of a red light (8DS1), a green light (8DS2), and white lights (8DS3) (LH) and 8DS4) (RH). The red light is mounted in left wing tip, the green light is mounted in right wing tip, and the white lights are located on either side of tail boom. Switch (8S1) controls OFF/STEADY/FLASH and switch (8S2) controls BRT/DIM position. The dimming circuit is provided by a dimming resistor (8R1) located on 1TB3, which is located in pilot section right well.

**9-302. FUNCTIONAL TEST - POSITION LIGHTS SYSTEM.**

a. Close POS(N) LT PWR circuit breaker (8CB1). Place POSITION LT switch (8S1) to STEADY. Position BRT/DIM switch (8S2) to BRT. Check that the red and green position lights and tail lights are energized and are on bright.

b. Position BRT\DIM switch to DIM. Check that the position lights are dim.

c. Position POSITION LT switch to FLASH. Check that the red and green position lights, and the tail lights are all on dim and flash at a rate of approximately 80 ± 10 cycles per minute.

d. Position BRT\DIM switch to BRT and repeat step c. Check that lights flash as before except that lights are brighter than that observed in preceding step c.

e. Open POSN LT circuit breaker (8CB1).

**9-303. TROUBLESHOOTING - POSITION LIGHTS SYSTEM.**

Refer to paragraph F-9 in Appendix F for wiring diagram. Use Table 9-17 and perform checks as necessary to isolate trouble. In the following table, tripped circuit breakers are omitted from indications of trouble. Such trouble is usually easily detected and corrected. Broken wiring is always a probable cause of circuit malfunction or failure and has not been included.

**NOTE**

**Before you use this table, be sure you have performed all normal operational checks. If you have a malfunction which is not listed in this table, notify the next higher level of maintenance.**

**Table 9-17. Troubleshooting Position Lights System**

---

CONDITION
TEST OR INSPECTION
CORRECTIVE ACTION
1. Position lights (8DS1, 8DS2, 8DS3 and 8DS4) fail to illuminate brightly.
STEP 1. With switch (8S1) to STEADY and switch (8S2) to BRT check for 28 Vdc nonessential bus voltage on terminals 5 and 6 of switch (8S1).
<b>Replace switch (8S1) if voltage is not present on terminal 6 (paragraph 9-16).</b>

Table 9-17. Troubleshooting Position Lights System (Cont)

CONDITION

TEST OR INSPECTION

**CORRECTIVE ACTION**

STEP 2. With switch (8S1 ) to STEADY and switch (8S2) to BRT, check for 28 Vdc nonessential bus voltage on terminals 1 and 2 of switch (8S2).

**Replace switch (8S2) if voltage is not present on terminal 1 (paragraph 9-16).**

2. One light is dim or intermittent.

STEP 1. Determine if light is properly grounded.

**Remove light, clean ground, replace light.**

3. One light does not illuminate.

STEP 1. Check whether bulb is burned out and check lamp socket for corrosion.

**Clean lamp socket and/or replace light (paragraph 9-304).**

4. Lights fail to dim when switch (8S2) is placed to dim.

STEP 1. Check dimming resistor (8R1).

**Replace dimming resistor (8R1) if it is defective (paragraph 9-16).**

5. Lights fail to flash when switch (8S1) is placed to FLASH.

STEP 1. Determine if position lights flasher is defective.

**Replace flasher if defective (paragraph 9-310).**

**9-304. POSITION LIGHTS.**

**9-305. CLEANING - POSITION LIGHTS.**

a. Remove moisture and loose dirt with a clean, soft cloth.

b. Remove grease, fungus, and ground-in dirt with a clean, lint-free cloth dampened with dry cleaning solvent (C112).

c. Remove dirt from electrical connectors with a bristle brush.



**Cleaning solvent is flammable and toxic. Provide adequate ventilation. Avoid prolonged breathing of solvent vapors and contact with skin or eyes.**

**9-306. INSPECTION - POSITION LIGHTS.**

Inspect lights for corroded lamp socket terminals, shorted or broken wires, cracked lens, burned out lamp bulbs, or improper bonding of light case to airframe.

**9-307. REMOVAL – POSITION LIGHTS.**

- a. Check that all electrical power is OFF.
- b. Remove cover retaining screw. Remove screws attaching light assembly to bracket, pull assembly from helicopter, and disconnect wire from light. Lift light assembly from helicopter. Cover loose wire with tape (C121).

**9-308. REPAIR POSITION LIGHTS.**

Replace faulty or damaged component parts (lens, lamp bulbs, etc.) If light case is damaged beyond repair, complete unit must be replaced.

**9-309. INSTALLATION — POSITION LIGHTS.**

- a. Remove tape from wire and connect wire to light. Secure light to adapter bracket with screws. Install cover with screw.
- b. Check operation of light.

**9-310. POSITION LIGHTS FLASHER.**

**9-311. CLEANING – POSITION LIGHTS FLASHER.**

- a. Remove moisture and loose dirt with a dean, soft cloth.



Cleaning solvent is flammable and toxic. Provide adequate ventilation. Avoid prolonged breathing of solvent vapors and contact with skin or eyes.

- b. Remove grease, fungus, and ground-in dirt with a dean, lint-free cloth dampened with dry cleaning solvent (C112).
- c. Remove dirt from electrical connectors with a bristle brush.

**9-312. INSPECTION – POSITION LIGHTS FLASHER.**

Inspect flasher case for dents or damage that could impair normal operation of the unit. Check connector for broken or corroded pins and cracked inserts.

**9-313. REMOVAL – POSITION LIGHT FLASHER.**

- a. Ensure all electrical power is OFF.
- b. Disconnect electrical connector. Remove mounting hardware and lift from compartment.

**9-314. REPAIR — POSITION LIGHTS FLASHER.**

Replace item if inspection requirements are not met.

**9-315. INSTALLATION — POSITION LIGHTS FLASHER.**

- a. Position flasher in compartment and install mounting hardware.
- b. Connect electrical connector. Check for proper operation.

**9-315.1. NVG POSITION LIGHTS SYSTEM.**

**9-315.2. DESCRIPTION – NVG POSITION LIGHTS SYSTEM.**

The NVG position lights circuit consists of a 5 ampere NVG POSITION LT circuit breaker located in the dc circuit breaker panel, a six position switch (OFF and 5 levels of brightness) located on the pilots ECS/LTG panel and five position lights (one on each wingtip, one on each aft light fairing, and one on the tail fin fairing). The position lights are compatible for use with the night vision goggles.

**9-315.3. FUNCTIONAL TEST - NVG POSITION LIGHTS SYSTEM.**

**NOTE**

Use locally fabricated NVG light test set.

Close the NVG POSITION LT circuit breaker. With the NVG POSITION LIGHTS LT switch in the OFF position, all NVG position lights should be off. As the NVG POSITION LT switch is rotated through the other five positions, all NVG position lights should be energized and increase in brightness with each step to the BRT position. Rotate the switch back through five steps, all NVG position lights should decrease in brightness and should be de-energized in the OFF position.

**NOTE**

Before using table 9-17.1, be sure you have performed the functional test.

**Table 9-17.1. Troubleshooting NVG Position Lights System**

**CONDITION**

**TEST OR INSPECTION**

**CORRECTIVE ACTION**

1. Individual NVG position light fails to illuminate.

**STEP 1.** Check if light is burned out.

Replace NVG position light assembly (paragraph 9-315.8).

2. All NVG position lights fail to illuminate.

**STEP 1.** With the NVG POSITION LT circuit breaker closed and the NVG POSITION LT switch in the BRT position, check for 28 Vdc nonessential bus voltage on pins 11 and 16 of NVG position light switch.

Replace NVG POSITION LT switch if voltage is present on pin 11 but not present on pin 16.

3. No brightness differential between two or more steps of NVG position light switch.

**STEP 1.** With the NVG POSITION LT circuit breaker closed and the NVG POSITION LT switch selecting the dimmer position, measure and record the Vdc level at pin 16 of NVG position light switch. Rotate NVG position light switch through each non-differentiating step and record the Vdc level at pin 16 of NVG position light switch.

Replace NVG POSITION LT switch if there is no voltage increase between steps.

4. NVG position lights do not turn off.

Replace NVG POSITION LT switch.

**9.315.4. TROUBLESHOOTING - NVG POSITION LIGHTS SYSTEM.**

Refer to paragraph F-9 for wiring diagram, Use table 9.17.1 and perform checks as necessary to isolate trouble. Such trouble is usually easily detected and corrected. Broken wiring is always a probable cause of circuit malfunction or failure and has not been included.

**9-315.5. NVG POSITION LIGHTS.**

**9-315.6. CLEANING — NVG POSITION LIGHTS.**

- a. Remove moisture and loose dirt with a clean soft cloth.

**WARNING**

Cleaning solvent is flammable and toxic. Provide adequate ventilation. Avoid prolonged breathing of solvent vapors and contact with skin or eyes.

b. Remove grease, fungus, and ground-in dirt with a clean, lint-free cloth dampened with dry cleaning solvent (C112).

c. Remove dirt from electrical connections with a bristle brush.

**9-315.7. INSPECTION - NVG POSITION LIGHTS.**

Inspect lights for corrosion, shorted or broken wires, cracked lens or frame, burned out light, or improper security of light assembly to airframe.

**9-315.8. REMOVAL - NVG POSITION LIGHTS.**

Remove two screws, washers, and nuts. Disconnect wire splices and remove NVG position light.

**9-315.9. REPAIR-NVG POSITION LIGHTS.**

Replace faulty or damaged components.

**9-315.10. INSTALLATION - NVG POSITION LIGHTS.**

Remove excess sealant from around fixture location. Apply bead of sealing compound (C107.5) and install NVG position lights with two screws, washers, and nuts. Connect wire splices.

**9-316. ANTI COLLISION LIGHT SYSTEM.****9-317. DESCRIPTION - ANTICOLLISION SYSTEM.**

The anticollision light circuit consists of a circuit breaker (8CB2), a switch (8S3), and anticollision light assembly (8DS5). Anticollision light is installed on pylon fairing. Circuit breaker and switch are on dc circuit breaker panel (2A1) and pilot lighting control panel (10A1) respectively,

**9-318. FUNCTIONAL TEST - ANTICOLLISION LIGHT SYSTEM.**

a. Close ANTI-COLL LT circuit breaker.

b. Position ANTI-COLL LT switch (8S3) to ON and check that lamp(s) illuminate and that the light rotates giving 70 ±30 flashes per minute.

**9-319. TROUBLESHOOTING - ANTICOLLISION LIGHT SYSTEM.**

Refer to paragraph F-9 in Appendix F for wiring diagrams. Use Table 9-18 and perform checks as necessary to isolate trouble. In the following table, tripped circuit breakers are omitted from indications of trouble. Such trouble is usually easily detected and corrected. Broken wiring is always a probable cause of circuit malfunction or failure and has not been included.

**NOTE**

**Before you use this table, be sure you have performed all normal operational checks. If you have a malfunction which is not listed in this table, notify the next higher level of maintenance.**

**Table 9-18. Troubleshooting Anticollision Light System**

CONDITION

TEST OR INSPECTION

**CORRECTIVE ACTION**

1. Anticollision light (8DS5) fails to flash.

STEP 1. Set ANTI-COLL LT switch (8S3) to ON. Check for 28 Vdc NON-ESNTL BUS voltage on terminals 1 and 2 of switch (8S3).

**Replace switch if voltage is not present on terminal 1. Replace bulb or light, as needed, if voltage is present (paragraph 9-16),**

2. Anticollision light (8DS5) fails to rotate.

STEP 1. Set ANTI-COLL LT switch (8S3) to ON. Check for 28 Vdc NON-ESNTL BUS voltage on terminals A and B of connector (8DS5P1 ).

If voltage check indicates motor is defective, replace motor (paragraph 9-16).

**9-320. ANTICOLLISION LIGHT.**

**9-321. CLEANING - ANTICOLLISION LIGHT,**

- a. Remove moisture and loose dirt with a clean, soft cloth,



**Cleaning solvent is flammable and toxic. Provide adequate ventilation. Avoid prolonged breathing of solvent vapors and contact with skin or eyes.**

- b. Remove grease, fungus, and ground-in dirt with a clean, tint-free cloth dampened with dry cleaning solvent (C112),

- c. Remove dirt from electrical connectors with a bristle brush,

**9-322. INSPECTION - ANTICOLLISION LIGHT.**

- a. Inspect light for broken cover, lens or open lamp filament.

- b. Inspect light for damaged case, or broken connector pins.

- c. Inspect motor for damage and proper operation.

**9-323. REMOVAL - ANTICOLLISION LIGHT.**

- a. Be sure that all electrical power is OFF.



b. Remove mounting screws around base of light, lift light up, and disconnect electrical connector.

**9-324. REPAIR - ANTICOLLISION LIGHT.**

a. Loosen screw securing lens cover retaining ring, lift lens from light base. Install and secure lamp, lens or cover in reverse order of removal procedure.

b. Replace complete unit if inspection requirements are not met. Return to depot for repair.

**9-325. INSTALLATION - ANTICOLLISION LIGHT.**

a. Connect electrical connector to light and secure with lockwire (C136).

b. Place light in recess and install mounting screws and ground strap.

c. Check light for proper operation.

**9-326. SEARCHLIGHT SYSTEM.**

**9-327. DESCRIPTION - SEARCHLIGHT SYSTEM.**

The searchlight (8DS6) is located under the gunner section and the circuit consists of one controllable light, two circuit breakers (8CB3 and 8CB4) located in the dc circuit breaker panel (2A1), and two switches (8S4 and 8S5) located on the pilot collective stick (4A2). Switch (8S4) controls extend, retract, rotate left, and rotate right motion. Switch (8S5) controls OFF, ON, and STOW functions.

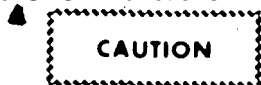

**Do not operate searchlight in areas of combustible material, such as tall grass, etc.**

**9-328. FUNCTIONAL TEST - SEARCHLIGHT SYSTEM.**

a. Close SRCH LT PWR and SRCH LT CONT circuit breakers. Position SRCH LT switch (8S5) to ON and check that searchlight illuminates. Return switch (8S5) to OFF.

b. Position four-way SRCH LT switch (8S4) to EXT (fwd position). Check that light extends and is stopped by extend limit switch at approximately 120 degrees extension.

c. Position, switch (8S4) to RETR (aft position). Check that light retracts.

d. With light partially extended, position switch (8S4) to L and check that light rotates to the left.

e. Position switch (8S4) to R and check that light rotates to the right.

f. With light extended and rotated, position switch (8S5) to STOW. Check that light retracts and is stopped by the retract limit switch and then rotates to its level stowed position and stops,

**9-329. TROUBLESHOOTING - SEARCHLIGHT SYSTEM.**

Refer to paragraph F-9 in Appendix F for wiring diagram. Use Table 9-19 and perform checks as necessary to isolate trouble. In the following table, tripped circuit breakers are omitted from indications of trouble. Such trouble is usually easily detected and corrected. Broken wiring is always a probable cause of circuit malfunction or failure and has not been included.

NOTE

Before you use this table, be sure you have performed all normal operational checks. If you have a malfunction which is not listed in this table, notify the next higher level of maintenance.

Table 9-19. Troubleshooting Searchlight System

---

CONDITION
TEST OR INSPECTION
CORRECTIVE ACTION
1. Searchlight (8DS6) inoperative.
STEP 1. Set SRCH LT switch (8S5) to ON. Check for 28 Vdc NON ESNTL BUS voltage on terminals 1 and 2 of switch (8S5).
<b>Replace switch (8S5) if voltage is not present on terminal 1 (paragraph 9-16),</b>
2. Light dim, constantly or intermittently.
STEP 1. Check for proper grounding.
<b>Remove light, clean ground and replace light (paragraph 9-330).</b>
3. Light out.
STEP 1. Remove lamp and check for open filament and corrosion.
<b>Replace lamp unit or clean terminals as needed (paragrpah 9-330).</b>

---

**9-330. SEARCHLIGHT.**

**9-3310 CLEANING - SEARCHLIGHT.**

a. Remove moisture and loose dirt with a clean, soft cloth.

b. Remove grease, fungus, and ground-in dirt with a clean, lint-free cloth dampened with dry cleaning solvent (C112).

c. Remove dirt from electrical connectors with a bristle brush.



**Cleaning solvent is flammable and toxic. Provide adequate ventilation. Avoid prolonged breathing of solvent vapors and contact with skin or eyes.**

**9-332. INSPECTION - SEARCHLIGHT.**

a. Check light for defective or broken sealed beam unit and for cracked or broken IR lens.

b. Check for loose connections, and damaged or defective component parts (terminal strips, limit switches, drive motors, relays, etc.)

**9-333. REMOVAL — SEARCHLIGHT.**

- a. Be sure all electrical power is OFF.
- b. Remove attaching screws from light assembly mounting plate; lower light and plate.
- c. Remove light mounting screws.
- d. Remove terminal cover, disconnect and protect wires.
- e. Remove light assembly.

**9-334. REPAIR — SEARCHLIGHT.**

- a. Accomplish replacement of sealed beam lamp as follows. Remove three screws from lamp retainer ring and/or IR cover, remove ring, if installed, IR cover, and gasket, lift lamp and disconnect wiring.

**NOTE**

Observe position of lamp before removal and install new unit in same position using reverse order of removal procedure.

- b. Replace complete unit if inspection items are not met. Return unit to depot for repair.

**9-335. INSTALLATION — SEARCHLIGHT.**

- a. Connect wires and install terminal cover and clamp.
- b. Position light on mounting plate; secure with mounting screws.
- c. Position plate and light assembly on fuselage and secure with mounting screws.

- d. Check light for proper operation.

**9-336. TRANSMISSION OIL LEVEL LIGHT.**

**9-337. DESCRIPTION — TRANSMISSION OIL LEVEL LIGHT.**

The transmission oil level light (8DS16) is located inside the transmission cowling on the right side of the helicopter. The light is used to illuminate the transmission sump area so that the transmission oil level sight gages will be visible when viewing through the transmission oil level sight glass. The light is powered from the battery system through a 5 ampere XMSN OIL LEVEL LT circuit breaker (8CB11) located in the aft electrical compartment. Pressing the XMSN OIL LEVEL LT switch (8S8), located beside the sight glass, illuminates the light. Refer to paragraphs 9-18 through 9-29 for maintenance procedures.

**9-338. FUNCTIONAL TEST — TRANSMISSION OIL LEVEL LIGHT**

- a. Disconnect external power if applied. Connect battery.

- a.1. Close XMSN OIL LEVEL LT circuit breaker.

- b. Press pushbutton switch (8S8). Check operation of the light through the sight glass in the right hand transmission cowling.

**9-339. TROUBLESHOOTING — TRANSMISSION OIL LEVEL LIGHT.**

Use Table 9-20 and perform checks as necessary to isolate trouble. In the following table, tripped circuit breakers are omitted from indications of trouble. Such trouble is usually easily detected and corrected. Broken wiring is always a probable cause of circuit malfunction or failure and has not been included.

**NOTE**

Before you use this table, be sure you have performed all normal operational checks. If you have a malfunction which is not listed in this table, notify the next higher level of maintenance.

**Table 9-20 Troubleshooting Transmission Oil Level Light**

---

**CONDITION**

**TEST OR INSPECTION**

**CORRECTIVE ACTION**

1. Transmission oil level light (8DS16) fails to illuminate.

**STEP 1. Check for voltage at circuit breaker (8CB11) XMSN OIL LEVEL LT.**

If check indicates circuit breaker (8CB11) is defective, replace it (paragraph 9-23).

**STEP 2. Set XMSN OIL LEVEL LT SW (8S8) to the ON position. Check for bus voltage on terminals 1 and 2 of switch (8S8).**

Replace switch (8S8) if voltage is not present on terminal 1 (paragraph 9-16).

**STEP 3. Check filament, lamp housing, and ground of XMSN OIL LEVEL LT (8DS16).**

Replace bulb or lamp housing and clean ground as needed (paragraph 9-16).

---

**SECTION VII. MISCELLANEOUS EQUIPMENT**

**9 - 3 4 0 MISCELLANEOUS EQUIPMENT.**

**9 - 3 4 1. DESCRIPTION MISCELLANEOUS EQUIPMENT.**

Miscellaneous equipment includes engine controls and accessories, flight control systems, heating and cooling systems, stability and control augmentation system, and armament systems circuitry.

**9-342. ENGINE CONTROLS AND ACCESSORIES (ELECTRICAL),**

**9-343. DESCRIPTION - ENGINE CONTROLS AND ACCESSORIES (ELECTRICAL).**

Engine controls and accessories include engine de-icing, engine oil bypass valve, fuel valve, fuel boost pumps, governor control, and idle stop solenoid circuitry.

9-344. ENGINE DE-ICE CIRCUITRY,

9-345. DESCRIPTION – ENGINE DE-ICE CIRCUITRY.

The engine de-ice system is comprised of an engine hot air de-icing valve, located on the engine, pilot and gunner ENG DE-ICE switches (1S34) and (1S31), and is protected by a 5 ampere ENG DE-ICE circuit breaker (1CB8). The system is energized from the 28 Vdc essential bus. The valve may be controlled by either the gunner ENG DE-ICE switch (1S31), located on the gunner miscellaneous panel, or the pilot ENG DE-ICE switch (1S34), located on the pilot engine control panel. The de-ice system is normally energized to prevent the de-icing system from activating. If either switch (1S31) or (1S34) is placed to the DE-ICE position, the circuit is broken and the de-icing system is activated. (Refer to paragraphs 9-18 through 9-29 and TM 55-2840-229-24 for maintenance procedures.)

9-346. FUNCTIONAL TEST – ENGINE DE-ICE CIRCUITRY.

a. Open all circuit breakers and return all switches to their normal positions.

b. Note that both switches (1S31) and (1S34) are in the OFF position, then close ENG DE-ICE circuit breaker. Check that de-icing hot air solenoid valve has actuated.

c. Place (1S31) to DE-ICE. Check that hot air solenoid valve is not energized.

d. Return switch (1S31) to OFF position. Check that hot air solenoid valve is again energized.

e. Repeat steps c. and d., except substitute switch (1S34) for switch (1S31).

9-347. TROUBLESHOOTING – ENGINE DE-ICE CIRCUITRY.

Refer to paragraph F-9 in Appendix F for wiring diagram. Use Table 9-21 and perform checks as necessary to isolate trouble. In the following table, tripped circuit breakers are omitted from indications of trouble. Such trouble is usually easily detected and corrected. Broken wiring is always a probable cause of circuit malfunction or failure and has not been included.

NOTE

Before you use this table, be sure you have performed all normal operational checks. If you have a malfunction which is not listed in this table, notify the next higher level of maintenance.

Table 9-21. Troubleshooting Engine De-Ice Circuitry

CONDITION

TEST OR INSPECTION

CORRECTIVE ACTION

1. De-icing hot air solenoid valve fails to de-energize when either ENG DE-ICE switch (1S31) or (1S34) is placed to DE-ICE position.

STEP 1. Determine that DE-ICE switches (1S31 and/or 1S34) are functional.

If DE-ICE switches (1S31 and/or 1S34) are not functioning properly, replace as required (paragraph 9-16).

Table 9-21. Troubleshooting Engine De-Ice Circuitry (Cont)

CONDITION
TEST OR INSPECTION
CORRECTIVE ACTION
<p>STEP 2. Defective de-icing hot air solenoid valve.</p> <p>Replace adenoid valve In accordance with TM 55-2840-229-24.</p>

**9-348. ENGINE OIL BYPASS VALVE CIRCUITRY.**

(2) Place ENG OIL BYP switch to AUTO. Check that position indicator on oil bypass valve rotates clockwise (bypass condition.)

**9-349. DESCRIPTION – ENGINE OIL BYPASS VALVE CIRCUITRY.**

d Perform following procedure for oil in tank condition.

The engine oil bypass valve is energized from the 28 Vdc essential bus and protected by the FUEL/OIL VALVE circuit breaker (1CB4). An oil bypass valve (1B1), located on the lower firewall forward left side, provides a means of by passing the flow of engine oil around the oil cooler in case of damage resulting in a leak in the cooler. The valve is electrically actuated and is included in a circuit with ENG OIL BYP switch (1S16) (manually operated), engine oil float switch (1S15), and oil bypass relay (1K6). Switch (1S16) is located on the pilot engine control panel (1A1). Switch (1S15) is located in the oil tank, and relay (1K6) is located beneath the upper firewall. (Refer to paragraphs 8-18 through 9-29 and TM 55-2840-228-24 for maintenance procedures.)

(1) Connect temporary shod circuit between terminal 1 and 2 on (1T85). Check that position indicator on oil bypass valve is rotated to its clockwise extreme (bypass condition).

(2) Place ENG OIL BYP switch to OFF. Check that position indicator on oil bypass valve rotates to its full counterclockwise extreme (normal condition).

(3) Remove temporary shod circuit. Oil bypass valve should not move.

(4) Place ENG OIL BYP switch to AUTO. Oil bypass valve should not move.

**9-350. FUNCTIONAL TEST – ENGINE OIL BYPASS VALVE CIRCUIT.**

a Close FUEL/OIL VALVE circuit breaker (1CB4).

b. Place ENG OIL BYP switch to AUTO.

c. Perform following procedure for empty tank condition.

(1) Place ENG OIL BYP switch to OFF. Check that position indicator on oil bypass valve rotates counterclockwise (normal condition).

**9-351. TROUBLESHOOTING — ENGINE OIL BYPASS VALVE CIRCUITRY.**

Refer to paragraph F-9 in Appendix F for wiring diagram. Use Table 9-22 and perform check as necessary to isolate trouble. In the following table, tripped circuit breakers are omitted from indications of trouble. Such trouble is usually easily detected and corrected. Broken wiring is always a probable cause of circuit malfunction or failure and not been included.

## NOTE

**Before you use this table, be sure you have performed all normal operational checks. If you have a malfunction which is not listed in this table, notify the next higher level of maintenance.**

**Table 9-22. Troubleshooting Engine Oil Bypass Valve Circuitry**

## CONDITION

## TEST OR INSPECTION

**CORRECTIVE ACTION**

1. Oil bypass valve (1B1) fails to operate with ENG OIL BYP switch (1S16) in AUTO position and oil float switch (1S15) closed (oil tank low).

STEP 1. Determine that ENG OIL BYP switch (1S16) is functional.

**If ENG OIL BYP switch (1S16) is not functioning properly, replace as required (paragraph 9-1 6).**

STEP 2. Determine that oil float switch (1S15) is functional.

**If oil float switch (1S15) is not functioning properly, replace as required (paragraph 9-1 6).**

STEP 3. Check that OIL BYPASS relay (1K6) is functional.

**Replace oil bypass relay (1K6) as required (paragraph 9-16).**

STEP 4. Check that oil bypass valve (1B1) is functional

**Replace oil bypass valve (1B1) in accordance with paragraph 9-16 and TM 55-2840-229-24.**

**9-352. FUEL VALVE CIRCUITRY.****9-353. DESCRIPTION - FUEL VALVE CIRCUITRY.**

An electrically operated fuel shut-off valve (1B4) located on the top of the aft fuel cell, provides a means of shutting off fuel to the engine. This valve is energized from the 28 Vdc essential bus and protected by the FUEL/OIL VALVE circuit breaker (1CB4). The FUEL switch (1S33), on the pilot engine control panel (1 AI ), controls the operation of the valve. Refer to paragraphs 9-18 through 9-29 and TM 55-2840-229-24 for maintenance procedures.

**9-354. FUNCTIONAL TEST - FUEL VALVE CIRCUITRY.**

**a.** Close FUEL/OIL VALVE circuit breaker. Position FUEL switch (1S33) to FUEL. Check that fuel valve opens.

**b.** Position FUEL switch (1S33) to OFF and check that fuel valve closes.

**9-355. TROUBLESHOOTING - FUEL VALVE CIRCUITRY.**

Refer to paragraph F-9 in Appendix F for wiring diagram. Use Table 9-23 and perform checks as

necessary to isolate trouble. In the following table, tripped circuit breakers are omitted from indications of trouble. Such trouble is usually easily detected and

corrected. Broken wiring is always a probable cause of circuit malfunction or failure and has not been included.

**NOTE**

**Before you use this table, be sure you have performed all normal operational checks, If you have a malfunction which is not listed in this table, notify the next higher level of maintenance,**

**Table 9-23 Troubleshooting Fuel Valve Circuitry**

---

CONDITION
TEST OR INSPECTION
CORRECTIVE ACTION
<p>1. Fuel shut-off valve (1B4) fails to open when FUEL switch (1S33) is placed to FUEL.</p> <p>STEP 1. Check for 28 Vdc essential bus power on terminals 4 and 5 of fuel switch (1S33).</p> <p style="padding-left: 40px;"><b>Replace fuel switch (1S33) if 28 Vdc is not on terminal 4 (paragraph 9-1 6).</b></p> <p>STEP 2. Determine that fuel shut-off valve (1B4) is functional.</p> <p style="padding-left: 40px;"><b>If fuel shut-off valve (1 64) is not functioning properly, replace valve in accordance with paragraph 9-16 and TM 55-2840-229-24.</b></p>

---

**9-356. FUEL BOOST PUMPS CIRCUITRY.**

**9-357. DESCRIPTION - FUEL BOOST PUMPS CIRCUITRY,**

Two electrically operated fuel boost pumps, one each in the forward and aft fuel cell, are accessible from the bottom of the cell. Both pumps are connected to a common fuel line. The forward fuel boost pump (1B5) is energized from the 28 Vdc essential bus and protected by the FUEL BOOST FWD circuit breaker (1CB9), located in the dc circuit breaker panel (2A1). The aft fuel boost pump (1B6) is energized from the 28 Vdc non-essential bus and protected by the FUEL BOOST AFT circuit breaker (1CB12) in the dc circuit breaker panel. Both pumps are controlled by the FUEL switch (1S33) located on the pilot engine control

panel (1A1). Refer to paragraphs 9-18 through 9-29 and chapter 10 for maintenance procedures.

**9-358. FUNCTIONAL TEST- FUEL BOOST PUMPS CIRCUITRY.**

a. Open FUEL BOOST AFT circuit breaker and close FUEL BOOST FWD circuit breaker. Position FUEL switch (1S33) to ON. Check that the forward fuel pump is running.

b. Open FUEL BOOST FWD circuit breaker. Close FUEL BOOST AFT circuit breaker. Position FUEL switch (1S33) to ON. Check that the aft fuel pump is running.

c. Open FUEL BOOST AFT circuit breaker.



**9-359. TROUBLESHOOTING - FUEL BOOST PUMPS CIRCUITRY,**

Refer to paragraph F-9 in Appendix F for wiring diagram. Use Table 9-24 and perform checks as necessary to isolate trouble. In the following table,

tripped circuit breakers are omitted from indications of trouble. Such trouble is usually easily detected and corrected. Broken wiring is always a probable cause of circuit malfunction or failure and has not been included.

**NOTE**

**Before you use this table, be sure you have performed all normal operational checks. If you have a malfunction which is not listed in this table, notify the next higher level of maintenance.**

**Table 9-24. Troubleshooting Fuel Boost Pumps Circuitry**

---

CONDITION
TEST OR INSPECTION
CORRECTIVE ACTION
1. Either pump (1B5) or (1B6) fails to operate when FUEL switch (1S33) is placed to FUEL.
STEP 1. Determine if fuel switch (1S33) is functional.
<b>If fuel switch (1S33) is not functioning properly, replace as required (paragraph 9-16)</b>
STEP 2. Determine that fuel boost pumps (1B5 and/or 1B6) are functioning properly.
<b>If fuel boost pumps (1B5 and/or 1B6) are not functioning properly, replace as required (paragraph 10-25).</b>

---

**9-360. GOVERNOR CONTROL SYSTEM CIRCUITRY.**

**9-361. DESCRIPTION - GOVERNOR CONTROL CIRCUITRY.**

The governor control system is comprised primarily of an engine fuel control solenoid valve located on the engine, and a motor driven governor rpm actuator (1B3), also located on the engine. The 28 Vdc power to the system is served and protected by a 5 ampere GOV CONT circuit breaker (1CB5), which is located in pilot dc circuit breaker panel (2A1). The actuator is energized either by RPM switch (1S35) located on pilot collective stick, or by RPM switch (1S29), located

in the gunner miscellaneous control panel. The solenoid valve is energized by GOV switch (1S32) located on pilot engine control panel, or by GOV switch (1S28) located on gunner miscellaneous control panel. Refer to paragraphs 9-18 through 9-29 and TM 55-2840-229-24 for maintenance procedures.

**9-362. FUNCTIONAL TEST - GOVERNOR CONTROL CIRCUITRY.**

a. Close GOV CONT circuit breaker (1CB5). Position GOV switch (1S32) on pilot engine control panel, and (1S28) on gunner miscellaneous control panel to AUTO. Check for audible indication that the

fuel control solenoid valve on the engine is energized in the automatic position.

b. Place GOV switch (1S32) on pilot engine control panel to **P**EMER **E** **M** EMERG. Check that the fuel control solenoid valve is energized in the emergency position and that **P** GOV EMER **E** **M** GOV EMERG indicators on the pilot and gunner caution panels are illuminated.

c. Return pilot GOV switch (1S32) to AUTO position. Check that GOV EMER **E** **M** GOV EMERG indicators on both caution panels are extinguished.

d. Place GOV switch (1S28) on gunner miscellaneous control panel to **P**EMER **E** **M** EMERG. Check for audible indication that the fuel control solenoid valve is energized in the emergency position. Check that **P**GOV EMER **E** **M** GOV EMERG indicators on the caution panels are illuminated.

e. Return GOV switch (1S28) to AUTO. Check that **P**GOV EMER **E** **M** GOV EMERG indicators are extinguished.

f. Position RPM switch (1S35) on pilot collective stick, to INCR and check that governor rpm actuator on the engine retracts.

g. Position RPM switch (1S35) to DECR and check that actuator extends.

h. Repeat steps e. and f. using RPM switch (1S29) on gunner miscellaneous control panel (1A2).

### 9-363. TROUBLESHOOTING - GOVERNOR CONTROL CIRCUITRY.

Refer to paragraph F-9 in Appendix F for wiring diagram. Use Table 9-25 and perform checks as necessary to isolate trouble. In the following table, tripped circuit breakers are omitted from indications of trouble. Such trouble is usually easily detected and corrected. Broken wiring is always a probable cause of circuit malfunction or failure and has not been included.

#### NOTE

**Before you use this table, be sure you have performed all normal operational checks, if you have a malfunction which is not listed in this table, notify the next higher level of maintenance.**

**Table 9-25. Troubleshooting Governor Control Circuitry**

CONDITION

TEST OR INSPECTION

#### CORRECTIVE ACTION

1. Governor actuator fails to respond when either RPM switch (1S29) or (1S35) is placed to INCR or DECR position.

STEP 1. Determine that RPM switches (1S29 and/or 1S35) are functioning properly.

**Replace RPM switches (1S29 and/or 1S35) as required (paragraph 9-1 6).**

STEP 2. Check for defective governor actuator.

**Replace governor actuator, if defective, in accordance with TM 55-2840-229-24.**

**Table 9-25. Troubleshooting Governor Control Circuitry (Cont)**

CONDITION

TEST OR INSPECTION

**CORRECTIVE ACTION**

2. Actuator operates in reverse.

STEP 1. Switch (1S29 and/or 1S35) or actuator wiring reversed.

**Check governor control system wiring diagram and correct wiring as necessary.**

3. Fuel control solenoid valve fails to operate when either GOV switch (1S28) or (1S32) is actuated.

STEP 1. Determine that governor switches (1S28 and 1S32) are functioning properly.

**Replace governor switches (1S28 and/or 1S32) as required (paragraph 9-1 6).**

STEP 2. Check for defective fuel control solenoid valve.

**Replace fuel control solenoid valve, if defective, in accordance with TM 55-2840-229-24.**

4. Solenoid valve operates in reverse.

STEP 1. Switches (1S28 and/or 1S32) or solenoid valve wiring reversed.

**Check governor control system wiring diagram and correct wiring as necessary.**

**9-364. IDLE STOP SOLENOID SYSTEM CIRCUITRY.**

collective stick and check that the solenoid retracts when power is applied.

**9-365. DESCRIPTION - IDLE STOP SOLENOID SYSTEM CIRCUITRY.**

The idle stop system includes a 5 ampere IDLE STOP SOL circuit breaker (1CB3) on the dc circuit breaker panel (2A1), switches (1S37) and (1S30), located on pilot collective (4A2) and gunner miscellaneous panel (1A2) respectively, and an idle stop solenoid (1L5) located in oil cooler compartment. Solenoid (1L5) is energized from 28 Vdc essential bus when circuit breaker (1CB3) and either (1S37) or(1S30) is pressed. Refer to paragraph 9-18 through 9-29 and TM 55-2840-229-24 for maintenance procedures.

**b.** Release switch (1S37). Place IDLE STOP RELEASE switch (1S30) on gunner miscellaneous control panel to the IDLE STOP RELEASE position. Check that idle stop solenoid (1L5) retracts and remains retracted. Place switch (1S30) to OFF position. Check that idle stop solenoid (1L5) is released.

**9-366. FUNCTIONAL TEST - IDLE STOP SOLENOID SYSTEM CIRCUITRY.**

**a.** Close IDLE STOP SOL circuit breaker (1CB3). Actuate the idle stop release switch (1S37) on pilot

**9-367. TROUBLESHOOTING - IDLE STOP SOLENOID SYSTEM CIRCUITRY.**

Refer to paragraph F-9 in Appendix F for wiring diagram. Use Table 9-26 and perform checks as necessary to isolate trouble. In the following table, tripped circuit breakers are omitted from indications of trouble. Such trouble is usually easily detected and corrected. Broken wiring is always a probable cause of circuit malfunction or failure and has not been included.

NOTE

Before you use this table, be sure you have performed all normal operational checks. If you have a malfunction which is not listed in this table, notify the next higher level of maintenance.

Table 9-26. Troubleshooting Idle Stop Solenoid System Circuitry

---

CONDITION

TEST OR INSPECTION

**CORRECTIVE ACTION**

1. Engine idle Stop does not retract when IDLE STOP RELEASE switches (1S30) and/or (1S37) are actuated.

STEP 1. Determine that idle stop switches (1S30 and/or 1S37) are functional.

**If idle stop switches (1S30 and/or 1S37) are not functioning properly, replace as required (paragraph 9-16).**

STEP 2. Check that idle stop solenoid (1L5) is functional.

**If idle stop solenoid (1L5) is not functioning properly, replace solenoid in accordance with TM 55-2840-229-24.**

2. Engine idle stop solenoid (1L5) does not extend after IDLE STOP RELEASE switch is released from depressed position.

STEP 1. Repeat STEP 1 above.

STEP 2. Repeat STEP 2 above.

---

Paragraphs 9-367.1 through 9-367.4 have been deleted.  
Page 9-110.1 and Table 9-26.1 have been deleted



**9-368. FLIGHT CONTROL SYSTEMS (ELECTRICAL).**

**9-369. DESCRIPTION - FLIGHT CONTROL SYSTEMS (ELECTRICAL).**

Flight control systems include the force trim system and hydraulic control system circuitry.

**9-370, FORCE TRIM SYSTEM CIRCUITRY.**

**9-371. DESCRIPTION - FORCE TRIM SYSTEM CIRCUITRY.**

The force trim system consists of an anti-torque force trim magnetic brake (9L1), a fore and aft force trim

magnetic brake (9L3), and lateral force trim magnetic brake (9L2). Magnetic brakes (9L1, (9L3), and (9L2) are wired in parallel and energized and protected by a 5 ampere FORCE TRIM circuit breaker (9CB1), which is located in the dc circuit breaker panel (2A1). The FORCE TRIM momentary switch (9S1) located on pilot cyclic stick (4A3), FORCE TRIM selector switch (9S2), located on pilot engine control panel (1A1), FORCE TRIM switch (9S3), located on gunner cyclic stick (5A2), are all series wired. The entire system serves to return pilot and gunner cyclic sticks to desired initial position when switch (9S2) is set to ON position. Switch (9S1 ) or (9S3) may be triggered to de-energize brakes and eliminate centering force. With switch (9S2) set to OFF position, automatic trim force is de-energized.

**9-372. FUNCTIONAL TEST — FORCE TRIM SYSTEM CIRCUITRY.**

a. Apply external hydraulic power.

a.1 Close FORCE TRIM circuit breaker (9CB1). Position force trim switch (9S2) on pilot engine control panel to FORCE TRIM. Check the cyclic stick and pedals for centering force.

b. Depress force trim switch (9S1) on the pilot cyclic stick. Check that the three magnetic brakes de-energize and that there is no centering force in the cyclic stick and pedals.

c. Repeat step b. using FORCE TRIM switch (9S3) on the gunner cyclic stick

d. Remove external hydraulic power.

**9-373. TROUBLESHOOTING — FORCE TRIM SYSTEM CIRCUITRY.**

Refer to paragraph F-9 in Appendix F for wiring diagram. Use Table 9-27 and perform checks as necessary to isolate trouble. In the following table, tripped circuit breakers are omitted from indications of trouble. Such trouble is usually easily detected and corrected. Broken wiring is always a probable cause of circuit malfunction or failure and has not been included.

**NOTE**

Before you use this table, be sure you have performed all normal operational checks. If you have a malfunction which is not listed in this table, notify the next higher level of maintenance.

**Table 9-27. Troubleshooting Force Trim System Circuitry**

<b>CONDITION</b>	
<b>TEST OR INSPECTION</b>	<b>Corrective ACTION</b>
1. All magneticbrakes (9L1), (9L2), and (9L3) fail to energize with FORCE TRIM switch (9S2) in FORCE TRIM position.	<p><b>STEP 1.</b> Determine that force trim switches (9S1, 9S2, and 9S3) are functioning properly.</p> <p>If force trim switches (9S1, 9S2, and 9S3) are not functioning properly, replace as required (paragraph 9-16).</p>
2. Any magnetic brake (9L1), (9L2), or (9L3) fails to energize with FORCE TRIM switch (9S2) in FORCE TRIM position.	<p><b>STEP 1.</b> Determine that magnetic brakes (9L1, 9L2, and 9L3) are functioning properly.</p> <p>If magnetic brakes (9L1, 9L2, and 9L3) are not functioning properly, replace as required (paragraph 9-16).</p>

9-374. HYDRAULIC CONTROL SYSTEM CIRCUITRY.

9-375. DESCRIPTION — HYDRAULIC CONTROL SYSTEM CIRCUITRY.

The hydraulic control system is comprised primarily of two hydraulic solenoid valves, system No. 1 (1L1) and system No. 2 (1L2), mounted on the bulkhead left and right, forward of the transmission. Each valve function may be tested by the HYDR TEST switch (1S17) located on the pilot engine control panel (1A1). Each solenoid valve is normally de-energized. Emergency hydraulic solenoid valves (1L3 and 1L4) located in the pylon section, serve to supply emergency hydraulic pressure from the emergency hydraulic pump. The valves are normally de-energized to prevent hydraulic fluid flow and may be energized to permit fluid flow by setting EMER HYDR switches (1S22 or 1S23) on the pilot miscellaneous control panel (22A1) or gunner instrument panel (5A1) to EMER HYDR. The system is supplied from the 28 Vdc essential bus and protected by a 5 ampere HYD CONT circuit breaker (1CB1) which is located on the dc circuit breaker panel (2A1). The EMER HYDR PUMP OVLD SW (1S24) located in the aft electrical compartment and the EMER HYDR pump circuit breaker (1CB2) located in the dc circuit breaker panel (2A1) protect the EMER HYDR system.

9-376. FUNCTIONAL TEST — HYDRAULIC CONTROL SYSTEM CIRCUITRY.

a. Perform test of hydraulic solenoid as follows: Close HYDR CONT and CAUT LT circuit breakers. Check that **P** NO. 1 HYDR PRESS and NO. 2 HYDR PRESS **E** **M** #1 HYD PRESS and #2 HYD PRESS caution lights on pilot caution panel (8A2) and **P** HYDR PRESS #1 and HYDR PRESS #2 **E** **M** #1 HYD PRESS and #2 HYD PRESS caution lights on gunner caution panel (8A3) are illuminated.

(1) Try to operate cyclic, collective, and directional controls. Note that controls take extreme force and are very difficult to move.

(2) Apply external hydraulic pressure to hydraulic system NO. 1. Check that **P** NO. 1 HYDR PRESS **E** **M** #1 HYD PRESS caution light on pilot and **P** HYDR PRESS #1 **E** **M** #1 HYD PRESS caution light on gunner caution panels are extinguished.

(3) Repeat step (2) for hydraulic system NO. 2.

(4) Position HYD TEST switch (1S17) on pilot engine control panel to SYS 1. Check that hydraulic system NO. 2 solenoid (1L2) actuates. Check that **P** NO. 2 HYDR PRESS **E** **M** #2 HYD PRESS caution light on pilot and **P** HYDR PRESS NO. 2 **E** **M** #2 HYD PRESS caution light on gunner caution panels illuminate.

(5) Position HYD TEST switch to SYS. 2. Check that hydraulic system NO. 1 solenoid (1L1) actuates. Check that **P** NO. 1 HYDR PRESS, **E** **M** #1 HYD PRESS caution light on pilot and **P** HYDR PRESS #1 **E** **M** #1 HYD PRESS caution light on gunner caution panels illuminate.

(6) Repeat step (1) with external hydraulic power applied. Check that all controls take much less force to operate.

(7) Open HYDR CONT circuit breakers.

(8) Remove external hydraulic power. ■

b. Perform test of emergency hydraulic system as follows:

(1) Close EMER HYDR PUMP circuit breaker. Place EMER HYDR PUMP switch (1S22) on pilot miscellaneous panel (22A1) to BORESIGHT position. Check that emergency hydraulic pump (1B2) operates.

(2) Place EMER HYDR PUMP switch to OFF position. Check that emergency hydraulic pump stops operating.

(3) Place EMER HYDR PUMP switch to EMER HYDR PUMP position. Check that emergency hydraulic pump operates.

(4) Place EMER HYDR PUMP switch to OFF position. Check that emergency hydraulic pump stops operating.

(5) Repeat steps (1) through (4) using EMER HYDR PUMP switch (1S23) on gunner instrument panel in lieu of EMER HYDR PUMP switch (1S22).

(6) Close HYDR CONT circuit breaker.

m Repeat steps (1) through (5). Note that EMER HYDR SOLV (1L3) and (1L4) actuate and emergency hydraulic pump operates.

(8) Open EMER HYDR PUMP circuit breaker.

(9) Remove external hydraulic power. ■



## 9-377. TROUBLESHOOTING HYDRAULIC CONTROL SYSTEM CIRCUITRY.

Refer to paragraph F-9 Appendix F for wiring diagram.  
Use Table 9-28 and perform checks as necessary to

isolate trouble. In the following table tripped circuit breakers are omitted from indications of trouble. Such trouble is usually easily detected and corrected. Broken wiring is always a probable cause of circuit malfunction or failure and has not been included.

### NOTE

**Before you use this table, be sure you have performed all normal operational checks. If you have a malfunction which is not listed in this table, notify the next higher level of maintenance.**

**Table 9-28. Troubleshooting Hydraulic Control System Circuitry**

---

CONDITION
TEST OR INSPECTION
CORRECTIVE ACTION
1. Either solenoid (1L1 ) or (1L2) fails to actuate when selected by HYD TEST Switch.
STEP 1. Check that HYD TEST switch (1S17) is functioning properly.
<b>If HYD TEST switch (1S17) is not functioning properly, replace (paragraph 9-16).</b>
STEP 2. Check that solenoids (1L1 and 1L2) are functioning properly.
<b>If solenoids (1L1 and/or 1L2) are not functioning properly, replace as required (paragraph 9-1 6).</b>
2. Emergency solenoid (1L3 and 1L4) de-energized with EMER HYDR Switch (1S22) and (1S23) in EMER HYDR PUMP position.
STEP 1. Check that EMER HYDR pump switches (1S22 and 1S23) are functioning properly.
<b>If EMER HYDR pump switches (1S22 and/or 1S23) are not functioning properly, replace as required (paragraph 9-1 6).</b>
STEP 2. Check that EMERGENCY Solenoids (1L3 and 1L4) are functioning properly.
<b>If EMERGENCY Solenoids (1L3 and/or 1L4) are not functioning properly, replace as required (paragraph 9-16).</b>

---

### 9-378. HEATING AND COOLING SYSTEMS CIRCUITRY.

### 9-379. DESCRIPTION - HEATING AND COOLING SYSTEM CIRCUITRY.

The heating and cooling systems include the environmental control system (ECS), pitot heating system, TOW blower cooling system, and radio blower cooling system.

### 9-380. ENVIRONMENTAL CONTROL SYSTEM CIRCUITRY.

### 9-381. DESCRIPTION ENVIRONMENTAL CONTROL SYSTEM CIRCUITRY.

The environmental control system (ECS) heats, cools, and removes moisture from the air supplied to the crew compartment. It is composed of the environmental control unit (ECU) (1021 ), duct overheat switch (10S3), temperature sensing valve (1 061), bleed air valve (10L1 ), and the heater control relay (1 OK I ). The rain removal system is composed of the rain removal solenoid (10L3), windshield thermal switch (10S7), and rain removal mixing valve (10L4). These systems are energized from the non-essential bus by the ECS CONT circuit breaker (10CB1) and controlled by ECS switch (10S2) and ECS temperature control (10R1 ). Refer to paragraphs 9-18 through 9-29 and 13-2 for maintenance procedures.

### 9-382. FUNCTIONAL TEST - ENVIRONMENTAL CONTROL SYSTEM CIRCUITRY.

- a. Close ECS CONT circuit breaker (10CB1). Position ECS switch (10S2) to RAIN RMV, Check that rain removal solenoid valve (10L3) opens.
- b. Position ECS switch (10S2) to OFF. Check that rain removal solenoid valve closes.
- c. Position ECS switch (10S2) to HTR. Check that bleed air valve (10L1 ) opens.

d. Simulate an overheat condition by grounding terminal X2 (low side) or heater control relay (10K1). Check that heater control relay (10K1) energizes and removes power from the bleed air valve causing it to close.

e. Remove ground from relay (10K1). Check that heater control relay becomes de-energized and that the bleed air valve opens.

f. Position ECS switch (10S2) to OFF. Check that bleed air valve closes.

#### NOTE

**Steps g. through i. require that the helicopter engine be operating.**

g. Start helicopter engine and maintain an engine speed of 100 percent. Position ECS switch (10S2) to HTR. Check that cooling turbine comes up to speed and that airflow is detected at the cabin air inlets.

h. Rotate ECS temperature control (10R1) to extreme COOL position. Check that cabin inlet airflow becomes cool,

i. Rotate ECS temperature control (10R1) to extreme WARM position. Check that cabin inlet airflow becomes warm. Return temperature control to midposition.

j. Stop helicopter engine. Check that the environmental control unit stops operating and that the bleed air valve closes.

### 9-383. TROUBLESHOOTING ENVIRONMENTAL CONTROL SYSTEM CIRCUITRY.

Refer to paragraph F-9 in Appendix F for wiring diagram. Use Table 9-29 and perform checks as necessary to isolate trouble. In the following table, tripped circuit breakers are omitted from indications of trouble. Such trouble is usually easily detected and corrected. Broken wiring is always a probable cause of circuit malfunction or failure and has not been included.

## NOTE

**Before you use this table, be sure you have performed all normal operational checks. If you have a malfunction which is not listed in this table, notify the next higher level of maintenance,**

**Table 9-29. Troubleshooting Environmental Control System Circuitry**

## CONDITION

## TEST OR INSPECTION

**CORRECTIVE ACTION**

1. Bleed air valve (10L1) fails to actuate with environmental control switch (10S2) set to HTR and environmental control set to WARM.

STEP 1. Ensure 28 Vdc non-essential bus voltage is present between pins 3 and 6 of bleed air valve (10L1 ).

**If bleed air valve fails to operate, replace bleed air valve (paragraph 13-4).**

2. Bleed air valve (10L1) fails to energize with ENVIR CONT switch (10S2) set to HTR.

STEP 1. Ensure 28 Vdc non-essential bus voltage is present at connector pin F of dc circuit breaker panel (2A1). Check for 28 Vdc non-essential bus voltage at pin D of pilot LTG/ECS panel (10A1 ).

**If 28 Vdc non-essential bus voltage is not present at Pin D, replace environmental control switch (10S2) (paragraph 9-16).**

STEP 2. Ensure 28 Vdc non-essential bus voltage is present at pin D of connector for panel 10A1. Check for presence of 28 Vdc at B3 of heater control relay (10K1).

**Replace heater control relay (10K1) if 28 Vdc non-essential voltage is not present at B3 (paragraph 9-1 6).**

3. Environmental control unit (10Z1 ) fails to energize with ECS switch (10S2) set to HTR.

STEP 1. Check if duct overheat switch (10S3) is defective.

**Replace duct overheat switch (10S3) if defective (paragraph 9-16).**

4. No air is detected at cabin inlets with ECS switch (10S2) set to HTR and ECS temperature control switch (10R1) positioned to COOL or WARM.

STEP 1. Check environmental control unit (10Z1 ) (paragraph 13-4).

**Replace or repair environmental control unit as necessary (paragraph 9-16).**

5. Environmental control unit temperature control has no effect on cabin inlet air temperature.

STEP 1. Check temperature sensing valve (10B1) (paragraph 13-11).

**If defective, replace temperature sensing valve (10B1) (paragraph 9-16).**

**Table 9-29. Troubleshooting Environmental Control System Circuitry (Cent)**

CONDITION

TEST OR INSPECTION

**CORRECTIVE ACTION**

STEP 2. Check environmental control (10R1).

**If defective, replace environmental control (1 OR 1 ) (paragraph 9-16),**

STEP 3. Check environmental control unit (10Z1) (paragraph 13-5).

**If defective, replace environmental control unit (1021) (paragraph 9-1 6).**

6. Rain removal solenoid (10L3) fails to actuate with environmental control switch set to RAIN RMV.

STEP 1. Check rain removal solenoid (10L3).

**If defective. replace rain removal solenoid (10L3) (paragraph 9-1 6).**

7. Rain removal solenoid (10L4) fails to actuate with environmental control switch set to RAIN RMV.

STEP 1, Check RAIN REM switch (10S7).

**If defective, replace switch (paragraph 9-16).**

STEP 2. Check rain removal solenoid (10L4).

**If defective, replace rain removal solenoid (10L4) (paragraph 9-16).**

**9-384. PITOT HEATING SYSTEM CIRCUITRY.**

**9-385. DESCRIPTION - PITOT HEATING SYSTEM CIRCUITRY,**

The pitot heater system is comprised of the pitot tube heater (10HR1), located on the upper left forward section of the pylon fairing; PITOT/ADS switch (10S1), located on the PLTS LTG/ECS panel and a five ampere PITOT HTR circuit breaker (10CB2). The system is powered from the 28 Vdc non-essential bus. The pitot tube heater (10HR1) prevents the pitot tube from icing over, The heating element is energized manually by the PITOT/ADS switch (10S1). Refer to paragraphs 9-18 through 9-29 and paragraph 8-128 for maintenance procedures.

**9-386. FUNCTIONAL TEST - PITOT HEATING SYSTEM CIRCUITRY.**



Do not leave pitot tube heater energized for a prolonged period of time.

- a. Close PITOT HTR circuit breaker (10CB2).
- b. Position PITOT/ADS switch to PITOT HTR.
- c. Check that pitot heating element is energized and heating. (Refer to TM55-1500-204 -25/1.)
- d. Position PITOT/ADS switch to OFF and open PITOT HTR circuit breaker.

**9-387. TROUBLESHOOTING - PITOT HEATING SYSTEM CIRCUITRY.**

Refer to paragraph F-9 in Appendix F for wiring diagram. Use Table 9-30 and perform checks as necessary to isolate trouble. In the following table,

tripped circuit breakers are omitted from indications of trouble. Such trouble is usually easily detected and corrected. Broken wiring is always a probable cause of circuit malfunction or failure and has not been included.

**NOTE**

**Before you use this table, be sure you have performed all normal operational checks. If you have a malfunction which is not listed in this table, notify the next higher level of maintenance.**

**Table 9-30. Troubleshooting Pitot Heating System Circuitry**

---

CONDITION
TEST OR INSPECTION
CORRECTIVE ACTION
1. Pitot tube heater fails to heat. PITOT/ADS switch (10S1) to HTR.
STEP 1. Check PITOT HTR circuit breaker (10CB2) on DC circuit breaker panel (2A1).
<b>If defective, replace PITOT HTR circuit breaker (10CB2) (paragraph 9-23).</b>
STEP 2. Check PITOT/ADS switch (10S1).
<b>If defective, replace PITOT/ADS switch (10S1) (paragraph 9-16).</b>
STEP 3. Check pitot tube heating element (10HR1).
<b>If defective, replace pitot tube heating element (10HR 1) (paragraph 8-1 2).</b>

---

**9-388. TOW BLOWER COOLING SYSTEM.**

**9-389. DESCRIPTION - TOW BLOWER COOLING SYSTEM .**

The TOW blower cooling system is designed for cooling the electronic/arma merit/avionics equipment mounted on the TOW compartment shelf in the tailboom. The cooling system is comprised of the TOW compartment blower (10B2), TOW compartment blower overload sensor (10S5), TOW compartment blower relay (10K2), TOW compartment overhear switch (10S4, 10CR1), and a

portion of • three-phase to single-phase inverter relay (3K4)/**F M** TMS INTLK relay (22A5A1K6). The system is powered from the non-essential 28 Vdc bus and protected by a one ampere TOW BLO circuit breaker (10CB3). When temperature in the TOW compartment reaches approximately 18.4° Celsius (65°F) TOW compartment overhear switch (10S4) actuates (closes), applying 28 Vdc through 10CR1, through contacts S1 and S2 of TOW blower overload sensor (10S5) to coil XI of TOW blower relay (10K2). The TOW blower relay then applies 28 Vdc through contacts (L1 and L2) of TOW blower overload sensor (10S5) to TOW compartment blower (10B2). Thermal activation of the TOW compartment overhear switch

automatically causes the TOW blower to cycle on and remain on as long as the circuit is energized. Overload protection of the TOW blower is provided by the TOW blower overload sensor (10S5).

**9-390. FUNCTIONAL TEST – TOW BLOWER COOLING SYSTEM.**

a. Close **P** WPN CONT **E** **M** ARMT CONT circuit breaker (10CB2). Place NON-ESS BUS switch (2S2) to STBY (MANUAL) MASTER ARM switch (19S18) to STBY and TCP MODE SELECT switch to STBY TOW. Ensure gunner ELEC PWR-EMER OFF switch (2S4), on gunner miscellaneous control panel, is positioned to ELEC PWR.

b. Perform the following steps for ambient temperature below approximately 18.4° C (65°F).

(1) Close TOW BLO circuit breaker (10CB3). Energize heat gun and direct its hot air a few inches from the TOW overheat sensor switch (10S4), being careful of other components or equipment in this area. After a few seconds, check that TOW blower is operating and is circulating air over the electronic equipment installed in the tailboom.

(2) Reenergize heat gun and let TOW overheat sensor switch cool. After sensor switch cools, TOW blower should shut off.

(3) Deleted.

c. Perform the following steps for ambient temperature above approximately 18.4° Celsius (65°F).

(1) Close TOW BLO circuit breaker (10CB3). Check that TOW blower is energized and is circulating air over the electronic equipment installed in the tailboom.

(2) Open TOW BLO circuit breaker. Check that TOW blower is de-energized and shuts off.

**9-391. TROUBLESHOOTING – TOW BLOWER COOLING SYSTEM.**

Refer to paragraph F-9 in Appendix F for wiring diagram. Use table 9-31 and perform checks as necessary to isolate trouble. In the following table, tripped circuit breakers are omitted from indications of trouble. Such trouble is usually easily detected and corrected. Broken wiring is always a probable cause of circuit malfunction or failure and has not been included.

**NOTE**

Before you use this table, be sure you have performed all normal operational checks. If you have a malfunction which is not listed in this table, notify the next higher level of maintenance.

Table 9-31. Troubleshooting TOW Blower Cooling System

**CONDITION**

**TEST OR INSPECTION**

**CORRECTIVE ACTION**

1. TOW blower(10B2) fails to operate when temperature is above approximately 18.4° Celsius (65° F).

STEP 1. Ensure that 28 Vdc non-essential bus voltage is present at terminal A of connector (10B2P1) for TOW compartment blower (10B2).

Repair connector if voltage is not present at terminal A (paragraph 9-1 6).

STEP 2. Remove blower and inspect for worn brushes.

Replace worn brushes as necessary or replace blower (paragraph 9-1 6).

Table 9-31. Troubleshooting TOW Blower Cooling System (Cont)

## CONDITION

## TEST OR INSPECTION

## CORRECTIVE ACTION

STEP 3. Check TOW compartment blower overload sensor (10S5).

**Replace sensor (10S5) if defective (paragraph 9-16).**

STEP 4. Check TOW COMPARTMENT OVERHEAT SWITCH (10S4).

**Replace switch if defective (paragraph 9-16).**

STEP 5. Check for 28 Vdc non-essential bus voltage through TOW BLO circuit breaker (10CB3) on panel 2A1 .

**Replace circuit breaker if defective (paragraph 9-23).**

STEP 6. Ensure 28 Vdc non-essential bus voltage is present through connector for TOW compartment blower (10B2).

**Replace blower if defective (paragraph 9-392).**

STEP 7. Ensure actuating voltage is present at terminal X1 and ground potential is present at terminal X1 and ground potential is present at terminal X2 of TOW blower relay (10K2). Check for bus voltage at terminals A1 and A2.

**Replace TOW COMP BLO RELAY (10K2) if defective (paragraph 9-16).**

**9-392. TOW BLOWER.****9-393. DESCRIPTION - TOW BLOWER.**

The TOW blower (10B2) powered by the 28 Vdc non-essential bus, provides cooling for the electronic equipment mounted on the TOW compartment shelf in the tailboom.

**9-394. CLEANING - TOW BLOWER.**

a. Remove moisture and loose dirt with a clean, soft cloth.

**WARNING**

**Cleaning solvent is flammable and toxic. Provide adequate ventilation. Avoid prolonged breathing of solvent vapors and contact with skin or eyes.**

b. Remove grease, fungus, and ground-in dirt with a clean, lint-free cloth dampened with dry cleaning solvent (C112).

c. Remove dirt from electrical connectors with a bristle brush.

**9-395. INSPECTION - TOW BLOWER.**

a. Inspect TOW blower for any visible damage, proper bonding, and security of mounting.

b. Check connectors for damaged or bent pins and cracked connector inserts.

c. Check brush caps for dents.

d. Check brushes for wear.

e. Check for proper operation.

f. Check case for cracks or damage.

**9-396. REMOVAL - TOW BLOWER.**

- a. Open access door.
- b. Disconnect electrical connector (10B2P1) from TOW blower. Protect receptacle and plug with caps or electrical tape (C121).
- c. Deleted.
- d. Remove mounting screws and washers securing TOW blower to bulkhead and remove TOW blower and screen assembly.

**9-397. REPAIR - TOW BLOWER.**

- a. Tighten or correct loose or improperly installed TOW blower.
- b. Replace or repair connectors and replace brush caps or brushes as necessary.
- c. Replace unit if case is cracked or damaged, or TOW blower is defective or inoperative.

**9-398. INSTALLATION - TOW BLOWER.**

- a. Position screen assembly and TOW blower in place on bulkhead and secure with mounting screws and washers.
- b. Deleted.
- c. Remove protective caps or electrical tape from electrical connectors and connect plug (10B2P1) to TOW blower receptacle.
- d. Close access door.

**9-399. RADIO BLOWER COOLING SYSTEM.**

**9-400. DESCRIPTION—RADIO BLOWER COOLING SYSTEM.**

The radio blower cooling system includes the radio blower (10B3), phasing capacitor (10C1), and radio blower overheat switch (10S6). The system receives power from the 115Vac bus through the RADIO BLO circuit breaker. The system cools the radio equipment on the right side of pilot station. When air temperature around equipment increases to approximately 43.3°C (110°F), the radio blower overheat switch (10S6) closes and energizes the radio blower. When air temperature decreases to approximately 35.5°C (96°F), the radio blower overheat switch opens and de-energizes radio blower.

**9-401. FUNCTIONAL TEST - RADIO BLOWER COOLING SYSTEM.**

- a. Ensure 115 Vac bus is energized.
- b. Position ELEC PWR-EMER OFF switch to ELEC PWR.
- c. Close RADIO BLO circuit breaker.
- d. Using a heat gun (hairdryer), heat the radio blower overheat switch being careful to not overheat surrounding components and equipment. After a few seconds check that radio blower is operating.
- e. Allow radio blower overheat switch to cool and check that radio blower ceases operating.

**9-402. TROUBLESHOOTING - RADIO BLOWER COOLING SYSTEM.**

Refer to paragraph F-9 in Appendix F for wiring diagram. Use table 9-32 and perform checks as necessary to isolate trouble. In the following table, tripped circuit breakers are omitted from indications of trouble. Such trouble is usually easily detected and corrected. Broken wiring is always a probable cause of circuit malfunction or failure and has not been included.



## NOTE

Before you use this table, be sure you have performed all normal operational checks. If you have a malfunction which is not listed in this table, notify the next higher level of maintenance.

Table 9-32. Troubleshooting Radio Blower Cooling System.

## CONDITION

## TEST OR INSPECTION

## CORRECTIVE ACTION

1. Radio blower (10B3) does not operate when radio equipment on right side of pilot compartment becomes too hot.

STEP 1. Ensure that 115 Vac is present at terminals T4 and T5 of radio blower and that terminal T1 is grounded.

**Replace radio blower motor (paragraph 9-403).**

STEP 2. Ensure that 115 Vac is present at radio blower overheat switch (10S6).

**Replace radio blower overheat switch (paragraph 9-8).**

**9-403. RADIO BLOWER.**

c. Remove dirt from electrical connector with a bristle brush.

**9-404. DESCRIPTION - RADIO BLOWER.**

The radio blower (1CB3) powered by the 115 Vac bus, provides cooling for the radio equipment mounted on the right side of the pilot compartment.

**9-406. INSPECTION - RADIO BLOWER.**

a. Inspect radio blower for any visible damage, proper bonding, and security of mounting.

**9-405. CLEANING - RADIO BLOWER.**

a. Remove moisture and loose dirt with a clean, soft cloth.

b. Check connectors for damaged or bent pins and cracked connector inserts.

**Cleaning solvent is flammable and toxic. Provide adequate ventilation. Avoid prolonged breathing of solvent vapors and contact with skin or eyes.**

c. Check brush caps for dents.

d. Check brushes for wear.

e. Check for proper operation.

f. Check case for cracks or damage.

b. Remove grease, fungus, and ground-in dirt with a clean, lint-free cloth dampened with dry cleaning solvent (C112).

**9-407. REMOVAL - RADIO BLOWER.**

a. Open access door.

b. Disconnect electrical connections from radio blower. Protect ends of wires with caps or electrical tape (C121).

c. Remove mounting screws and washers securing radio blower to bulkhead. Remove blower.

**9-408. REPAIR - RADIO BLOWER.**

a. Tighten or correct loose or improperly installed radio blower.

b. Replace or repair connector and wiring as required.

c. Replace unit if case is cracked, damaged, or radio blower is defective or inoperative.

**9-409. INSTALLATION - RADIO BLOWER.**

a. Position radio blower in place on bulkhead. Secure with mounting screws and washers.

b. Remove protective caps or electrical tape from electrical wires. Connect wires to appropriate terminal on motor.

c. Close access door.

**9-410. STABILITY AND CONTROL AUGMENTATION SYSTEM (SCAS).**

**9-411. DESCRIPTION - STABILITY AND CONTROL AUGMENTATION SYSTEM (SCAS).**

The SCAS is a three-axis stability and control augmentation system. It is integrated into fore and aft, lateral, and directional (anti-torque) flight controls to improve stability and handling qualities of helicopter. For a complete description and maintenance, refer to paragraph 11-98 for flight control portion and TM 11-1520-236 series maintenance manuals for complete information.

**SECTION VIII. P ARMAMENT SYSTEMS CIRCUITRY**

**9-412. P ARMAMENT SYSTEMS CIRCUITRY.**

**9-413. P DESCRIPTION - ARMAMENT SYSTEMS CIRCUITRY.**

The armament systems consist of the turret system, wing stores armament systems, M-136 helmet sight system, and M65 TOW missile subsystem. Functional test and troubleshooting procedures are presented for each armament subsystem circuitry. References are made to appropriate maintenance manuals and/or chapters within this maintenance manual, where applicable. See figure 9-19 for armament electrical equipment location illustrations and refer to paragraph F-9 in Appendix F for wiring diagrams.

supplement the appropriate armament wiring diagram and facilitate electrical troubleshooting. Tables 9-32.1 through 9-32.7 provide the switch positions that establish the weapon mode and the switches controlling relay action. Each table provides a different mode of weapon control. The operation of each relay is dependent on the weapon mode selected. The top portion of the table establishes the weapon mode. The lower portion of the table indicates that a relay is energized by an X under the controlling switch.

**b. Gunner Jettison Control Relay Matrix.** Table 9-32.8 shows the gunner wing stores jettison system operation. The 7- or 19-tube rocket launcher portion of the table defines the relays energized for jettison operation with 7- or 19-tube launchers installed. The 7-tube and tube-launched, optically-tracked, wire command link (TOW) launcher portion of the table defines the relays energized for jettison operation with TOW and 7-tube launchers installed.

**9-413.1 P ARMAMENT SYSTEM RELAYS.**

a. **Armament Relay Function Matrices.** The armament relay function matrices are designed to

Table 9-32.1 **P** Relay Matrix, Pilot in Control Mode

Pilot Switches			Gunner Switches					Control		Can		Using	
MASTER ARM	WPN CONT	WG ST ARM	PLT OVRD	WING STORES SELECT	TCP	SHC	Instrument Panel	Gunner	Pilot	Fire	Acquire Target for TSU	Sight	Weapon Switch
					MOOE SELECT	ACQ TRK STOW	PHS ACQ						
STBY and ARM	PILOT	INBD/OUTBD	OFF		OFF				Pilot	Turret		Helmet Sight	TRIGGER TURRET FIRE
										Wing Stores		Reflex	WING ARM FIRE

Relay	Pilot Switches							Gunner Switches					
	MASTER ARM		WPN CONT	WG ST ARM	WING ARM FIRE	TRIGGER TURRET FIRE		PLT OVRD	TCP	SHC	Left-Hand Grip TRIGGER		
	STBY	ARM	PILOT	INBD/OUTBD	Pressed	1 ST Detent	2 ND Detent		MODE SELECT	ACQ TRK STOW	1 ST Detent	2 ND Detent	
								OFF					OFF
1K5 Emer Hyd Sys Cent													
2K3 Armament Power						x	x						
19K1 Gun Clearing						x	x						
19K31 Master Arm		x											
19K59 Pilot/ Gunner Control			x										
19K72 40mm Trigger Enable						x	x						
19K80 Gunner Pilot Override													
19K81 Fixed/ Forward													
19K82 Pilot Trigger Disable													
19K83 Pilot Action Disable	x *												
19K84 Gunner Action Disable													
19K85 Pilot Trigger/Action Switch Disable													
19K86 Pilot Trigger and Action Switch Activate			x										
19K87 TOW/Turret													
19K88 Action Interrupt													
19K90 Gunner Pilot Override													
19K91 Gunner Armament Light Dimming													
19K92 Pilot Armament Light Dimming													
21K1 M-18 Power													

209475-883

Table 9-32.1 **P** Relay Matrix, Pilot in Control Mode (Cont)

Relay	Pilot Switches							Gunner Switches				
	MASTER ARM		WPN CONT	WG ST ARM	WING ARM FIRE	TRIGGER TURRET FIRE		PLT OVRO	TCP	SHC	Left-Hand Grip TRIGGER	
	STBY	ARM	PILOT	INBD/ OUTBD	Pressed	1 ST	2 ND	OFF	MODE SELECT	ACQ TRK STOW	1 ST	2 ND
						Detent	Detent		OFF	Detent	Detent	
21K2 Jettison Control												
21K3 Pilot Jettison Switch												
21K4 Pilot Jettison Control												
21K5 Gunner Jettison Control												
21K6 Wina Stores Disable												
21K7 Turret Interrupt					X							

X Relay energized.

\* Helmet must be connected.

209475-883-2

Table 9-32.2 P Relay Matrix, Pilot in Fixed Forward Mode

Pilot Switches			Gunner Switches					Control		Can		Using	
MASTER ARM	WPN CONT	WG ST ARM	PLT OVRD	WING STORES SELECT	TCP	SHC	Instrument Panel	Gunner	Pilot	Fire	Acquire Target for TSU	Sight	Weapon Switch
					MODE SELECT	ACQ TRK STOW	PHS ACQ						
STBY and ARM	FIXED	INBD/OUTBD	OFF		OFF				Pilot	Turret		Reflex	TRIGGER TURRET FIRE
										Wing Stores		Reflex	WING ARM FIRE

Relay	Pilot Switches								Gunner Switches										
	MASTER ARM		WPN CONT	WG ST ARM	WING ARM FIRE	TRIGGER TURRET FIRE			PLT OVRD	TCP	SHC	Left-Hand Grip TRIGGER							
	STBY	ARM	FIXED	INBD/OUTBD	Pressed	1ST Detent	2ND Detent	OFF	MODE SELECT	ACQ TRK STOW	1ST Detent	2ND Detent							
													OFF	OFF					
1K5 Emer Hyd Sys Cont																			
2K3 Armament Power						X	X												
19K1 Gun Clearing						X	X												
19K31 Master Arm		X																	
19K59 Pilot / Gunner Control																			
19K72 40mm Trigger Enable						X	X												
19K80 Gunner Pilot Override																			
19K81 Fixed / Forward			X																
19K82 Pilot Trigger Disable																			
19K83 Pilot Action Disable																			
19K84 Gunner Action Disable																			
19K85 Pilot Trigger / Action Switch Disable																			
19K86 Pilot Trigger and Action Switch Activate																			
19K87 TOW/Turret																			
19K88 Action Interrupt																			
19K90 Gunner Pilot Override																			
19K91 Gunner Armament Light Dimming																			
19K92 Pilot Armament Light Dimming																			
21K1 M-18 Power																			

Table 9-32.2 **P** Relay Matrix, Pilot in Fixed Forward Mode (Cont)

Relay	Pilot Switches							Gunner Switches				
	MASTER ARM		WPN CONT	WG ST ARM	WING ARM FIRE	TRIGGER TURRET FIRE		PLT OVRD	TCP	SHC	Left-Hand Grip TRIGGER	
	STBY	ARM	FIXED	INBD/ OUTBD	Pressed	1 ST Detent	2 ND Detent	OFF	MODE SELECT	ACQ TRK STOW	1 ST Detent	2 ND Detent
									OFF			
21K2 Jettison Control												
21K3 Pilot Jettison Switch												
21K4 Pilot Jettison Control												
21K5 Gunner Jettison Control												
21K6 Wing Stores Disable												
21K7 Turret Interrupt					X							

X Relay energized.

209475-898-2

Table 9-32.3 **P** Relay Matrix, Gunner in Control Mode — HSS Controlling Turret

Pilot Switches			Gunner Switches					Control		Can		Using	
MASTER ARM	WPN CONT	WG ST ARM	PLT OVRD	WING STORES SELECT	TCP	SHC	Instrument Panel	Gunner	Pilot	Fire	Acquire Target for TSU	Sight	Weapon Switch
					MODE SELECT	ACQ TRK STOW	PHS ACQ						
STBY and ARM	GUNNER	INBD/ OUTBD	OFF		TSU/ GUN	STOW		Gunner		Turret		Helmet Sight	Left-Hand Grip TRIGGER
									Pilot	Wing Stores		Reflex	WING ARM FIRE

Relay	Pilot Switches						Gunner Switches					
	MASTER ARM		WPN CONT	WG ST ARM	WING ARM FIRE	TRIGGER TURRET FIRE		PLT OVRD	TCP	SHC	Left-Hand Grip TRIGGER	
	STBY	ARM	GUNNER	INBD/ OUTBD	Pressed	1 ST Detent	2 ND Detent	OFF	MODE SELECT	ACQ TRK STOW	1 ST Detent	2 ND Detent
									TSU/ GUN	STOW		
1K5 Emer Hyd Sys Cont												
2K3 Armament Power											X	X
19K1 Gun Clearing											X	X
19K31 Master Arm		X										
19K59 Pilot / Gunner Control												
19K72 40mm Trigger Enable											X	X
19K80 Gunner Pilot Override												
19K81 Fixed / Forward												
19K82 Pilot Trigger Disable												
19K83 Pilot Action Disable												
19K84 Gunner Action Disable	X *											
19K85 Pilot Trigger / Action Switch Disable												
19K86 Pilot Trigger and Action Switch Activate												
19K87 TOW/Turret												
19K88 Action Interrupt												
19K90 Gunner Pilot Override												
19K91 Gunner Armament Light Dimming												
19K92 Pilot Armament Light Dimming												
21K1 M-18 Power												

209475-884-1

**Table 9-32.3 P Relay Matrix, Gunner in Control Mode — HSS Controlling Turret (Cont)**

Relay	Pilot Switches							Gunner Switches				
	MASTER ARM		WPN CONT	WG ST ARM	WING ARM FIRE	TRIGGER TURRET FIRE		PLT OVRD	TCP	SHC	Left-Hand Grip TRIGGER	
	STBY	ARM	GUNNER	INBD/ OUTBD	Pressed	1 ST Detent	2 ND Detent	OFF	MODE SELECT	ACQ TRK STOW	1 ST Detent	2 ND Detent
21K2 Jettison Control												
21K3 Pilot Jettison Switch												
21K4 Pilot Jettison Control												
21K5 Gunner Jettison Control												
21K6 Wing Stores Disable												
21K7 Turret Interrupt					X							

X Relay energized.

\* Helmet must be connected.

209475-884-2



Table 9-32.4 **P** Relay Matrix, Gunner in Control Mode — TSU Controlling Turret

Pilot Switches			Gunner Switches					Control		Can		Using	
MASTER ARM	WPN CONT	WG ST ARM	PLT OVRD	WING STORES SELECT	TCP	SHC	Instrument Panel	Gunner	Pilot	Fire	Acquire Target for TSU	Sight	Weapon Switch
					MODE SELECT	ACQ TRK STOW	PHS ACQ						
STBY and ARM	GUNNER	INBD/ OUTBD	OFF		TSU/ GUN	TRK		Gunner		Turret		TSU	Left-Hand Grip TRIGGER
									Pilot	Wing Stores	Reflex	WING ARM FIRE	

Relay	Pilot Switches							Gunner Switches					
	MASTER ARM		WPN CONT	WG ST ARM	WING ARM FIRE	TRIGGER TURRET FIRE		PLT OVRD	TCP	SHC	Left-Hand Grip TRIGGER		
	STBY	ARM	GUNNER	INBD/ OUTBD	Pressed	1 ST Detent	2 ND Detent	OFF	MODE SELECT	ACQ TRK STOW	1 ST Detent	2 ND Detent	
									TSU/ GUN	TRK			
1K5 Emer Hyd Sys Cont													
2K3 Armament Power											X	X	
19K1 Gun Clearing											X	X	
19K31 Master Arm		X											
19K59 Pilot / Gunner Control													
19K72 40mm Trigger Enable											X	X	
19K80 Gunner Pilot Override													
19K81 Fixed / Forward													
19K82 Pilot Trigger Disable													
19K83 Pilot Action Disable													
19K84 Gunner Action Disable													
19K85 Pilot Trigger / Action Switch Disable													
19K86 Pilot Trigger and Action Switch Activate													
19K87 TOW/Turret													
19K88 Action Interrupt													
19K90 Gunner Pilot Override													
19K91 Gunner Armament Light Dimming													
19K92 Pilot Armament Light Dimming													
21K1 M-18 Power													

209475-886-1

Table 9-32.4 **P** Relay Matrix, Gunner in Control Mode — TSU Controlling Turret (Cont)

Relay	Pilot Switches							Gunner Switches				
	MASTER ARM		WPN CONT	WG ST ARM	WING ARM FIRE	TRIGGER TURRET FIRE		PLT OVRD	TCP	SHC	Left-Hand Grip TRIGGER	
	STBY	ARM	GUNNER	INBD/OUTBD	Pressed	1 ST Detent	2 ND Detent	OFF	MODE SELECT	ACQ TRK STOW	1 ST Detent	2 ND Detent
									TSU/GUN	TRK		
21K2 Jettison Control												
21K3 Pilot Jettison Switch												
21K4 Pilot Jettison Control												
21K5 Gunner Jettison Control												
21K6 Wing Stores Disable												
21K7 Turret Interrupt					X							

X Relay energized.

209475-886-2

Table 9-32.5 **P** Relay Matrix, Gunner Controlling TOW and Pilot Controlling Turret and Wing Stores Mode

Pilot Switches			Gunner Switches					Control		Can		Using	
MASTER ARM	WPN CONT	WG ST ARM	PLT OVRD	WING STORES SELECT	TCP	SHC	Instrument Panel	Gunner	Pilot	Fire	Acquire Target for TSU	Sight	Weapon Switch
					MODE SELECT	ACQ TRK STOW	PHS ACQ						
STBY and ARM	GUNNER	INBD/ OUTBD	OFF		STBY TOW/ ARMED	TRK			Pilot	Turret		Helmet Sight	TRIGGER TURRET FIRE
										Wing Stores		Reflex	WING ARM FIRE
											TOW		TSU

Relay	Pilot Switches							Gunner Switches						
	MASTER ARM		WPN CONT	WG ST ARM	WING ARM FIRE	TRIGGER TURRET FIRE		PLT OVRD	TCP	SHC	Left-Hand Grip TRIGGER			
	STBY	ARM	GUNNER	INBD/ OUTBD	Pressed	1 ST Detent	2 ND Detent	OFF	MODE SELECT	ACQ TRK STOW	TRK	1 ST Detent	2 ND Detent	
														STBY TOW/ ARMED
1K5 Emer Hyd Sys Cont														
2K3 Armament Power						X	X							
19K1 Gun Clearing						X	X							
19K31 Master Arm		X												
19K59 Pilot / Gunner Control									X					
19K72 40mm Trigger Enable						X	X							
19K80 Gunner Pilot Override														
19K81 Fixed / Forward														
19K82 Pilot Trigger Disable												X		
19K83 Pilot Action Disable	X *													
19K84 Gunner Action Disable														
19K85 Pilot Trigger / Action Switch Disable												X		
19K86 Pilot Trigger and Action Switch Activate									X					
19K87 TOW/Turret									X					
19K88 Action Interrupt														
19K90 Gunner Pilot Override														
19K91 Gunner Armament Light Dimming														
19K92 Pilot Armament Light Dimming														

209475-885-1

Table 9-32.5 **P** Relay Matrix, Gunner Controlling TOW and Pilot Controlling Turret and Wing Stores Mode (Cont)

Relay	Pilot Switches						Gunner Switches					
	MASTER ARM		WPN CONT	WG ST ARM	WING ARM FIRE	TRIGGER TURRET FIRE		PLT OVRD	TCP	SHC	Left-Hand Grip TRIGGER	
	STBY	ARM	GUNNER	INBD/ OUTBD	Pressed	1 ST Detent	2 ND Detent	OFF	MODE SELECT	ACQ TRK STOW	1 ST Detent	2 ND Detent
									STBY TOW/ ARMED	TRK		
21K1 M-18 Power	X											
21K2 Jettison Control												
21K3 Pilot Jettison Switch												
21K4 Pilot Jettison Control												
21K5 Gunner Jettison Control												
21K6 Wing Stores Disable											X	
21K7 Turret Interrupt					X							

X Relay energized.

\* Helmet must be connected.

209475-885-2

Table 9-32.6 **P** Relay Matrix, TSU Acquisition of Target with Gunner or Pilot HSS Mode

Pilot Switches			Gunner Switches					Control		Can		Using	
MASTER ARM	WPN CONT	WG ST ARM	PLT OVRD	WING STORES SELECT	TCP	SHC	Instrument Panel	Gunner	Pilot	Fire	Acquire Target for TSU	Sight	Weapon Switch
					MODE SELECT	ACQ TRK STOW							
STBY and ARM	GUNNER	INBD/ OUTBD	OFF		TSU/ GUN	ACQ		Gunner			Acquire	Gunner Helmet Sight	
						TRK	Pressed	Gunner			Acquire	Pilot Helmet Sight	

Relay	Pilot Switches						Gunner Switches						
	MASTER ARM		WPN CONT	WG ST ARM	WING ARM FIRE	TRIGGER TURRET FIRE		PLT OVRD	TCP	SHC	Left-Hand Grip TRIGGER		PHS ACQ
	STBY	ARM	GUNNER	INBD/ OUTBD		1 ST Detent	2 ND Detent		MODE SELECT	ACQ TRK STOW	1 ST Detent	2 ND Detent	Pressed
								TSU/ GUN	ACQ				
1K5 Emer Hyd Sys Cont													
2K3 Armament Power													
19K1 Gun Clearing													
19K31 Master Arm		X											
19K59 Pilot / Gunner Control													
19K72 40mm Trigger Enable													
19K80 Gunner Pilot Override													
19K81 Fixed / Forward													
19K82 Pilot Trigger Disable													
19K83 Pilot Action Disable	X *												
19K84 Gunner Action Disable	X *												
19K85 Pilot Trigger / Action Switch Disable													
19K86 Pilot Trigger and Action Switch Activate													
19K87 TOW/Turret													
19K88 Action Interrupt									X				X
19K90 Gunner Pilot Override													
19K91 Gunner Armament Light Dimming													
19K92 Pilot Armament Light Dimming													
21K1 M-18 Power													

209475-887-1

Table 9-32.6 **P** Relay Matrix, TSU Acquisition of Target with Gunner or Pilot HSS Mode (Cont)

Relay	Pilot Switches						Gunner Switches						
	MASTER ARM		WPN CONT	WG ST ARM	WING ARM FIRE	TRIGGER TURRET FIRE		PLT OVRD	TCP	SHC	Left-Hand Grip TRIGGER		PHS ACQ
	STBY	ARM	GUNNER	INBD/OUTBD		1 ST Detent	2 ND Detent	OFF	MODE SELECT	ACQ TRK STOW	1 ST Detent	2 ND Detent	Pressed
									TSU/GUN	ACQ			
21K2 Jettison Control													
21K3 Pilot Jettison Switch													
21K4 Pilot Jettison Control													
21K5 Gunner Jettison Control													
21K6 Wing Stores Disable													
21K7 Turret Interrupt													

X Relay energized.

\* Helmet must be connected.

209475-887-2

Table 9-32.7 **P** Relay Matrix, Pilot Override Mode

Pilot Switches			Gunner Switches					Control		Can		Using	
MASTER ARM	WPN CONT	WG ST ARM	PLT OVRD	WING STORES SELECT	TCP	SHC	Instrument Panel	Gunner	Pilot	Fire	Acquire Target for TSU	Sight	Weapon Switch
					MODE SELECT	ACQ TRK STOW	PHS ACQ						
			PLT OVRD	INBD/OUTBD	OFF					Turret		Helmet Sight	TRIGGER TURRET FIRE
										Wing Stores		None	WING ARM FIRE

Relay	Pilot Switches						Gunner Switches						
	MASTER ARM		WPN CONT	WG ST ARM	WING ARM FIRE	TRIGGER TURRET FIRE		PLT OVRD	TCP	SHC	TRIGGER TURRET FIRE		WING ARM FIRE
	STBY	ARM	PILOT or GUNNER	INBD/OUTBD		1 ST Detent	2 ND Detent	PLT OVRD	MODE SELECT	ACQ TRK STOW	1 ST Detent	2 ND Detent	Pressed
1K5 Emer Hyd Sys Cont													
2K3 Armament Power										X	X		
19K1 Gun Clearing										X	X		
19K31 Master Arm							X						
19K59 Pilot / Gunner Control													
19K72 40mm Trigger Enable										X	X		
19K80 Gunner Pilot Override							X						
19K81 Fixed / Forward													
19K82 Pilot Trigger Disable													
19K83 Pilot Action Disable													
19K84 Gunner Action Disable								X *					
19K85 Pilot Trigger / Action Switch Disable													
19K86 Pilot Trigger and Action Switch Activate													
19K87 TOW/Turret													
19K88 Action Interrupt													
19K90 Gunner Pilot Override							X						
19K91 Gunner Armament Light Dimming													
19K92 Pilot Armament Light Dimming													
21K1 M-18 Power													

209475-888-1

Table 9-32.7 **P** Relay Matrix, Pilot Override Mode (Cont)

Relay	Pilot Switches							Gunner Switches					
	MASTER ARM		WPN CONT	WG ST ARM	WING ARM FIRE	TRIGGER TURRET FIRE		PLT OVRD	TCP	SHC	TRIGGER TURRET FIRE		WING ARM FIRE
	STBY	ARM	PILOT or GUNNER	INBD/ OUTBD		1 ST Detent	2 ND Detent	PLT OVRD	MODE SELECT	ACQ TRK STOW	1 ST Detent	2 ND Detent	Pressed
									OFF				
21K2 Jettison Control													
21K3 Pilot Jettison Switch													
21K4 Pilot Jettison Control													
21K5 Gunner Jettison Control													
21K6 Wing Stores Disable													
21K7 Turret Interrupt													X

X Relay energized.

\* Helmet must be connected.

209475-888-2



Table 9-32.8 **P** Relay Matrix, Gunner Jettison Mode



Ensure jettison cartridges are removed from ejector racks before performing checks.

NOTE

Ensure WING STORES JTSN, GNR JTSN, and PLT JTSN circuit breakers are closed.

7-or 19-Tube Rocket Launcher -4 Stations					
Relay	Gunner Instrument Panel				
	WING STORES JETTISON Switch		JTSN SEL Switch		
	off	On	OUTBD	BOTH	INBD
21 KS Gunner Jettison Control		On		X	X

TOW Launcher Outboard -7 -Tube Rocket Launcher Inboard					
Relay	Gunner Instrument Panel				
	WING STORES JETTISON Switch		JTSN SEL Switch		
	off	On	OUTBD	BOTH	INBD
21K2 Jettison Control	*	*	*	*	*
21K5 Gunner Jettison Control		O n		X**	X**

x Relay energized

\* Relay 21K2 is not controlled by any switch; rather, it is energized anytime right or left lower outboard TOW launcher is electrically connected.

• \* Relay 21K5 cannot be energized if 21K2 is energized.

Table 9-32.9 **P** Relay Matrix, Pilot Jettison Mode



Ensure jettison cartridges are removed from ejector racks before performing checks.

NOTE

Ensure WING STORES JTSN, GNR JTSN, and PLT JTSN circuit breakers are closed.

7- or 19-Tube Rocket Launcher – 4 Stations			
Relay	Pilot Collective	Pilot Misc Control Panel	
	JETTISON Switch	JETTISON SELECT	
	Pressed	OUTBD	INBD
<b>21K3 Pilot Jettison Switch</b>	X		
<b>21K4 Pilot Jettison Control</b>			X

TOW Launcher Outboard – 7 -Tube Rocket Launcher Inboard			
Relay	Pilot Collective	Pilot Misc Control Panel	
	JETTISON Switch	JETTISON SELECT	
	Pressed	OUTBD	INBD
<b>21K2 Jettison Control</b>	*	*	*
<b>21K3 Pilot Jettison Switch</b>	X		
<b>21K4 Pilot Jettison Control</b>			X**

x Relay energized

\* Relay 21K2 is not controlled by any switch; rather, it is energized anytime right or left lower outboard TOW launcher is electrically connected.

\*\* Relay 21K4 cannot be energized if 21K2 is energized; also, relay 21K4 cannot be energized unless 21K3 is energized.

209475-881

**c. Pilot Jettison Control Relay Matrix.** Table 9-32.9 shows the pilot wing stores jettison system operation. The 7- or 19-tube rocket launcher portion of the table defines the relays energized for jettison operation with 7- or 19-tube launchers installed. The 7-tube and TOW launcher portion of the table defines the relays energized for jettison operation with TOW and 7-tube launchers installed.

**d. Armament System Relay Locations.** Relay locations are shown in Appendix F, figure F-18.1.

## 9-413.2 **P** DESCRIPTION - ARMAMENT SYSTEM RELAYS.

### a. 1K5 - Emergency Hydraulic System Control Relay.

**(1) Purpose.** To enable activation of emergency hydraulic pump when pressure is lost in hydraulic system 2.

**(2) Function.** The primary function of this relay is to turn on the emergency hydraulic pump relay to provide hydraulic pressure for flight controls. The secondary function is to turn off power to the TOW launcher hydraulic solenoid and turret hydraulic solenoid. This relay is bypassed in the boresight function for ground operation when boresighting the TOW launchers. This is a 10-amp, 4-pole, socket-mounted relay.

#### **(3) Relay contact logic.**

**(a) Contacts A.** Contacts A are used in the deenergized position to supply voltage to the TOW launcher hydraulic solenoid from the servo electronic control unit (SECU). These contacts are open when the relay is energized.

**(b) Contacts B.** Contacts B are used in the deenergized position to supply voltage to the armament hydraulic solenoid (19L1) from the turret control system. These contacts are open when the relay is energized.

**(c) Contacts C.** Contacts C are used in the energized position to control the emergency hydraulic pump relay (1K4).

**(d) Contacts D.** Contacts D are not used.

### b. 2K3 - Armament Power Relay.

**(1) Purpose** To provide power to the M-28 turret to drive the guns.

**(2) Function.** This relay is controlled by the gun clearing relay (19K1) to supply battery voltage to the turret for gun drive. This is a 200-amp, single-pole relay.

**(3) Relay contact logic.** Contacts are used to connect the battery bus to the gun control assemblies.

### c. 19K1 - Gun Clearing Relay.

**(1) Purpose.** To disconnect the battery from the generator bus and connect it to the gun control for firing.

**(2) Function.** To provide battery power to drive the gun motors and to maintain the voltage for 0.5 second after the TRIGGER TURRET FIRE switch is released to provide gun clearing. This is a 10-amp, 2-pole, time-delay-on-dropout relay. The delay time is 0.5 second.

#### **(3) Relay contact logic.**

**(a) Contacts A.** Contacts A (pins H, D, and G) open the battery relay (2K2) to remove the battery from the bus.

**(b) Contacts B.** Contacts B (pins C, F, and B) close the armament power relay (2K3) to apply the battery to the left and right gun speed control box for firing the gun.

### d. 19K31 - Master Arm Relay.

**(1) Purpose.** To provide master arm power to the wing stores system and to control status indicators.

**(2) Function.** The master arm relay is controlled by the MASTER ARM switch. Master arm power is required to fire any weapon. This is a 10-amp, 4-pole, screw-terminal relay.

#### **(3) Relay contact logic.**

**(a) Contacts A.** Contacts A are used in the energized position to turn on the ARMED light in the pilot and gunner armament control panels.

**(b) Contacts B.** Contacts B are used in the deenergized position to light the STBY light. In the energized position, the STBY light is turned off.

**(c) Contacts C.** Contacts C are not used.

**(d) Contacts D.** Contacts D are used in the energized position to provide arm power to the wing stores system.

**e. 19K59 - Pilot/Gunner Control Relay.**

**(1) Purpose.** To switch the turret weapon and indicator lights from gunner to pilot.

**(2) Function.** The control of TURRET SELECT switch and 7.62 and 40 lights is switched automatically to the pilot anytime the pilot has control of the turret. This is a 10-amp, 6-pole, socket-mounted relay.

**(3) Relay contact logic.**

**(a) Contacts A - deenergized.** Contacts A in the deenergized position allow selection of the right turret weapon by the gunner.

**(b) Contacts A - energized.** Contacts A in the energized position allow selection of the right turret weapon by the pilot.

**(c) Contacts B - deenergized.** Contacts B in the deenergized position allow selection of the left turret weapon by the gunner.

**(d) Contacts B - energized.** Contacts B in the energized position allow selection of the left turret weapon by the pilot.

**(e) Contacts C - deenergized.** Contacts C in the deenergized position will illuminate the left 7.62 light on the gunner armament control panel if a 7.62-mm gun is installed on the left side of the turret.

**(f) Contacts C - energized.** Contacts C in the energized position will illuminate the left 7.62 light on the pilot armament control panel if a 7.62-mm gun is installed on the left side of the turret.

**(g) Contacts D - deenergized.** Contacts D in the deenergized position will illuminate the left 40 light on the gunner armament control panel if a 40-mm launcher is installed on the left side of the turret.

**(h) Contacts D - energized.** Contacts D in the energized position will illuminate the left 40 light on the pilot armament control panel if a 40-mm launcher is installed on left side of the turret.

**(i) Contacts E - deenergized.** Contacts E in the deenergized position will illuminate the right 7.62 light on the gunner armament control panel if a 7.62-mm gun is installed on the right side of the turret.

**(j) Contacts E - energized.** Contacts E in the energized position will illuminate the right 7.62 light on the pilot armament control panel if a 7.62-mm gun is installed on the right side of the turret.

**(k) Contacts F - deenergized.** Contacts F in the deenergized position will illuminate the right 40 light on the gunner armament control panel if a 40-mm launcher is installed on the right side of the turret.

**(l) Contacts F - energized.** Contacts F in the energized position will illuminate the right 40 light on the pilot armament control panel if a 40-mm launcher is installed on the right side of the turret.

**f. 19K72 - 40-mm Trigger Enable Relay.**

**(1) Purpose.** To allow the 40-mm launcher to be fired from the cyclic grip or telescopic sight unit (TSU) left-hand grip (LHG).

**(2) Function.** To apply the trigger signal to the 40-mm launcher circuit anytime it is applied to the 7.62-mm gun circuit and allow either weapon, that is installed and selected, to fire. This is a 10-amp, 2-pole, socket-mounted relay.

**(3) Relay contact logic.**

**(a) Contacts A - deenergized.** Contacts A in the deenergized position are open.

**(b) Contacts A - energized.** Contacts A in the energized position apply the trigger signal to the 40-mm launcher input on the turret control.

**(c) Contacts B.** Contacts B are not used.

**g. 19K80 - Gunner Pilot Override Relay.**

**(1) Purpose.** To allow the gunner to take control of the weapons system if the pilot is disabled and to arm the system if the pilot has not armed it.

**(2) Function.** The override mode allows the gunner to fire the turret and rockets from his cyclic grip while flying the helicopter. This is a 10-amp, 6-pole, socket-mounted relay.

**(3) Relay contact logic.**

**(a) Contacts A - deenergized.** Contacts A in the deenergized position provide standby power to the pilot WPN CONT switch.

**(b) Contacts A - energized.** Contacts A in the energized position provide standby power to the gunner cyclic TRIGGER ACTION switch and the electronic control assembly.

**(c) Contacts B - deenergized.** Contacts B in the deenergized position provide arm power to the pilot WPN CONT switch.

**(d) Contacts B - energized.** Contacts B in the energized position provide arm power to the gunner TRIGGER TURRET FIRE switch.

**(e) Contacts C - deenergized.** Contacts C in the deenergized position provide weapon fire voltage to the pilot WING ARM FIRE switch.

**(f) Contacts C - energized.** Contacts C in the energized position provide weapon fire voltage to the gunner WING ARM FIRE switch.

**(g) Contacts D - deenergized.** Contacts D in the deenergized position provide power from the pilot WPN CONT switch to the gunner TURRET SELECT switch.

**(h) Contacts D - energized.** Contacts D in the energized position provide arm power directly to the gunner TURRET SELECT switch.

**(i) Contacts E - deenergized.** Contacts E in the deenergized position are open.

**(j) Contacts E - energized.** Contacts E in the energized position apply weapon fire voltage to C contacts of relay 19K80.

**(k) Contacts F - deenergized.** Contacts F in the deenergized position supply weapon control voltage to the TOW control panel.

**(l) Contacts F - energized.** Contacts F in the energized position open the circuit to the TOW system

and provide weapon control voltage to the turret and wing stores.

**h. 19K81 - Fixed/Forward Relay.**

**(1) Purpose.** To switch added circuits when the pilot WPN CONT switch is in the FIXED position.

**(2) Function.** To open the turret action circuit and switch the pilot cyclic TRIGGER TURRET FIRE switch to the fixed mode. This is a 10-amp, 4-pole, socket-mounted relay.

**(3) Relay contact logic.**

**(a) Contacts A - deenergized.** Contacts A in the deenergized position connect the pilot TRIGGER TURRET FIRE switch (first detent) to the same point as the gunner TRIGGER TURRET FIRE switch (first detent) so that the trigger that is enabled will fire the turret weapon.

**(b) Contacts A - energized.** Contacts A in the energized position connect the pilot TRIGGER TURRET FIRE switch (first detent) directly to the electronic control assembly for forward firing.

**(c) Contacts B - deenergized.** Contacts B in the deenergized position connect the pilot TRIGGER TURRET FIRE switch (second detent) to the same point as the gunner TRIGGER TURRET FIRE switch (second detent) so that the trigger that is enabled will fire the turret weapon.

**(d) Contacts B - energized.** Contacts B in the energized position connect the pilot TRIGGER TURRET FIRE switch (second detent) directly to the electronic control assembly for forward firing.

**(e) Contacts C - deenergized.** Contacts C in the deenergized position connect the pilot TRIGGER ACTION switch to the same point as the gunner TRIGGER ACTION switch circuit so that the TRIGGER ACTION switch that is enabled will control the turret.

**(f) Contacts C - energized.** Contacts C in the energized position are an open circuit, since the action signal is not needed for fixed forward firing.

**(g) Contacts D.** Contacts D are not used.

**i. 19K82 - Pilot Trigger Disable Relay.**

**(1) Purpose.** Relays 19K82 and 19K85 are used together to provide a controlled sequence to interrupt the turret during TOW missile launch.

**(2) Function.** Relay 19K82 is controlled by the launcher activate signal from the TOW stabilization control amplifier (SCA) and provides a ground for the coil of 19K85. This is a 10-amp, 2-pole, time-delay-on-dropout relay. The delay time is set at 0.5 second.

**(3) Relay contact logic.**

**(a) Contacts A.** Contacts A (pins B, F, and C) in the energized position provide a ground for the coil of 19K85 relay.

**(b) Contacts B.** Contacts B (pins G, D and H) are not used.

**j. 19K83 - Pilot Action Disable Relay.**

**(1) Purpose.** To detect separation of pilot helmet sight from the control arm.

**(2) Function.** To open the pilot action circuit to the turret and turn off the sight reticle if the arm is disconnected from the pilot helmet. This is a 10-amp, 2-pole, socket-mounted relay.

**(3) Relay contact logic.**

**(a) Contacts A - deenergized.** Contacts A in the deenergized position open the pilot action circuit to the turret.

**(b) Contacts A - energized.** Contacts A in the energized position complete the circuit from the pilot TRIGGER ACTION switch to the turret.

**(c) Contacts B - deenergized.** Contacts B in the deenergized position open the ground circuit to the pilot helmet sight reticle.

**(d) Contacts B - energized.** Contacts B in the energized position complete the ground circuit to the pilot helmet sight reticle.

**k. 19K84 - Gunner Action Disable Relay.**

**(1) Purpose.** To detect separation of gunner helmet sight from the sight control arm.

**(2) Function.** To open the gunner action circuit to the turret and turn off the helmet sight reticle if the control arm is disconnected from the helmet. This is a 10-amp, 4-pole, socket-mounted relay.

**(3) Relay contact logic.**

**(a) Contacts A - deenergized.** Contacts A in the deenergized position open the action circuit from the gunner TRIGGER ACTION switch to the turret.

**(b) Contacts A - energized.** Contacts A in the energized position close the action circuit to the gunner TRIGGER ACTION switch to allow turret control when in the PLT OVRD mode.

**(c) Contacts B - deenergized.** Contacts B in the deenergized position provide the action signal to the interface control unit (IFCU) from the left-hand grip (LHG) when the helmet sight is disconnected to allow the TSU to control the turret.

**(d) Contacts B - energized.** Contacts B in the energized position provide the action signal from the left-hand grip to the turret.

**(e) Contacts C - deenergized.** Contacts C in the deenergized position open the ground circuit to the gunner helmet sight reticle.

**(f) Contacts C - energized.** Contacts C in the energized position complete the ground circuit to the gunner helmet sight reticle.

**(g) Contacts D.** Contacts D are not used.

**l. 19K85 - Pilot Trigger/Action Switch Disable Relay.**

**(1) Purpose.** To disable pilot TRIGGER TURRET FIRE and TRIGGER ACTION switches during TOW missile launch.

**(2) Function.** The TOW trigger signal will energize 19K85 if 19K82 is closed. This provides a controlled interrupt sequence of the pilot trigger and action circuitry to the turret of approximately 3.0 seconds during TOW missile launch. This is a 10-amp, 2-pole, socket-mounted relay.

**(3) Relay contact logic.**

**(a) Contacts A - deenergized.** Contacts A in the deenergized position provide standby power to the pilot TRIGGER ACTION switch.

**(b) Contacts A - energized.** Contacts A in the energized position open the standby power circuit to the pilot TRIGGER ACTION switch.

**(c) Contacts B - deenergized.** Contacts B in the deenergized position provide power to the pilot TRIGGER TURRET FIRE switch when in the TOW mode.

**(d) Contacts B - energized.** Contacts B in the energized position apply power to the coil of 19K85 and latch it in. It will remain latched in until 19K82 opens the ground on the coil.

**m. 19K86 - Pilot Trigger and Action Switch Activate Relay.**

**(1) Purpose.** To provide the pilot control of the turret when the gunner is in TOW mode.

**(2) Function.** To provide voltage to the pilot TRIGGER ACTION and TRIGGER TURRET FIRE switches when a TOW mode is selected by the gunner. This is a 10-amp, 2-pole, socket-mounted relay.

**(3) Relay contact logic.**

**(a) Contacts A - deenergized.** Contacts A in the deenergized position are open.

**(b) Contacts A - energized.** Contacts A in the energized position provide a voltage to the pilot TRIGGER ACTION switch.

**(c) Contacts B - deenergized.** Contacts B in the deenergized position are open.

**(d) Contacts B - energized.** Contacts B in the energized position are used to provide a voltage to the pilot TRIGGER TURRET FIRE switch.

**n. 19K87 - TOW/Turret Relay.**

**(1) Purpose.** To transfer the gunner TSU left-hand grip (LHG) TRIGGER switch circuit from the turret to the TOW system.

**(2) Function.** Selection of a standby or armed mode on the TOW control panel will energize the TOW/turret relay (19K87) and control 19K86 to give the pilot control of the turret.

**(3) Relay contact logic.**

**(a) Contacts A - deenergized.** Contacts A in the deenergized position are in the circuit from the gunner TSU left-hand grip (LHG) ACTION switch to the turret.

**(b) Contacts A - energized.** Contacts A in the energized position open the left-hand grip (LHG) ACTION switch circuit.

**(c) Contacts B - deenergized.** Contacts B in the deenergized position are open.

**(d) Contacts B - energized.** Contacts B in the energized position control 19K86 to switch control of the turret to the pilot TRIGGER TURRET FIRE and TRIGGER ACTION switches.

**(e) Contacts C - deenergized.** Contacts C in the deenergized position are in the circuit from the TSU left-hand grip (LHG) TRIGGER switch (second detent) to the turret.

**(f) Contacts C - energized.** Contacts C in the energized position open the TSU left-hand grip (LHG) TRIGGER switch (second detent) circuit.

**(g) Contacts D - deenergized.** Contacts D in the deenergized position are in the circuit from the TSU left-hand grip (LHG) TRIGGER switch (first detent) to the turret.

**(h) Contacts D - energized.** Contacts D in the energized position open the TSU left-hand grip (LHG) TRIGGER switch (first detent) circuit from the turret and connect it to the TOW system.

**o. 19K88 - Action Interrupt Relay.**

**(1) Purpose.** To open the action circuit to the turret during acquisition mode.

**(2) Function.** This relay is controlled by the gunner acquisition switches, either pilot or gunner, to open the turret action circuit when a sight signal is not available to the turret. This is a 10-amp, 2-pole, socket-mounted relay.

**(3) Relay contact logic.**

**(a) Contacts A - deenergized.** Contacts A in the deenergized position are in the action circuit to the turret.

**(b) Contacts A - energized.** Contacts A in the energized position open the action circuit to the turret.

**(c) Contacts B.** Contacts B are not used.

**p. 19K90 - Gunner Pilot Override Relay.**

**(1) Purpose.** To allow the gunner to control his night vision lighting from the cyclic grip LTS switch when in the override mode.

**(2) Function.** To switch night vision lighting control from the gunner miscellaneous control panel to the gunner cyclic grip when in the override mode. This is a 10-amp, 2-pole, socket-mounted relay.

**(3) Relay contact logic.**

**(a) Contacts A - deenergized.** Contacts A in the deenergized position allow the LT switch on the gunner miscellaneous control panel to control gunner night vision lighting.

**(b) Contacts A - energized.** Contacts A in the energized position allow the LTS switch on the gunner cyclic grip to control gunner night vision lighting.

**(c) Contacts B.** Contacts B are not used.

**q. 19K91 - Gunner Armament Light Dimming Relay.**

**NOTE**

NVG light dimming system will be deactivated with the incorporation of MWO 55-1520-236-50-4.

**(1) Purpose.** To provide automatic dimming of the gunner armament lights when night vision goggles (NVG) mode is selected.

**(2) Function.** To switch the gunner armament lights from bright to dim. This is a 10-amp, 6-pole, socket-mounted relay.

**(3) Relay contact logic.**

**(a) Contacts A.** Contacts A switch the gunner STBY light from bright to dim.

**(b) Contacts B.** Contacts B switch the gunner ARMED light from bright to dim.

**(c) Contacts C.** Contacts C switch the gunner left 7.62 light from bright to dim if a 7.62-mm gun is installed on the left side of the turret.

**(d) Contacts D.** Contacts D switch the gunner left 40 light from bright to dim if a 40-mm launcher is installed on the left side of the turret.

**(e) Contacts E.** Contacts E switch the gunner right 7.62 light from bright to dim if a 7.62-mm gun is installed on the right side of the turret.

**(f) Contacts F.** Contacts F switch the gunner right 40 light from bright to dim if a 40-mm launcher is installed on the right side of the turret.

**r. 19K92 - Pilot Armament Light Dimming Relay.**

**NOTE**

NVG light dimming system will be deactivated with the incorporation of MWO 55-1520-236-50-4.

**(1) Purpose.** To provide automatic dimming of the pilot armament lights when NVG mode is selected.

**(2) Function.** To switch the pilot armament lights from bright to dim. This is a 10-amp, 6-pole, socket-mounted relay.

**(3) Relay contact logic.**

**(a) Contacts A.** Contacts A switch the pilot STBY light from bright to dim.

**(b) Contacts B.** Contacts B switch the pilot ARMED light from bright to dim.

**(c) Contacts C.** Contacts C switch the pilot left 7.62 light from bright to dim if a 7.62-mm gun is installed on the left side of the turret.

**(d) Contacts D.** Contacts D switch the pilot left 40 light from bright to dim if a 40-mm launcher is installed on the left side of the turret.

**(e) Contacts E.** Contacts E switch the pilot right 7.62 light from bright to dim if a 7.62-mm gun is installed on the right side of the turret.

**(f) Contacts F.** Contacts F switch the pilot right 40 light from bright to dim if a 40-mm launcher is installed on the right side of the turret.



**s. 21K1 - M-18 Power Relay.**

**(1) Purpose.** To provide power to the inboard wing stations for M-18 battery charging.

**(2) Function.** This relay is energized anytime the MASTER ARM switch is in the STBY position. This is a 20-amp, 3-pole, screw-terminal relay.

**(3) Relay contact logic.**

**(a) Contacts A.** Contacts A in the energized position apply power from the RH MINI GUN circuit breaker to the inboard right wing station for M-18 battery charging.

**(b) Contacts B.** Contacts B in the energized position apply power from the LH MINI GUN circuit breaker to the inboard left wing station for M-18 battery charging.

**(c) Contacts C.** Contacts C are not used.

**t. 21K2 - Jettison Control Relay.**

**(1) Purpose.** To prevent jettison of an inboard wing store if lower missile launchers are installed outboard.

**(2) Function.** Relay 21K2 will open the inboard jettison circuits and route the jettison signal to the outboard stations if inboard stores are selected for jettison when lower missile launchers are installed. When the electrical connector of each lower missile launcher separates, relay 21K2 will reenergize and route the jettison signal to the inboard stations. This is a 10-amp, 2-pole, socket-mounted relay.

**(3) Relay contact logic.**

**(a) Contacts A - deenergized.** Contacts A in the deenergized position connect the pilot inboard stores jettison circuits to the inboard stations.

**(b) Contacts A - energized.** Contacts A in the energized position open the pilot inboard stores jettison circuits and send the inboard jettison signal to the outboard stores stations.

**(c) Contacts B - deenergized.** Contacts B in the deenergized position connect the gunner inboard stores jettison circuits to the inboard stores stations.

**(d) Contacts B - energized.** Contacts B in the energized position open the gunner inboard stores jettison circuits and send the inboard jettison signal to the outboard stores stations.

**u. 21K3 - Pilot Jettison Switch Relay.**

**(1) Purpose.** To ensure the pilot jettison signal is maintained long enough for jettison sequence completion.

**(2) Function.** When the pilot releases his JETTISON pushbutton switch, 21K3 will maintain the jettison command for 1.0 second. This is a 10-amp, 2-pole, time-delay-on-dropout relay. The time delay is 1.0 second.

**(3) Relay contact logic.**

**(a) Contacts A.** Contacts A (pins H, D, and G) apply voltage to the pilot JETTISON SELECT switches when the relay is energized.

**(b) Contacts B.** Contacts B (pins C, F, and B) are not used.

**v. 21K4 - Pilot Jettison Control Relay.**

**(1) Purpose.** To prevent simultaneous jettison of inboard and outboard wing stores. Inboard stores are always delayed for 0.5 second.

**(2) Function.** When the pilot presses the JETTISON pushbutton switch, 21K4 relay will delay for 0.5 second and then energize and send a signal to the inboard stations to jettison stores. This is a 10-amp, 2-pole, time-delay-on-pull-in relay. The time delay is 0.5 second.

**(3) Relay contact logic.**

**(a) Contacts A.** Contacts A (pins C, F, and B) are not used.

**(b) Contacts B.** Contacts B (pins H, D, and G) close after 0.5 second and apply voltage to the inboard stores jettison circuits.

**w. 21K5 - Gunner Jettison Control Relay.**

**(1) Purpose.** To prevent simultaneous jettison of inboard and outboard wing stores. Inboard stores are always delayed for 0.5 second.

**(2) Function.** This relay delays the gunner inboard stores jettison signal for 0.5 second and then sends it to the inboard stations to jettison stores. This is a 10-amp, 2-pole, time-delay-on-pull-in relay. The time delay is 0.5 second.

**(3) Relay contact logic.**

**(a) Contacts A.** Contacts A (pins C, F, and B) are not used.

**(b) Contacts B.** Contacts B (pins H, D, and G) close after 0.5 second and apply voltage to the inboard stores jettison circuits.

**x. 21K6 - Wing Stores Disable Relay.**

**(1) Purpose.** To disable rocket fire when the TOW missile is fired.

**(2) Function.** This relay prevents rocket firing from the time the left-hand grip TRIGGER is pressed until after the TOW wire is cut. This is a 10-amp, 2-pole, socket-mounted relay.

**(3) Relay contact logic.**

**(a) Contacts A.** Contacts A are not used.

**(b) Contacts B.** Contacts B when energized open the circuit to the pilot WING ARM FIRE switch.

**y. 21K7 - Turret Interrupt Relay.**

**(1) Purpose.** To interrupt turret fire when rockets are fired.

**(2) Function.** This relay opens the trigger circuit to the turret when rockets are fired and keeps it open for 0.5 second after the WING ARM FIRE switch is

released. This is a 10-amp, 2-pole, time-delay-on-dropout relay. The time delay is 0.5 second.

**(3) Relay contact logic.**

**(a) Contacts A.** Contacts A (pins B, C, and F) are used in the energized position to open the turret trigger circuit.

**(b) Contacts B.** Contacts B (pins D, G, and H) are not used.

**9-414. P TURRET SYSTEM CIRCUITRY**

**9-415. P DESCRIPTION - TURRET SYSTEM CIRCUITRY.**

The M28A3 turret system interfaces, by means of auxiliary equipment, with the M136 helmet sight subsystem (HSS) and the turret control portion of the stabilized telescopic sight unit (TSU) of the M65 TOW missile subsystem. The interconnecting airframe wiring integrates the three subsystem components through the interface control unit (IFCU), electronic interface assembly, and the pilot and gunner armament control panels. For additional information pertaining to the M28A3 turret system, refer to TM 9-1090-203 series maintenance manuals. For additional information pertaining to the M136 helmet sight subsystem, refer to TM 9-1270-212-14. For additional information pertaining to the TSU and M65 TOW missile subsystem, refer to paragraph 9-427 and TM 9-1425-473 series maintenance manuals.

**9 - 4 1 6 . \* FUNCTIONAL TEST - TURRET SYSTEM CIRCUITRY.**

**a. Requirements.**

**(1) Test equipment.**

**(a) Auxiliary power.** Ground power unit (T14).

(b) **Hydraulic.** Hydraulic ground test cart (T11).



**All weapons shall be dry fired. Only dummy ammunition with smooth cases like live ammunition shall be used.**

(2) **Special tools.** Airspeed simulator (T10).

**b. Preparation for Testing.**

(1) **General.** Qualified armament personnel shall be present during following tests.

(2) **Configuration.** For the purpose of this test, the M28A3 turret will be assumed to have a 7.62 mm weapon on right side, 40mm weapon on left side, and 7.62 mm/40 mm ammo drums installed.

**(3) Weapon system preparation.**

(a) Check all system components for proper installation.

(b) Check that 7.62 mm weapon and feeder are properly timed.

(4) **Control switch positions.** Position the following switches as indicated:

**(a) Pilot armament control panel.**

MASTER ARM	OFF
WPN CONT	GUNNER
TURRET	BOTH
HSS RCTL brightness knob	midpoint

**(b) Pilot miscellaneous control panel.**

INBD JETTISON SELECT	OFF
OUTBD JETTISON SELECT	OFF

**(c) Pilot rocker control panel.**

WG ST ARM	OFF
RKT PR SEL	1

**(d) Gunner armament control panel.**

PILOT OVRD	OFF
WING STORES SELECT	OFF

AMMO RSV PERCENT - RIGHT	50
AMMO RSV PERCENT - LEFT	50
TURRET SELECT	BOTH
COMP	OFF
HSS reticle brightness knob	midpoint

TURRET DEPR LIMIT	DEPR LIMIT
RANGE	500

**(e) TOW control panel.**

MODE SELECT	OFF
-------------	-----

(5) **Electrical power.** Check that the aircraft battery is connected, then apply 28-volt dc external electrical power. (Refer to paragraph 1-51.)

(6) **Circuit breakers.** Engage the following circuit breakers:

**(a) DC circuit breaker panel.**

GEN FIELD  
DC VM  
CAUT LT  
GEN BUS RESET  
INV MAIN

**(b) Ac circuit breaker panel.**

TOW PWR  
WPM CONT  
WPM FIRE  
HSS  
REF XFMR  
SECU  
TURRET CONT  
RKT PWR

**(c) Ammo Compartment**

XM28 GUN PWR LH  
XM28 GUN PWR RH

(7) **Power switch positions.** Position the following switches as shown:

INV	MAIN
BAT	ON
NON-ESNTL BUS	MANUAL
ELEC PWR/EMER OFF	ELEC PWR



Before proceeding, clear turret area of any obstructions and warn personnel to remain on exterior of safety barrier.



Do not apply hydraulic power to system unless electrical power is applied.

(8) **Hydraulic power.** Apply 1500 ±25 psi hydraulic power.

**c. Testing Procedures.**

(1) **Gunner turret control.** With test personnel in the pilot and gunner positions, connect helmet sight linkages to built-in test (BIT) brackets at the forward support points.

(a) With MASTER ARM switch and PILOT OVRD switch in OFF, check that there is no action or firing of any armament system from any of the action and trigger switches (pilot and gunner cyclic grips and gunner LHG).

(b) Position pilot MASTER ARM switch to STBY. Observe that pilot and gunner green STBY indicators and gunner right 7.62 and left 40 amber indicators are illuminated.

(c) Position HSS BIT switch on gunner control panel to BIT and release. Check that a GO indication appears on HSS indicator.

**NOTE**

**Completion of BIT circuit requires approximately two seconds.**

(d) Remove pilot and gunner linkage from BIT brackets and check for freedom of movement in all directions.

(e) Check that HSS reticle illumination controls on both armament control panels are functioning properly. Turn reticle brightness control knob from OFF to BRT and check for corresponding proper light intensity. Move reticle TEST switch to TEST and check that HSS reticle is still illuminated.

(f) Hold gunner helmet sight line-of-sight (LOS) at 0 degrees elevation and 0 degrees azimuth, press LHG ACTION switch on TSU and slowly rotate LOS downward. The weapon should reach the depression limit at 20 ±5 degrees. The reticle should flash when helmet LOS is out of coincidence with commanded gun line. Release ACTION switch.

(g) Position TURRET DEPR LIMIT switch to OFF.



**If weapons are installed, excessive downward movement of LOS can cause barrels to strike ground.**

(h) Hold gunner helmet sight LOS at 0 degrees elevation and 0 degrees azimuth, press LHG ACTION switch on TSU and slowly rotate LOS downward. Confirm that gun barrels move past the 20 ±5 degrees down position. Release ACTION switch.

(i) Return TURRET DEPR LIMIT switch to DEPR LIMIT.

(j) Press ACTION switch and check that turret traverses in both azimuth and elevation. Movement should be free and in accordance with position commands from the sight.

(k) Move turret through total elevation, depression and azimuth limits. Check that reticles flash while turret is against the azimuth and elevation limits. Check that no binding or interference occurs.

(l) Rotate sight rapidly both in azimuth and elevation. Check that slight reticle flashes momentarily as turret and HSS LOS are out of coincidence.

(m) Release ACTION switch on LHG grip and check that turret returns to stowed (forward) position.

(n) Hold the sight in approximately the 0 degrees azimuth and 0 degrees elevation position and press ACTION switch on LHG grip. Attempt to fire the weapons with gunner and pilot triggers. The weapons should not fire.

(o) Position pilot MASTER ARM switch to ARM. Check that pilot red ARMED, gunner amber

WEAPON MIX, and gunner red ARMED indicators are illuminated and that pilot and gunner green STBY indicators are extinguished.

(p) Position COMP switch on gunner armament control panel to ON.

(q) Hold gunner helmet sight LOS at approximately 0 degrees elevation and 90 degrees azimuth.

(r) Press ACTION switch and move RANGE switch to 1000, then 1500 meters. Check that turret elevation increases with increased range settings. Check that helmet sight reticle does not flash at any range setting. Release ACTION switch and return RANGE switch to 500.

(s) Position gunner TURRET SELECT switch to L. Hold gunner helmet sight LOS at approximately 0 degrees elevation and 90 degrees azimuth.

(t) Press ACTION switch and move RANGE switch to 1000, then 1500 meters. Check that turret elevation increases with increased range selection. Check that helmet sight reticle does not flash at any range setting. Release ACTION switch. Return RANGE switch to 500. Return COMP switch to OFF.

(u) Press LHG ACTION switch and move LHG trigger on gunner TSU to either detent. Check that 40mm weapon fires at  $10 \pm 1$  second burst. Release ACTION switch and press the trigger. The weapon should not fire.

(v) Position gunner TURRET SELECT switch to R. Press LHG ACTION switch and move LHG trigger on TSU to first detent and check that 7.62mm weapon fires a  $6 \pm 1$  second duration burst at the low rate of fire. Release trigger. Press trigger to second detent and check that weapon fires at the higher rate of fire. Release ACTION switch and trigger.

(w) With pilot WPN CONT switch in GUNNER position, press the pilot ACTION switch and trigger. Check that the weapons do not move or fire.



**Before conducting the following steps, verify that all wing stores (launchers, pods, etc.) electrical connections have been disconnected.**

(x) Position pilot WG ST ARM switch to INBD. Check that pilot amber WG ST ARMED light illuminates.

(y) Check that light extinguishes when MASTER ARM switch is in STBY position. Reposition MASTER ARM to ARM.

(z) While firing 7.62mm weapon with gunner LHG, press pilot cyclic stick WING ARM FIRE button. Check that 7.62mm firing is interrupted and that, when WING ARM FIRE button is released, a short time delay occurs before the weapon resumes firing.

(aa) Position gunner TURRET SELECT switch to L and repeat step (z), except fire the 40mm weapon.

(ab) Return gunner TURRET SELECT switch to R and position pilot WG ST ARM switch to OUTBD.

(ac) Repeat steps (Z) and (aa).

(ad) Position pilot WG ST ARM switch to OFF.

(ae) Position gunner TURRET switch to BOTH. Check that 7.62mm weapon fires and that 40mm will not fire.

## (2) Pilot turret control.

(a) Position MASTER ARM switch to STBY.

(b) Position pilot WPN CONT switch to PILOT. Check that blue PILOT IN CONT indicator on gunner control panel illuminates and that amber WEAPON MIX indicator extinguishes. Check that pilot amber WEAPON MIX indicator illuminates.

(c) Press LHG ACTION switch. Check that gunner helmet sight has no control of the turret.

(d) Press gunner cyclic grip ACTION switch. Check that gunner helmet sight has no control of the turret.

(e) Press ACTION switch on pilot cyclic grip and check that turret follows helmet sight LOS in the same manner as that described for gunner in subparagraph (1), steps (f) through (m).

(f) Position MASTER ARM switch to ARM.

(g) Position COMP switch on the gunner control panel to ON.

(h) Position pilot TURRET switch to R.

(i) Hold pilot helmet sight LOS at approximately 0 degrees elevation and 90 degrees azimuth.

(j) Press pilot cyclic stick ACTION switch and move range switch to 1000, then 1500 meters. Check that turret elevation increases with increased range settings. Check that helmet sight reticle does not flash at any range setting. Release ACTION switch and return RANGE switch to 500.

(k) Position pilot TURRET switch to L. Hold pilot helmet sight LOS at approximately 0 degrees elevation and 90 degrees azimuth.

(l) Press ACTION switch and move RANGE switch to 1000, then 1500 meters. Check that turret elevation increases with increased range settings. Check that helmet sight reticle does not flash at any range setting. Release ACTION switch and return RANGE switch to 500. Return COMP switch to OFF.

(m) Position pilot TURRET SELECT switch to BOTH.

(n) Check that only the pilot cyclic stick trigger fires only the 7.62mm weapon; low rate at first detent and high rate at second detent.

(o) Position pilot TURRET switch to L. Check that only pilot cyclic stick trigger fires only the 40mm weapon in either detent.

(p) position pilot TURRET switch to R. Check that only the 7.62mm weapon fires from the pilot cyclic stick trigger.

(q) Position pilot WG STARM switch to INBD. Check that pilot amber WG ST ARMED light illuminates.

(r) While firing 7.62mm weapon from the pilot cyclic grip, press pilot cyclic stick WING ARM FIRE button. Check that 7.62mm firing is interrupted and that, when WING ARM FIRE button is released, a short time delay occurs before the weapon resumes firing.

(s) Position pilot TURRET switch to L and repeat step (r), except fire the 40mm weapon.

(t) Return pilot TURRET switch to R and position pilot WG ST ARM switch to OUTBD.

(u) Repeat steps (r) and (s).

(v) Position pilot WG ST ARM switch to OFF.

**(3) Pilot override by gunner.**

**(a) 7.62mm weapon.**

**1** Position gunner PLT OVRD switch to PLT OVRD.

**2** Check that amber WEAPON MIX indicator on gunner armament control panel illuminates and that blue PILOT INCONT indicator extinguishes. Check that pilot amber WEAPON MIX indicator extinguishes. Check that gunner red ARMED indicator illuminates.

**3** Position gunner TURRET SELECT switch to R or BOTH. Depress gunner cyclic stick ACTION switch. Check that only gunner cyclic stick trigger will fire the 7.62mm weapon and that 40mm weapon will not fire. The gunner helmet sight subsystem (HSS) should control the turret.

**4** Press gunner LHG ACTION switch and trigger. Check that turret does not respond to helmet sight and weapon does not fire.

**5** Press pilot cyclic stick ACTION switch and trigger. Check that pilot helmet sight will not control turret and that weapon does not fire.

**6** Position pilot MASTER ARM switch to OFF and check that both pilot and gunner red ARMED lights remain on. Check that only gunner cyclic stick trigger will fire the 7.62mm weapon.

**7** Position pilot WPN CONT switch to GUNNER. Check that only gunner cyclic stick trigger will fire the 7.62mm weapon.

**(b) 40mm weapon.**

**1** Position gunner TURRET SELECT switch to L. Check that only gunner cyclic stick trigger will fire the 40mm weapon.

**2** Observe that both right and left round counters have moved toward zero.

**(4) Turret airspeed compensation.**

**(a)** Apply air pressure to pitot system to simulate **100 ±5** knots airspeed for steps (b) through (f).

(b) Rotate turret approximately 90 degrees to the right to check airspeed compensator operation.

(c) Position COMP switch on gunner armament control panel to ON. Observe aft turret rotation (indicating airspeed data is being fed to turret positioning circuits).

(d) Position gunner TURRET SELECT switch to R or BOTH.

(e) Check that compensation is greater for 40mm weapon.

(f) Position pilot MASTER ARM to STBY and return gunner PLT OVRD and COMP switches to OFF. Remove air pressure from pitot system.

#### (5) Fixed mode firing.

(a) Position pilot WPN CONT to FIXED.

(b) Press pilot cyclic grip ACTION switch. Check that turret does not follow helmet sight.

(c) Press gunner LHG ACTION switch and

(d) Position MASTER ARM switch to ARM.

(e) Press pilot cyclic grip ACTION switch and trigger. Check that 7.62mm weapon fires but that turret does not follow helmet sight.

**d. Conclusion of Tests.** Upon completion of the preceding armament circuitry tests, accomplish the following:

(1) Return control switches to OFF or normal positions.

(2) Reset (disengage) circuit breakers used.

(3) Turn off and disconnect hydraulic power cart.

(4) Turn off and disconnect 28 Vdc external power source.

### 9-417. TROUBLESHOOTING - TURRET SYSTEM CIRCUITRY.

**a. Airframe Circuitry and Components.** Refer to paragraph F-9 in Appendix F for wiring diagram and

trace malfunctioning circuit loop, using standard electronic troubleshooting procedures, and standard test equipment. Localize malfunctioning components and repair or replace, as required.

**b. Turret System.** Refer to TM 9-1090-203 series maintenance manuals for troubleshooting procedures pertaining to the M28A3 turret system.

**c. Helmet Sight Subsystem.** Refer to TM 9-1270-212-14; for troubleshooting procedures pertaining to the M136 helmet sight subsystem.

**d. Telescopic Sight Unit.** Refer to TM 9-1425-473 series maintenance manuals for troubleshooting procedures pertaining to the telescopic sight unit portion of the M65 TOW missile subsystem.

### 9-418. **P** M136 M136 ELECTRONIC INTERFACE ASSEMBLY.

#### 9-419. **P** DESCRIPTION - M136 ELECTRONIC INTERFACE ASSEMBLY.

The electronic interface assembly is a component of the M136 helmet sight subsystem that provides regulated 28 Vdc power and contains the electronic components necessary for the operation of the HSS. The electronic interface assembly is the point of integration with the interface control unit (IFCU) which interfaces the HSS and TSU sighting systems with the M28A3 turret system. The electronic interface assembly is mounted to the rear cockpit bulkhead (see figure 9-19). The electronic interface assembly contains buffer amplifiers and circuitry required by the linkage resolvers, azimuth and elevation alignment controls and associated circuitry for boresighting each linkage assembly, and the BITE circuits and controls necessary to provide the HSS self-test capability. For additional information and maintenance procedures pertaining to the electronic interface assembly, refer to TM 9-1270-212-14.

#### 9-420. **P** INTERFACE CONTROL UNIT (IFCU).

#### 9-421. **P** DESCRIPTION - INTERFACE CONTROL UNIT (IFCU).

The interface control unit (IFCU) contains the signal switching, buffering and alignment, range compensation, airspeed compensation, and depression limit circuitry necessary to interface the helmet sight subsystem (HSS) and stabilized telescopic sight unit (TSU) with the M28A3 turret

system. The IFCU is located in the right access compartment below the wing (see figure 9-19). When the gunner selects the gun mode in the TOW system, the computing resolver chain contained within the turret system is connected to similar resolvers located in the TSU. Elevation and azimuth commands and a range reference function are then developed in the TSU and are returned to the turret system through the IFCU as positioning signals for the turret assembly. In this manner, as the TSU tracks the target, the turret assembly is commanded to follow the TSU line-of-sight. Operation with either the pilot or gunner helmet sight is accomplished in a like manner. The function of the IFCU is to receive signals from the three sighting units, control panel switching, and airspeed transducer and provide the appropriate circuit response, depending upon the mode activated by the system operator. This interchange of signals is

accomplished in the IFCU with the use of relay logic. Once the sighting unit is selected, turret positioning signals are routed from the sight back through the IFCU integrated circuit buffer amplifiers to the selected sight resolver. The amplifiers ensure that the computing accuracy of the resolver chain is maintained and provide a means of changing outputs for compensation purposes. In addition to the gun mode, an acquisition mode is provided in which either helmet sight positions the TSU. The acquisition mode thus allows either the pilot or the gunner to acquire a target for the TOW missile or turret gun by utilizing the helmet sight. The relay logic in the IFCU also provides a dual mode capability. If the gunner has selected the TOW mode, the pilot has the capability of directing the turret assembly with the helmet sight. In addition, either helmet sight may be directing the turret assembly while the other helmet sight is used

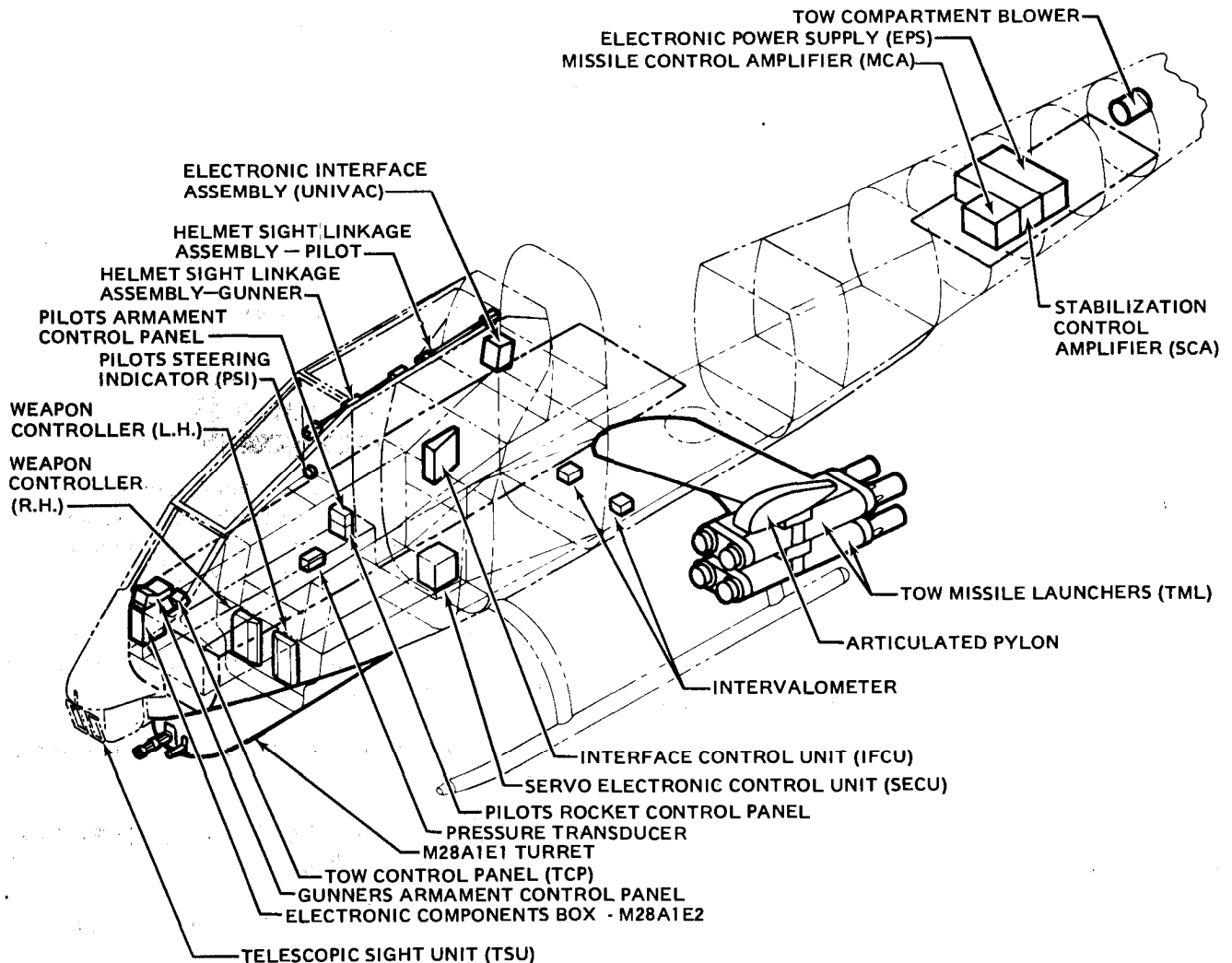

209075-323-1A

Figure 9-19. P Armament Equipment Location (Sheet 1 of 2)



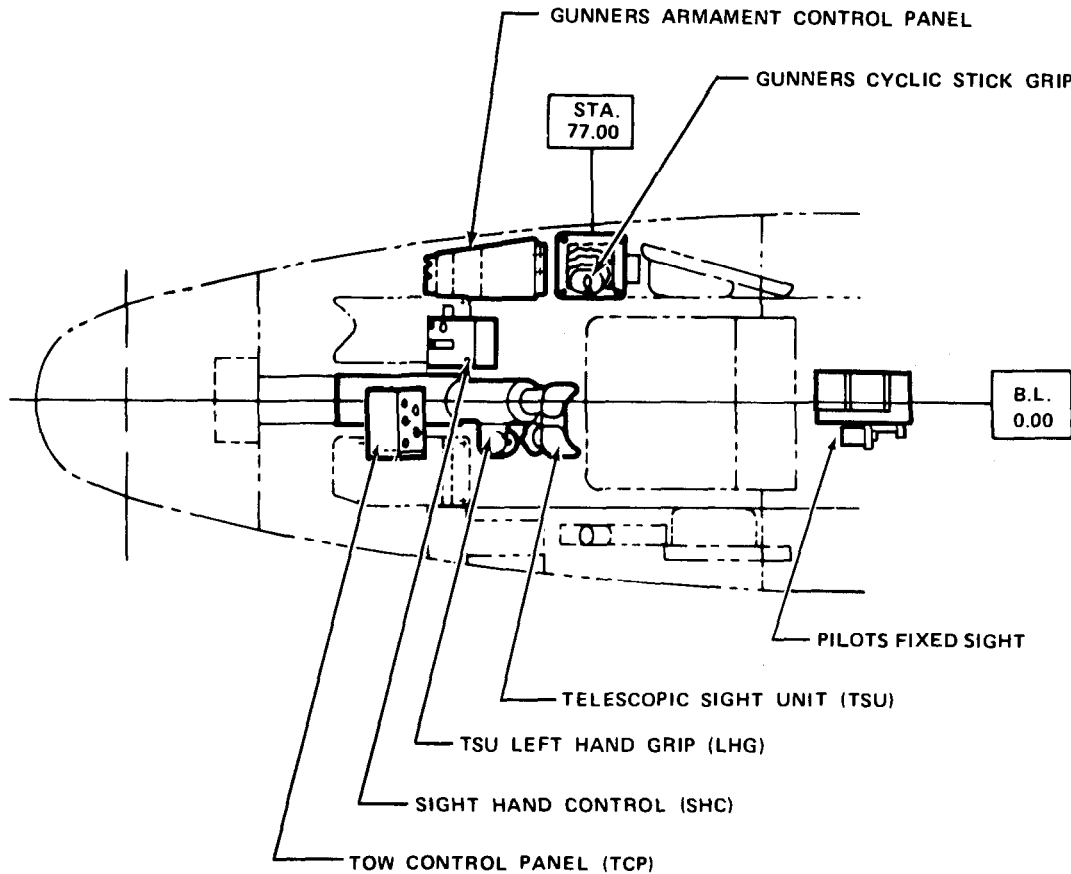

209075-323-2

Figure 9-19. **P** Armament Equipment Location (Sheet 2 of 2)

to acquire a target for the TOW missile or turret gun. Pitch and roll trim resolvers within the IFCU resolve any installation misalignment existing between the TSU and the turret assembly. These resolvers are aligned during system boresighting and then locked in the corrected position. Other IFCU inputs and outputs include airspeed data for turret compensation, helmet sight reticle voltage, and a turret coincidence signal which provides an indication as to turret/sight alignment. The turret depression limit circuitry in the IFCU limits the down elevation of the turret to approximately 25 degrees to prevent damage which could result if gun strikes the ground. Depression limit is activated when gunner positions TURRET DEPR LIMIT switch from OFF to TURRET DEPR LIMIT.

**9-422. P CLEANING - INTERFACE CONTROL UNIT (IFCU).**

a. Remove moisture and loose dirt with a clean, soft cloth.

**WARNING**

Cleaning solvent is flammable and toxic. Provide adequate ventilation. Avoid prolonged breathing of solvent vapors and contact with skin or eyes.

b. Remove grease, fungus, and ground-in dirt with a clean, lint-free cloth dampened with dry cleaning solvent (C112).

c. Remove dirt from electrical connectors with a bristle brush.

**9-423. P INSPECTION - INTERFACE CONTROL UNIT (IFCU).**

a. Inspect IFCU case for cracks or damage.

b. Inspect electrical connectors for broken pins or cracked connector inserts.

c. Inspect IFCU for secure mounting.

**9-424. P REMOVAL - INTERFACE CONTROL UNIT (IFCU).**

a. Ensure all electrical power is OFF.

b. Remove IFCU access panel (right side, below wing).

c. Disconnect three electrical connectors from IFCU. Protect receptacles and plugs with caps or electrical tape (C121),

d. Remove mounting screws and washers, and remove IFCU from wall.

**9-425. P REPAIR - INTERFACE CONTROL UNIT (IFCU).**

a. Repair connectors, and tighten or replace loose or missing mounting screws.

b. Replace IFCU if case is damaged or defective. Evacuate removed IFCU to higher echelon for disposition.

**9-426. P INSTALLATION - INTERFACE CONTROL UNIT (IFCU).**

a. Position IFCU in place on wall and install mounting screws and washers.

b. Remove protective caps or electrical tape from three electrical connectors and install on IFCU.

**9-427. P M65 TOW MISSILE SUBSYSTEM CIRCUITRY.**

**9-428. P DESCRIPTION - M65 TOW MISSILE SUBSYSTEM CIRCUITRY.**

The M65 TOW missile subsystem circuitry provides the capabilities to acquire and track a target, compensate for effects of helicopter motion, launch a TOW missile, and guide the missile to the target. The telescopic sight unit (TSU) portion of the TOW missile subsystem interfaces with the M28A3 turret system circuitry, serving as a flexible sighting unit, and also interfaces with the helmet sight subsystem for use during target acquisition. For description and additional information pertaining to M65 TOW missile subsystem components, refer to TM 55-1520-236-10 and TM 9-1425-473 series maintenance manuals. For maintenance information

and procedures pertaining to M65 TOW missile subsystem components, refer to TM 9-1425-473 series maintenance manuals. For information and maintenance procedures pertaining to the interface control unit (IFCU), refer to paragraph 9-420.

**9-429. P FUNCTIONAL TEST - M65 TOW MISSILE SUBSYSTEM CIRCUITRY.**

a. Requirements.

(1) Test equipment.

(a) Auxiliary power. Ground power unit (T14).

(b) Hydraulic. Hydraulic ground test cart (T11).

(2) Special tools. TOW simulator evaluation missile (TSEM) (T70).

b. Preparation for Testing.

(1) General. Qualified armament personnel shall be present during following tests.

(2) Configuration. For the purpose of this test, the M28A3 turret will be assumed to have a 7.62mm weapon on the right side, a 40mm weapon on the left side, and 7,62mm/40mm ammo drums installed.

**NOTE**

**For functional test of M65 TOW missile launcher system refer to TM 9-1425-473 series maintenance manuals.**

(3) Weapon system preparation.

(a) Check all systems components for proper installation.

(b) Verify that launchers are properly connected, four launchers are installed, and TSEM is installed in No. 1 missile position. (See figure 9-20.)

(c) Open (off) all circuit breakers.

(4) Control switch positions. Position the following switches as indicated:

(a) Pilot armament control panel.

MASTER ARM	OFF
WPN CONT	GUNNER
TURRET	RIGHT

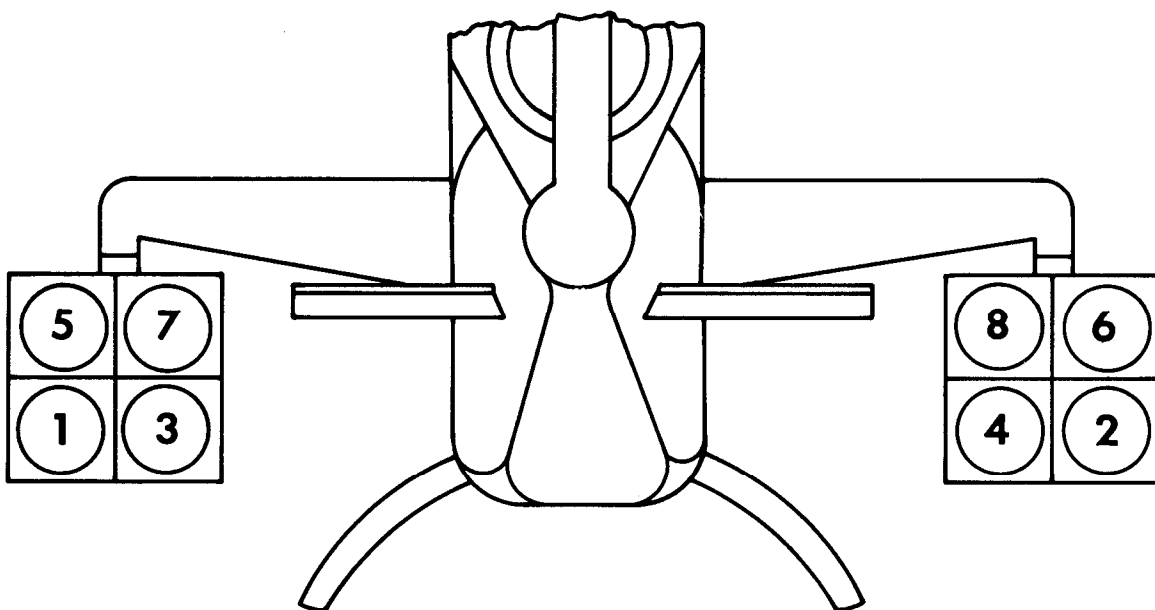

VIEW LOOKING FORWARD

209075-150

Figure 9-20. **P** TOW Missile Launcher Positions

**(b) Pilot rocket control panel.**

WG ST ARM OFF

**(c) Gunner armament control panel.**

WING STORES SELECT OFF  
 TURRET DEPR LIMIT DEPR LIMIT  
 PLT OVRD OFF  
 TURRET SELECT BOTH  
 COMP ON  
 RANGE 500  
 AMMO RSV PERCENT-RIGHT 50  
 AMMO RSV PERCENT-LEFT 50

**(d) Tow control panel (TCP).**

MODE SELECT OFF  
 CAMERA OFF  
 MISSILE SELECT 1  
 EXPOSURE BRT

**(e) Sight hand control (SHC).**

STOW/TRK/ACQ STOW

**(f) Telescopic sight unit (TSU).**

FILTER SELECT LEVER CLEAR

**(5) Electrical power.** Check that aircraft battery is connected, then apply 28-volt dc external electrical power.

**(6) Circuit breakers.** Engage the following circuit breakers:

**(a) DC circuit breaker panel.**

GEN FIELD  
 DC VOLTMETER  
 CAUTION LTS  
 GEN BUS RESET  
 INV MAIN

**(b) Ac circuit breaker panel.**

TOW PWR  
 WPN CONT  
 WPN FIRE  
 HSS  
 REF XFMR  
 SECU PWR  
 TURRET CONT  
 RKT PWR

**(c) Ammo compartment.**

XM28 GUN PWR LH  
 XM28 GUN PWR RH

(7) Power switch positions. Position the following switches as shown:

INVERTERS	MAIN
BATTERY	ON
NON-ESS BUS	MANUAL
ELEC PWR/EMER OFF	ELEC PWR



Before proceeding, clear turret area of any obstructions and warn personnel to remain on exterior of safety barrier.



To ensure immediate control of the system, do not apply hydraulic power to system unless electrical power is applied.

(8) Hydraulic power. Apply 1500 ±25 psi hydraulic power to system No. 2.

(9) Special test equipment. Position the following test equipment switches or controls as indicated:

TOW system evaluator missile (TSEM).

POWER	OFF
FUNCTION	LAMP TEST

**c. Testing Procedures.**

(1) Initial system tests. Perform the following steps for initial system tests:

**NOTE**

For this test, one technician will be required in the gunner position, one technician in the pilot position, and one technician outside the helicopter.

(a) Position pilot MASTER ARM switch to STBY and WPN CONT to GUNNER.

(b) Position TCP MODE SELECT switch to TSU/GUN.

(c) Verify that system status indicator on TCP moves from OFF to TEST after approximately 10 seconds.

(d) Verify that within 140 seconds after TCP system status indicator reads TEST in step (c), the TCP system status indicator moves to PWR ON.

(e) Verify that all BIT indicators on TCP are IN “go” condition (black on black).

(f) Move HI/LO MAG switch on LHG to LO MAG.

(g) Move STOW/TRK/CQ switch to TRK. Observe that TSU turret follows inputs from SHC transducer stick and that status flag in TSU shows GUNS. Verify that gun does not follow the sight.

(h) Position TURRET DEPR LIMIT switch to OFF.

(i) Press ACTION switch on LHG. Observe that turret weapon follows TSU turret when moved through the limits with SHC transducer stick. Observe that GUNS flag in TSU sight flashes when at the limit stops of the turret weapon.

(j) Release ACTION switch. Observe that turret weapon returns to STOW.

(k) Move LOS of TSU to approximately 0 degrees azimuth and elevation and press LHG ACTION switch and trigger. Observe that turret weapon will not fire.

(l) Release ACTION switch. Position pilot MASTER ARM switch to ARM.

(m) Move LOS on TSU to approximately 0 degrees azimuth and elevation and press LHG ACTION switch and trigger. Observe that turret weapon fires.

(n) Release ACTION switch and position MASTER ARM switch on pilot armament control panel to STBY.

(o) Return STOW/TRK/ACQ switch to STOW.

(p) Return TURRET DEPR LIMIT switch to DEPR LIMIT.

(2) Telescopic sight controls. Perform the following steps for initial system turn-on:

(a) Position MODE SELECT switch on TOW control panel (TCP) to STBY TOW. Verify that TCP system status indicator remains at PWR ON.

(b) Position STOW/TRK/ACQ switch to TRK and press LHG ACTION switch. Observe that turret weapon will not follow inputs from SHC transducer stick.

(c) Release LHG ACTION switch and return STOW/TRK/ACQ switch to STOW.

(d) Position TCP MODE SELECT switch from STBY TOW to ARMED MAN. Verify that **TCP system status indicator remains at PWR ON.**

(e) Position MASTER ARM switch on pilot armament control panel from STBY to ARM to STBY. Verify that system status indicator on TCP moves from PWR ON to ARMD to PWR ON during this sequence.

(f) Position WPN CONT switch on pilot armament control panel to PLT.

(g) Position MASTER ARM switch from STBY to ARM to STBY. Verify that system status indicator on TCP remains at PWR ON during this sequence.

(h) Position WPN CONT switch on pilot armament control panel to FIXED and repeat step (g).

(i) Return WPN CONT switch to GUNNER.

(j) Position STOW/TRK/ACQ switch on SHC to TRK and return to STOW. Verify that system status indicator remains in PWR ON position during this sequence.

NOTE

**Steps (k), (l), (m), and (n) should be done in rapid succession in order to maintain the TEST indication. Read these steps before their initiation.**

(k) Press and hold BIT pushbutton on TCP. Verify that ATTACK, RDY, and GUNS flags are visible in TSU eyepiece. Verify that ascend and descend pointers and ATTACK, RDY, and FIRE flags are visible on pilot steering indicator. Release BIT SWITCH after verifying the above and check that system status indicator on TCP reads TEST.

(l) Position TCP MODE SELECT switch from ARMED MAN to OFF to ARMED MAN in less than 5 seconds. Verify that system status indicator on TCP moves from TEST to OFF to TEST. There should be no

10-second delay from OFF to TEST on the TCP system status indicator.

(m) With system status indicator reading TEST from step (k), position STOW/TRK/ACQ switch on sight hand control to TRK and return it to STOW. Verify that system status indicator cycles from TEST to PWR ON to TEST during this sequence.

(n) With system status indicator reading TEST from step (l), position MASTER ARM switch on pilot armament control panel from STBY to ARM to OFF. Verify that system status indicator on TCP moves from TEST to ARMD to OFF during this sequence.

(o) Position pilot MASTER ARM switch to ARM, the STOW/TRK/ACQ switch on the SHC to TRK and position TCP MODE SELECT switch to STBY TOW.

(p) Position TSU optics to HI MAG using HI/LO MAG switch on TSU LHG. Observe that TSU is now in the HI MAG mode.

(q) While holding ACTION switch, use SHC stick to drive TSU from stop to stop horizontally and vertically. Verify that TSU can be driven stop to stop horizontally in less than 50 seconds and vertically in less than 30 seconds.

(r) Position TSU optics to LO MAG using HI/LO MAG switch on TSU LHG.

(s) Use SHC stick to drive TSU to stop, horizontally and vertically. Verify that TSU can be driven from stop to stop horizontally in less than 3 seconds and vertically in less than 2 seconds. Release ACTION switch.

(t) Position TSU OPTICS to HI MAG using the HI/LO MAG switch and position TCP MODE SELECT switch to TSU/GUN.

(u) Use SHC stick to drive TSU from stop to stop horizontally and vertically. Verify that TSU can be driven stop to stop horizontally in 8 seconds and vertically in 4 seconds.

(v) Return STOW/TRK/ACQ switch to STOW.

(3) Helmet sight tracking.

(a) Position MASTER ARM switch on pilot panel to STBY.

**(b)** Connect helmet sight linkages to BUILT-IN TEST (BIT) brackets.

**(c)** Position HSS BIT switch on gunner control panel to BIT and release. Check that GO indication appears on HSS test indicator.

**NOTE**

**Completion of BIT circuit requires approximately two seconds.**

**(d)** Connect pilot and gunner linkages to respective helmets and check for freedom of movement in all directions. Adjust helmet sight reticle on helmet until full reticle pattern can be seen.

**(e)** Position STOW/TRK/ACQ switch to TRK. Press and hold PHS ACQ and check that gunner helmet sight reticle retracts automatically. Check that TSU does follow pilot helmet sight as it is aimed to left, right, up, and down. Release PHS ACQ switch.

**(f)** If installed, return gunner helmet sight reticle to down position.

**(g)** Hold STOW/TRK/ACQ switch in ACQ position. Verify that TSU follows gunner helmet sight as it is aimed to left, right, up, and down. Release STOW/TRK/ACQ switch and check that gunner helmet sight reticle retracts.

**(h)** Position STOW/TRK/ACQ switch to STOW.

**(4)** Pilot steering indicator commands and constraints test. Pilot steering commands on the PSI are a function of TSU AZ and EL gimbal angles. Azimuth PSI steering is biased plus 0.75 degree right for left missiles and minus 0.75 degree left for right missiles. Logic prevents prefiring a TOW missile until LOS rate, gimbal angle, attack logic, launcher position status, and roll constraint requirements are satisfied.

**(a)** Position pilot MASTER ARM switch to ARM.

**(b)** Position TCP MODE SELECT switch to ARMED MAN.

**(c)** Position SHC STOW/TRK/ACQ switch to TRK and HI/LO MAG switch to HI. Select missile number 1.

**(d)** Press LHG ACTION switch.

**(e)** Using SHC, adjust TSU position for azimuth and elevation LOS to be zero.

**(f)** Verify PSI azimuth needle is approximately one-third from center to right when AZ and EL LOS is zero.

**(g)** Select missile number 2.

**(h)** Adjust TSU position for azimuth and elevation LOS to be zero and depress LHG ACTION switch.

**(i)** Verify PSI azimuth needle is approximately one-third from center to the left when the AZ and EL LOS is zero.

**(j)** Move TSU LOS through azimuth and elevation; observe that PSI indicates the movement of TSU LOS.

**(k)** Release LHG ACTION switch.

**(l)** Return STOW/TRK/ACQ switch to STOW.

**(5)** Launcher/TSU alignment and slaving test.

**(a)** Apply hydraulic power to the helicopter. Position TCP MODE SELECT switch to ARMED MAN and MASTER ARM switch to ARM on pilot armament control panel. Position TSU HI/LO MAG switch to HI.

**(b)** Select missile number 1 on TCP. Verify that missile status indicator on TCP for missile number 1 reads MSL.

**(c)** Set STOW/TRK/ACQ switch on SHC to TRK and track TSU to 0 degrees azimuth and 0 degrees elevation.

**(d)** Press and hold ACTION switch on LHG. Verify that left launcher is slaving to TSU LOS in elevation.

**(e)** Drive TSU up slowly in elevation until elevation needle on PSI falls outside the inner rectangle. Verify that PSI RDY flag disappears.

**(f)** Recenter elevation needle and verify reappearance of RDY flag. Drive TSU down until elevation needle falls below the inner rectangle and verify that RDY flag disappears.

(g) Press and hold ACTION switch on LHG and drive TSU with the SHC stick vertically from stop-to-stop. Verify that right launcher does not move and that left launcher follows vertical motion of TSU within limits of the launchers mechanical stops.

(h) With TSU at the lower stop, release LHG ACTION switch and verify that after a short delay (0.5 second), the launcher moves back to its stowed position.

(i) Select missile number 2 and repeat steps (a) through (h), verifying the action of right launcher.

**(6) Armament control tests.** Operation during preparation for launch and guidance of a missile shall be verified as follows:

**(a) Pilot turret control and firing while in TOW mode.**

**1** Position WPN CONT switch on pilot armament control panel to PILOT and MASTER ARM switch to ARM.

**2** With MODE SELECT switch on TCP in any of the TOW modes (STBY TOW, ARMED MAN, or ARMED AUTO) and STOW/TRK/ACQ switch on SHC in either TRK or STOW, check that pilot amber WEAPON MIX indicators and gunner blue PILOT INCONT indicator are illuminated and that pilot can fire the selected turret weapons with his helmet sight.

**3** Position WPN CONT switch to GUNNER.

**4** With MODE SELECT switch on TCP in any of the TOW modes (STBY TOW, ARMED MAN, or ARMED AUTO) and STOW/TRK/ACQ switch on the SHC in either TRK or STOW, check that pilot amber WEAPON MIX indicators are illuminated and that pilot can fire the selected turret weapons with his helmet sight.

**(b) TSEM operating procedure.** Installation and operation of the TSEM shall be as follows:

**1** After loading TSEM into launcher and lowering arming lever, position POWER switch to ON. Check that POWER light and SHEAR PIN light illuminate.

**2** Position SELF TEST switch to AUTO and press RESET button.

**3** When TSEM is fired in a normal sequence, the following will be observed on rear panel of TSEM:

**a** The START and WIRE SIGNAL AMPL lights illuminate simultaneously, then PREFIRE and -12 lights will illuminate in sequence.

**b** The YAW, PITCH, FIRE, MSL GONE, and ZERO lights will illuminate in sequence.

**c** The WIRE CUT and SQUIB DISC lights will illuminate and WIRE SIGNAL AMPL light extinguishes.

**d** The previously mentioned lights will remain illuminated until RESET button is pressed. Exception: the SHEAR PIN light will remain illuminated until launcher arming lever is raised.

#### NOTE

**In first simulated firing following TMS turn on, or following a BIT sequence, the PITCH and YAW balance lights may not illuminate. This should not be interpreted as an abnormal firing sequence unless the PITCH and YAW lights fail to illuminate on successive firings.**

**4** At end of test, or when use of TSEM is not called for in a test, or when TSEM is to be down loaded, position POWER switch to OFF. (An unpowered TSEM loaded into a launcher will not affect outcome of tests not requiring the TSEM.)

**(c) Manual missile selection and firing.**

#### NOTE

**Shear pin depression limits must be within tolerance for the launcher to be acceptable for firing. Both pods of all launchers must be verified. To avoid a double effort, check upper outboard position last.**

**1** Move launcher armament control handle to up position.

**2** Turn TSEM to ON and press reset button.

**3** Connect TSEM power cable to TSEM and to DC power connector located in the ammunition bay.

4 Position TSEM mode select switch to AUTO and power switch to ON.

5 Press TSEM RESET switch and verify that power lamp is illuminated.

6 Rotate mode select switch to LAMP TEST and verify that all TSEM lamps illuminate.

7 Rotate mode select switch to SP "GO" and verify that shear pin light illuminates.

8 Rotate launcher armament control handle to ARMED position and secure it with the captive locking pin. Verify that shear pin light goes out.

9 Rotate TSEM mode select switch to SP "GO" and verify that shear pin lights illuminate. If shear pin light does not illuminate, this launcher position should not be used until readjustment and verification of shear pin depression is accomplished.

10 Push RESET button.

11 Position MASTER ARM switch on pilot armament control panel to ARM.

12 Position MODE SELECT switch on TCP to ARMED MAN. Verify that MISSILE SELECT switch is on missile position No. 1.

13 Verify that missile status indicator on TCP for missile No. 1 indicates MSL.

14 Set STOW/TRK/ACQ switch on SHC to TRK.

15 Set HI/LO MAG switch on LHG to HI.

16 Verify the appearance of ATTK flag in the eyepiece of TSU and on PSI.

#### NOTE

**Within constraint limitations means that elevation and azimuth needles are within inner rectangle and ascend and descend pointers are not visible.**

17 While observing the PSI, maintain maneuver indicators within constraint limitations using SHC tracking stick. Verify that RDY flags are visible on PSI and in eyepiece of TSU.

18 Position TSEM mode select switch to MSL GONE. Verify that RDY flags disappear on PSI and in eyepiece of TSU. Position TSEM mode select switch to AUTO.

#### NOTE

**The ACTION and trigger switch on pilot cyclic grip will be depressed and held through steps 19 through 21. Read all of these steps before depression of the trigger.**

19 Hold pilot helmet sight at 0 degree elevation and 0 degree azimuth and press pilot cyclic stick ACTION and trigger switch. Verify that 7.62mm weapon fires.

20 Press trigger and ACTION switch on LHG. Verify that 7.62mm weapon firing is interrupted.

21 Verify that 7.62mm weapon resumes firing after a time delay of **2.8 TO 3.2** seconds. Release pilot cyclic grip trigger and ACTION switch.

22 Verify the appearance of FIRE flag on PSI. The FIRE flag will disappear at completion of firing sequence, approximately 23 seconds.

23 Using TSEM, verify that proper firing sequence takes place. Lights on TSEM will show proper sequence according to subparagraph (b)3 above.

24 Verify that indicator for missile No. 1 on TCP switches from MSL to barber pole pattern.

25 When FIRE flag disappears, press RESET button on TSEM and verify that indicator for missile No. 1 on TCP again indicates MSL.

26 Press and hold ACTION switch on LHG and drive TSU LOS out of constraints in elevation. Pull trigger to confirm missile will not fire.

27 Press CONST OVRD switch on SHC. Verify the appearance of ATTK flag in eyepiece of TSU and on PSI RDY flag should not appear.

28 Momentarily press trigger on LHG. The ACTION switch may be released with the trigger switch.



**29** Reset TSEM and with TSU LOS in constraints, pull ACTION switch and trigger switch on LHG. Push gunner wire cut switch and observe wire cut indicator on TSEM.

**30** Repeat step 29 using pilot wire cut button.

**31** Remove TSEM from missile position No. 1, cycle (install) TSEM through remaining missile positions, and repeat steps 3 through 31 for each position selected.

**(d) Automatic selection and firing.**

**1** Install TSEM in missile position No. 1.

**2** Set mode select switch on TSEM to AUTO.

**3** Set MASTER ARM switch on pilot armament control panel to ARM. Set MODE SELECT switch on TCP to ARMED AUTO.

**4** Set STOW/TRK/ACQ switch on SHC to TRK.

**5** Set HI/LO MAG select switch on LHG to HI.

**6** Depress LHG ACTION switch and, by observing the PSI, maintain indications within maneuver constraints.

**7** Momentarily press trigger on LHG. Note the completion of firing sequence by observing a loss of FIRE flag on the PSI. Verify that TSEM firing sequence is in accordance with subparagraph (b) 3 above.

**8** Return STOW/TRK/ACQ switch to STOW.

**9** Check that MISSILE SELECT switch on TCP has automatically selected missile No. 2 or the next available missile. Check pilot L-R TOW indicator.

**10** Repeat steps 5 through 9 for all remaining missile positions. Verify that PSI and TCP indications are normal and verify TSEM firing sequence.

**11** For missile position No. 8, set TCP CAMERA switch to AUTO. Verify that camera operations (if available) start when the LHG trigger is

pressed and stop with the loss of fire flag indication on the PSI.

**12** Position gunner PLT OVRD switch to PLT OVRD. Observe that TCP system status indicator moves to OFF.

**13** Turn TSEM off.

**14** Place pilot MASTER ARM to OFF, PLT OVRD to OFF, and TCP MODE SELECT switch to OFF.

**15** Turn CAMERA (if available) switch to OFF.

**d. Conclusion of Tests.** Upon completion of the preceding tests, de-energize and disconnect auxiliary power unit and hydraulic ground test cart. Remove TSEM from launcher.

**9-430. ~ TROUBLESHOOTING - M65 TOW MISSILE SUBSYSTEM CIRCUITRY.**

**a. Airframe Circuitry and Components.** Refer to paragraph F-9 in Appendix F for wiring diagram and trace malfunctioning circuit loop, using standard electronic troubleshooting procedures and standard test equipment. Localize malfunctioning components and repair or replace, as required.

**b. M65 TOW Missile Subsystem.** Troubleshooting of the M65 TOW missile subsystem is accomplished during BIT (built-in test) procedures and also by use of Test Set, Guided Missile System (TSGMS). Refer to TM 9-1425-473 series maintenance manuals for troubleshooting procedures.

**9-431. P SERVO ELECTRONIC CONTROL UNIT (SECU).**

**9-432. P DESCRIPTION - SERVO ELECTRONIC CONTROL UNIT (SECU).**

The servo electronic control unit (SECU) provides regulated power and contains signal switching, servo amplifier, logic, and buffering circuitry necessary to align the pitch angle of the TOW missile launchers with the pitch angle of the line-of-sight (LOS) of the telescopic sight unit (TSU). Slaving of the two pitch angles ensures that the TOW missile will reliably enter the field of view of the infrared receiver of the TSU. The TOW missile can be guided to target only if the initial launch thrust positions the missile within this field of view. During the attack mode, when the

gunner selects a missile for firing, the launcher containing the selected missile is activated, Upon activation, the SECU initial command drives the launcher up. Angular position signals from the TSU resolver are routed to the SECU, processed through buffer amplifier stages, then applied to the respective launcher resolver. The launcher resolver output provides position feedback to the servo amplifier loop, and the accelerometer provides launcher acceleration feedback to the servo amplifier loop, The servo amplifier output to the hydraulic actuator servo coil allows the hydraulic actuator to change the pitch angle of the activated launcher when hydraulic pressure is provided to the actuator. The SECU also has a detector circuit which decreases the servo amplifier gain when the launcher approaches the mechanical elevation stop at either extreme, Hydraulic pressure is applied to the activated launcher through the hydraulic solenoid valve and the launcher pitches from stow position to the correct pitch angle relative to the TSU LOS, When fired, the missile is launched into the field of view of the infrared receiver, and wire transmitted command signals from the M65 guidance and command functional group steers the missile along the TSU LOS. After launch, the SECU activate signal ceases and the launcher is returned to stow position. The hydraulic solenoid is turned off after a **P** delay of  $1.50 \pm 0.75$  seconds, The SECU is located just aft of the ammunition compartment (see figure 9-19).

**9-433. P CLEANING - SERVO ELECTRONIC CONTROL UNIT (SECU).**

- a. Remove moisture and loose dirt with a clean, soft cloth.



**Cleaning solvent is flammable and toxic. Provide adequate ventilation, Avoid prolonged breathing of solvent vapors and contact with skin or eyes.**

- b. Remove grease, fungus, and ground-in dirt with a clean, lint-free cloth dampened with dry cleaning solvent (C112).
- c. Remove dirt from electrical connectors with a bristle brush.

**9-434. P INSPECTION - SERVO ELECTRONIC CONTROL UNIT (SECU).**

- a. Inspect SECU case for cracks or dents.
- b. Inspect SECU for secure mounting.
- c. Inspect electrical connectors for broken pins or cracked inserts.
- d. Inspect printed wiring assemblies for crocked, broken, loose or missing hardware and components; burned components and wiring; cracked, chipped, or broken wiring board.

**9-435. P REMOVAL - SERVO ELECTRONIC CONTROL UNIT (SECU).**

- a. Ensure all electrical power is OFF.
- b. Open left ammo compartment door just forward of wing.
- c. Remove access panel on aft ammo compartment bulkhead.
- d. Disconnect electrical connectors from SECU. Protect receptacles and plugs with caps or electrical tape (C121).
- e. Remove mounting screws and washers securing SECU to structure and remove SECU.
- f. Loosen two screw assemblies on front of SECU. Open door assembly and slide printed wiring assemblies out, if required.

**9-436. P REPAIR SERVO ELECTRONIC CONTROL UNIT (SECU).**

- a. Repair connectors, and tighten or replace loose or missing mounting screws.
- b. Replace SECU if case is damaged or defective, Evacuate removed SECU to higher echelon for disposition.
- c. Replace printed wiring assemblies as required.

**9-437. P INSTALLATION - SERVO  
ELECTRONIC CONTROL UNIT (SECU).**

a. Position SECU in place and secure with mounting screws and washers.

b. Remove protective caps or electrical tape from connectors and connect to respective receptacles on SECU.

c. Close and secure access panel.

d. Close left ammo compartment door.

e. Install printed wiring assembly in SECU case.  
Close door and fasten two screw assemblies.



**9-438. P WING STORES ARMAMENT SYSTEMS CIRCUITRY.**

**9-439. P DESCRIPTION - WING STORES ARMAMENT CIRCUITRY.**

The wing stores armament systems consist of the rocket launcher circuitry, XM-18 minigun circuitry, and wing stores jettison circuitry. Functions of the wing stores armament systems are as follows:

The rocket launcher circuitry enables the pilot to select and control the release (or firing) of rockets from rocket launchers mounted on any or all of the four wing stations. With the system armed, rockets may be released (or fired) by pressing either the pilot WING ARM FIRE switch or gunner WING ARM FIRE switch (when in PLT OVRD mode).

The XM-18 minigun circuitry enables the pilot or gunner (when in PILOT OVERRIDE mode) to select

and fire either or both XM-18 miniguns mounted on inboard wing stations. With the system armed, either or both miniguns may be fired by depressing either the pilot WING ARM FIRE switch or gunner WING ARM FIRE switch (when in PLT OVRD mode).

The wing stores jettison circuitry enables the pilot to select wing station weapons (inboard or outboard) to be jettisoned in an emergency situation. Selected wing station weapons are jettisoned by depressing the pilot or gunner WING STORES JETTISON switch.

**9-440. P FUNCTIONAL TEST - WING STORES ARMAMENT SYSTEM CIRCUITRY.**

**a. Requirements.** The following functional tests are designed to be performed using a test set such as indicated by figures 9-21 and 9-22, or a suitable equivalent, and a 28 Vdc, 300 ampere auxiliary power unit. Refer to TM 9-1090-203-12 for test of intervalometer.

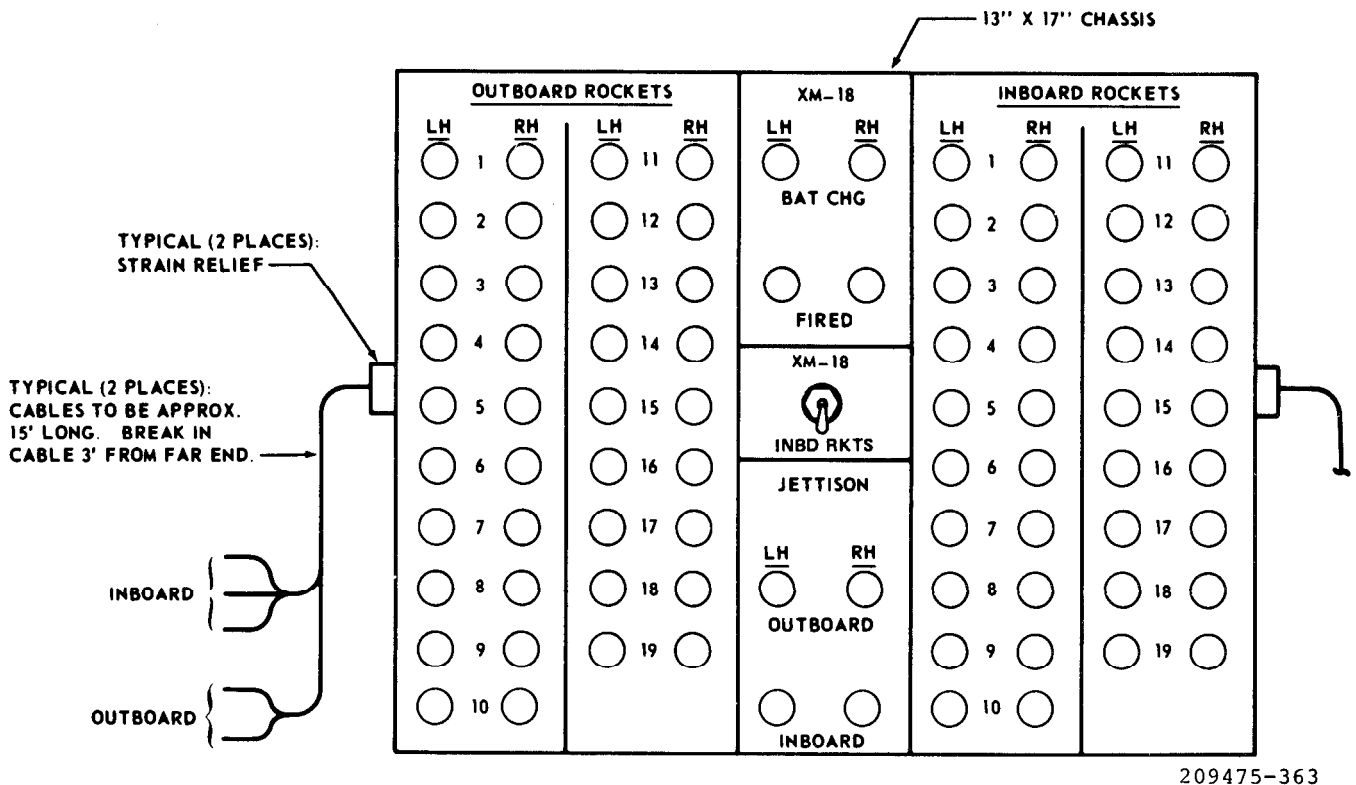

Figure 9-21. P Wing Stores Armament Test Panel

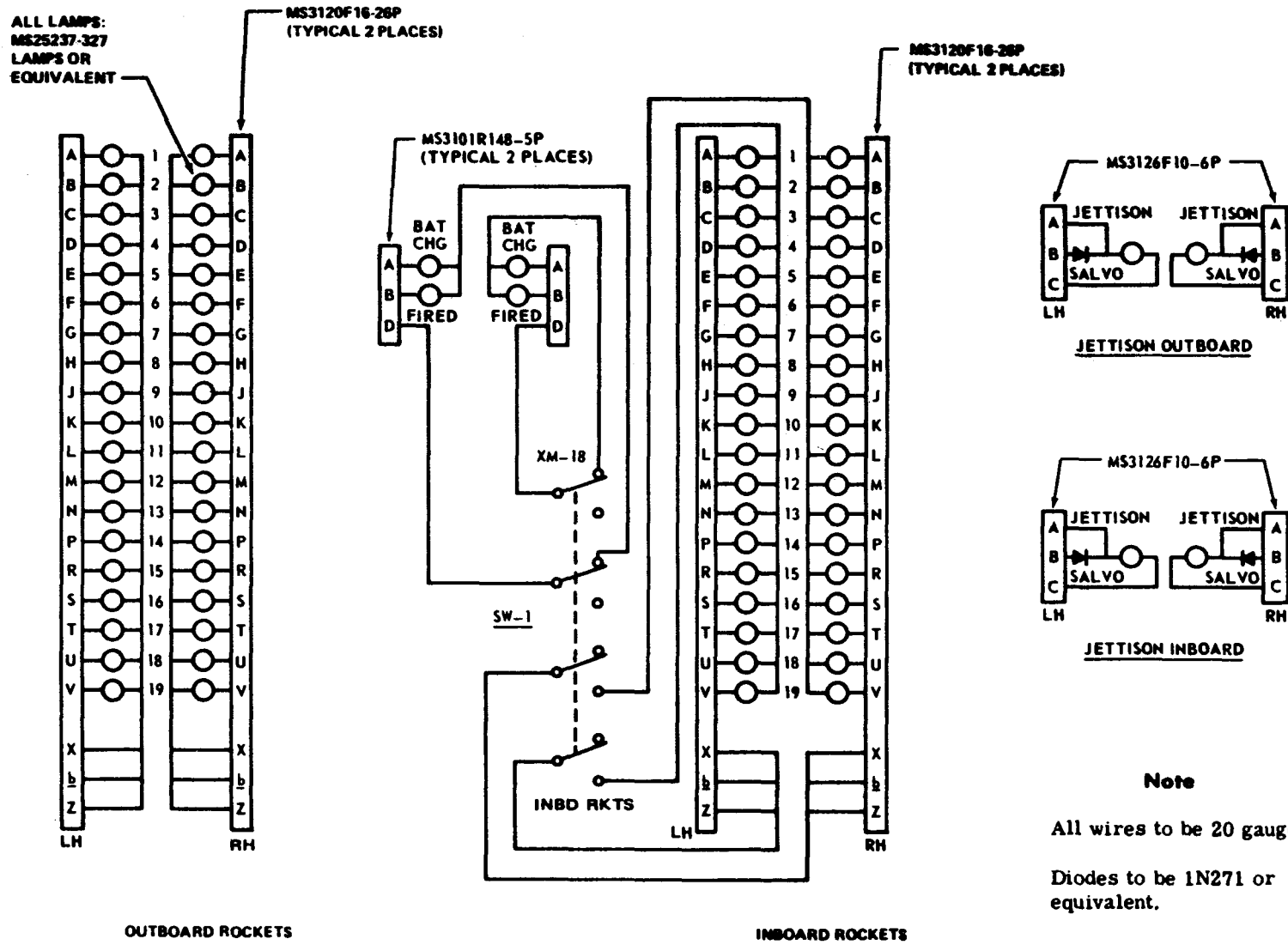

Figure 9-22. P Wing Stores Armament Test Panel Schematic

**WARNING**

**Ensure no live ammunition is present in any of the armament systems. Only dummy ammunition with smooth cases like live ammunition shall be used.**

**b. Preparation for Testing.**

(1) Open all circuit breakers and place all switches to their OFF or normal positions. Connect the appropriate rocket test set cable to each of the four rocket pod connectors (21A4P1, 21A5P1, 21A6P1, and 21A7P1) located at the wing stores disconnect areas in the wings of the helicopter.

(2) Connect the two XM-18 test set cables to connectors (21A8P1 and 21A9P1) at inboard wing stores disconnect area in wings on the helicopter.

(3) Connect test set wing stores jettison cables on test set to respective helicopter receptacles (21SQ1J1, 21SQ2J1, 21SQ3J1 and 21SQ4J1).

(4) Connect a 28 Vdc external power source to helicopter external power receptacle and energize power source.

**NOTE**

**No test set lights shall be illuminated at any time, except as indicated in the following test procedures.**

**c. Rocket Launcher Circuitry Test (Pilot Controlled Firing).**

(1) Place XM-18/ROCKETS switch SW-1 on armament test set to INBD RKTS. Close WPN FIRE and RKT PWR circuit breakers. Position MASTER ARM switch to ARM. Position WG ST ARM switch (21S6) to OUTBD. Place RKT PR SEL switch to position 1. Depress WING ARM FIRE switch on pilot cyclic stick. Check that No. 1 pair of OUTBOARD ROCKET lights on test set illuminate briefly and then extinguish.

(2) Depress WING ARM FIRE switch on pilot cyclic stick again. Check that No. 1 pair of OUTBOARD ROCKET lights on test set do not illuminate, and that No. 2 pair illuminate briefly, and then extinguish.

(3) Release WING ARM FIRE switch. Place RKT PR SEL switch to position 2. Depress and hold WING ARM FIRE switch on pilot cyclic stick. Check that No. 1

and No. 2 pairs of OUTBOARD ROCKET lights do not illuminate, but No. 3 pair, and then No. 4 pair, illuminate briefly, then extinguish.

(4) Release WING ARM FIRE switch. Place RKT PR SEL switch to position 4. Depress and hold WING ARM FIRE switch on pilot cyclic stick. Check that the No. 1, No. 2, No. 3 and No. 4 pairs of OUTBOARD ROCKET lights do not illuminate, but that No. 5, No. 6, No. 7, and No. 8 pairs illuminate briefly in turn, then extinguish, leaving no lights illuminated.

(5) Release WING ARM FIRE switch. Place RKT PR SEL switch to position 7. Depress and hold WING ARM FIRE switch on pilot cyclic stick. Check that the No. 1 through No. 8 pairs of OUTBOARD ROCKET lights do not illuminate, but that No. 9 through No. 15 rocket pair lights illuminate briefly in turn, then extinguish, leaving no lights illuminated.

(6) With RKT PR SEL switch still in position 7, release and depress WING ARM FIRE switch. Check that rocket pair lights No. 1 through No. 15 do not illuminate, but No. 16 through No. 19 rocket pairs illuminate briefly in turn, then extinguish, leaving no lights illuminated.

(7) Open, then close RKT PWR circuit breaker to reset the intervalometer memory. Place RKT PR SEL switch to position 19. Depress and hold WING ARM FIRE switch on pilot cyclic stick. Check that each pair of OUTBOARD ROCKETS lights illuminate briefly and then extinguish, beginning with No. 1 and continuing through No. 19, and that no lights remain illuminated.

(8) Release WING ARM FIRE switch. Open and close RKT PWR circuit breaker to reset intervalometer memory. With RKT PR SEL switch still set to position 19, depress WING ARM FIRE switch on pilot cyclic stick, and hold until 7 to 10 of the light pairs have illuminated briefly in turn, and then extinguished. Release WING ARM FIRE switch. Check that none of the previously illuminated light pairs become illuminated, and that each remaining pair illuminates briefly, and then extinguishes until all rocket pair lights have illuminated briefly and extinguished. No lights shall remain illuminated.

(9) Release WING ARM FIRE switch. Open and close the RKT PWR circuit breaker to reset the intervalometer memory. Place RKT PR SEL switch to position 19. Depress and hold WING ARM FIRE switch on pilot cyclic stick. Check that each pair of OUTBOARD ROCKETS lights illuminate briefly and

then extinguish, beginning with No. 1 and continuing through No. 19, and that no lights remain illuminated.

(10) Release WING ARM FIRE switch. Open and close the RKT PWR circuit breaker to reset the intervalometer memory. Depress and hold, then release WING ARM FIRE switch on gunner cyclic stick. Check that gunner WING ARM FIRE button has no control, and that no light pairs on test set become illuminated.

(11) Repeat steps (1) through (9), except place WG ST ARM switch to INBD position and observe INBOARD ROCKET light pairs instead of OUTBOARD ROCKET light pairs on test set.

(12) Open and close the RKT PWR circuit breaker to reset the intervalometer memory. Set RKT PR SEL switch to position 7. Depress WING ARM FIRE switch on pilot cyclic stick and hold until 7 inboard light pairs have successively illuminated briefly and then extinguished, and no light pairs remain illuminated. Place WG ST ARM switch to OUTBD position, but do not reset intervalometer memory. Depress WING ARM FIRE switch on pilot cyclic stick and hold until 7 outboard light pairs have successively illuminated briefly and then extinguished and no light pairs remain illuminated. Place WG ST ARM switch to INBD position, but do not reset intervalometer memory. Depress and hold WING ARM FIRE switch until 7 additional pairs of inboard rockets lights beginning with No. 8 have illuminated briefly and extinguished. No light pairs shall remain illuminated.

(13) Place WG ST ARM switch to OUTBD. Do not reset the intervalometer memory. Depress and hold the pilot WING ARM FIRE switch. Check the outboard rocket light pairs No. 8 through No. 14 illuminate briefly and then extinguish. No light pairs should remain illuminated.

#### d. Rocket Launcher Circuitry Test (Gunner Controlled Firing).

(1) XM-18/ROCKETS switch, SW-1, on the test set shall remain in INBD RKTS position. Unlock PLT OVRD switch on gunner armament control panel and position it to PLT OVRD. Position MASTER ARM switch to ARM. Repeat all tests in preceding steps c(1) through c(8) and steps c(10) through c(12), except the test described in step c(9), substituting WING STORES SELECT switch for WG ST ARM switch, and WING ARM FIRE switch on gunner cyclic stick **for WING ARM FIRE switch on pilot cyclic stick.**

(2) Repeat test described in preceding step c(9), substituting WING ARM FIRE switch on pilot cyclic stick for WING ARM FIRE switch on gunner cyclic stick. Check that the pilot WING ARM FIRE switch will fire wing stores armament.

(3) Place MASTER ARM switch to the OFF position. Depress WING ARM FIRE switch on gunner cyclic stick. Check for no response on the test set.

#### e. XM-18 Minigun Circuitry Test.

(1) Place XM-18 INBD RKTS switch on test set to XM-18 position. Place gunner PLT OVRD switch to OFF. Place pilot WG ST ARM switch (21S6) to INBD. Close TURRET PWR, RH MINIGUN, and LH MINIGUN circuit breakers. Place MASTER ARM switch to STBY. Check that XM-18 BAT CHG lights on test set illuminate.

(2) Depress WING ARM FIRE switch on pilot cyclic stick. Check that XM-18 FIRED lights on test set do not illuminate.

(3) Place MASTER ARM switch to ARM. Depress and hold pilot WING ARM FIRE switch. Check that XM-18 FIRED lights illuminate.

(4) Release pilot WING ARM FIRE switch. Check that XM-18 FIRED lights extinguish.

(5) Place pilot WG ST ARM switch to OFF. Depress pilot WING ARM FIRE switch. Check XM-18 FIRED lights do not illuminate.

(6) Place PLT OVRD switch to ON. Set gunner WG ST ARM switch to INBD. Depress and hold pilot WING ARM FIRE switch. Check that XM-18 FIRED lights illuminate.

(7) Release gunner WING ARM FIRE switch. Check that XM-18 FIRED lights extinguish.

(8) Place gunner WG ST ARM switch to OFF. Depress gunner WING ARM FIRE switch. Check that XM-18 FIRED lights do not illuminate. Return gunner WG ST ARM switch to INBD.

(9) Depress pilot WING ARM FIRE switch. Check that XM-18 FIRED lights do not illuminate.

(10) Place pilot WG ST ARM switch to INBD. Depress and hold pilot WING ARM FIRE switch. Check that XM-18 FIRED lights illuminate.



(11) Release pilot WING ARM FIRE switch. Check that XM-18 FIRED lights extinguish.



**Ensure cartridges are removed before performing circuitry tests.**

(12) Place MASTER ARM switch to OFF. Depress and hold the pilot WING ARM FIRE switch. Check that XM-18 FIRED lights do not illuminate.

**f. Wing Stores Jettison Circuitry Test.** Open all armament circuit breakers. Ensure that JETTISON SELECT switches (21S4 and 21S5) on pilot miscellaneous panel are in OFF position. Ensure that WING STORES JETTISON switch (21S1) on gunner instrument panel is in the down position and that metal guard is in place over the switch toggle. Close WING STORES JTSN circuit breaker. Check that no JETTISON lights on test set are illuminated and perform checkout procedures in accordance with Table 9-33.

(13) Release WING ARM FIRE switch. Check that XM-18 FIRED lights extinguish.

(14) Place gunner PLT OVRD switch to OFF. Check that neither WING ARM FIRE switch will cause XM-18 FIRED lights to illuminate and that XM-18 BAT CHG lights are extinguished.

**Table 9-33. P Wing Stores Jettison Checklist Chart**

STEP	Pilots OUTBD JETTISON SELECT Switch (21S5)	Pilots INBD JETTISON SELECT Switch (21S4)	Gunners JETTISON SELECT Switch (21S2)	Pilots CLTV JETTISON Switch (21S3)	Gunners CLTV JETTISON Switch (21S1)	Results Test Set Jettison Lights
(a)						No test set jettison lights
(b)	OFF	OFF	BOTH	Depress & Release	OFF	No test set jettison lights
(c)	OFF	OFF	INBD	Depress & Release	OFF	No test set jettison lights
(d)	OFF	OFF	OUTBD	Depress & Release	OFF	No test set jettison lights
(e)	OUTBD	OFF	BOTH	Depress & Release	OFF	Outboard lights illuminate & extinguish approximately 0.5 second later
(f)	OFF	INBD	BOTH	Depress & Release	OFF	Inboard lights illuminate & extinguish approximately 0.5 second later
(g)	OUTBD	INBD	BOTH	Depress & Release	OFF	Outboard and inboard lights illuminate & extinguish approximately 0.5 second later

Table 9-33. **P** Wing Stores Jettison Checklist Chart (Cont)

STEP	Pilots OUTBD JETTISON SELECT Switch (21S5)	Pilots INBD JETTISON SELECT Switch (21S4)	Gunners JETTISON SELECT Switch (21S2)	Pilots CLTV JETTISON Switch (21S3)	Gunners CLTV JETTISON Switch (21S1)	Results Test Set Jettison Lights
(h)	OUTBD	INBD	BOTH	Released	JTSN	No test set jettison lights
(i)	OUTBD	OFF	BOTH	Released	JTSN	No test set jettison lights
(j)	OFF	INBD	BOTH	Released	JTSN	No test set jettison lights
(k)	OFF	OFF	BOTH	Released	OFF	No test set jettison lights
(l)	(1) Close GNR JTSN circuit breaker.					No test set jettison lights
(m)	OFF	OFF	INBD	Released	JTSN	Inboard lights illuminate
(n)	OFF	OFF	OUTBD	Released	JTSN	Outboard lights illuminate
(o)	OFF	OFF	BOTH	Released	JTSN	Outboard & inboard lights illuminate
(p)	Insert jumper wires between pins A & C for both connectors 20P8J01 & 20S8J01					
(q)	OFF	INBD	BOTH	Depress & Release	OFF	Outboard lights illuminate & extinguish approximately 0.5 second later
(r)	OFF	OFF	INBD	Released	JTSN	Same as above, except outboard lights remain illuminated
(s)	Repeat step (n)					
(t)	Open GNRJTSN circuit breaker					
(u)	Repeat steps (b) through (k)					
(v)	Remove jumper wires from connectos 20P8J01 & 20S8J01					

**9-441. P TROUBLESHOOTING - WING STORES ARMAMENT SYSTEMS CIRCUITRY.**

Refer to paragraph F-9 in Appendix F for wiring diagram.

**NOTE**

**In the following troubleshooting procedures it is assumed that power is**

**applied to the main dc and ac buses, and the applicable circuit breakers are closed.**

**a. Troubleshooting - Rocket Launcher Circuitry.** Use Table 9-34 and perform checks as necessary to isolate trouble. In the following table, tripped circuit breakers are omitted from indications of trouble. Such trouble is usually easily detected and corrected. Broken wiring is always a probable cause of circuit malfunction or failure and has not been included.

**NOTE**

**Before you use this table, be sure you have performed all normal operational checks. If you have a malfunction which is not listed in this table, notify the next higher level of maintenance.**

**Table 9-34. P Troubleshooting Rocket Launcher Circuitry**

**CONDITION**

**TEST OR INSPECTION**

**CORRECTIVE ACTION**

1. With MASTER ARM switch positioned to ARM, pilots and gunners amber ARMED indicators illuminated, and WG ST ARM switch in either INBD or OUTBD position, amber wing stores ARMED light is not illuminated.

STEP 1. Check for defective light, wiring and WG ST ARM switch.

**Replace light or switch if defective. Repair any defective wiring (paragraph 9-16).**

STEP 2. Check for defective turret system circuitry.

**Refer to TM 9-1090-203 series maintenance manuals.**

2. With WPNS FIRE and RKT PWR circuit breakers closed, MASTER ARM switch positioned to ARM, WG ST ARM switch in either INBD or OUTBD position, amber wing stores ARMED light illuminated, but rockets do not fire when WING STORES FIRE switch on pilot cyclic stick is pressed.

STEP 1. Check for defective wiring.

**Repair any defective wiring (paragraph 9-16).**

STEP 2. Check for defective WG ST ARM switch.

**If defective, replace WG ST ARM switch (paragraph 9-16).**

Table 9-34. **P** Troubleshooting Rocket Launcher Circuitry (Cont)**CONDITION****TEST OR INSPECTION****CORRECTIVE ACTION**

STEP 3. Check for defective WING ARM FIRE switch on pilot cyclic stick.

**Handle in accordance with instruction pertinent to the cyclic stick (paragraph 11-30).**

STEP 4. Check for defective master arm relay (19K31).

**If defective, replace relay (paragraph 9-16).**

STEP 5. Check for defective intervalometer.

**If defective, replace intervalometer.**

3. With WPNS FIRE and RKT PWR circuit breakers closed, MASTER ARM switch positioned to ARM, WG ST ARM switch in either INBD or OUTBD position, amber wing stores ARMED light illuminated, 19 rockets fire when WING ARM FIRE switch on pilot cyclic stick is pressed, regardless of position of RKT PR SEL switch.

STEP 1. Check for defective RKT PR SEL switch.

**If defective, replace switch (paragraph 9-16).**

**NOTE**

**Open circuit at RKT PR SEL switch fires all 19 rockets.**

4. With WPNS FIRE and RKT PWR circuit breakers closed, MASTER ARM switch positioned to ARM, WG ST ARM switch in either INBD or OUTBD position, amber wing stores ARMED light illuminated, one left wing rocket fires but the right wing rocket does not fire when WING ARM FIRE switch is pressed.

STEP 1. Inspect for defective ground connections to airframe on right wing.

**If defective, repair ground connectors.**

STEP 2. Check for defective wiring.

**If defective, repair wiring.**

STEP 3. Check for defective connector (21J2) or (21P2), (21J4) or (21P4).

**If defective, replace connector (paragraph 9-16).**

STEP 4. Check for defective intervalometer.

**If defective, replace intervalometer.**

5. With WPNS FIRE and RKT PWR circuit breakers closed, MASTER ARM switch positioned to ARM, WG ST ARM switch in either INBD or OUBD position, amber wing stores ARMED light illuminated, the right wing rocket fires but the left wing rocket does not fire when WING ARM FIRE switch is pressed.

Table 9-34. **P** Troubleshooting Rocket Launcher Circuitry (Cont)**CONDTION****TEST OR INSPECTION****CORRECTIVE ACTION**

STEP 1. Inspect for defective ground connections to airframe on left wing.

**If defective, repair ground connections.**

STEP 2. Check for defective wiring.

**If defective, repair wiring.**

STEP 3. Check for defective connector (21J1) or (21P1), (21J3) or (21P3).

**If defective, replace connector (paragraph 9-16).**

STEP 4. Check for defective intervalometer.

**If defective, replace intervalometer.**

6. With WPNS FIRE and RKT PWR circuit breakers closed, MASTER ARM switch positioned to ARM, WG ST ARM switch in either INBD or OUTBD position, amber wing stores ARMED light illuminated, the OUTBD rockets fire normally from both sides but the INBD rockets will not fire when pilot WING ARM FIRE switch is pressed.

STEP 1. Check for defective wiring.

**If defective, repair wiring.**

STEP 2. Check for defective WG ST ARM switch.

**If defective, replace switch (paragraph 9-16).**

7. With WPNS FIRE and RKT PWR circuit breakers closed, MASTER ARM switch positioned to ARM, WG ST ARM switch in either INBD or OUTBD position, amber wing stores ARMED light illuminated, the INBD rockets fire normally from both sides but the OUTBD rockets will not fire when pilot WING ARM FIRE switch is pressed.

STEP 1. Check for defective wiring.

**If defective, repair wiring.**

STEP 2. Check for defective WG ST ARM switch.

**If defective, replace switch (paragraph 9-16).**

8. With WPNS FIRE, RKT PWR, and TURRETPWR circuit breakers closed, PILOT OVRD switch in gunner control panel in PILOT OVRD, WING STORES SELECT switch in either INBD or OUTBD position, rockets will not fire when WING ARM FIRE switch on gunner cyclic stick is pressed.

Table 9-34. **P** Troubleshooting Rocket Launcher Circuitry (Cont)

---

**CONDITION**

**TEST OR INSPECTION**

**CORRECTIVE ACTION**

STEP 1. Check for defective wiring.

**If defective, repair wiring.**

STEP 2. Check for defective WING ARM FIRE switch on gunner cyclic stick.

**Handle in accordance with instructions pertinent to the cyclic stick (paragraph 11-54).**

STEP 3. Check for defective RKT PR SEL switch (See item 3.)

**If defective, replace switch (paragraph 9-16).**

STEP 4. Check for defective RKT PWR circuit breaker.

**If defective, replace circuit breaker (paragraph 9-23).**

STEP 5. Check for defective master arm relay (19K31).

**If defective, replace relay (paragraph 9-16).**

STEP 6. Check for defective connector (21A1J1).

**If defective, replace connector (paragraph 9-16).**

STEP 7. Check for defective intervalometer.

**If defective, replace intervalometer.**

STEP 8. Check for defective turret system circuitry.

**Refer to TM 9-1090-203 series maintenance manuals.**

9. With WPNS FIRE, RKT PWR, and TURRET PWR circuit breakers closed, PILOT OVRD switch in gunner control panel in PILOT OVRD, WING STORES SELECT switch in either INBD or OUTBD position, the OUTBD rockets fire normally from both sides, but INBD rockets do not fire when gunner WING ARM FIRE switch is pressed.

STEP 1. Check for defective wiring.

**If defective, replace wiring.**

STEP 2. Check for defective turret system circuitry.

**Refer to TM 9-1090-203 series maintenance manuals.**

Table 9-34. **P** Troubleshooting Rocket Launcher Circuitry (Cont)

---

**CONDITION****TEST OR INSPECTION****CORRECTIVE ACTION**

10. With WPNS FIRE, RKT PWR, and TURRET PWR circuit breakers closed, PILOT OVRD switch in gunner control panel in PILOT OVRD, WING STORES SELECT switch in either INBD or OUTBD position, the INBD rockets fire normally from both sides, but OUTBD rockets do not fire when gunner WING ARM FIRE switch is pressed.

STEP 1. Check for defective wiring.

**If defective, replace wiring.**

STEP 2. Check for defective turret system circuitry.

**Refer to TM 9-1090-203 series maintenance manuals.**

11. With switches and circuit breakers positioned to fire rockets, either INBD or OUTBD, rockets do not fire, from the pilot cyclic stick, in the correct numbers of pairs as indicated by the setting of the RKT PR SEL switch.

STEP 1. Check for defective wiring.

**If defective, repair wiring.**

STEP 2. Check for defective RKT PR SEL switch, causing 19 pairs to fire.

**If defective, replace switch (paragraph 9-16).**

STEP 3. Check for defective intervalometer.

**If defective, replace intervalometer.**

---

b. Troubleshooting - XM-18 Minigun Circuitry.

checks. If you have a malfunction which is not listed in this table, notify the next higher level of maintenance.

**NOTE**

Before you use this table, be sure you have performed all normal operational

Table 9-35. **P** Troubleshooting XM-18 Minigun Circuitry

---

**CONDITION**

**TEST OR INSPECTION**

**CORRECTIVE ACTION**

1. With WPNS FIRE and both L and R MINIGUN circuit breakers closed, MASTER ARM switch positioned to ARM, WG ST ARM switch in INBD position, XM-18 miniguns do not fire when pilot WING ARM FIRE switch is pressed.

STEP 1. Check for defective wiring.

**If defective, repair wiring.**

STEP 2. Check for defective master arm relay (19K31).

**If defective, replace relay (paragraph 9-16).**

STEP 3. Check for defective WG ST ARM switch.

**If defective, replace switch (paragraph 9-16).**

STEP 4. Check for defective WING ARM FIRE switch on pilot cyclic stick.

**Handle in accordance with instructions pertinent to the cyclic stick (paragraph 11-40).**

2. With WPNS FIRE and both L and R MINIGUN circuit breakers closed, MASTER ARM switch positioned to ARM, WG ST ARM switch in INBD position, one XM-18 minigun fires, but the other does not fire.

STEP 1. Check for defective ground connection to airframe on the side which does not fire.

**If defective, repair ground connection.**

STEP 2. Check for defective wiring.

**If defective, repair wiring.**

STEP 3. Check for defective wing disconnect connector (21JI - 21P1 or 21J2 - 21P2) on the side which does not fire.

**If defective, replace connector (paragraph 9-16).**



Table 9-35. **P** Troubleshooting XM-18 Minigun Circuitry (Cont)**CONDITION****TEST OR INSPECTION****CORRECTIVE ACTION**

STEP 4. Check for defective WING STORES MINIGUN circuit breaker which controls the side that does not fire.

**If defective, replace circuit breaker (paragraph 9-23).**

3. With TURRET PWR circuit breakers and both L and R MINIGUN circuit breakers closed, PILOT OVRD switch positioned to PILOT OVRD, and WING STORES SELECT switch in INBD position, neither XM-18 minigun fires when AING ARM FIRE switch on gunner cyclic stick is pressed.

STEP 1. Check for defective wiring.

**If defective, repair wiring.**

STEP 2. Check for defective TURRET CONT circuit breaker.

**If defective, replace circuit breaker.**

STEP 3. Check for defective WING ARM FIRE switch on gunner cyclic stick.

**Handle in accordance with instructions pertinent to the cyclic stick (paragraph 11-40).**

STEP 4. Check for defective connector (21A9P1), (21A8P1), (21J1 - 21P1), (21J2 - 21P2).

**If defective, replace connector (paragraph 9-16).**

STEP 5. Check for defective turret system circuitry.

**Refer to TM 9-1090-203 series maintenance manuals.**

4. With TURRET CONT circuit breakers and both L and R MINIGUN circuit breakers closed, PILOT OVRD switch positioned to PILOT OVRD, and WING STORES SELECT switch in INBD position, one XM-18 minigun fires, but the other does not fire when gunner WING ARM FIRE switch is pressed.

STEP 1. Check for defective wiring.

**If defective, repair wiring.**

STEP 2. Check for defective TURRET CONT circuit breaker.

**If defective, replace circuit breaker (paragraph 9-23).**

STEP 3. Check for defective WING ARM FIRE switch on gunner cyclic stick.

**Handle in accordance with instructions pertinent to the cyclic stick (paragraph 11-40).**

Table 9-35. **P Troubleshooting** XM-18 Minigun Circuitry (Cont)

---

**CONDITION**

**TEST OR INSPECTION**

**CORRECTIVE ACTION**

STEP 4. Check for defective connector (21A9P1), (21A8P1), (21J1 - 21P1), (21J2 - 21P2).

**If defective, replace connector (paragraph 9-16).**

STEP 5. Check for defective turret system circuitry.

**Refer to TM 9-1090-203 maintenance manuals.**

---

**c. Troubleshooting - Wing Stores Jettison Circuitry.**

**NOTE**

**Before you use this table, be sure you have performed all normal operational checks. If you have a malfunction which is not listed in this table, notify the next higher level of maintenance.**

Table 9-36. **P Troubleshooting** Wing Stores Jettison Circuitry

---

**CONDITION**

**TEST OR INSPECTION**

**CORRECTIVE ACTION**

1. WING STORES JTSN and PLT JTSN circuit breakers are closed. Pilot JETTISON SELECT switches are positioned as required to jettison appropriate wing stores. Gunner JTSN SEL switch is in BOTH position and gunner JETTISON switch is in OFF position. The appropriate (outboard, inboard, or both) wing stores do not jettison when pilot collective JETTISON switch is depressed.

STEP 1. Check for defective wiring.

**Replace or repair wiring.**

STEP 2. Check for defective PLT JTSN or WING STORES JTSN circuit breakers. (21CB1 and/or 21CB2).

**Replace defective circuit breaker(s) (paragraph 9-23).**

Table 9-36. **P** Troubleshooting Wing Stores Jettison Circuitry (Cont)**CONDITON****TEST OR INSPECTION****CORRECTIVE ACTION**

STEP 3. Check for defective pilot collective JETTISON switch (21S3).

**Replace defective switch (paragraph 9-16).**

STEP 4. Check for defective pilot JETTISON SELECT switches (21S4 and/or 21S5).

**Replace defective switch(es) (paragraph 9-16).**

STEP 5. Check for defective or incorrectly installed diodes (21CR3, 21CR4).

**Replace defective diodes (paragraph 9-16).**

STEP 6. Check for defective pilot jettison switch relay (21K3).

**Replace defective relay (paragraph 9-16).**

STEP 7. Check for defective jettison control relay (21K2) or pilot jettison control relay (21K4).

Replace defective relay (paragraph 9-16).

2. With conditions same as condition 1, appropriate wing stores are jettisoned on one side, but not on the other side when pilot collective JETTISON switch is depressed.

STEP 1. Check for defective wiring.

**Replace defective connector (paragraph 9-16).**

STEP 2. Check for defective wing disconnect connectors (21J1/21P1, 21J3/21P3 or 21J2/21P2, 21J4/21P4) on side that does not jettison properly.

**Repair wiring if defective (paragraph 9-16).**

3. WING STORES JETSN, PLT JTSN, and GNR JETSN circuit breakers are closed. Pilot JETTISON SELECT switches are both positioned to OFF. Gunner JTSN SEL switch is positioned as required to jettison appropriate wing stores. Pilot collective JETTISON switch is released. The appropriate (outboard, inboard, or both) wing stores do not jettison when gunner JETTISON switch is positioned to JTSN.

STEP 1. Check for defective wiring.

**Replace or repair wiring.**

STEP 2. Check for defective GNR JTSN circuit breaker (21CB5).

**Replace circuit breaker (paragraph 9-23).**

STEP 3. Check for defective gunner JETTISON switch (21S1).

**Replace defective switch (Refer to paragraph 9-16).**

Table 9-36. **P** Troubleshooting Wing Stores Jettison Circuitry (Cont)

CONDITION

TEST OR INSPECTION

**CORRECTIVE ACTION**

STEP 4. Check for defective gunner JTSN SEL switch (21S2).

**Replace defective switch (paragraph 9-16).**

STEP 5. Check for defective or incorrectly installed diodes (21CR5, 21CR6)

**Replace defective diodes (paragraph 9-16).**

STEP 6. Check for defective gunner jettison control relay (21K5).

**Replace defective relay (paragraph 9-16).**

STEP 7. Check for defective jettison control relay (21K2).

**Replace defective relay (paragraph 9-16).**

4. With conditions same as condition 3, appropriate wing stores are properly jettisoned on one side but not on the other side when gunner JETTISON switch is positioned to JTSN.

STEP 1. Check for defective wiring.

**Repair wiring, if defective.**

STEP 2. Check for defective wing disconnectors (21J1/21P1 , 21J3/21P3)or(21J2/21P2, 21J4/21P4)on side that does not jettison properly.

**Replace defective connector (paragraph 9-16).**

**SECTION IX. **E** ARMAMENT SYSTEMS CIRCUITRY**

**9-442. **E** ARMAMENT SYSTEMS CIRCUITRY.**

**9-443. DESCRIPTION – ARMAMENT SYSTEMS CIRCUITRY.**

The armament systems consists of the turret system, wing stores armament systems, XM-138 rocket

management subsystem, M-136 helmet sight system, and M65TOW missile subsystem. Functional test and troubleshooting procedures are presented for each armament subsystem circuitry. References are made to appropriate maintenance manuals and/or chapters within this maintenance manual, where applicable. See figure 9-23 for armament electrical equipment location illustrations and refer to paragraph F-9 in Appendix F for wiring diagrams.

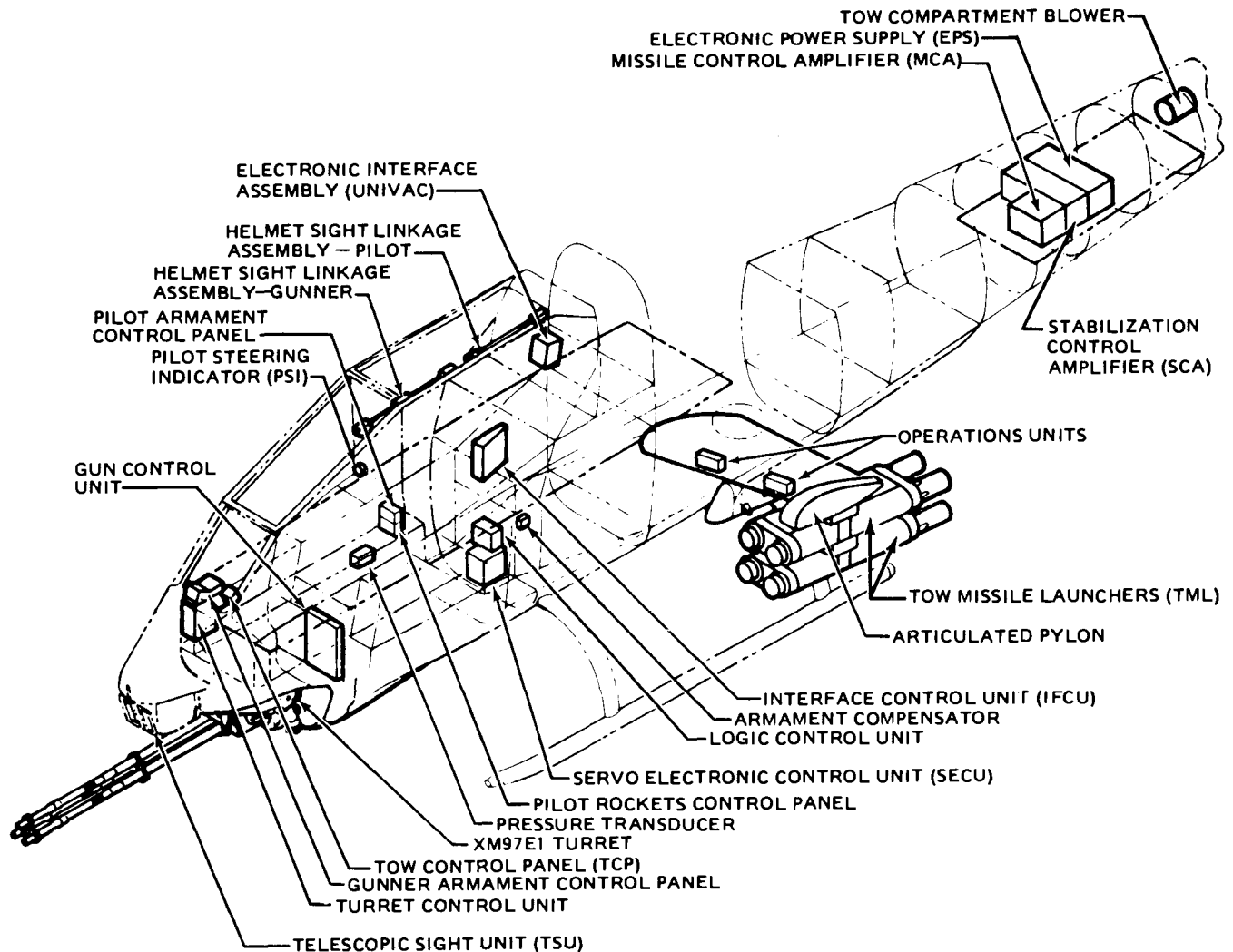

209075-391-1A

Figure 9-23. **E** Armament Equipment Location (Sheet 1 of 2)

9-443.1 **E** ARMAMENT SYSTEM RELAYS.

**a. Armament Relay Function Matrices.** The armament relay function matrices are designed to supplement the appropriate armament wiring diagram and facilitate electrical troubleshooting. Tables 9-36.1 through 9-36.6 provide the switch positions that establish the weapon mode and the switches controlling relay action. Each table provides a different mode of weapon control. The operation of each relay is dependent on the weapon mode selected. The top

portion of the table establishes the weapon mode. The lower portion of the table indicates that a relay is energized by an X under the controlling switch.

**b. Gunner Jettison Control Relay Matrix.** Table 9-36.7 shows the gunner wing stores jettison system operation. The 7- or 19-tube rocket launcher portion of the table defines the relays energized for jettison operation with 7- or 19-tube launchers installed. The 7-tube and tube-launched, optically-tracked, wire command link (TOW) launcher portion of the table define the relays energized for jettison operation with TOW and 7-tube launchers installed.

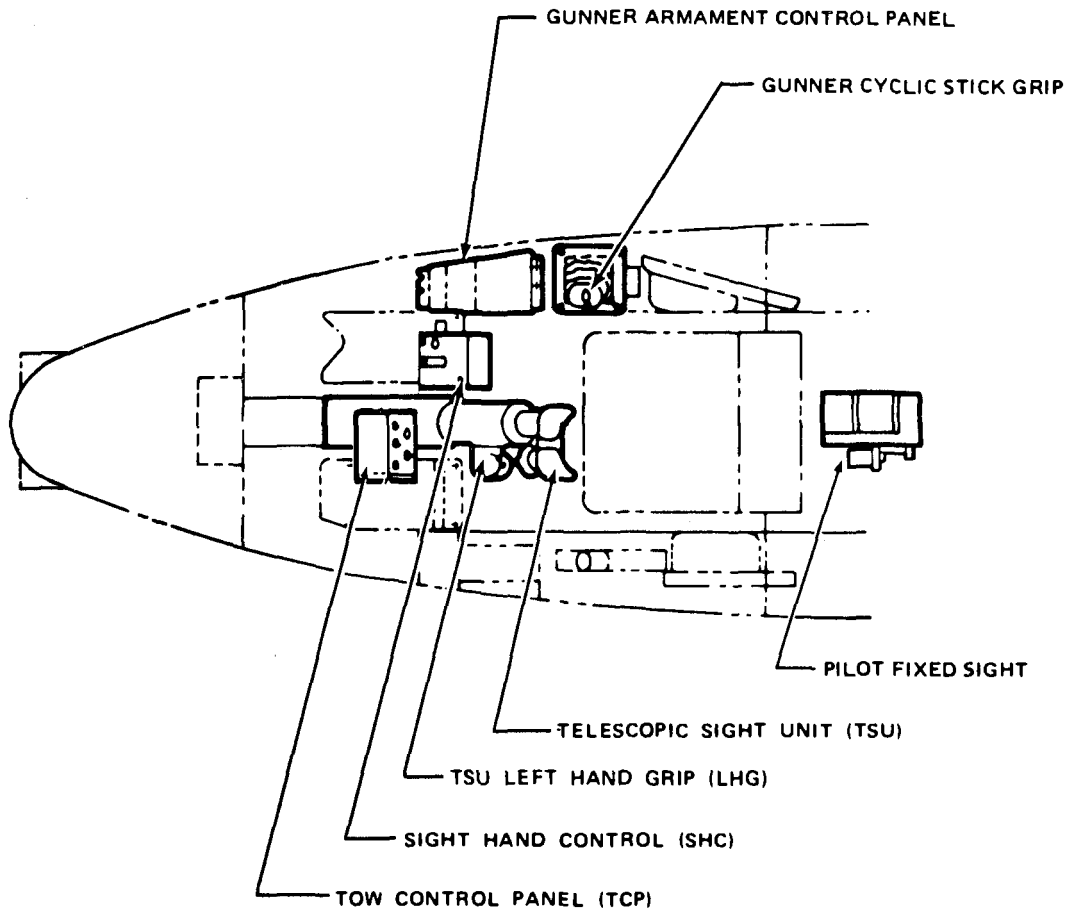

209075-391-2

**Figure 9-23. E Armament Equipment Location (Sheet 2 of 2)**

**c. Pilot Jettison Control Relay Matrix.** Table 9-36.8 shows the pilot wing stores jettison system operation. The 7- or 19-tube rocket launcher portion of the table defines the relays energized for jettison operation with 7- or 19-tube launchers installed. The 7-tube and TOW launcher portion of the table define the relays energized for jettison operation with TOW and 7-tube launchers installed.

**d. Armament System Relay Locations.** Relay locations are shown in Appendix E figure F-38.1.

**9-443.2 E DESCRIPTION - ARMAMENT SYSTEM RELAYS.**

**a. 1K5 - Emergency Hydraulic System Control Relay.**

**(1) Purpose.** To enable activation of emergency hydraulic pump when pressure is lost in hydraulic system 2.

**(2) Function.** The primary function of this relay is to turn on the emergency hydraulic pump relay to provide hydraulic pressure for flight controls. The secondary function is to turn off power to the TOW launcher hydraulic solenoid. This relay is bypassed in the boresight function for ground operation when boresighting the TOW launchers. This is a 10-amp, 4-pole, socket-mounted relay.

**(3) Relay contact logic.**

**(a) Contacts A - deenergized.** Contacts A in the deenergized position supply voltage to the TOW launcher hydraulic solenoid from the servo electronic control unit (SECU).

**(b) Contacts A - energized.** Contacts A in the energized position are open.

**(c) Contacts B.** Contacts B are not used.

Table 9-36.1 **E** Relay Matrix, Gunner in Control Mode - HSS Controlling Turret



Pilot Switches				Gunner Switches					Control		Can		Using	
MASTER ARM	WPN CONTR	WING STORE	ZONE ARM	PLT ORIDE	WING STORE	TCP	SHC	Instrument Panel	Gunner	Pilot	Fire	Acquire Target for TSU	Sight	Weapon Switch
						MODE SELECT	ACQ TRK STOW	PHS ACQ						
STBY and ARM	GUNNER	RKT/ GUN	Armed	OFF		OFF			Gunner		Turret		Helmet Sight	Left-Hand Grip TRIGGER
										Pilot	Wing Stores		Reflex	WING ARM FIRE

Relay	Pilot Switches				Gunner Switches									
	MASTER ARM		WPN CONTR	WING ARM FIRE	TCP	SHC	Left-Hand Grip							
	STBY	ARM	GUNNER	Pressed	MODE SELECT	ACQ TRK STOW	ACTION		TRIGGER					
					OFF		Pressed	1 ST Detent	2 ND Detent					
1K5 Emer Hyd Sys Control														
2K12 TRU Armament	X													
2K13 Armament	X													
2K17 Armament Control	X													
2K20 Reverse Current Control in Action										X				
19K5 Turret Gun Power													X	
19K6 Ammo Load													X	
19K7 Turret Power	X													
19K8 Burst Limit														X
19K31 Master Arm		X												
19K38 Weapon Standby	X													
19K59 Weapon Control														
19K80 Gunner Pilot Override														
19K81 Fixed Forward														
19K82 Pilot Trigger Disable														
19K83 Pilot Action Disable														
19K84 Gunner Action Disable	X													
19K85 Pilot Trigger / Action Disable														
19K86 Pilot Trigger / Action Activation														
19K87 TOW / Turret														

209475-896-1

Table 9-36.1 **E** Relay Matrix, Gunner in Control Mode - HSS Controlling Turret (Cont)

Relay	Pilot Switches				Gunner Switches				
	MASTER ARM		WPN CONTR	WING ARM FIRE	TCP	SHC	Left-Hand Grip		
	STBY	ARM	GUNNER	Pressed	MODE SELECT	ACO TRK STOW	ACTION	TRIGGER	
					OFF		Pressed	1 ST Detent	2 ND Detent
19K88 Action Interrupt									
19K91 Gunner Armament Light Dimming									
19K92 Pilot Armament Light Dimming									
19K95 Track Rate Turret Status									
19K98 Pilot Action Enable									
19K101 Reticle Flasher Bypass							X		
19K102 Range Enable		X							
19K106 Wing Stores Enable			X						
20K1 TOW Missile Sys Interlock									
20K94 TSU Track Rate Select									
21K1 M-18 Power	X								
21K2 Jettison Control									
21K3 Pilot Jettison Switch									
21K4 Pilot Jettison Control									
21K5 Gunner Jettison Control									
21K6 Wing Stores Disable									
21K7 Action Disable				X					

- X Relay energized.
-  2K12 will only operate if 2K13 is deenergized.
-  Helmet must be connected.

209475-896-2



Table 9-36.2 Relay Matrix, Gunner in Control Mode – TSU Controlling Turret

Pilot Switches				Gunner Switches					Control		Can		Using	
MASTER ARM	WPN CONTR	WING STORE	ZONE ARM	PLT ORIDE	WING STORE	TCP	SHC	Instrument Panel	Gunner	Pilot	Fire	Acquire Target for TSU	Sight	Weapon Switch
						MODE SELECT	ACQ TRK STOW	PHS ACQ						
STBY and ARM	GUNNER	RKT/ GUN	Armed	OFF		TSU/ GUN	TRK		Gunner		Turret		TSU	Left-Hand Grip TRIGGER
										Pilot	Wing Stores		Reflex	WING ARM FIRE

Relay	Pilot Switches				Gunner Switches									
	MASTER ARM		WPN CONTR	WING ARM FIRE	TCP	SHC	Gunner Armt Control Panel	Left-Hand Grip						
	STBY	ARM	GUNNER	Pressed	MODE SELECT	ACQ TRK STOW		ACTION	TRIGGER					
					TSU/ GUN	TRK	RANGE	Pressed	1 ST Detent	2 ND Detent				
1K5 Emer Hyd Sys Control														
2K12 TRU Armament	X	⚠												
2K13 Armament	X													
2K17 Armament Control	X													
2K20 Reverse Current Control in Action											X			
19K5 Turret Gun Power												X		
19K6 Ammo Load												X		
19K7 Turret Power	X													
19K8 Burst Limit														X
19K31 Master Arm		X												
19K38 Weapon Standby	X													
19K59 Weapon Control														
19K80 Gunner Pilot Override														
19K81 Fixed Forward														
19K82 Pilot Trigger Disable														
19K83 Pilot Action Disable														
19K84 Gunner Action Disable														
19K85 Pilot Trigger / Action Disable														
19K86 Pilot Trigger / Action Activation														

209475-895-1

Table 9-36.2 **E** Relay Matrix, Gunner in Control Mode - TSU Controlling Turret (Cont)

Relay	Pilot Switches				Gunner Switches						
	MASTER ARM		WPN CONTR	WING ARM FIRE	TCP	SHC	Gunner Armt Control Panel	Left-Hand Grip			
	STBY	ARM	GUNNER	Pressed	MODE SELECT	ACQ TRK STOW		ACTION	TRIGGER		
					TSU/GUN	TRK	RANGE	Pressed	1 ST Detent	2 ND Detent	
19K87 TOW / Turret											
19K88 Action Interrupt											
19K91 Gunner Armament Light Dimming											
19K92 Pilot Armament Light Dimming											
19K95 Track Rate Turret Status											
19K98 Pilot Action Enable											
19K101 Reticle Flasher Bypass								X			
19K102 Range Enable		X									
19K106 Wing Stores Enable			X								
20K1 TOW Missile Sys Interlock					X						
20K94 TSU Track Rate Select							X				
21K1 M-18 Power	X										
21K2 Jettison Control											
21K3 Pilot Jettison Switch											
21K4 Pilot Jettison Control											
21K5 Gunner Jettison Control											
21K6 Wing Stores Disable											
21K7 Action Disable				X							

X Relay energized.

 2K12 will only operate if 2K13 is deenergized.

209475-895-2

Table 9-36.3 **E** Relay Matrix, Gunner Controlling TOW and Pilot Controlling Turret and Wing Stores Mode

Pilot Switches				Gunner Switches					Control		Can		Using	
MASTER ARM	WPN CONTR	WING STORE	ZONE ARM	PLT ORIDE	WING STORE	TCP	SHC	Instrument Panel	Gunner	Pilot	Fire	Acquire Target for TSU	Sight	Weapon Switch
						MODE SELECT	ACQ TRK STOW	PHS ACQ						
STBY and ARM	GUNNER	RKT/ GUN	Armed	OFF	ARMED	TRK						Turret	Helmet Sight	TRIGGER TURRET FIRE
												Wing Stores	Reflex	WING ARM FIRE
												TOW	TSU	Left-Hand Grip TRIGGER

Relay	Pilot Switches						Gunner Switches											
	MASTER ARM		WPN CONTR	TRIGGER ACTION	TRIGGER TURRET FIRE		TCP	SHC	Left-Hand Grip									
	STBY	ARM	GUNNER	Pressed	1 ST Detent	2 ND Detent	MODE SELECT	ACQ TRK STOW	ACTION	TRIGGER	1 ST Detent	2 ND Detent						
					ARMED	TRK	Pressed											
1K5 Emer Hyd Sys Control																		
2K12 TRU Armament	X																	
2K13 Armament	X																	
2K17 Armament Control	X																	
2K20 Reverse Current Control in Action				X														
19K5 Turret Gun Power						X												
19K6 Ammo Load						X												
19K7 Turret Power	X																	
19K8 Burst Limit						X												
19K31 Master Arm		X																
19K38 Weapon Standby	X																	
19K59 Weapon Control									X									
19K80 Gunner Pilot Override									X									
19K81 Fixed Forward									X									
19K82 Pilot Trigger Disable											X							
19K83 Pilot Action Disable	X																	
19K84 Gunner Action Disable																		
19K85 Pilot Trigger / Action Disable															X			
19K86 Pilot Trigger / Action Activation									X									

209475-894-1

Table 9-36.3 **E** Relay Matrix, Gunner Controlling TOW and Pilot Controlling Turret and Wing Stores Mode (Cont)

Relay	Pilot Switches						Gunner Switches				
	MASTER ARM		WPN CONTR	TRIGGER ACTION	TRIGGER TURRET FIRE		TCP	SHC	Left-Hand Grip		
	STBY	ARM	GUNNER	Pressed	1 ST Detent	2 ND Detent	MODE SELECT	ACQ TRK STOW	ACTION	TRIGGER	
							ARMED	TRK	Pressed	1 ST Detent	2 ND Detent
19K87 TOW / Turret							X				
19K88 Action Interrupt											
19K91 Gunner Armament Light Dimming											
19K92 Pilot Armament Light Dimming											
19K95 Track Rate Turret Status							X				
19K98 Pilot Action Enable							X				
19K101 Reticle Flasher Bypass				X							
19K102 Range Enable		X									
19K106 Wing Stores Enable											
20K1 TOW Missile Sys Interlock							X				
20K94 TSU Track Rate Select											
21K1 M-18 Power	X										
21K2 Jettison Control											
21K3 Pilot Jettison Switch											
21K4 Pilot Jettison Control											
21K5 Gunner Jettison Control											
21K6 Wing Stores Disable										X	
21K7 Action Disable											

X Relay energized.



2K12 will only operate if 2K13 is deenergized.



Helmet must be connected.



Table 9-36.4 **E** Relay Matrix, Pilot in Control Mode (Cont)

Relay	Pilot Switches						Gunner Switches				
	MASTER ARM		WPN CONTR	TRIGGER ACTION	TRIGGER TURRET FIRE		TCP	SHC	Left-Hand Grip		
	STBY	ARM	PILOT	Pressed	1 ST Detent	2 ND Detent	MODE SELECT	ACQ TRK STOW	ACTION	TRIGGER	
							OFF			1 ST Detent	2 ND Detent
19K87 TOW / Turret											
19K88 Action Interrupt											
19K91 Gunner Armament Light Dimming											
19K92 Pilot Armament Light Dimming											
19K95 Track Rate Turret Status											
19K98 Pilot Action Enable			X								
19K101 Reticle Flasher Bypass				X							
19K102 Range Enable		X									
19K106 Wing Stores Enable			X								
20K1 TOW Missile Sys Interlock											
20K94 TSU Track Rate Select											
21K1 M-18 Power	X										
21K2 Jettison Control											
21K3 Pilot Jettison Switch											
21K4 Pilot Jettison Control											
21K5 Gunner Jettison Control											
21K6 Wing Stores Disable											
21K7 Action Disable				X							

X Relay energized.

 2K12 will only operate if 2K13 is deenergized.

209475-893-2

Table 9-36.5 **E** Relay Matrix, Pilot Override Mode

Pilot Switches				Gunner Switches					Control		Can		Using	
MASTER ARM	WPN CONTR	WING STORE	ZONE ARM	PLT ORIDE	WING STORE	TCP	SHC	Instrument Panel	Gunner	Pilot	Fire	Acquire Target for TSU	Sight	Weapon Switch
						MODE SELECT	ACQ TRK STOW	PHS ACQ						
				PLT ORIDE	RKT/ GUN				Gunner		Turret		Helmet Sight	TRIGGER TURRET FIRE
											Wing Stores		None	WING ARM FIRE

Relay	Pilot Switches			Gunner Switches									
	MASTER ARM		WPN CONTR	TCP	SHC	Left-Hand Grip		PLT ORIDE	TRIGGER ACTION	TRIGGER TURRET FIRE		WING ARM FIRE	
	STBY	ARM		MODE SELECT	ACQ TRK STOW	ACTION	TRIGGER		PLT ORIDE	Pressed	1 ST Detent	2 ND Detent	Pressed
							1 ST	2 ND					
1K5 Emer Hyd Sys Control													
2K12 TRU Armament								X <sup>1</sup>					
2K13 Armament								X					
2K17 Armament Control								X					
2K20 Reverse Current Control in Action									X				
19K5 Turret Gun Power											X		
19K6 Ammo Load											X		
19K7 Turret Power								X					
19K8 Burst Limit												X	
19K31 Master Arm								X					
19K38 Weapon Standby								X					
19K59 Weapon Control													
19K80 Gunner Pilot Override								X					
19K81 Fixed Forward													
19K82 Pilot Trigger Disable													
19K83 Pilot Action Disable													
19K84 Gunner Action Disable								X <sup>2</sup>					
19K85 Pilot Trigger / Action Disable													
19K86 Pilot Trigger / Action Activation													

209475-892-1

Table 9-36.5 **E** Relay Matrix, Pilot Override Mode (Cont)

Relay	Pilot Switches			Gunner Switches											
	MASTER ARM		WPN CONTR	TCP	SHC	Left-Hand Grip			PLT ORIDE	TRIGGER ACTION	TRIGGER TURRET FIRE		WING ARM FIRE		
	STBY	ARM		MODE SELECT	ACQ TRK STOW	ACTION	TRIGGER		PLT ORIDE	Pressed	1 ST Detent	2 ND Detent	Pressed		
						1 ST Detent	2 ND Detent								
19K87 TOW/Turret															
19K88 Action Interrupt															
19K91 Gunner Armament Light Dimming															
19K92 Pilot Armament Light Dimming															
19K95 Track Rate Turret Status															
19K98 Pilot Action Enable															
19K101 Reticle Flasher Bypass														X	
19K102 Range Enable									X						
19K106 Wing Stores Enable															
20K1 TOW Missile Sys Interlock															
20K94 TSU Track Rate Select															
21K1 M-18 Power									X						
21K2 Jettison Control															
21K3 Pilot Jettison Switch															
21K4 Pilot Jettison Control															
21K5 Gunner Jettison Control															
21K6 Wing Stores Disable															
21K7 Action Disable															X



- X Relay energized.
- 1 2K12 will only operate if 2K13 is deenergized.
- 2 Helmet must be connected.

209475-892-2



Table 9-36.6 **E** Relay Matrix, TSU Acquisition of Target with Gunner or Pilot HSS Mode

Pilot Switches				Gunner Switches					Control		Can		Using	
MASTER ARM	WPN CONTR	WING STORE	ZONE ARM	PLT ORIDE	WING STORE	TCP	SHC	Instrument Panel	Gunner	Pilot	Fire	Acquire Target for TSU	Sight	Weapon Switch
						MODE SELECT	ACQ TRK STOW	PHS ACQ						
STBY and ARM	GUNNER	RKT/ GUN		OFF		TSU/ GUN	ACQ		Gunner			Acquire	Gunner Helmet Sight	
							TRK	Press	Gunner			Acquire	Pilot Helmet Sight	

Relay	Pilot Switches				Gunner Switches			
	MASTER ARM		WPN CONTR		TCP	SHC		PHS ACQ
	STBY	ARM	GUNNER	TSU/GUN	MODE SELECT	ACQ/TRK/STOW		
					ACQ	TRK	Pressed	
1K5 Emer Hyd Sys Control								
2K12 TRU Armament	X							
2K13 Armament	X							
2K17 Armament Control	X							
2K20 Reverse Current Control in Action								
19K5 Turret Gun Power								
19K6 Ammo Load								
19K7 Turret Power	X							
19K8 Burst Limit								
19K31 Master Arm		X						
19K38 Weapon Standby	X							
19K59 Weapon Control								
19K80 Gunner Pilot Override								
19K81 Fixed Forward								
19K82 Pilot Trigger Disable								
19K83 Pilot Action Disable	X							
19K84 Gunner Action Disable	X							
19K85 Pilot Trigger/Action Disable								
19K86 Pilot Trigger/Action Activation								

209475-891-1

Table 9-36.6 **E** Relay Matrix, TSU Acquisition of Target with Gunner or Pilot HSS Mode (Cont)

Relay	Pilot Switches			Gunner Switches			
	MASTER ARM		WPN CONTR	TCP	SHC		PHS ACQ
	STBY	ARM	GUNNER	MODE SELECT	ACQ/TRK/STOW		
				TSU/GUN	ACQ	TRK	Pressed
19K87 TOW/Turret							
19K88 Action Interrupt					X		X
19K91 Gunner Armament Light Dimming							
19K92 Pilot Armament Light Dimming							
19K95 Track Rate Turret Status							
19K98 Pilot Action Enable							
19K101 Reticle Flasher Bypass							
19K102 Range Enable		X					
19K106 Wing Stores Enable							
20K1 TOW Missile Sys Interlock							
20K94 TSU Track Rate Select							
21K1 M-18 Power	X						
21K2 Jettison Control							
21K3 Pilot Jettison Switch							
21K4 Pilot Jettison Control							
21K5 Gunner Jettison Control							
21K6 Wing Stores Disable							
21K7 Action Disable							

X Relay energized.

1 2K12 will only operate if 2K13 is deenergized.

2 Helmet must be connected.

209475-891-2

Table 9-36.7 **E** Relay Matrix, Gunner Jettison Mode

**WARNING**

Ensure jettison cartridges are removed from ejector racks before performing checks.

**NOTE**

Ensure WING STORES JTSN, GNR JTSN, and PLT JTSN circuit breakers are closed.

7- or 19-Tube Rocket Launcher – 4 Stations					
Relay	Gunner Instrument Panel				
	WING STORES JETTISON Switch		JTSN SEL Switch		
	Off	On	OUTBD	BOTH	INBD
21K5 Gunner Jettison Control		On		X	X

TOW Launcher Outboard – 7 -Tube Rocket Launcher Inboard					
Relay	Gunner Instrument Panel				
	WING STORES JETTISON Switch		JTSN SEL Switch		
	Off	On	OUTBD	BOTH	INBD
21K2 Jettison Control	*	*	*	*	*
21K5 Gunner Jettison Control		On		X**	X**

x Relay energized

\* Relay 21K2 is not controlled by any switch; rather, it is energized anytime right or left lower outboard TOW launcher is electrically connected.

\*\* Relay 21K5 cannot be energized if 21K2 is energized.

209475-882

Table 9-36.8 **E** Relay Matrix, Pilot Jettison Mode

**WARNING**

Ensure jettison cartridges are removed from ejector racks before performing checks.

NOTE

Ensure WING STORES JTSN, GNR JTSN, and PLT JTSN circuit breakers are closed.

7- or 19-Tube Rocket Launcher – 4 Stations			
Relay	Pilot Collective	Pilot Misc Control Panel	
	JETTISON Switch	JETTISON SELECT	
	Pressed	OUTBD	INBD
21K3 Pilot Jettison Switch	X		
21K4 Pilot Jettison Control			X

TOW Launcher Outboard – 7 -Tube Rocket Launcher Inboard			
Relay	Pilot Collective	Pilot Misc Control Panel	
	JETTISON Switch	JETTISON SELECT	
	Pressed	OUTBD	INBD
21K2 Jettison Control	*	*	*
21K3 Pilot Jettison Switch	X		
21K4 Pilot Jettison Control			X**

x Relay energized

\* Relay 21K2 is not controlled by any switch; rather, it is energized anytime right or left lower outboard TOW launcher is electrically connected.

\*\* Relay 21K4 cannot be energized if 21K2 is energized; also, relay 21K4 cannot be energized unless 21K3 is energized.

209475-881

**(d) Contacts C - deenergized.** Contacts C in the deenergized position are open.

**(e) Contacts C - energized.** Contacts C in the energized position turn on the emergency hydraulic pump relay (1K4).

**(f) Contacts D. Contacts D are not used.**

**b. 2K12 - Transformer Rectifier Unit Armament Relay.**

**(1) Purpose.** To supply voltage to the armament bus from the transformer rectifier unit (TRU).

**(2) Function.** This relay supplies voltage to the armament bus when the MASTER ARM switch is on if there is no voltage on the transfer bus. Relay 2K12 cannot be energized if 2K13 is energized. This is a 200-amp, single-pole relay.

**(3) Relay contact logic.**

**(a) Contacts A - deenergized.** Contacts A in the deenergized position are open.

**(b) Contacts A - energized.** Contacts A in the energized position connect the TRU bus to the armament bus.

**c. 2K13 - Armament Relay.**

**(1) Purpose.** To supply voltage to the armament bus from the generator or the ground power unit.

**(2) Function.** This relay supplies voltage to the armament bus when the MASTER ARM switch is on and there is voltage on the transfer bus. This is a 200-amp, single-pole relay, with auxiliary contacts.

**(3) Relay contact logic.**

**(a) Contacts A - deenergized.** Contacts A in the deenergized position are open.

**(b) Contacts A - energized.** Contacts A in the energized position connect the armament bus to the transfer bus.

**(c) Contacts auxiliary 11 and 12.** Auxiliary contacts 11 and 12 are not used.

**(d) Contacts auxiliary 13 and 14 - deenergized.** Auxiliary contacts 13 and 14 in the

deenergized position are in the circuit from the TRU bus to the coil of 2K12.

**(e) Contacts auxiliary 13 and 14 - energized.** Auxiliary contacts 13 and 14 in the energized position are open and 2K12 cannot be energized.

**d. 2K17 - Armament Control Relay.**

**(1) Purpose.** This relay controls which voltage source is supplied to the armament bus.

**(2) Function.** If the generator is operating, 2K13 will supply voltage to the armament bus. If the generator is not operating and the alternator is, the TRU will supply voltage to the armament bus through 2K12. This is a 10-amp, 4-pole, socket-mounted relay.

**(3) Relay contact logic.**

**(a) Contacts A - deenergized.** Contacts A in the deenergized position are open.

**(b) Contacts A - energized.** Contacts A in the energized position will allow 2K12 to energize if 2K13 is not energized.

**(c) Contacts B - deenergized.** Contacts B in the deenergized position are open.

**(d) Contacts B - energized.** Contacts B in the energized position provide voltage to the coil of 2K13.

**(e) Contacts C - deenergized.** Contacts C in the deenergized position are open.

**(f) Contacts C - energized.** Contacts C in the energized position determine the voltage source for the armament system, i.e., generator, external power, or TRU.

**(g) Contacts D. Contacts D are not used.**

**e. 2K20 - Reverse Current Control in Action Relay.**

**(1) Purpose.** To lock the reverse current relay in the on condition during turret action.

**(2) Function.** To eliminate contact chatter during turret operation. This is a 10-amp, 2-pole, time-delay-on-dropout relay.

**(3) Relay contact logic.**

**(a) Contacts A - deenergized.** Contacts A in the deenergized position are open.

**(b) Contacts A - energized.** Contacts A (pins C, F, and B) in the energized position connect the reverse current relay terminal APP to terminal SW.

**(c) Contacts B.** Contacts B (pins D, H, and G) are not used.

**f. 19K5 - Turret Gun Power Relay.**

**(1) Purpose.** This relay supplies voltage to the turret for gun motor drive.

**(2) Function.** When the TRIGGER TURRET FIRE switch is pressed, the turret logic control will close 19K5 to fire the gun if all the turret fire constraints have been complied with. This is a 100-amp, single-pole relay.

**(3) Relay contact logic.**

**(a) Contacts A - deenergized. Contacts A in the deenergized position are open.**

**(b) Contacts A - energized.** Contacts A in the energized position apply voltage to the gun drive motor in the turret.

**g. 19K6 - Ammo Load Relay.**

**(1) Purpose.** This relay provides the power for the ammo booster motor on the ammo can.

**(2) Function.** This relay is controlled by the turret system to assist ammo feed during gunfire. This is a .25-amp, single-pole relay.

**(3) Relay contact logic.**

**(a) Contacts A - deenergized.** Contacts A in the deenergized position are open.

**(b) Contacts A - energized.** Contacts A in the energized position apply voltage to the ammo booster motor on the ammo can.

**h. 19K7 - Turret Power Relay.**

**(1) Purpose.** To supply 28 Vdc power to the turret control assembly for turret drive.

**(2) Function.** This relay is controlled by the turret gun control assembly. When the standby power is applied to the gun control assembly, it turns on the 19K7 relay approximately 2.0 seconds later. This is a 200-amp, single-pole relay.

**(3) Relay contact logic.**

**(a) Contacts A - deenergized.** Contacts A in the deenergized position are open.

**(b) Contacts A - energized.** Contacts A in the energized position connect the armament bus to the turret control assembly.

**i. 19K8 - Burst Limit Relay.**

**(1) Purpose.** To control turret gunfire mode either burst limit or continuous fire.

**(2) Function.** This relay is in the burst limit circuit to the turret gun control assembly and is controlled by the second detent of the TRIGGER TURRET FIRE switch. This is a 10-amp, 2-pole, socket-mounted relay.

**(3) Relay contact logic.**

**(a) Contacts A - deenergized.** Contacts A in the deenergized position are in the circuit to the gun control assembly to provide burst limit anytime the TRIGGER TURRET FIRE switch is pressed.

**(b) Contacts A - energized.** Contacts A in the energized position open the burst limit circuit to allow continuous turret fire.

**(c) Contacts B.** Contacts B are not used.

**j. 19K31 - Master Arm Relay.**

**(1) Purpose.** To provide master arm power to each weapon system.

**(2) Function.** The master arm relay is controlled by the ARM position of the MASTER ARM switch. Master arm power is required to fire any weapon. This is a 10-amp, 4-pole, screw-terminal relay.

**(3) Relay contact logic.**

**(a) Contacts A - deenergized.** Contacts A in the deenergized position supply voltage through the weapon standby relay (19K38) to the pilot and gunner STBY light.

**(b) Contacts A - energized.** Contacts A in the energized position supply voltage through the weapon standby relay (19K38) to the pilot and gunner ARMED light.

**(c) Contacts B - deenergized.** Contacts B in the deenergized position are open.

**(d) Contacts B - energized.** Contacts B in the energized position supply voltage from the TURRET CONTR circuit breaker to the turret gun control assembly.

**(e) Contacts C.** Contacts C are not used.

**(f) Contacts D - deenergized.** Contacts D in the deenergized position are open.

**(g) Contacts D - energized.** Contacts D in the energized position supply voltage from the WING STORE PWR circuit breaker to the rocket management system.

#### k. 19K38 - Weapon Standby Relay.

**(1) Purpose.** To provide standby power and control for each weapon system.

**(2) Function.** The weapon standby relay allows control and operation of each weapon system. It is controlled by the STBY position of the MASTER ARM switch. This is a 10-amp, 4-pole, socket-mounted relay.

#### (3) Relay contact logic.

**(a) Contacts A - deenergized.** Contacts A in the deenergized position are open.

**(b) Contacts A - energized.** Contacts A in the energized position supply power from the WPN CONTR circuit breaker to 19K31 for control of the STBY and ARMED lights on the pilot and gunner control panels.

**(c) Contacts B - deenergized.** Contacts B in the deenergized position are open.

**(d) Contacts B - energized.** Contacts B in the energized position provide standby power to the turret gun control assembly.

**(e) Contacts C - deenergized.** Contacts C in the deenergized position are open.

**(f) Contacts C - energized.** Contacts C in the energized position provide standby power to 19TB4 block 4 for distribution and logic control.

**(g) Contacts D - deenergized.** Contacts D in the deenergized position are open.

**(h) Contacts D - energized.** Contacts D in the energized position supply 115 Vac from the TURRET PWR circuit breaker to the turret gun control assembly.

#### l. 19K59 - Weapon Control Relay.

**(1) Purpose.** To switch the turret range control from the gunner to the pilot when the pilot has control of the turret.

**(2) Function.** In the pilot-in-control mode or TOW mode, the pilot has control of the turret and 19K59 is energized. This is a 10-amp, 4-pole, socket-mounted relay.

#### (3) Relay contact logic.

**(a) Contacts A.** Contacts A are not used.

**(b) Contacts B.** Contacts B are not used.

**(c) Contacts C - deenergized.** Contacts C in the deenergized position connect the MED (1.5 km) position of the gunner RANGE switch to the interface control unit (IFCU).

**(d) Contacts C - energized.** Contacts C in the energized position connect the MED (1.5 km) position of the pilot RANGE switch to the IFCU.

**(e) Contacts D - deenergized.** Contacts D in the deenergized position connect the SHORT (1 km) position on the gunner RANGE switch to the IFCU.

**(f) Contacts D - energized.** Contacts D in the energized position connect the SHORT (1 km) position on the pilot RANGE switch to the IFCU.

#### m. 19K80 - Gunner Pilot Override Relay.

**(1) Purpose.** To allow the gunner to take control of the weapons if the pilot is disabled.

**(2) Function.** The override mode allows the gunner to fire the turret and rocket system from his cyclic grip while flying the helicopter. This is a 10-amp, 6-pole, socket-mounted relay.

**(3) Relay contact logic.**

**(a) Contacts A - deenergized.** Contacts A in the deenergized position provide weapon control power to the WPN CONTR switch.

**(b) Contacts A - energized.** Contacts A in the energized position provide weapon control power to the gunner TRIGGER ACTION switch.

**(c) Contacts B - deenergized.** Contacts B in the deenergized position provide arm power to the WPN CONTR switch.

**(d) Contacts B - energized.** Contacts B in the energized position provide arm power to the gunner TRIGGER ACTION switch.

**(e) Contacts C - deenergized.** Contacts C in the deenergized position provide arm power to the pilot WING ARM FIRE switch.

**(f) Contacts C - energized.** Contacts C in the energized position provide arm power to the gunner WING ARM FIRE switch.

**(g) Contacts D - deenergized.** Contacts D in the deenergized position are open.

**(h) Contacts D - energized.** Contacts D in the energized position provide weapon fire voltage to energize the master arm relay (19K31).

**(i) Contacts E.** Contacts E are not used.

**(j) Contacts F - deenergized.** Contacts F in the deenergized position are open.

**(k) Contacts F - energized.** Contacts F in the energized position provide weapon control voltage to the weapon standby relay (19K38).

**n. 19K81 - Fixed Forward Relay.**

**(1) Purpose.** To switch additional circuits when the WPN CONTR switch is in the FIXED position.

**(2) Function.** Relay 19K81 switches the pilot TRIGGER TURRET FIRE switch to the fixed mode and opens the action and ground depression limit circuits. This is a 10-amp, 4-pole, socket-mounted relay.

**(3) Relay contact logic.**

**(a) Contacts A - deenergized.** Contacts A in the deenergized position provide voltage to allow the pilot helmet sight to control the turret.

**(b) Contacts A - energized.** Contacts A in the energized position are open.

**(c) Contacts B - deenergized.** Contacts B in the deenergized position are in the circuit to the turret ground depression limit.

**(d) Contacts B - energized.** Contacts B in the energized position open the ground depression limit circuit.

**(e) Contacts C.** Contacts C are not used.

**(f) Contacts D - deenergized.** Contacts D in the deenergized position provide voltage to the pilot TRIGGER TURRET FIRE switch when the WPN CONTR switch is in the PILOT position.

**(g) Contacts D - energized.** Contacts D in the energized position provide voltage to the pilot TRIGGER TURRET FIRE switch when the WPN CONTR switch is in the FIXED position.

**o. 19K82 - Pilot Trigger Disable Relay.**

**(1) Purpose.** Relays 19K82 and 19K85 are used together to provide a controlled interrupt sequence of the pilot trigger and action circuits during TOW missile launch.

**(2) Function.** Relay 19K82 is controlled by the launcher activate signal from the TOW stabilization control amplifier (SCA). This is a 10-amp, 2-pole, time-delay-on-dropout relay. The time is fixed at 0.5 second.

**(3) Relay contact logic.**

**(a) Contacts A - deenergized. Contacts A (pins C and F) in the deenergized position are open.**

**(b) Contacts A - energized.** Contacts A (pins F and B) in the energized position provide a ground for the coil of 19K85.

**(c) Contacts B.** Contacts B (pins D, G, and H) are not used.



**p. 19K83 - Pilot Action Disable Relay.**

**(1) Purpose.** To detect separation of pilot helmet sight and control arm.

**(2) Function.** To open the pilot action circuit and turn off the sight reticle when the control arm is not connected to the pilot helmet. This is a 10-amp, 2-pole, socket-mounted relay.

**(3) Relay contact logic.**

**(a) Contacts A - deenergized.** Contacts A in the deenergized position are open.

**(b) Contacts A - energized.** Contacts A in the energized position are in the pilot action circuit to complete the circuit from the pilot TRIGGER ACTION switch to the electronic interface assembly (EIA).

**(c) Contacts B - deenergized.** Contacts B in the deenergized position are open.

**(d) Contacts B - energized.** Contacts B in the energized position are in the circuit to the pilot helmet sight reticle.

**q. 19K84 - Gunner Action Disable Relay.**

**(1) Purpose.** To detect separation of gunner helmet sight and control arm.

**(2) Function.** To open the gunner TRIGGER ACTION switch circuit and turn off the helmet sight reticle when the helmet is not connected to the control arm. This is a 10-amp, 4-pole, socket-mounted relay.

**(3) Relay contact logic.**

**(a) Contacts A - deenergized.** Contacts A in the deenergized position are open.

**(b) Contacts A - energized.** Contacts A in the energized position are in the circuit from the gunner TRIGGER ACTION switch to the turret and are active only in pilot override mode.

**(c) Contacts B - deenergized.** Contacts B in the deenergized position send the telescopic sight unit (TSU) left-hand grip (LHG) action signal to the IFCU.

**(d) Contacts B - energized.** Contacts B in the energized position send the TSU left-hand grip (LHG) action signal to the turret.

**(e) Contacts C - deenergized.** Contacts C in the deenergized position are open.

**(f) Contacts C - energized.** Contacts C in the energized position provide a ground for the gunner helmet sight reticle.

**(g) Contacts D.** Contacts D are not used.

**r. 19K85 - Pilot Trigger/Action Disable Relay.**

**(1) Purpose.** To disable pilot trigger and action circuits during TOW missile launch.

**(2) Function.** The TOW trigger signal will engage 19K85 if 19K82 is engaged and 19K85 will stay closed after the trigger is released as long as 19K82 remains closed. This provides controlled interrupt sequence of the pilot trigger and action circuits of approximately 3 seconds during TOW missile launch. This is a 10-amp, 2-pole, socket-mounted relay.

**(3) Relay contact logic.**

**(a) Contacts A - deenergized.** Contacts A in the deenergized position are in the circuit to provide voltage to the pilot TRIGGER ACTION switch when in the TOW mode.

**(b) Contacts A - energized.** Contacts A in the energized position are open.

**(c) Contacts B - deenergized.** Contacts B in the deenergized position are in the circuit to provide voltage to the pilot TRIGGER TURRET FIRE switch when in the TOW mode.

**(d) Contacts B - energized.** Contacts B in the energized position apply voltage to the coil of 19K85 and will remain closed until 19K82 opens.

**s. 19K86 - Pilot Trigger/Action Activation Relay.**

**(1) Purpose.** To provide the pilot control of the turret when the gunner is in a TOW Mode.

**(2) Function.** Relay 19K86 is controlled by 19K87 to give the pilot control of the turret when in the TOW mode. This is a 10-amp, 2-pole, socket-mounted relay.

**(3) Relay contact logic.**

**(a) Contacts A - deenergized.** Contacts A in the deenergized position are open.

**(b) Contacts A - energized.** Contacts A in the energized position provide voltage to the pilot TRIGGER ACTION switch through 19K85.

**(c) Contacts B - deenergized.** Contacts B in the deenergized position are open.

**(d) Contacts B - energized.** Contacts B in the energized position are used to place the gun in a zero elevation position through 19K85.

**t. 19K87 - TOW/Turret Relay.**

**(1) Purpose.** To transfer the gunner left-hand grip (LHG) action and trigger circuits from the turret to the TOW system.

**(2) Function.** To give the pilot control of the turret when the gunner takes control of the TOW. This is a 10-amp, 4-pole, socket-mounted relay.

**(3) Relay contact logic.**

**(a) Contacts A - deenergized.** Contacts A in the deenergized position are in the circuit from the TSU left-hand grip (LHG) ACTION switch to the turret.

**(b) Contacts A - energized.** Contacts A in the energized position are open.

**(c) Contacts B - deenergized.** Contacts B in the deenergized position provide a voltage to the pilot TRIGGER ACTION switch to enable the pilot to interrupt gunner turret fire.

**(d) Contacts B - energized.** Contacts B in the energized position provide a voltage to the pilot TRIGGER ACTION switch for control of the turret.

**(a) Contacts C - deenergized.** Contacts C in the deenergized position are in the circuit from the TSU left-hand grip (LHG) TRIGGER switch (second detent) to the turret burst limit relay (19K8).

**(f) Contacts C - energized.** Contacts C in the energized position are open.

**(g) Contacts D - deenergized.** Contacts D in the deenergized position provide a circuit from the TSU

left-hand grip (LHG) TRIGGER switch (first detent) to the turret.

**(h) Contacts D - energized.** Contacts D in the energized position provide a circuit from the TSU left-hand grip (LHG) TRIGGER switch (first detent) to the TOW system.

**u. 19K88 - Action Interrupt Relay.**

**(1) Purpose.** To open the turret action circuit during TSU acquisition mode.

**(2) Function.** This relay is controlled by the gunner ACQ/TRK/STOW and PHS ACQ switches to open the action circuit to the turret when no sight signal is available to the turret. This is a 10-amp, 2-pole, socket-mounted relay.

**(3) Relay contact logic.**

**(a) Contacts A - deenergized.** Contacts A in the deenergized position are in the action circuit to the turret.

**(b) Contacts A - energized.** Contacts A in the energized position open the action circuit to the turret.

**(c) Contacts B.** Contacts B are not used.

**v. 19K91 - Gunner Armament Light Dimming Relay.**

**NOTE**

**NVG light dimming system will be deactivated with the incorporation of MWO 55-1520-236-50-4.**

**(1) Purpose.** To control dimming of the gunner PILOT IN CONT, ARMED, and STBY lights when in the night vision goggle (NVG) mode.

**(2) Function.** Relay 19K91 is controlled by the LT switch on the gunner miscellaneous control panel. If the gunner is in the pilot override mode, 19K91 is controlled by the LTS switch on the gunner cyclic grip. This is a 10-amp, 4-pole, socket-mounted relay.

**(3) Relay contact logic.**

**(a) Contacts A - deenergized.** Contacts A in the deenergized position provide full voltage to the gunner STBY light.

**(b) Contacts A - energized.** Contacts A in the energized position provide a reduced voltage to the gunner STBY light through resistor 19R5.

**(c) Contacts B - deenergized.** Contacts B in the deenergized position provide full voltage to the gunner ARMED light.

**(d) Contacts B - energized.** Contacts B in the energized position provide a reduced voltage to the gunner ARMED light through resistor 19R6.

**(e) Contacts C - deenergized.** Contacts C in the deenergized position provide full voltage to the gunner PILOT IN CONT light.

**(f) Contacts C - energized.** Contacts C in the energized position provide a reduced voltage to the gunner PILOT IN CONT light through resistor 19R15.

**(g) Contacts D.** Contacts D are not used.

**w. 19K92 - Pilot Armament Light Dimming Relay.**

**NOTE**

**NVG light dimming system will be deactivated with the incorporation of MWO 55-1520-236-50-4.**

**(1) Purpose.** To control the light level for ARMED and STBY lights.

**(2) Function.** If the pilot NVG ENBL switch is positioned to NVG ENBL, the NVG position of the LTS switch on the pilot cyclic grip will control 19K92 and place the pilot armament lights in the night vision mode. This is a 10-amp, 2-pole, socket-mounted relay.

**(3) Relay contact logic.**

**(a) Contacts A - deenergized.** Contacts A in the deenergized position provide full voltage to the pilot STBY light.

**(b) Contacts A - energized.** Contacts A in the energized position provide reduced voltage to the pilot STBY light through resistor 19R13.

**(c) Contacts B - deenergized.** Contacts B in the deenergized position provide full voltage to the pilot ARMED light.

**(d) Contacts B - energized.** Contacts B in the energized position provide reduced voltage to the pilot ARMED light through resistor 19R14.

**x. 19K95 - Track Rate Turret Status Relay.**

**(1) Purpose.** To open the turret status circuit to the telescopic sight unit (TSU) when in the TOW Mode.

**(2) Function.** When a TOW mode is selected by the gunner, 19K95 interrupts the gun flag signal to the TSU and the stabilization control amplifier (SCA). Relay 19K95 also energizes the fixed forward relay (19K81) to place the turret in a fixed forward position. This is a 10-amp, 2-pole, socket-mounted relay.

**(3) Relay contact logic.**

**(a) Contacts A - deenergized.** Contacts A in the deenergized position are in the turret status circuit to the TSU and the SCA.

**(b) Contacts A - energized.** Contacts A in the energized position are open.

**(c) Contacts B - deenergized.** Contacts B in the deenergized position are open.

**(d) Contacts B - energized.** Contacts B in the energized position energize the fixed forward relay (19K81) to position the gun to 0° azimuth and 0° elevation.

**y. 19K98 - Pilot Action Enable Relay.**

**(1) Purpose.** To apply a voltage to the pilot cyclic TRIGGER TURRET FIRE switch.

**(2) Function.** In the TOW mode and pilot-in-control mode, 19K98 is controlled by the pilot TRIGGER ACTION switch to apply voltage to the pilot TRIGGER TURRET FIRE switch. This is a 10-amp, 2-pole, socket-mounted relay.

**(3) Relay contact logic.**

**(a) Contacts A - deenergized.** Contacts A in the deenergized position are open.

**(b) Contacts A - energized.** Contacts A in the energized position provide voltage to the pilot TRIGGER TURRET FIRE switch to fire the turret gun.

**(c) Contacts B - deenergized.** Contacts B in the deenergized position, when the TOW mode is selected, energize the fixed forward relay (19K81), to position the gun at 0° azimuth and 0° elevation.

**(d) Contacts B - energized.** Contacts B in the energized position are open to allow the pilot TRIGGER ACTION switch to control the turret.

**z. 19K101 - Reticle Flasher Bypass Relay.**

**(1) Purpose.** To provide a steady reticle in the helmet sight prior to TRIGGER ACTION switch activation.

**(2) Function.** The sight reticle is controlled by a circuit in the turret control assembly and is designed to flash anytime the gun cannot fire. Relay 19K101 provides a steady reticle until the TRIGGER ACTION switch is pressed to transfer the reticle control to the turret control assembly. This is a 10-amp, 2-pole, socket-mounted relay.

**(3) Relay contact logic.**

**(a) Contacts A - deenergized.** Contacts A in the deenergized position provide a ground to the IFCU reticle return.

**(b) Contacts A - energized.** Contacts A in the energized position connect the IFCU reticle control to the turret control assembly.

**(c) Contacts B - deenergized.** Contacts B in the deenergized position are open.

**(d) Contacts B - energized.** Contacts B in the energized position (closed) will keep 19K101 energized until the pilot releases his TRIGGER ACTION switch. This allows the gunner reticle to flash when the pilot is firing rockets.

**aa. 19K102 - Range Enable Relay.**

**(1) Purpose.** To allow range inputs to be accepted by the IFCU.

**(2) Function.** This relay is controlled by master arm voltage. This relay opens the ground signal into the IFCU to allow a range signal to be accepted from the pilot gunner. This is a 10-amp, 2-pole, socket-mounted relay.

**(3) Relay contact logic.**

**(a) Contacts A - deenergized.** Contacts A in the deenergized position ground the super elevation signal at the IFCU.

**(b) Contacts A - energized.** Contacts A in the energized position connect the super elevation signal at the IFCU to the range high circuit in the IFCU.

**(c) Contacts B.** Contacts B are not used.

**ab. 19K106 - Wing Stores Enable Relay.**

**(1) Purpose.** This relay enables the pilot to interrupt turret fire by the gunner and to fire wing stores.

**(2) Function.** With the WPN CONTR switch in the GUNNER position, 19K106 will close. This allows the pilot TRIGGER ACTION switch to interrupt gunner turret fire. When the turret reaches the stow position it will enable the WING ARM FIRE switch. This is a 10-amp, 2-pole, socket-mounted relay.

**(3) Relay contact logic.**

**(a) Contacts A - deenergized.** Contacts A in the deenergized position allow the pilot TRIGGER ACTION switch to control the turret.

**(b) Contacts A - energized.** Contacts A in the energized position allow the pilot TRIGGER ACTION switch to interrupt the gunner action circuit and send the turret to the 0° azimuth position so that rockets can be fired.

**(c) Contacts B.** Contacts B are not used.

**ac. 20K1 - TOW Missile System Interlock Relay.**

**(1) Purpose.** To provide safety switching function if the TOW electronic power supply (EPS) fails.

**(2) Function.** This relay is energized when the TOW power supply has an output. This is a 10-amp, 4-pole, socket-mounted relay.

**(3) Relay contact logic.**

**(a) Contacts A - deenergized.** Contacts A in the deenergized position (closed) will disable the turret action circuit if TRK is selected and TCP MODE SELECT switch is in STBY TOW or ARMED position.

**(b) Contacts A - energized.** Contacts A in the energized position are open.

**(c) Contacts B - deenergized.** Contacts B in the deenergized position are open.

**(d) Contacts B - energized.** Contacts B in the energized position provide control circuit to the TOW blower thermal switch for the tailboom TOW blower.

**(e) Contacts C - deenergized.** Contacts C in the deenergized position are open.

**(f) Contacts C - energized.** Contacts C in the energized position provide a circuit from the SCA to the TSU gun flags.

**(g) Contacts D.** Contacts D are not used.

#### ad. 20K84 - TSU Track Rate Select Relay.

**(1) Purpose.** To allow the TSU to slew at a slow rate in the gun mode, when TSU high magnification is selected.

**(2) Function.** This relay is controlled by the gunner RANGE switch. This is a 10-amp, 2-pole, socket-mounted relay.

#### **(3) Relay contact logic.**

**(a) Contacts A - deenergized.** Contacts A in the deenergized position connect the weapon select circuit from the TOW control panel to the SCA.

**(b) Contacts A - energized.** Contacts A in the energized position supply 10 Vdc from the TOW control panel to the SCA.

**(c) Contacts B - deenergized.** Contacts B in the deenergized position are open.

**(d) Contacts B - energized.** Contacts B in the energized position connect the TSU gun flag light to the turret status circuit in the SCA.

#### ae. 21K1 - M-18 Power Relay.

**(1) Purpose.** To allow M-18 battery charging without arming the system.

**(2) Function.** This relay is energized anytime standby power is on and provides battery charging

voltage to the inboard wing stations for the M-18. This is a 20-amp, 3-pole, screw-terminal relay.

#### **(3) Relay contact logic.**

**(a) Contacts A - deenergized.** Contacts A in the deenergized position are open.

**(b) Contacts A - energized.** Contacts A in the energized position provide voltage from the WING STORE RH GUN circuit breaker to the right inboard wing M-18 disconnect for battery charging.

**(c) Contacts B - deenergized.** Contacts B in the deenergized position are open.

**(d) Contacts B - energized.** Contacts B in the energized position provide voltage from the WING STORE LH GUN circuit breaker to the LH inboard wing M-18 disconnect for battery charging.

**(e) Contacts C.** Contacts C are not used.

#### af. 21K2 - Jettison Control Relay.

**(1) Purpose.** To prevent jettison of inboard wing stores if lower missile launchers are installed outboard.

**(2) Function.** Relay 21K2 will open the inboard jettison circuits and route the jettison signal to the outboard stations if inboard stores are selected for jettison when lower missile launchers are installed. When the electrical connector of each lower missile launcher separates, relay 21K2 relay will deenergize and route the jettison signal to the inboard stations. This is a 10-amp, 2-pole, socket-mounted relay.

#### **(3) Relay contact logic.**

**(a) Contacts A - deenergized.** Contacts A in the deenergized position connect the pilot inboard jettison circuits to the inboard stores stations.

**(b) Contacts A - energized.** Contacts A in the energized position open the pilot inboard stores jettison circuits and send the inboard jettison signal to the outboard stores stations.

**(c) Contacts B - deenergized.** Contacts B in the deenergized position connect the gunner inboard stores jettison circuits to the inboard stores stations.

**(d) Contacts B - energized.** Contacts B in the energized position open the gunner inboard stores

jettison circuits and send the inboard jettison signal to the outboard stores stations.

**ag. 21K3 - Pilot Jettison Switch Relay.**

**(1) Purpose.** To ensure the pilot jettison signal is maintained long enough for jettison sequence completion.

**(2) Function.** When the pilot releases his JETTISON pushbutton switch, 21K3 will maintain the jettison command for one second. This is a 10-amp, 2-pole, time-delay-on-dropout relay. The time delay is 1.0 second.

**(3) Relay contact logic.**

**(a) Contacts A - deenergized.** Contacts A in the deenergized position (pins C and F) ground the pilot left and right outboard stores jettison circuits.

**(b) Contacts A - energized.** Contacts A in the energized position (pins F and B) remove the ground from the left and right outboard stores jettison circuits.

**(c) Contacts B - deenergized.** Contacts B in the deenergized position (pins D and H) are open.

**(d) Contacts B - energized.** Contacts B in the energized position (pins D and H) apply voltage to the pilot JETTISON SELECT switches.

**ah. 21K4 - Pilot Jettison Control Relay.**

**(1) Purpose.** To prevent simultaneous jettison of inboard and outboard wing stores. Inboard stores are always delayed for 0.5 second.

**(2) Function.** When the pilot presses the JETTISON switch, 21K4 relay will delay for 0.5 second and then energize and send a signal to the inboard stations to jettison stores. This is a 10-amp, 2-pole, time-delay-on-pull-in relay. The time delay is 0.5 second.

**(3) Relay contact logic.**

**(a) Contacts A - deenergized.** Contacts A in the deenergized position (pins D and H) ground the left and right inboard stores jettison circuits.

**(b) Contacts A - energized.** Contacts A in the energized position (pins D and G) open the ground and apply voltage to the inboard stores jettison circuits.

**(c) Contacts B.** Contacts B (pins C, F, and B) are not used.

**ai. 21K5 - Gunner Jettison Control Relay.**

**(1) Purpose.** To prevent simultaneous jettison of inboard and outboard wing stores. Inboard stores are always delayed for 0.5 second.

**(2) Function.** This relay delays the gunner inboard stores jettison signal for 0.5 second and then sends it to the inboard stations to jettison stores. This is a 10-amp, 2-pole, time-delay-on-pull-in relay. The time delay is 0.5 second.

**(3) Relay contact logic.**

**(a) Contacts A - deenergized.** Contacts A in the deenergized position (pins D and H) ground the left and right inboard stores jettison circuits.

**(b) Contacts A - energized.** Contacts A in the energized position (pins D and G) open the ground and apply voltage to the inboard stores jettison circuits.

**(c) Contacts B.** Contacts B (pins C, F, and B) are not used.

**aj. 21K6 - Wing Stores Disable Relay.**

**(1) Purpose.** To disable rocket fire when the TOW missile is fired and missile is in flight.

**(2) Function.** This relay prevents rocket firing from the time the left-hand grip TRIGGER is pressed until after TOW wire cut. This is a 10-amp, 2-pole, socket-mounted relay.

**(3) Relay contact logic.**

**(a) Contacts A.** Contacts A are not used.

**(b) Contacts B - deenergized.** Contacts B in the deenergized position are in the pilot WING ARM FIRE switch circuit.

**(c) Contacts B - energized.** Contacts B in the energized position open the circuit to the pilot WING ARM FIRE switch.

**ak. 21K7 - Action Disable Relay.**

**(1) Purpose.** To stow turret and stop firing during rocket fire.

(2) **Function.** The WING ARM FIRE switch energizes this relay. It will remain energized for 0.5 second after the WING ARM FIRE switch is released. This is a 10-amp, 2-pole, time-delay-on-dropout relay. The time delay is 0.5 second.

(3) **Relay contact logic.**

(a) **Contacts A - deenergized.** Contacts A (pins C and F) in the deenergized position are in the turret action circuit.

(b) **Contacts A - energized.** Contacts A (pins B and F) in the energized position open the action circuit to the turret.

(c) **Contacts B.** Contacts B (pins D, G, and H) are not used.

## 9-444. **E** UNIVERSAL TURRET SYSTEM CIRCUITRY.

### 9-446. **DESCRIPTION - UNIVERSAL TURRET SYSTEM CIRCUITRY.**

The universal turret system interfaces, by means of auxiliary equipment, with the M136 helmet Sight subsystem (HSS) and the turret control portion of the stabilized telescopic sight unit (TSU) of the M65 TOW missile subsystem. The interconnecting airframe wiring integrates the three subsystem components through the interface control unit (IFCU), electronic interface assembly, and the pilot and gunner armament control panels. For additional information pertaining to the universal turret system, refer to TM 9-1090-206 series maintenance manuals. For additional information pertaining to the M136 helmet sight subsystem, refer to TM 9-1270-212-14. For additional information pertaining to the TSU and M65 TOW missile subsystem, refer to paragraph 9-464 and TM 9-1425-473 series maintenance manuals.

## 9-446. **E** FUNCTIONAL TEST - UNIVERSAL TURRET SYSTEM CIRCUITRY.

### a. Requirements.

#### (1) Test equipment.

(a) **Auxiliary power.** Ground power unit (14).

(b) **Hydraulic.** Hydraulic ground test cart (T11).

### **WARNING**

**All weapons shall be dry fired. Dummy ammunition shall not be used.**

#### (2) Special tools.

(a) Round fire simulator (T5).

(b) Air speed simulator (T10).

### b. Preparation for Testing.

(1) **General.** Qualified armament personnel shall be present during all tests specified herein. The following tests shall be accomplished using auxiliary electrical power. (Refer to paragraph 1-51.)

#### (2) Weapon system preparation.

(a) Check all system components for proper installation.

(b) Check that the turret weapon and feeder are properly timed.

(c) Open (off) all circuit breakers.





**(3) Control switch positions.** Position the following switches as indicated:

**(a) Pilot armament control panel.**

MASTER ARM	OFF
WPN CONTR	GUNNER
WING STORE	RKT
HSS RCTL brightness knob	midpoint
RECOIL COMPEN	OFF
RANGE	SHORT

**(b) Pilot miscellaneous control panel.**

INBD JETTISON SELECT	OFF
OUTBD JETTISON SELECT	OFF

**(c) Gunner armament control panel.**

PLT ORIDE	OFF
WING STORE	RKT
RD RMNG	750
SLEW RATE	SLOW
A/S COMPEN	OFF
HSS reticle brightness knob	midpoint
TURRET DEPR LIMIT	DEPR LIMIT
RANGE	SHORT

**(d) TOW control panel.**

MODE SELECT	OFF
-------------	-----

**(4) Electrical Power.** Apply 28-volt dc external electrical power. (Refer to paragraph 1-51.)

**(5) Circuit breakers.** Engage the following circuit breakers:

**(a) DC circuit breaker panel.**

GEN-FIELD  
DC VM  
CAUT LT  
GEN BUS RESET  
INV

**(b) AC/ARMT circuit breaker panel.**

TMS PWR  
TURRET CONTR  
WPN CONTR  
WPN FIRE  
HSS PWR

REF XFMR  
SECU PWR  
WING STORE PWR  
TURRET DRIVE MOTOR  
TURRET GUN MOTOR  
TURRET STOW  
TMS BLWR  
PLT JETT  
GNR JETT

**(6) Power switch positions.** Position the following switches as shown:

ALTNR	OFF/RESET
BATTERY	RUN
NON-ESNTL BUS	MANUAL

**(7) Gunner miscellaneous panel.** Position ELEC PWR/EMER OFF switch to ELEC PWR.



**Before proceeding, clear turret area of any obstructions and warn personnel to remain on exterior of safety barrier.**

**c. Testing Procedures.**

**(1) Gunner turret control.** With test personnel in the pilot and gunner positions, connect the helmet sight linkage to the built-in test (BIT) brackets at the forward support points.

**(a)** With MASTER ARM switch on pilot armament control panel and PLT ORIDE switch on gunner armament control panel to OFF, check that there is no action or firing of any armament systems from any triggers. Check that green GUN ELEV STOWED advisory indicator is illuminated in the pilot caution panel.

**(b)** Position pilot MASTER ARM switch to STBY. Observe that pilot and gunner STBY indicators are illuminated. Also observe that green GUN ELEV STOWED advisory indicator in the pilot caution panel is not illuminated.

**(c)** Position HSS BIT switch on gunner armament control panel to BIT and check that a GO indication appears on the panel indicator.

**NOTE**

**Completion of BIT circuit requires approximately two seconds.**

(d) Check pilot and gunner HSS linkage for freedom of movement in all directions.

(e) Check that HSS reticle illumination controls on pilot and gunner armament control panels are functioning properly. Turn HSS RETICLE brightness control knob from OFF to BRT and check for corresponding change in light intensity. Move RETICLE TEST switch to TEST and check that HSS reticles are still illuminated.

(f) While holding gunner helmet sight line-of-sight (LOS) at 0 degrees elevation and 0 degrees azimuth; press left hand grip (LHG) ACTION switch on TSU and slowly rotate LOS downward. The weapon should reach lower depression limit at approximately -5 degrees. Then rotate LOS upward; the weapon should drive to the upper limit. The reticle should flash when helmet LOS is out of coincidence with the commanded gun line and when weapon reaches upper EL limit or below zero degrees elevation. Release ACTION switch.

(g) Position TURRET DEPR LIMIT switch to OFF.



**In the following steps, excessive downward movement of LOS can cause barrels to strike ground. Remove barrels or elevate helicopter 30 inches if maximum depression cannot be checked during flight test.**

(h) While holding gunner helmet sight LOS at 0 degrees elevation and 0 degrees azimuth, press LHG ACTION switch on TSU and slowly rotate helmet LOS downward. Confirm that gun barrels move past the 5-degree depression limit position. Rotate LOS upward and confirm that gun barrels move to upper elevation limit. Release ACTION switch.

(i) Move turret through total elevation, depression, and azimuth limits. Check that no binding or interference occurs.

(j) Rotate sight rapidly both in azimuth and elevation. Check that sight reticle flashes

momentarily as turret and HSS LOS are out of coincidence.

(k) Move turret against upper elevation limit and slowly through total azimuth sweep. Check that reticle flashes while turret is against upper limit in all azimuth positions.

(l) Move turret against left and right azimuth limits and slowly through total elevation sweep. Check that reticle flashes while turret is against either azimuth limit in all elevation positions. Total depression at either azimuth shall be checked during flight tests.

(m) Release ACTION switch on the LHG and check that the turret returns to stowed (upper forward) position.

(n) Return TURRET DEPR LIMIT switch to ON.

(o) Hold the sight in approximately the 0-0 position and depress ACTION switch on LHG. Attempt to fire the weapon with the gunner and pilot triggers. The weapon should not fire.

(p) Position pilot MASTER ARM switch to ARM. Check that pilot and gunner red ARMED indicators are illuminated and that pilot and gunner STBY indicators are extinguished.

(q) Press ACTION switch while holding helmet LOS at 0 degree azimuth and 0 degree elevation and move RANGE switch to MED and LONG. Check that turret elevation increases with increased range settings. Check that helmet sight reticle does not flash at SHORT, MED OR LONG range settings. Release ACTION switch. Return RANGE switch to SHORT. (Angular displacements will be measured as described in subparagraph (6) below.)

(r) Press ACTION switch and move LHG trigger on gunner TSU to the first detent, then the second. Check that turret weapon fires a short burst (approximately 1.3 seconds) at first detent and continuously at second detent.

(s) Release ACTION switch and press the trigger. The turret weapon should not fire. Press pilot ACTION switch and trigger. Check that weapon does not move or fire. Press gunner cyclic ACTION switch and trigger. Check that turret weapon does not move or fire.

**(2)** Pilot turret control. Proceed as follows to check out and test turret weapon and HSS system while under the pilot control:

**(a)** Position MASTER ARM switch to STBY.

**(b)** Position pilot WPN CONTR switch to PILOT. Check that PILOT IN CONT green indicator on gunner armament control panel illuminates.

**(c)** Press TSU LHG ACTION switch. Check that gunner helmet sight has no control of the turret.

**(d)** Press gunner cyclic grip ACTION switch. Check that gunner helmet sight has no control of the turret weapon.

**(e)** Press ACTION switch on pilot cyclic grip and check that turret weapon follows pilot helmet sight LOS in the same manner as that described for the gunner in subparagraph (1), steps (f) through (n) above.

**(f)** Position MASTER ARM switch to ARM.

**(g)** Repeat steps (q) and (r) of subparagraph (1) above, except use pilot cyclic stick ACTION switch.

**(h)** Check that pilot cyclic stick trigger fires turret weapon: a short burst (approximately 1.3 seconds) at first detent and continuously at second detent.

**(3)** Pilot override by gunner. Proceed as follows to check out function of gunner overriding pilot control of weapon:

**(a)** Position pilot override switch to PLT ORIDE.

**(b)** Check that PLT IN CONT indicator extinguishes and that gunner red ARMED indicator illuminates.

**(c)** Press gunner cyclic stick ACTION switch and check that gunner cyclic stick trigger will fire the turret weapon. The gunner HSS should control turret weapon.

**(d)** Press LHG ACTION switch and trigger. Check that turret weapon does not respond to helmet sight and gun does not fire.

**(e)** Press pilot cyclic stick action switch and trigger. Check that pilot helmet sight will not control the turret weapon and that gun does not fire.

**(f)** Position pilot MASTER ARM switch to OFF and check that both pilot and gunner red ARMED indicator lights remain on. Check that only gunner cyclic stick trigger will fire turret weapon.

**(g)** Position pilot WPN CONTR switch to GUNNER. Check that only gunner cyclic stick trigger will fire turret weapon.

**(h)** If ammunition box booster is connected during the preceding checks, counter should show less than 250 rounds (corresponding to the number of rounds fired).

**(i)** Return PLT ORIDE switch to OFF.

**(4)** Turret airspeed compensation. Check out and adjust if necessary the turret airspeed compensation operation as follows:

**(a)** Position MASTER ARM switch to STBY.

**(b)** Position MODE SELECT switch on TCP to TSU/GUN.

**(c)** Apply air pressure to the pitot system to simulate  $100 \pm 5$  knots airspeed. (Refer to TM 55-1500-204-25/1.)

**(d)** Remove the right hand fixed fairing above the turret.

**(e)** Press LHG action switch on TSU and rotate LOS of TSU to the left 90 degrees. Turret weapon must also move to the left until OUT mark on the turret decal aligns.

**(f)** Position A\ S COMPEN switch to A/ S COMPEN and observe that IN line on the turret decals align.

**(g)** Return TSU/GUN LOS to forward (0-degree) position.

**(h)** Release LHG ACTION switch.

**(i)** Position MASTER ARM switch to OFF.

**(j)** position TCP MODE SELECT switch to OFF.

(k) Position A/S COMPEN switch to OFF. Release air pressure from the pitot system.

(5) **Fixed mode firing.** Check out fixed mode firing as follows:

(a) Position pilot WPN CONTR switch to FIXED and MASTER ARM switch to STBY.

(b) Check that turret weapon moves to 0-degree elevation and 0-degree azimuth position.

(c) Press pilot cyclic grip ACTION switch. Check that turret weapon does not follow pilot helmet sight.

(d) Press ACTION switch on TSU LHG and cyclic grip ACTION switch. Check that turret weapon does not follow gunner helmet sight or TSU commands.

(e) Position MASTER ARM switch to ARM.

(f) Press pilot cyclic grip ACTION switch and trigger. Check that turret weapon fires.

(6) **Range compensation.** Check out range compensation operation as follows:

(a) Position MASTER ARM switch to STBY; MODE SELECT switch on TOW Control Panel (TCP) to TSU/GUN; HI/LO MAG switch to HI; and WPN CONTR to GUNNER.

(b) Position STOW/TRK/ACQ switch on SHC to TRK and hold TSU LOS on a fixed distant target.

(c) Press ACTION switch on LHG. Position RANGE switch to SHORT. Position MASTER ARM switch to ARM. Check that turret weapon elevation increases by approximately **9.2** milliradians.

(d) Position MASTER ARM switch to STBY. Position RANGE switch to MED. Position MASTER ARM switch to ARM. Check that turret weapon elevation increases by approximately **24.4** milliradians.

(e) Position MASTER ARM switch to STBY. Position RANGE switch to LONG. Position MASTER ARM switch to ARM. Check that turret weapon elevation increases by approximately **42.8** milliradians.

(f) Return RANGE switch to SHORT. Release ACTION switch. Position MASTER ARM switch to OFF.

(7) **Recoil compensation.**



Do not apply hydraulic power to system unless electrical power is applied.

(a) Apply  $1500 \pm 25$  psig hydraulic power to both systems.

(b) Connect Round Fire Simulator to FIRE VOLT CONNECTOR.

(c) Position RECOIL COMPEN switch to RECOIL COMPEN and power switch on SCAS control panel to ON. Engage PITCH, ROLL and YAW ENGAGE switches.

(d) Position WPN CONTR switch to GUNNER. Position MASTER ARM switch to ARM. Depress LHG ACTION switch. Rotate sight 90 degrees left. Observe turret is 90 degrees left and level. Press LHG trigger. Observe SCAS inputs to tail rotor and swashplate. Tail rotor response shall be the same as for left pedal inputs. Swashplate inputs shall be the same as for right cyclic stick (right roll swashplate).

(e) Repeat for 90 degrees right and level. Tail rotor response shall be the same as for right pedal inputs. Swashplate inputs shall be the same as for left cyclic stick (left roll swashplate).

(f) Repeat for 0 degrees and up elevation. Swashplate inputs shall be the same as for aft stick.

(g) Repeat for 0 degrees and down elevation. Swashplate inputs shall be the same as for forward stick.

(h) Open all armament switches and disengage circuit breakers. Disconnect hydraulic power cart and Round Fire Simulator.

#### 9-447. **E** TROUBLESHOOTING - TURRET SYSTEM CIRCUITRY.

**a. Airframe Circuitry and Components.** Refer to paragraph F-9 in Appendix F for wiring diagram and trace malfunctioning circuit loop, using standard

electronic troubleshooting procedures, and standard test equipment. Localize malfunctioning components and repair or replace as required.

**b. Turret System.** Refer to TM 9-1090-206 series maintenance manuals for troubleshooting procedures pertaining to the universal turret system.

**c. Helmet Sight Subsystem.** Refer to TM 9-1270-212-14 for troubleshooting procedures pertaining to the M136 helmet sight subsystem.

**d. Telescopic Sight Unit.** Refer to TM 9-1425-473 series maintenance manuals for troubleshooting procedures pertaining to the telescopic sight unit portion of the M65 TOW missile subsystem.

### **9-448. E M136 ELECTRONIC INTERFACE ASSEMBLY.**

#### **9-449. E DESCRIPTION M136 ELECTRONIC INTERFACE ASSEMBLY.**

The electronic interface assembly is a component of the M136 helmet sight subsystem that provides regulated 28 Vdc power and contains the electronic components necessary for the operation of the HSS. The electronic interface assembly is the point of integration with the interface control unit (IFCU) which interfaces the HSS and TSU sighting systems with the universal turret system. The electronic interface assembly is mounted to the rear cockpit bulkhead (see figure 9-23). The electronic interface assembly contains buffer amplifiers and circuitry required by the linkage resolvers, azimuth and elevation alignment controls and associated circuitry for boresighting each linkage assembly, and the BITE circuits and controls necessary to provide the HSS self-test capability. For additional information and maintenance procedures pertaining to the electronic interface assembly, refer to TM 9-1270-212-14.

#### **9-450. E INTERFACE CONTROL UNIT (IFCU).**

#### **9-451. E DESCRIPTION - INTERFACE CONTROL UNIT (IFCU).**

The interface control unit (IFCU) contains the signal switching, resolver, logic, and buffering circuitry necessary to interface the helmet-sight subsystem (HSS) and stabilized telescopic sight unit (TSU) with the universal turret system. The IFCU is located in the right access compartment below the wing (see figure 9-23). When the gunner selects the gun mode in the

TOW system, the computing resolver chain contained within the turret system is connected to similar resolvers located in the TSU. Elevation and azimuth commands and a range compensation function are then developed in the TSU which are returned by the IFCU to the turret system as positioning signals for the turret assembly. In this manner, as the TSU tracks the target, the turret assembly is commanded to follow the TSU line-of-sight. Operation with either the pilot or gunner helmet sight is accomplished in a like manner. The function of the IFCU is to receive signals from all three sighting units and to select the appropriate one, depending upon the mode activated by the system operator. This interchange of signals is accomplished in the IFCU with the use of relay logic. Once the sighting unit is selected, turret positioning signals are routed from the sight back through the IFCU to integrated circuit buffer amplifiers. The amplifiers are incorporated to ensure that computing accuracy in the resolver chain is maintained. In addition to the gun mode, an acquisition mode is provided in which either helmet sight positions the TSU. The acquisition mode thus allows either the pilot or the gunner to acquire a target for the TOW missile by utilizing the helmet sight. The relay logic in the IFCU also provides a dual mode capability. If the gunner has selected the TOW mode, the pilot has the capability of directing the turret assembly with the helmet sight. In addition, either helmet sight may be directing the turret assembly while the other helmet sight is used to acquire a target for the TOW missile. Pitch and roll trim resolvers within the IFCU resolve any installation misalignment existing between the TSU and the turret assembly. These resolvers are aligned during system boresighting and then locked in the corrected position. Other IFCU inputs and outputs include airspeed data for turret compensation, helmet sight reticle voltage, and a turret coincidence signal which provides an indication as to turret/sight alignment. The turret depression limit circuitry in the IFCU limits the down elevation of the turret to 5 degrees maximum to prevent damage which could result if gun strikes the ground. Depression limits is activated when gunner positions TURRET DEPR LIMIT switch from OFF to TURRET DEPR LIMIT.

#### **9-452. E CLEANING - INTERFACE CONTROL UNIT (IFCU).**

**a.** Remove moisture and loose dirt with a clean, soft cloth.

**WARNING**

**Cleaning solvent is flammable and toxic. Provide adequate ventilation. Avoid prolonged breathing of solvent vapors and contact with skin or eyes.**

b. Remove grease, fungus, and dirt with a clean, lint-free cloth dampened with dry cleaning solvent (C112).

c. Remove dirt from electrical connectors with a bristle brush.

**9-453. E INSPECTION - INTERFACE CONTROL UNIT (IFCU).**

a. Inspect IFCU case for cracks or damage.

b. Inspect electrical connectors for broken pins or cracked connector inserts.

c. Inspect IFCU for secure mounting.

**9-454. E REMOVAL - INTERFACE CONTROL UNIT (IFCU).**

a. Ensure all electrical power is OFF.

b. Remove IFCU access panel (right side, below wing).

c. Disconnect three electrical connectors from IFCU. Protect receptacles and plugs with caps or electrical tape (C121).

d. Remove mounting screws and washers, and remove IFCU from wall.

**9-455. E REPAIR - INTERFACE CONTROL UNIT (IFCU).**

a. Repair connectors, and tighten or replace loose or missing mounting screws.

b. Replace IFCU if case is damaged or defective. Evacuate removed IFCU to higher maintenance level for disposition.

**9-456. E INSTALLATION - INTERFACE CONTROL UNIT (IFCU).**

a. Position IFCU in place on wall and install mounting screws and washers.

b. Remove protective caps or electrical tape from three electrical connectors and install on IFCU.

**9-457. E LOGIC CONTROL UNIT.**

**9-458. E DESCRIPTION - LOGIC CONTROL UNIT.**

The logic control unit (LCU) is an interface unit and a component of the universal turret system. It interfaces with the turret control unit, gun control unit, SCAS armament compensation unit, and the interface control unit. The LCU is located aft of the ammunition compartment. Access to the unit is gained through the access panel located on the left side of the helicopter above the forward crosstube. SCAS compensation signals are provided by a program switch on the LCU. The program switch selects various circuit configurations in the LCU to provide for the difference in movement associated with the individual weapon that is installed (20 or 30MM). Logic command circuits in the LCU provide a torque enable signal to indicate use of the pitch, roll, and yaw signals by the SCAS system. Two 1.5 degree error detection circuits, one for azimuth and one for elevation, are provided to prevent the weapon from firing if the turret returns to normal stow while still clearing. Also, a 180 degree interlock circuit is provided to prevent or interrupt weapon firing when the turret and sight are not in normal azimuth alignment. Depression limiting circuitry is provided to prevent the turret from depressing further than a 5 degree down angle. When the turret elevation angle is changed, a resolver generates a voltage which is proportional to the sine function of that angular displacement. This signal is demodulated into a proportional linear dc voltage. The demodulation circuitry is identical to that used in the turret control assembly. The second functional section of the circuit detects the phase (direction) and amplitude (angle) of the demodulators output. When the turret direction is down and equal to or greater than 5 degrees, a transistor is energized providing a ground return for a relay coil which is powered by the helicopter electrical circuitry. This accomplishes elevation error cancellation and prevents the turret from depressing further than the 5 degree down angle. A burst length limiting circuit with burst limit override logic interfaces with the gun control unit. The program

switch on the LCU selects the proper time delay for the weapon installed. The burst limit override disables the time delay function by disconnecting the trigger signal from the timing circuit. A four input OR circuit is provided to interface the 180 degree, 1.5 degree azimuth, and turret electrical interlocks to the gun control unit. A 180 degree false coincidence circuit is provided to prevent turret latch-up when the selected sight position differs from the weapon boreline by more than 180 degrees due to rapid rotation of the helmet sight or mode switching. Other LCU circuits include a transistor inverter for the reticle, and an elapsed time indicator.

**9-459. CLEANING - LOGIC CONTROL UNIT (LCU).**

a. Remove moisture and loose dirt with a clean, soft cloth.



**Cleaning solvent is flammable and toxic. Provide adequate ventilation. Avoid prolonged breathing of solvent vapors and contact with skin or eyes.**

b. Remove grease, fungus, and dirt with a clean, lint-free cloth dampened with dry cleaning solvent (C112).

c. Remove dirt from electrical connectors with a bristle brush.

**9-460. E INSPECTION - LOGIC CONTROL UNIT (LCU).**

a. Inspect LCU case for cracks or damage.

b. Inspect electrical connectors for broken pins or cracked connector inserts.

c. Inspect LCU for secure mounting.

**9-461. E REMOVAL - LOGIC CONTROL UNIT (LCU).**

a. Ensure all electrical power is off.

b. Remove access panel aft of ammunition compartment above forward crosstube on left side of helicopter.

c. Disconnect electrical connectors from LCU. Protect receptacles and plugs with caps or electrical tape (C121).

d. Remove mounting screws and washers. Remove LCU from helicopter.

**9-462. E REPAIR - LOGIC CONTROL UNIT (LCU).**

a. Repair connectors and tighten or replace loose or missing mounting screws.

b. Replace LCU if case is damaged or defective. Evacuate removed LCU to higher maintenance level for disposition.

**9-463. E INSTALLATION - LOGIC CONTROL UNIT (LCU).**

a. Position LCU in place and install with mounting screws and washers.

b. Remove protective caps or electrical tape and connect electrical connectors to LCU.

**9-464. E M65 TOW MISSILE SUBSYSTEM CIRCUITRY.**

**9-465. E DESCRIPTION - M65 TOW MISSILE SUBSYSTEM CIRCUITRY.**

The M65 TOW missile subsystem circuitry provides the capabilities to acquire and track a target, compensate for effects of helicopter motion, launch a TOW missile, and guide the missile to the target. The telescopic sight unit (TSU) portion of the TOW missile subsystem interfaces with the universal turret system circuitry, serving as a flexible sighting unit, and also interfaces with the helmet sight subsystem for use during target acquisition. For description and additional information pertaining to M65 TOW missile subsystem components, refer to TM 55-1520-236-10 and TM 9-1425-473 series maintenance manuals. For maintenance information and procedures pertaining to M65 TOW missile subsystem components, refer to TM 9-1425-473 series maintenance manuals. For information and maintenance procedures pertaining to the interface control unit (IFCU), refer to paragraph 9-450.

**9-466. E FUNCTIONAL TEST - M65 TOW MISSILE SUBSYSTEM CIRCUITRY.**

**a. Requirements.**

**(1) Test equipment.**

**(a) Auxiliary power.** Auxiliary power unit (T14).

**(b) Hydraulic.** Hydraulic ground test cart (T11).

**WARNING**

**All weapons shall be dry fired. Only dummy ammunition with smooth cases like live ammunition shall be used.**

**(2) Special tools.** TOW simulator evaluation missile (TSEM) (T70).

**b. Preparation for Testing.**

**(1) General.** Qualified armament personnel shall be present during all tests specified herein.

**(2) Configuration.** For the purpose of this test, the universal turret will be assumed to have a 20MM weapon.

**NOTE**

**For functional test of M65 TOW missile launcher system refer to TM 9-1425-473 series maintenance manuals.**

**(3) Weapon system preparation.**

**(a)** Check all systems components for proper installation.

**(b)** Verify that the launchers are properly connected, four launchers installed, and the TSEM installed in No. 1 missile position. (See figure 9-24.)

**(c)** Open (off) all circuit breakers.

**(4) Control switch positions.** Position the following switches as indicated:

**(a)** Pilot armament control panel.

MASTER ARM	OFF
WPN CONTR	GUNNER
WING STORE	RKT

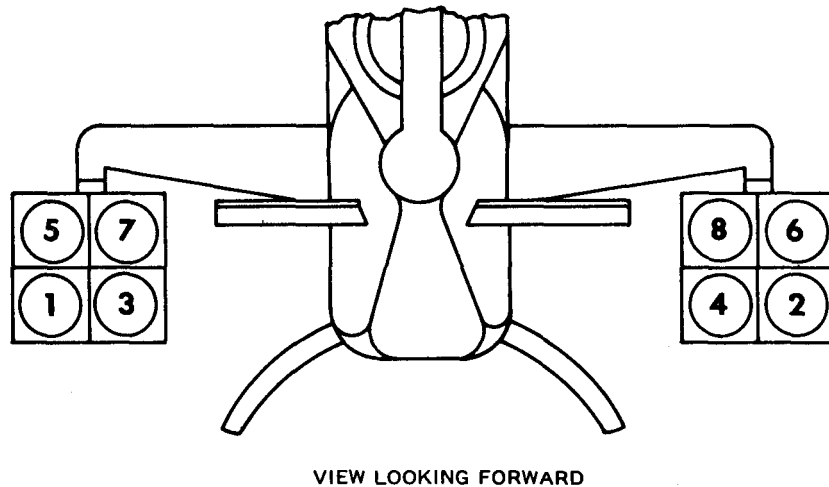

209075-150

Figure 9-24. E TOW Missile Launcher Positions



**(b) Pilot rocket control panel.**

WG ST ARM OFF

**(c) Gunner armament control panel.**

WING STORE RKT  
 TURRET DEPR LIMIT DEPR LIMIT  
 PLT ORIDE OFF  
 SLEW RATE NORM  
 A/S COMPEN A\S COMP  
 RANGE SHORT  
 RD RMNG 750

**(d) TOW control panel (TCP).**

MODE SELECT OFF  
 CAMERA OFF  
 MISSILE SELECT 1  
 EXPOSURE BRT

**(e) Sight hand control (SHC).**

STOW/TRK/ACQ STOW

**(f) Telescopic sight unit (TSU).**

FILTER SELECT LEVER CLEAR

**(5) Electrical power.** Check that the aircraft battery is connected, then apply 28-volt dc external electrical power.

**(6) Circuit breakers.** Engage the following circuit breakers:

**(a) Dc circuit breaker panel.**

GEN FIELD  
 DC VM  
 CAUT LT  
 INV  
 GEN BUS RESET

**(b) Ac circuit breaker panel.**

TURRET CONTR  
 TMS PWR  
 WPN CONTR  
 WPN FIRE  
 HSS PWR  
 REF XFMR  
 SECU PWR  
 WING STORE PWR

**(7) Power switch positions.** Position the following switches as shown:

ALTNR	OFF RESET
BATTERY	RUN
NON-ESNTL BUS	MANUAL
ELEC PWR/EMER OFF	ELEC PWR



Before proceeding, clear turret area of any obstructions and warn personnel to remain on exterior of safety barrier.



To ensure immediate control of the system, do not apply hydraulic power to system unless electrical power is applied.

**(8) Hydraulic power.** Apply 1500 ± 25 psi hydraulic power to system No. 2.

**(9) Special test equipment.** Position the following test equipment switches or controls as indicated:

TOW system evaluator missile (TSEM).

POWER	OFF
FUNCTION	LAMP TEST

**c. Testing Procedures.**

**(1) Initial system tests.** Perform the following steps for initial system tests:

**NOTE**

For this test, one technician will be required in the gunners position, one technician in the pilot position, and one technician outside the helicopter.

**(a)** Position the pilot MASTER ARM switch to STBY and WPN CONTR to GUNNER.

**(b)** Position the TCP MODE SELECT switch to TSU/GUN.

**(c)** Verify that system status indicator on TCP moves from OFF to TEST after approximately 10 seconds.

(d) Verify that within 120 seconds after TCP system status indicator reads TEST in step(c), the TCP system status indicator moves to PWR ON.

(e) Verify that all BIT indicators on the TCP are in "go" condition (black on black).

(f) Move HI/LO MAG switch on LHG to LO MAG.

(g) Move STOW/TRK/ACQ switch to TRK. Observe that TSU turret follows the inputs from SHC transducer stick and that status flag in TSU shows GUNS. Verify that gun does not follow the sight.

(h) Position TURRET DEPR LIMIT switch to OFF.



**Do not depress TSU or gun barrels during the following check if gun barrels are installed. Barrels could strike the ground with sufficient force to cause system damage.**

(i) Press ACTION switch on LHG. Observe that turret weapon follows TSU when moved through the limits with SHC transducer stick. Observe that GUNS flag in TSU sight flashes when at limit stops of the turret weapon.

#### NOTE

**Guns flag may not flash if gun turret exceeds TSU in azimuth, due to tolerance in stop location.**

(j) Release ACTION switch. Observe that turret weapon returns to STOW.

(k) Move LOS of TSU to approximately 0 degrees azimuth and elevation and press LHG ACTION switch and trigger. Observe that turret weapon will not fire.

(l) Release ACTION switch. Position pilot MASTER ARM switch to ARM.

(m) Move LOS on TSU to approximately 0 degrees azimuth and elevation and press LHG ACTION switch and trigger. Observe that turret weapon fires.

(n) Release ACTION switch and position MASTER ARM switch on pilot armament control panel to STBY.

(o) Return STOW/TRK/ACQ switch to STOW.

(p) Return TURRET DEPR LIMIT switch to DEPR LIMIT.

**(2) Telescopic sight controls.** Perform the following steps for initial system turn-on:

(a) Position MODE SELECT switch to STBY TOW on TOW control panel (TCP). Verify that TCP system status indicator remains at PWR ON.

(b) Position STOW/TRK/ACQ switch to TRK and press LHG ACTION switch. Observe that turret weapon will not follow inputs from SHC transducer stick.

(c) Release LHG ACTION switch and return STOW/TRK/ACQ switch to STOW.

(d) Position TCP MODE SELECT switch from STBY TOW to ARMED MAN. Verify that TCP system status indicator remains at PWR ON.

(e) Position MASTER ARM switch on pilot armament control panel from STBY to ARM to STBY. Verify that system status indicator on TCP moves from PWR ON to ARMED to PWR ON during this sequence.

(f) Position WPN CONTR switch on pilot armament control panel to PILOT.

(g) Position MASTER ARM switch from STBY to ARM to STBY. Verify that system status indicator on TCP remains at PWR ON during this sequence.

(h) Position WPN CONTR switch on pilot armament control panel to FIXED and repeat step (g). Return WPN CONTR switch to GUNNER.

(i) Position STOW/TRK/ACQ switch on SHC to TRK and return to STOW. Verify that system status indicator remains in the PWR ON position during this sequence.

#### NOTE

**Steps (j), (k), (l), and (m) should be done in rapid succession in order to maintain the TEST indication. Read these steps before their initiation.**

(j) Press and hold BIT pushbutton on TCP. Verify that ATTK, RDY, and GUNS flags are visible in TSU eyepiece. Verify that ascend and descend pointers and ATTK, RDY, and FIRE flags are visible on pilot steering indicator. Release BIT SWITCH after verifying the above and check that system status indicator on TCP reads TEST.

(k) Position TCP MODE SELECT switch from ARMED MAN to OFF to ARMED MAN in less than 5 seconds. Verify that system status indicator on TCP moves from TEST to OFF to TEST. There should be no 10-second delay from OFF to TEST on TCP system status indicator.

(l) With system status indicator reading TEST from step (k), position STOW/TRK/ACQ switch on sight hand control to TRK and return it to STOW. Verify that system status indicator cycles from TEST to PWR ON to TEST during this sequence.

(m) With system status indicator reading TEST from step (l), position MASTER ARM switch on pilot armament control panel from STBY to ARM to OFF. Verify that system status indicator on TCP moves from TEST to ARMD to OFF during this sequence.

(n) Position pilot MASTER ARM switch to ARM, the STOW/TRK/ACQ switch on SHC to TRK and position TCP MODE SELECT switch to STBY TOW.

(o) Position TSU optics to HI MAG using HI/LO MAG switch on TSU LHG grip. Observe that TSU is now in HI MAG mode.

(p) While holding ACTION switch, use SHC stick to drive TSU from stop to stop horizontally and vertically. Verify that TSU can be driven stop to stop horizontally in less than 50 seconds and vertically in less than 30 seconds.

(q) Position TSU optics to LO MAG using HI/MAG switch on TSU LHG grip.

(r) Use SHC stick to drive TSU to stop, horizontally and vertically. Verify that TSU can be driven from stop to stop horizontally in less than 3 seconds and vertically in less than 2 seconds. Release ACTION switch.

(s) Position TSU OPTICS to HI MAG using HI/LO MAG switch and position TCP MODE SELECT switch to TSU GUN.

(t) Use SHC stick to drive TSU from stop to stop horizontally and vertically. Verify that TSU can be driven stop to stop horizontally in 8 seconds and vertically in 4 seconds.

(u) Return STOW/TRK/ACQ switch to STOW.

### (3) Helmet sight tracking.

(a) Position MASTER ARM switch on pilot panel to STBY.

(b) Connect helmet sight linkages to the BUILT-IN TEST (BIT) brackets.

(c) Position HSS BIT switch on gunner control panel to BIT and release. Check that a GO indication appears on HSS test indicator.

### NOTE

Completion of BIT circuit requires approximately two seconds.

(d) Connect pilot and gunner linkages to their respective helmets and check for freedom of movement in all directions. Adjust helmet sight reticle on helmet until full reticle pattern can be seen.

(e) Position STOW/TRK/ACQ switch to TRK. Press and hold PHS ACQ and check that gunner helmet sight reticle retracts automatically. Check that TSU follows pilot helmet sight as it is aimed to left, right, up, and down. Release PHS ACQ switch.

(f) If installed, return gunner helmet sight reticle to the down position.

(g) Hold STOW/TRK/ACQ switch in ACQ position. Verify that TSU follows gun helmet sight as it is aimed to left, right, up, and down. Release STOW/TRK/ACQ switch and check that gunner helmet sight reticle retracts.

(h) Position STOW/TRK/ACQ switch to STOW.

(4) Pilot steering indicator commands and constraints test. Pilot steering commands on the PSI are a function of TSU AZ and EL gimbal angles. PSI azimuth steering is biased plus 0.75 degree left for right missiles. Logic prevents preferring a TOW missile until LOS rate, gimbal angle, attack logic, launcher

position status, and roll constraint requirements are satisfied.

(a) Position the pilot MASTER ARM switch to ARM.

(b) Position the TCP MODE SELECT switch to ARMED MAN.

(c) Position SHC STOW/TRQ/ACQ switch to TRK and HI/LO MAG switch to HI. Select missile number 1.

(d) Depress LHG ACTION switch.

(e) Using the SHC, adjust TSU position for azimuth and elevation LOS to be zero.

(f) Verify the PSI azimuth needle is approximately one-third from center to right when AZ and EL LOS is zero.

(9) Select missile number 2.

(h) Adjust TSU position for azimuth and elevation LOS to be zero and depress LHG ACTION switch.

(i) Verify the PSI azimuth needle is approximately one-third from center to the left when the AZ and EL LOS is zero.

(j) Move TSU LOS through azimuth and elevation; observe that PSI indicates the movement of TSU LOS.

(k) Release LHG ACTION switch.

(l) Return STOW/TRK/ACQ switch to STOW.

**(5) Launcher/TSU alignment and slaving test.**

(a) Apply hydraulic power to helicopter. Position TCP MODE SELECT switch to ARMED MAN and MASTER ARM switch to ARM on pilot armament control panel. Position TSU HI/LO MAG switch to HI.

(b) Select missile number 1 on TCP. Verify that missile status indicator on TCP for missile number 1 reads MSL.

(c) Set STOW/TRK/ACQ switch on SHC to TRK and track TSU to 0 degrees azimuth and 0 degrees elevation. Verify pilot L/R TOW indicator indicates left side.

(d) Depress and hold ACTION switch on LHG. Verify that left launcher is slaving to TSU LOS in elevation.

(e) Drive TSU up slowly in elevation until elevation needle on PSI falls outside the inner rectangle. Verify that PSI RDY flag disappears.

(f) Recenter the elevation needle and verify reappearance of the RDY flag. Drive TSU down until the elevation needle falls below the inner rectangle and verify that RDY flag disappears.

(g) Press and hold ACTION switch on LHG and drive TSU with SHC stick vertically from stop-to-stop. Verify that right launcher does not move and that left launcher follows vertical motion of TSU within the limits of the launchers mechanical stops.

(h) With TSU at the lower stop, release LHG ACTION switch and verify that after a short delay (0.5 second), the launcher moves back to its stowed position.

(i) Select missile number 2 and repeat steps (a) through (h), verifying action of the right launcher.

**(6) Armament control tests.** Operation during the preparation for launch and guidance of a missile shall be verified as follows:

**(a) Pilot turret control and firing while in the TOW mode.**

**1** Position WPN CONTR switch on pilot armament control panel to PILOT and MASTER ARM switch to ARM.

**2** With MODE SELECT switch on TCP in any of the TOW modes (STBY TOW, ARMED MAN, or ARMED AUTO) and STOW/TRK/ACQ switch on SHC in either TRK or STOW, check that gunner PILOT INCONT green indicator is illuminated and that pilot can fire the turret weapon while using his helmet sight.

**3** Position the WPN CONTR switch to GUNNER and repeat step 2.

**(b) TSEM operating procedure.** Installation and operation of the TSEM shall be as follows:

**1** After loading the TSEM into launcher and lowering the arming lever, position POWER

switch to ON. Check that POWER light and SHEAR PIN light illuminate.

**2** Position SELF TEST switch to AUTO and press RESET button.

**3** When TSEM is fired in a normal sequence, the following will be observed on rear panel of the TSEM:

**a** The START and WIRE SIGNAL AMPL lights illuminate simultaneously, then PREFIRE and -12 lights illuminate in sequence.

**b** The YAW, PITCH, FIRE, MSL GONE, and ZERO lights illuminate in sequence.

**c** The WIRE CUT and SQUIB DISC lights then illuminate and WIRE SIGNAL AMPL light extinguishes.

**d** The previously mentioned lights will remain illuminated until RESET button is depressed. Exception: the SHEAR PIN light will remain illuminated until launcher arming lever is raised.

NOTE

In the first simulated firing following TSM turn on, or following a BIT sequence, the PITCH and YAW balance lights may not illuminate. This should not be interpreted as an abnormal firing sequence unless the PITCH and YAW lights fail to illuminate on successive firings.

**4** At the end of test, or when use of TSEM is not called for in a test, or when TSEM is to be down loaded, position POWER switch to OFF. (An unpowered TSEM loaded into a launcher will not affect the outcome of tests not requiring the TSEM.)

(c) Manual missile selection and firing.

NOTE

Shearpin depression limits must be within tolerance for the launcher to be acceptable for firing. Both pods of all launchers must be verified. To avoid a double effort, check the upper outboard position last.

**1** Move launcher armament control handle to up position.

**2** Turn TSEM to ON and press reset button.

**3** Connect TSEM power cable to TSEM and to DC power connector located in the ammunition bay.

**4** Position TSEM mode select switch to AUTO and power switch to ON.

**5** Press TSEM RESET switch and verify that power lamp is illuminated.

**6** Rotate mode select switch to LAMP TEST and verify that all TSEM lamps illuminate.

**7** Rotate mode select switch to SP "GO" and verify that shearpin lamp illuminates.

**8** Rotate launcher armament control handle to ARMED position and secure it with the captive locking pin. Verify that shearpin lamp goes out.

**9** Rotate TSEM mode select switch to SP "GO" and verify that shearpin lamp illuminates. If shearpin lamp does not illuminate, this launcher position should not be used until readjustment and verification of shearpin depression is accomplished.

**10** Push RESET button.

**11** Position MASTER ARM switch on pilot armament control panel to ARM.

**12** Position MODE SELECT switch on TCP to ARMED MAN. Verify that MISSILE SELECT switch is on missile position No. 1.

**13** Verify that missile status indicator on TCP for missile No. 1 indicates MSL.

**14** Set STOW/TRK/ACQ switch on SHC to TRK.

**15** Set HI/LO MAG switch on LHG to HI.

**16** Verify the appearance of ATTK flag in the eyepiece of TSU and on PSI.

NOTE

Within constraint limitations means that the elevation and azimuth needles are within the inner rectangle and the ascend and descend pointers are not visible.

**1.7** While observing PSI, maintain maneuver indicators within constraint limitations using SHC tracking stick. Verify that RDY flags are visible on PSI and in the eyepiece of TSU.

**1.8** Position TSEM mode select switch to MSL GONE. Verify that RDY flags disappear on PSI and in the eyepiece of TSU. Position TSEM mode select switch to AUTO.

#### NOTE

**The ACTION and trigger switch on the pilot cyclic grip will be depressed and held through steps 19 through 21. Read all of these steps before depression of the trigger.**

**1.9** Hold pilot helmet sight at 0 degree elevation and 0 degree azimuth and press pilot cyclic stick ACTION and trigger switch. Verify that turret weapon fires.

**2.0** Press the trigger and ACTION switch on LHG. Verify that turret weapon firing is interrupted.

**2.1** Verify that turret weapon resumes firing after a time delay of 2.8 TO 3.2 seconds. Release pilot cyclic grip trigger and ACTION switch.

**2.2** Verify the appearance of FIRE flag on PSI. The FIRE flag will disappear at completion of firing sequence, approximately 23 seconds.

**2.3** Using the TSEM, verify that a proper firing sequence takes place. Lights on TSEM will show proper sequence according to subparagraph (b) 3 above.

**2.4** Verify that indicator for missile No. 1 on TCP switches from MSL to barber pole pattern.

**2.5** When FIRE flag disappears, press RESET button on TSEM and verify that indicator for missile No. 1 on TCP again indicates MSL.

**2.6** Press and hold ACTION switch on LHG and drive TSU LOS out of constraints in elevation. Pull trigger to confirm missile will not fire.

**2.7** Press CONST OVRD switch on SHC. Verify appearance of ATTK flag in the eyepiece of TSU and on PSI. RDY flag should not appear.

**2.8** Momentarily press trigger on LHG. The ACTION switch may be released with the trigger switch.

**2.9** Reset TSEM and with TSU LOS in constraints, pull ACTION switch and trigger switch on LHG. Push gunner wire cut switch and observe wire cut indicator on TSEM.

**3.0** Repeat step 29 using pilot wire cut button.

**3.1** Remove TSEM from missile position No. 1, cycle (install) the TSEM through the remaining missile positions, and repeat steps 3 through 31 for each position selected.

#### (d) Automatic selection and firing.

**1** Install TSEM in missile position No. 1.

**2** Set mode select switch on TSEM to AUTO.

**3** Set MASTER ARM switch on pilot armament control panel to ARM. Set MODE SELECT switch on TCP to ARMED AUTO.

**4** Set STOW/TRK/ACQ switch on SHC to T R K .

**5** Set HI/LO MAG select switch on LHG to HI.

**6** Press LHG ACTION switch and, by observing PSI, maintain indications within maneuver constraints.

**7** Momentarily press the trigger on LHG. Note completion of firing sequence by observing a loss of the FIRE flag on PSI. Verify that TSEM firing sequence is in accordance with subparagraph (b)3 above.

**8** Return STOW/TRK/ACQ switch to STOW.

**9** Check that MISSILE SELECT switch on TCP has automatically selected missile No. 2 or the next available missile. Check pilot L-R TOW indicator.

**10** Repeat steps 5 through 9 for all remaining missile positions. Verify that PSI and TCP indications are normal and verify TSEM firing sequence.

**1.1** For missile position No 8, set TCP CAMERA switch to AUTO. Verify that camera operations (if available) start when the LHG trigger is pressed and stop with the loss of fire flag indication on PSI.

**1.2** Position gunner PLT ORIDE switch to PLT ORID. Observe that TCP system status indicator moves to OFF.

**1.3** Turn TSEM off.

**1.4** Place pilot MASTER ARM to OFF, PLT ORIDE to OFF, and TCP MODE SELECT switch to OFF.

**1.5** Turn CAMERA (if available) switch to OFF.

**d. Conclusion of Tests.** Upon completion of the preceding tests, de-energize and disconnect auxiliary power unit and hydraulic ground test cart. Remove TSEM from launcher.

## 9-467. **E** TROUBLESHOOTING - M65 TOW MISSILE SUBSYSTEM CIRCUITRY.

**a. Airframe circuitry and components.** Refer to paragraph F-9 in Appendix F for wiring diagram and trace malfunctioning circuit loop, using standard electronic troubleshooting procedures and standard test equipment. Localize malfunctioning components and repair or replace, as required.

**b. M65 TOW missile subsystem.** Troubleshooting of the M65 TOW missile subsystem is accomplished during BIT (built-in test) procedures and also by use of Test Set, Guided Missile System (TSGMS). Refer to TM 9-1425-473 series maintenance manuals for troubleshooting procedures.

## 9-468. **E** SERVO ELECTRONIC CONTROL UNIT (SECU).

### 9-469. **E** DESCRIPTION - SERVO ELECTRONIC CONTROL UNIT (SECU).

The servo electronic control unit (SECU) provides regulated power and contains signal switching, servo amplifier, logic, and buffering circuitry necessary to align the pitch angle of the TOW missile launchers with the pitch angle of the line-of-sight (LOS) of the telescopic sight unit (TSU). Slaving of the two pitch angles ensures that the TOW missile will reliably enter the field of view of the infrared receiver of the

TSU. The TOW missile can be guided to target only if the initial launch thrust positions the missile within this field of view. During the attack mode, when the gunner selects a missile for firing, the launcher containing the selected missile is activated. Upon activation, the SECU initial command drives the launcher up. Angular position signals from the TSU resolver are routed to the SECU, processed through buffer amplifier stages, then applied to the respective launcher resolver. The launcher resolver output provides position feedback to the servo amplifier loop, and the accelerometer provides launcher acceleration feedback to the servo amplifier loop. The servo amplifier output to the hydraulic actuator servo coil allows the hydraulic actuator to change the pitch angle of the activated launcher when hydraulic pressure is provided to the actuator. The SECU also has a detector circuit which decreases the servo amplifier gain when the launcher approaches the mechanical elevation stop at either extreme. Hydraulic pressure is applied to the activated launcher through the hydraulic solenoid valve and the launcher pitches from stow position to the correct pitch angle relative to the TSU LOS. When fired, the missile is launched into the field of view of the infrared receiver, and wire transmitted command signals from the M65 guidance and command functional group steers the missile along the TSU LOS. After launch, the SECU activate signal ceases and the launcher is returned to stow position. The hydraulic solenoid is turned off after a delay of 1.5  $\pm$ 0.75 seconds. The SECU is located just aft of the ammunition compartment (figure 9-23).

## 9-470. **E** CLEANING - SERVO ELECTRONIC CONTROL UNIT (SECU).

**a.** Remove moisture and loose dirt with a clean, soft cloth.

### **WARNING**

**Cleaning solvent is flammable and toxic. Provide adequate ventilation. Avoid prolonged breathing of solvent vapors and contact with skin or eyes.**

**b.** Remove grease, fungus, and dirt with a clean, lint-free cloth dampened with dry cleaning solvent (C112).

**c.** Remove dirt from electrical connectors with a bristle brush.

**9-471. E INSPECTION - SERVO ELECTRONIC CONTROL UNIT (SECU).**

- a. Inspect SECU case for cracks or dents.
- b. Inspect SECU for secure mounting.
- c. Inspect electrical connectors for broken pins or cracked inserts.
- d. Inspect printed wiring assemblies for cracked, broken, loose or missing hardware and components; burned components and wiring; cracked, chipped, or broken wiring board.

**9-472. E REMOVAL - SERVO ELECTRONIC CONTROL UNIT (SECU).**

- a. Ensure all electrical power is OFF.
- b. Open left ammo compartment door just forward of wing.
- c. Remove access panel on aft ammo compartment bulkhead.
- d. Disconnect electrical connectors from SECU. Protect receptacles and plugs with caps or electrical tape (C121).
- e. Remove mounting screws and washers securing SECU to structure and remove SECU.
- f. Loosen two screw assemblies on front of SECU. Open door assembly and slide printed wiring assemblies out, if required.

**9-473. E REPAIR SERVO ELECTRONIC CONTROL UNIT (SECU).**

- a. Repair connectors, and tighten or replace loose or missing mounting screws.
- b. Replace SECU if case is damaged or defective. Evacuate removed SECU to higher maintenance level for disposition.
- c. Replace printed wiring assemblies as required.

**9-474. E INSTALLATION - SERVO ELECTRONIC CONTROL UNIT (SECU).**

- a. Position SECU in place and secure with mounting screws and washers.
- b. Remove protective caps or electrical tape from connectors and connect to respective receptacles on SECU.

- c. Close and secure access panel.
- d. Close left ammo compartment door.
- e. Install printed wiring assembly in SECU case. Close door and fasten two screw assemblies.

**9-475. E WING STORES ARMAMENT SYSTEMS CIRCUITRY.**

**9-476. E DESCRIPTION - WING STORES ARMAMENT SYSTEM CIRCUITRY**

The wing stores armament systems consist of the XM138 rocket management subsystem circuitry, XM18 minigun circuitry, and wing stores jettison circuitry.

**9-477. E XM138 ROCKET MANAGEMENT - SUBSYSTEM CIRCUITRY.**

**9-478. E DESCRIPTION - ROCKET MANAGEMENT SUBSYSTEM CIRCUITRY.**

The rocket management subsystem circuitry enables the pilot to determine the number of rockets-on-board before and after firing, select the warhead and fuze type, set the fuze to compensate for forest canopy or bunker cover thickness to be penetrated, select the rate at which the rockets will be fired, select singles, pairs, or quads, select the total number of rockets to be fired, select the range in meters, and to launch the rockets from rocket launchers mounted on any or all of the four wing stations. With the systems armed, rockets may be launched by pressing either the pilot WING ARM FIRE switch or gunner WING ARM FIRE switch (when in PLT ORIDE mode).

**9-479. E FUNCTIONAL TEST-ROCKET MANAGEMENT SUBSYSTEM CIRCUITRY.**

The following functional test of the XM138 rocket management system (RMS) is designed to be performed using the RMS on-board built-in test (BIT) (figures 9-25 and 9-26).

**WARNING**

**Ensure no live ammunition is present in any of the armament systems.**

- a. Open all circuit breakers and place all switches to their OFF or de-energized positions.



b. Connect a 28 Vdc external power source to helicopter external power receptacle and energize power source.

c. Place pilot MASTER ARM switch in STBY position.



d. Press the pilot RMS display unit TEST switch. The RMS BIT test will perform two routines when the TEST switch is pressed.

(1) The first routine is a digital display test and checks the display segments by lighting all segments and displaying a lighted eight (8) in all eight positions of the RND REM Panel on the pilot display unit (DU). The RMS BIT will identify a fault during the first routine by displaying a number less than eight (8) in the position containing the fault (figure 9-25).

(2) The second routine is a line replaceable unit (LRU) fault identification and location test which automatically follows the first routine. This test provides for the detection and isolation of any LRU (DU and four operations units) malfunction and non-compliant verification of LRU functions. Test results are visually displayed on the RND REM panel of the pilot display panel. If all LRUs are functioning properly as determined by the test routine the number seven (7) will be displayed for each of the five LRUs (figure 9-26). A malfunction or non-complaint of any LRU will cause the associated digital display to be blanked indicating the LRU should be replaced.

c. The BIT test may be performed at any time but ONLY if the MASTER ARM switch is in the STBY position. Switching to the ARM position will override the TEST switch and terminate any test in progress, returning the system to normal operation.

f. An additional verification of the defective LRU will be the activation of the equipment status indicator flag on the malfunction LRU.

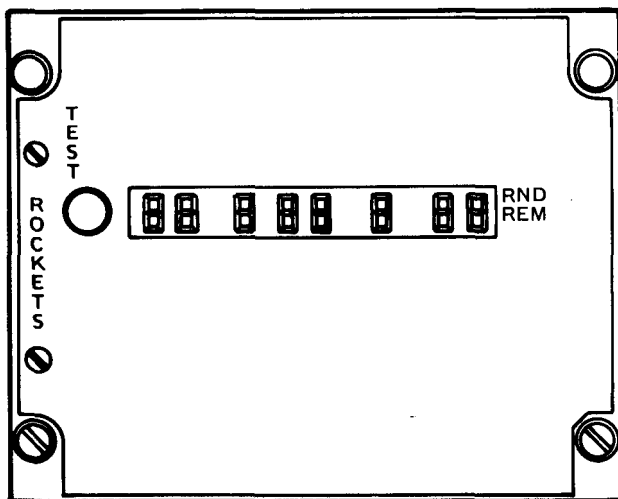

Figure 9-25. E DU Digital Display Test

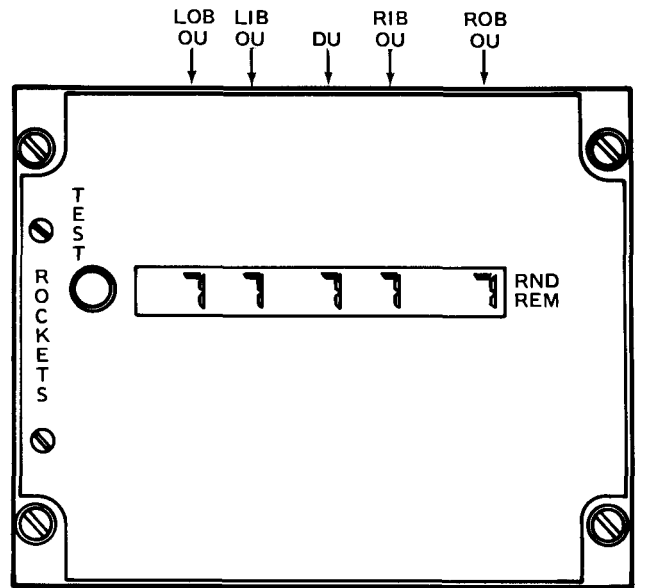

Figure 9-26. E LRU Fault Identification and Location Test

(1) The equipment status indicator flags permit the last LRU status to be displayed after primary power outages or after primary power has been removed.

(2) The equipment status indicators are magnetic-latching and mechanically resettable.

### 9-480. E TROUBLESHOOTING - XM138 ROCKET MANAGEMENT SUBSYSTEM CIRCUITRY.

#### NOTE

A filter (21A12) is installed between airframe wiring and display unit to prevent excessive noise in fm radio system. If a noise problem exists in fm radio system, turn RMS off to determine if filter is defective. Replace filter if required.

a. Airframe Circuitry and Components. Refer to paragraph F-9 in Appendix F for wiring diagram and trace malfunctioning circuit loop using standard electronic troubleshooting procedures and standard test equipment. Localize malfunctioning components and repair or replace, as required.

b. XM138 Rocket Management Subsystem. Troubleshooting of the XM 138 rocket management subsystem is accomplished during BIT (built-in-test) procedure.

**9-481. E OPERATIONS UNITS (OU).**

**9-482. E DESCRIPTION - OPERATIONS UNITS (OU).**

The operations units receive electrical command signals from the integrated control and display unit. The operations unit evaluates the information and provides the proper signals to set the fuzes on the rockets for desired running time and to provide power for the electronic circuitry.

**9-483. E CLEANING - OPERATIONS UNITS (OU).**

a. Remove moisture and loose dirt with a clean, soft cloth.



**Cleaning solvent is flammable and toxic, Provide adequate ventilation. Avoid prolonged breathing of solvent vapors and contact with skin or eyes.**

b. Remove grease, fungus, and dirt with a clean, lint-free cloth dampened with dry cleaning solvent (C112).

c. Remove dirt from electrical connectors with a bristle brush.

**9-484. E INSPECTION - OPERATIONS UNITS (OU).**

- a. Inspect OU case for cracks or damage.
- b. Inspect electrical connector for damaged pins and cracked connector inserts or hood.
- c. Inspect OU for secure mounting.

**9-485. E REMOVAL - OPERATIONS UNITS (OU).**

- a. Insure all electrical power is **off**.
- b. Remove OU access panel(s) (Outboard and inboard leading edge access panels on the left and right wing).

c. Disconnect two electrical connectors from each OU. Protect receptacles and plugs with caps or electrical tape (C121).

d. Remove four mounting bolts and washers to remove the OU from the wing leading edge bulkhead.

**9-486. E REPAIR - OPERATIONS UNITS (OU).**

a. Repair connectors, and tighten or replace loose or missing mounting or assembly screws or bolts.

b. Replace OU if case is damaged or defective. Evacuate removed OU to next higher echelon for repair or disposition (TM 9-1270-217-13 & P).

**9-487. E INSTALLATION - OPERATIONS UNITS (OU).**

a. Position OU on the wing leading edge bulkhead and install mounting bolts and washers.

b. Remove protective caps or electrical tape from two electrical connectors and install on OU.

**9-488. E XM18 MINIGUN CIRCUITRY.**

**9-489. E DESCRIPTION - XM18 MINIGUN CIRCUITRY.**

The XM-18 minigun circuitry enables the pilot or gunner (when in PLT ORIDE mode) to select and fire either or both XM-18 miniguns mounted on inboard wing stations. With the system armed, either or both miniguns may be fired by pressing either the pilot WING ARM FIRE switch or gunner WING ARM FIRE switch (when in PLT ORIDE mode).

**9-490. E FUNCTIONAL TEST - XM18 MINIGUN CIRCUITRY.**

The following functional test of the XM18 minigun circuitry is designed to be performed using a test set as indicated in figure 9-27, or a suitable equivalent.



**Ensure no live ammunition is present in any of the armament systems.**

a. Open all circuit breakers and place all switches to their OFF or de-energized positions.

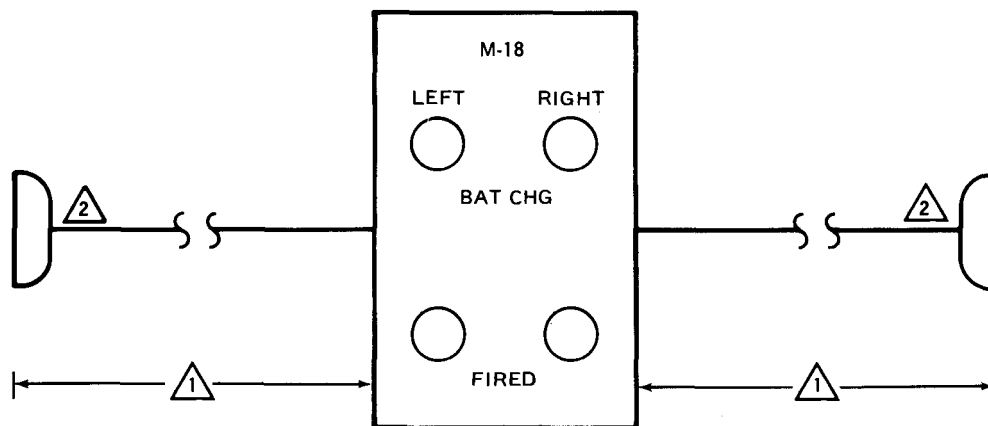

(a.) Face of Test Panel

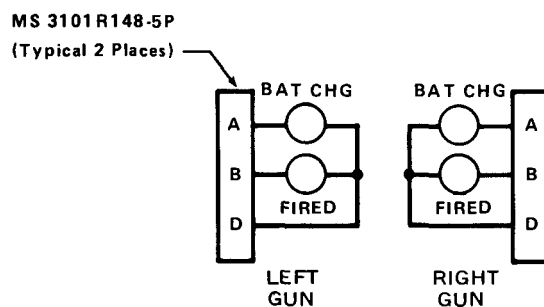

(b.) Schematic Diagram

- NOTES:
- Cable length as required.
  - Connectors to mate with 21A10P1 and 21A11P1.

209475-510

Figure 9-27. **E** XM18 Minigun Circuitry Test Panel

b. Connect the two XM18 test set cables to connectors (21A10P1 and 21A11P1) at inboard wing stores disconnect area in wings on the helicopter.

c. Connect a 28 Vdc external power source to helicopter external power receptacle and energize power source.

d. Close WPN CONT, RH MINIGUN, and LH MINIGUN circuit breakers.

e. Place WPN CONTR switch on pilot ARMT panel in PILOT position. Check that no lights are illuminated on the test set.

f. Perform steps 1 through 15 in the XM18 minigun checkout chart, table 9-37.

g. Place WPN CONTR switch on pilot ARMT panel in GUNNER position.

h. Perform steps 1 through 15 in the XM18 minigun checkout chart, table 9-37.

i. With the turret gun installed and operational, position turret full left and perform steps 7, 8, 11, 12, 13, and 15 in the XM18 minigun checkout chart, table 9-37. No FIRED light shall illuminate.

j. With the turret gun installed and operational, position turret full right and perform steps 7, 8, 11, 12, 13, and 15 in the XM18 minigun checkout chart, table 9-37. No FIRED light shall illuminate.

Table 9-37. **E** XM18 Minigun Checkout Chart

Step	Pilot WING STORE Switch	Gunner WING STORE Switch	Pilot WING FIRE Switch	Gunner WING FIRE Switch	Pilot ORIDE Switch	MASTER ARM Switch	Test Set BAT CHG Lights	Test Set FIRED Lights
1	GUN	either			OFF	STBY	on	off
2	GUN	GUN	fire		OFF	STBY	on	off
3	GUN	GUN		fire	OFF	STBY	on	off
4	GUN	GUN	fire		OFF	OFF	on	off
5	GUN	GUN		fire	OFF	OFF	off	off
6	GUN	RKT	fire release		OFF	ON	off	on off
7	GUN	GUN	fire release		OFF	ON	off	on off
8	RKT	GUN	fire		OFF	ON	off	off
9	GUN	GUN	fire		ON	ON	off	off
10	GUN	RKT	fire		ON	ON	off	off
11	RKT	GUN		fire release	ON	ON	off	on off
12	GUN	GUN		fire release	ON	ON	off	on off

Table 9-37. **E** XM18 Minigun Checkout Chart (Cont)

Step	Pilot WING STORE Switch	Gunner WING STORE Switch	Pilot WING ARM FIRE Switch	Gunner WING ARM FIRE Switch	Pilot ORIDE Switch	MASTER ARM Switch	Test Set BAT CHG Lights	Test Set FIRED Lights
13	GUN	GUN		fire release	OFF	ON	off	on off
14	GUN	RKT		fire	ON	ON	off	off
15	RKT	GUN		fire release	OFF	ON	off	on off

**9-491. E TROUBLESHOOTING - XM18 MINIGUN CIRCUITRY.**

Refer to paragraph F-9 in Appendix F for wiring diagram. Use Table 9-38 and perform checks as necessary to isolate trouble. In the following table,

tripped circuit breakers are omitted from indications of trouble. Such trouble is usually easily detected and corrected. Broken wiring is always a probable cause of circuit malfunction or failure and has not been included.

**NOTE**

Before you use this table, be sure you have performed all normal operational checks. If you have a malfunction which is not listed in this table, notify the next higher level of maintenance.

Table 9-38. **E** Troubleshooting XM-18 Minigun Circuitry.

**CONDITION**

**TEST OR INSPECTION**

**CORRECTIVE ACTION**

1. With switch breakers on AC/ARMT circuit breaker panel in WPN FIRE, LH GUN, and RH GUN positions, MASTER ARM switch in ARM, and WING STORE switch in GUN, XM18 miniguns do not fire when pilot WING ARM FIRE switch is pressed.

STEP 1. Check for defective wiring.

If defective, repair wiring.

STEP 2. Check for defective master arm relay (19K31).

If defective, replace relay (paragraph 9-16).

Table 9-38. **E** Troubleshooting XM-18 Minigun Circuitry (Cont)

**CONDITION**

**TEST OR INSPECTION**

**CORRECTIVE ACTION**

STEP 3. Check for defective WING STORE switch.

**If defective, replace switch (paragraph 9-16).**

STEP 4. Check for defective WING ARM FIRE switch on pilots cyclic stick.

**Handle in accordance with instructions pertinent to the cyclic stick (paragraph 11-40).**

- 2.** With switch breakers on AC/ARMT circuit breaker panel in WPN FIRE, LH GUN, and RH GUN, MASTER ARM switch in ARM, and WING STORE switch in GUN, one XM18 minigun fires, but the other does not fire.

STEP 1. Check for defective ground connection to airframe on the side which does not fire.

**If defective, repair ground connection.**

STEP 2. Check for defective wiring.

**If defective, repair wiring.**

STEP 3. Check for defective wing disconnect connector (21J1-21P1 or 21J2-21P2) on the side which does not fire.

**If defective, replace connector (paragraph 9-16).**

STEP 4. Check for defective LH GUN or RH GUN switch breaker which controls the side that does not fire.

**If defective, replace circuit breaker (paragraph 9-23).**

- 3.** With switch breakers on AC/ARMT circuit breaker panel in LH GUN and RH GUN, TURRET PWR circuit breaker closed, PILOT ORIDE switch in PILOT ORIDE, and WING STORE switch in GUN, neither XM18 minigun fires when WING ARM FIRE switch on gunners cyclic stick is pressed.

STEP 1. Check for defective wiring.

**If defective, repair wiring.**

STEP 2. Check for defective TURRET CONTR circuit breaker.

**If defective, replace circuit breaker (paragraph 9-23).**

STEP 3. Check for defective WING ARM FIRE switch on gunners cyclic stick.

**Handle in accordance with instructions pertinent to the cyclic stick (paragraph 11-40).**



Table 9-38. **E** Troubleshooting XM-18 Minigun Circuitry (Cont)**CONDITION****TEST OR INSPECTION****CORRECTIVE ACTION**

STEP 4. Check for defective connector (21A9P1), (21A8P1), (21J1-21P1), (21J2-21P2).

**If defective, replace connector (paragraph 9-16).**

STEP 5. Check for defective turret system circuitry.

**Refer to TM9-1090-206 series maintenance manuals.**

4. With TURRET CONTR circuit breaker and minigun switch breakers in LH GUN and RH GUN positions, PILOT ORIDE switch positioned to PILOT ORIDE, and WING STORE switch in GUN position, one XM18 minigun fires, but the other does not fire when gunners WING ARM FIRE switch is pressed.

STEP 1. Check for defective wiring.

**If defective, repair wiring.**

STEP 2. Check for defective TURRET CONTR circuit breaker.

**If defective, replace circuit breaker (paragraph 9-23).**

STEP 3. Check for defective WING ARM FIRE switch on gunners cyclic stick.

**Handle in accordance with instructions pertinent to the cyclic stick (paragraph 11-40).**

STEP 4. Check for defective connector (21A10P1), (21A11P1), (21J1-21P1), (21J2-21P2).

**If defective, replace connector (paragraph 9-16).**

STEP 5. Check for defective turret system circuitry.

**Refer to TM 9-1090-206 series maintenance manuals.**

### 9-492. **E** WING STORES JETTISON CIRCUITRY.

### 9-493. **E** DESCRIPTION - WING STORES JETTISON CIRCUITRY.

The wing stores jettison circuitry enables the pilot to select wing station weapons (inboard or outboard) to be jettisoned in an emergency situation. Selected wing station weapons are jettisoned by pressing the pilot or gunner WING STORES JETTISON switch.

### 9-494. **E** FUNCTIONAL TEST-WING STORES JETTISON CIRCUITRY.

The functional test of the wing stores jettison circuitry is designed to be performed using a test set as indicated in figure 9-28, or equivalent.

- a.** Open all circuit breakers and place all **switches** to their OFF or de-energized positions.

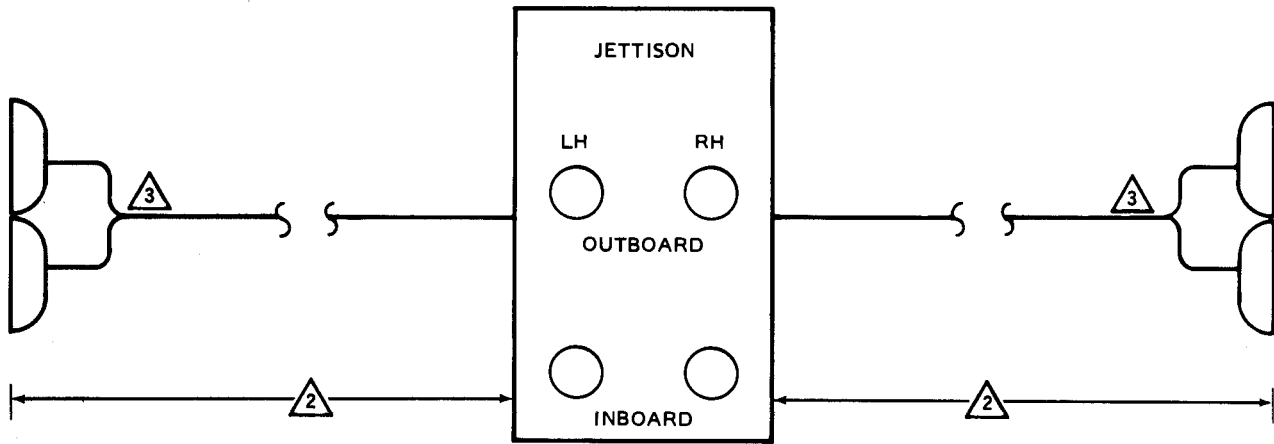

(a.) Face of Test Panel

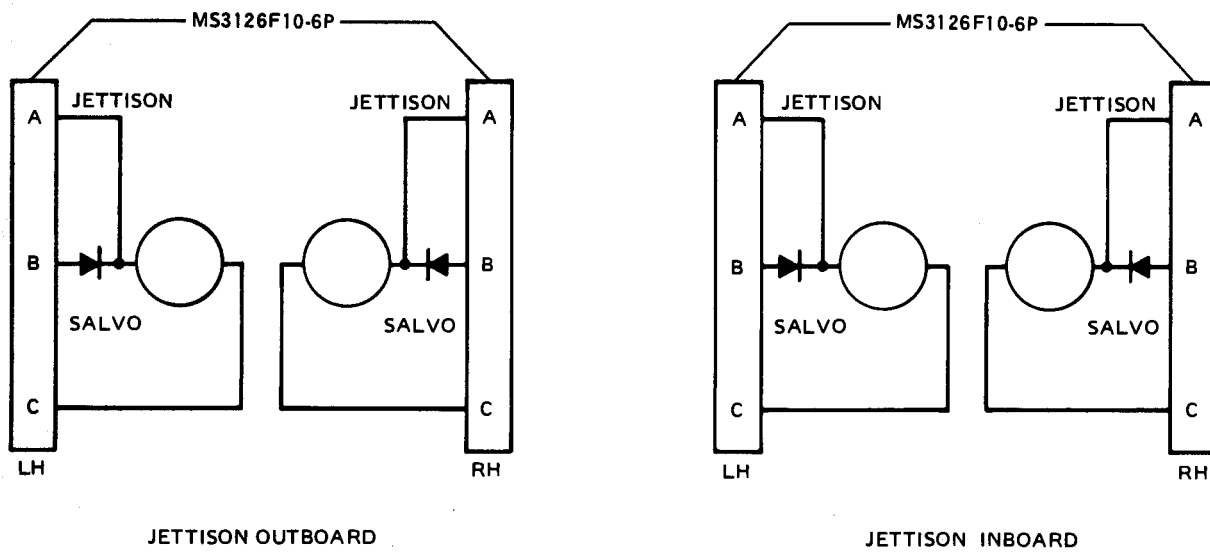

(b.) Schematic Diagram

- NOTES:** 1. All wires to be 20 gauge.  
 All lamps MS25237-327 or equivalent.
2. Cable length as required.

3. Connectors to mate receptacles 21SQ1J1, 21SQ2J1, 21SQ3J1, and 21SQ4J1, respectively.

**SCALE:** None

209475-509

Figure 9-28. **E** Wing Stores Circuitry Test Panel

b. Connect wing stores jettison test set cables to respective helicopter receptacles (21SQ1J1, 21SQ2J1, 21SQ3J1, and 21SQ4J1).

c. Connect a 28 Vdc external power source to helicopter external power receptacle and energize power source.

d. Ensure that JETTISON SELECT switches on pilot miscellaneous panel are in OFF position.

e. Ensure that WING STORE JETTISON switch on gunner instrument panel is in the down position and that metal guard is in place over the switch toggle.

f. Place WING STORES switch breakers on AC/ARMT circuit breaker panel to PLT JETT and GNR JETT. Check that no JETTISON lights on test set are illuminated and perform the checkout procedures, in wing stores jettison checkout chart, table 9-39.

Table 9-39. **E** Wing Stores Jettison Checkout Chart

Step	Pilot OUTBD JETTISON SELECT Switch (21S5)	Pilot INBD JETTISON SELECT Switch (21S4)	Gunner JETTISON SELECT Switch (21S2)	Pilot CLTV JETTISON Switch (21S3)	Gunner CLTV JETTISON Switch (21S1)	Results Test Set Jettison Lights
1	Close PLT JTSN circuit breaker.					No test set jettison lights
2	OFF	OFF	BOTH	Depress & Release	OFF	No test set jettison lights
3	OFF	OFF	INBD	Depress & Release	OFF	No test set jettison lights
4	OFF	OFF	OUTBD	Depress & Release	OFF	No test set jettison lights
5	OUTBD	OFF	BOTH	Depress & Release	OFF	Outboard lights illuminate&extinguish approximately 0.5 seconds later
6	OFF	INBD	BOTH	Depress & Release	OFF	Inboard lights illuminate and extinguish approx. 0.5 seconds later
7	OUTBD	INBD	BOTH	Depress & Release	OFF	Outboard and inboard lights illuminate and extinguish approx. 0.5 seconds later
8	OUTBD	INBD	BOTH	Released	JTSN	No test set jettison lights
9	OUTBD	OFF	BOTH	Released	JTSN	No test set jettison lights

Table 9-39. **E** Wing Stores Jettison Checkout Chart (Cont)

Step	Pilot OUTBD JETTISON SELECT Switch (21S5)	Pilot INBD JETTISON SELECT Switch (21S4)	Gunner JETTISON SELECT Switch (21S2)	Pilot JETTISON Switch (21S3)	Gunner JETTISON Switch (21S1)	Results Test Set Jettison Lights
10	OFF	INBD	both	Released	JTSN	No test set jettison lights
11	OFF	OFF	BOTH	Released	OFF	No test set jettison lights
12	Close GNR JTSN circuit breaker.					No test set jettison lights
13	OFF	OFF	INBD	Released	JTSN	Inboard lights illuminate
14	OFF	OFF	OUTBD	Released	JTSN	Outboard lights illuminate
15	OFF	OFF	BOTH	Released	JTSN	Outboard & inboard lights illuminate
16	Insert jumper wires between pins A & C for both connectors 20P8J01 & 20S8J01					
17	OFF	INBD	BOTH	Depress & Release	OFF	Outboard lights illuminate and extinguish approx. 0.5 seconds later
18	OFF	OFF	INBD	Released	JTSN	Outboard lights illuminate and remain illuminated
19	Repeat Set 13					
20	Open GNR JETT circuit breaker					
21	Repeat Steps 1, 2, 3, 4, 7, 8, 9, & 10					
22	Repeat Step 5					No test set jettison lights
23	Repeat Step 6					Only outboard lights illuminate and extinguish approximately 0.5 seconds later
24	Remove jumper wires from connectors 20P8J01 & 20S8J01					
25	Remove test set. Restore Wing stores wiring to normal configuration					

**9-495. E TROUBLESHOOTING - WING STORES JETTISON CIRCUITRY.**

of circuit malfunction or failure and has not been included.

Refer to paragraph F-9 in Appendix F for wiring diagram. Use Table 9-40 and perform checks as necessary to isolate trouble. In the following table, tripped circuit breakers are omitted from indications of trouble. Such trouble is usually easily detected and corrected. Broken wiring is always a probable cause

**NOTE**

Before you use this table, be sure you have performed all normal operational checks. If you have a malfunction which is not listed in this table, notify the next higher level of maintenance.

**Table 9-40. E Troubleshooting Wing Stores Jettison Circuitry**

**CONDITION****TEST OR INSPECTION****CORRECTIVE ACTION**

1. WING STORES JTSN and PLT JTSN circuit breakers are closed. Pilot JETTISON SELECT switches are positioned as required to jettison appropriate wing stores. Gunner JTSN SEL switch is in BOTH position and gunner JETTISON switch is in OFF position. The appropriate (outboard, inboard, or both) wing stores do not jettison when pilot collective JETTISON switch is depressed.

STEP 1. Check for defective wiring.

**Replace or repair wiring.**

STEP 2. Check for defective PLT JTSN or WING STORES JTSN circuit breakers. (21CB1 and/or 21CB2).

**Replace defective circuit breaker(s) (paragraph 9-23).**

STEP 3. Check for defective pilot collective JETTISON switch (21S3).

**Replace defective switch (paragraph 9-16).**

STEP 4. Check for defective pilot JETTISON SELECT switches (21S4 and/or 21S5).

**Replace defective switch(es) (paragraph 9-16).**

STEP 5. Check for defective or incorrectly installed diodes (21CR3, 21CR4).

**Replace defective diodes (paragraph 9-16).**

STEP 6. Check for defective pilot jettison switch relay (21K3).

**Replace defective relay (paragraph 9-16).**

STEP 7. Check for defective jettison control relay (21K2) or pilot jettison control relay (21K4).

**Replace defective relay (paragraph 9-16).**

Table 9-40. **E** Troubleshooting Wing Stores Jettison Circuitry (Cont)

---

**CONDITION**

**TEST OR INSPECTION**

**CORRECTIVE ACTION**

2. With conditions same as condition 1, appropriate wing stores are jettisoned on one side, but not on the other side when pilot collective JETTISON switch is depressed.

STEP 1. Check for defective wiring.

**Repair wiring, if defective (paragraph 9-16).**

STEP 2. Check for defective wing disconnect connectors (21J1/21P1, 21J3/21P3 or 21J2/21P2, 21J4/21P4) on side that does not jettison properly.

**Replace defective connector (paragraph 9-16).**

3. WING STORES JTSN, PLT JTSN, and GNR JTSN circuit breakers are closed. Pilot JETTISON SELECT switches are both positioned to OFF. Gunner JTSN SEL switch is positioned as required to jettison appropriate wing stores. Pilot collective JETTISON switch is released. The appropriate (outboard, inboard, or both) wing stores do not jettison when gunner JETTISON switch is positioned to JTSN.

STEP 1. Check for defective wiring.

**Replace or repair wiring.**

STEP 2. Check for defective GNR JTSN circuit breaker (21CB5).

**Replace circuit breaker (paragraph 9-23).**

STEP 3. Check for defective gunner JETTISON switch (21S1).

**Replace defective switch (paragraph 9-16).**

STEP 4. Check for defective gunner JTSN SEL switch (21S2).

**Replace defective switch (paragraph 9-16).**

STEP 5. Check for defective or incorrectly installed diodes (21CR5, 21CR6).

**Replace defective diodes (paragraph 9-16).**

STEP 6. Check for defective gunner jettison control relay (21K5).

**Replace defective relay (paragraph 9-16).**

STEP 7. Check for defective jettison control relay (21K2).

**Replace defective relay (paragraph 9-16).**

4. With conditions same as condition 3, appropriate wing stores are properly jettisoned on one side but not on the other side when gunner JETTISON switch is positioned to JTSN.

Table 9-40. **E** Troubleshooting Wing Stores Jettison Circuitry (Cont)

**CONDITION**

TEST OR INSPECTION

CORRECTIVE ACTION

STEP 1. Check for defective wiring.

Repair wiring, if defective.

STEP 2. Check for defective wing disconnect connectors (21J1/21P1, 21J3/21P3 or 21J2/21P2, 21J4/21P4) on side that does not jettison properly.

Replace defective connector (paragraph 9-16).

**SECTION X. **M** ARMAMENT AND FIRE CONTROL SYSTEMS CIRCUITRY**

**9-496. **M** ARMAMENT AND FIRE CONTROL SYSTEMS CIRCUITRY.**

**9-497. **M** DESCRIPTION - ARMAMENT AND FIRE CONTROL SYSTEMS CIRCUITRY.**

The armament systems consist of the universal turret subsystem, wing stores armament subsystem, XM-138 rocket management subsystem, M-136 helmet sight subsystem, and M65 TOW missile subsystem. The fire control system (FCS) consists of the XM22 fire control computer (FCC), XM76 head up display subsystem (HUD), XM143 Fire and flight air data subsystem (ADS), and airborne laser tracker (ALT). Functional test and troubleshooting procedures are presented for each armament subsystem circuitry. References are made to appropriate maintenance manuals and/or chapters within this maintenance manual, where applicable. Refer to paragraph F-9 in Appendix F for equipment location charts and wiring diagrams.

**9-498. **M** UNIVERSAL TURRET SUBSYSTEM CIRCUITRY.**

**9-499. **M** DESCRIPTION - UNIVERSAL TURRET SUBSYSTEM CIRCUITRY.**

The universal turret subsystem interfaces, by means of auxiliary equipment, with the M136 helmet sight

subsystem (HSS) and the turret control portion of the stabilized telescopic sight unit (TSU) of the M65 TOW missile subsystem. The interconnecting airframe wiring integrates the three subsystem components through the interface control unit (IFCU), electronic interface assembly, and the pilot and gunner armament control panels. For additional information pertaining to the universal turret subsystem, refer to TM 9-1090-206 series maintenance manuals. For additional information pertaining to the MI 36 helmet sight subsystem, refer to TM 9-1270-212-14. For additional information pertaining to the TSU and M65 TOW missile subsystem, refer to paragraph 9-518 and TM 9-1425-473 series maintenance manuals.

**9-500. **M** FUNCTIONAL TEST - UNIVERSAL TURRET SUBSYSTEM CIRCUITRY.**

**a. Requirements.**

**(1) Test equipment.**

**(a) Auxiliary power.** Ground power unit (T14).

**(b) Hydraulic.** Hydraulic ground test cart (T11).

**WARNING**

All weapons shall be dry fired. Only dummy ammunition with smooth cases like live ammunition shall be used.

**(2) Special tools.**

- (a) Round fire simulator (T5).
- (b) Airspeed simulator (T10).
- (c) Ground safety pins (2 required) (T66.1).

**b. Preparation for Testing.**

**(1) General.** Qualified armament personnel shall be present during all tests specified herein. The following tests shall be accomplished using auxiliary electrical power. (Refer to paragraph 1-54.)

**(2) Weapon system preparation.**

- (a) Check all system components for proper installation.
- (b) Install ground safety pin in each ejector rack.
- (c) Check that the turret weapon and feeder are properly timed.
- (d) Open (off) all circuit breakers.

**(3) Control switch positions.** Position the following switches as indicated:

**(a) Pilot armament control panel.**

MASTER ARM	OFF
WPN CONTR	GUNNER
WING STORE	RKT
HSS RCTL brightness knob	midpoint
RECOIL COMPEN	OFF
RANGE	SHORT

**(b) Pilot miscellaneous control panel,**

INBD JETTISON SELECT	OFF
OUTED JETTISON SELECT	OFF

**(c) Gunner armament control panel.**

PLT ORIDE	OFF
WING STORE	RKT
RD RMNG	750
TSU/GUN SLEW RATE	LOW
TUR SLEW	GND TEST

HSS reticle brightness knob	midpoint
LASER SAFE/	
TURRET DEPR LIMIT	DEPR LIMIT
RANGE	SHORT

**(d) TOW control panel.**

MODE SELECT	OFF
LASER ARM	OFF

**(e) Pilot instrument panel.**

RECOIL COMP	MED
-------------	-----

**(4) Electrical Power.** Apply 28-volt dc external electrical power. (Refer to paragraph 1 -51.)

**(5) Circuit breakers.** Engage the following circuit breakers:

**(a) DC circuit breaker panel.**

- GEN-FIELD
- DC VM
- CAUT LT
- GEN BUS RESET
- INV
- DPLR NAV

**(b) AC/AR MT circuit breaker panel,**

- ADS POWER
- TMS PWR
- ARMT CONTR
- WPN CONTR
- WPN FIRE
- HSS PWR
- REF XFMR
- SECU PWR
- WING STORE PWR
- TURRET DRIVE MOTOR
- TURRET GUN MOTOR
- TURRET STOW
- TMS BLWR
- PLT JETT
- GNR JETT
- FCC

**(6) Power switch positions.** Position the following switches as shown:

ALTNR	OFF/RESET
BATTERY	RUN
NON-ESNTL BUS	MANUAL



**(7) Gunners miscellaneous panel.** Position ELEC PWR/EMER OFF switch to ELEC PWR.



Before proceeding, clear turret area of any obstructions and warn personnel to remain on exterior of safety barrier.

### c. Testing Procedures.

**(1) Gunner turret control.** With test personnel in the pilot and gunner positions, connect the helmet sight linkage to the built-in test (BIT) brackets at the forward support points.

**(a)** With MASTER ARM switch on pilot armament control panel and PLT OR IDE switch on gunner armament control panel to OFF, check that there is no action or firing of any armament systems from any triggers. Check that green GUN ELEV STOWED caution light is illuminated in the pilot caution panel.

**(b)** Position pilot MASTER ARM switch to STBY. Observe that pilot and gunner STBY indicators are illuminated. Also observe that green GUN ELEV STOWED advisory light in the pilot caution panel is illuminated.

**(c)** Position HSS BIT switch on gunner armament control panel to BIT and check that a GO indication appears on the panel indicator.

#### NOTE

Completion of BIT circuit requires approximately two seconds.

**(d)** Check pilot and gunner HSS linkage for freedom of movement in all directions.

**(e)** Check that HSS reticle illumination controls on pilot and gunner armament control panels are functioning properly. Turn HSS RETICLE brightness control knob from OFF to BRT and check for corresponding change in light intensity. Move RETICLE TEST switch to TEST and check that HSS reticles are still illuminated.

**(f)** While holding gunner helmet sight line-of-sight (LOS) at 0 degrees elevation and 0 degrees azimuth; press left hand grip (LHG) ACTION switch on

TSU and slowly rotate LOS downward. The weapon should reach lower depression limit at approximately -5 degrees. Then rotate LOS upward; the weapon should drive to the upper limit. The reticle should flash when helmet LOS is out of coincidence with the commanded gun line and when weapon reaches upper elevation limit or below zero degrees elevation. Release ACTION switch.

**(g)** Position LASER SAFE/TURRET DEPR LIMIT switch to OFF.



In the following steps, excessive downward movement of LOS can cause barrels to strike ground. Remove barrels or elevate helicopter 30 inches if maximum depression cannot be checked during flight test.

**(h)** While holding gunner helmet sight LOS at 0 degrees elevation and 0 degrees azimuth, press LHG ACTION switch on TSU and slowly rotate helmet LOS downward. Confirm that gun barrels move past the 5 degree depression limit position. Rotate LOS upward and confirm that gun barrels move to upper elevation limit. Release ACTION switch.

**(i)** Move turret through total elevation, depression, and azimuth limits. Check that no binding or interference occurs.

**(j)** Rotate sight rapidly both in azimuth and elevation. Check that sight reticle flashes momentarily as turret and HSS LOS are out of coincidence.

**(k)** Move turret against upper elevation limit and slowly through total azimuth sweep. Check that reticle flashes while turret is against upper limit in all azimuth positions.

**(l)** Move turret against left and right azimuth limits and slowly through total elevation sweep. Check that reticle flashes while turret is against either azimuth limit in all elevation positions. Total depression at either azimuth shall be checked during flight tests.

**(m)** Release ACTION switch on the LHG and check that the turret returns to stowed (upper forward) position.

(n) Return LASER SAFE/TURRET DEPR LIMIT switch to ON.

(o) Hold the sight in approximately the 0-0 position and depress ACTION switch on LHG. Attempt to fire the weapon with the gunner and pilot cyclic triggers. The weapon should not fire.

(p) Position pilot MASTER ARM switch to ARM, Check that pilot and gunner red ARMED indicators are illuminated and that pilot and gunner STBY indicators are extinguished.

(q) Press ACTION switch while holding helmet LOS at 0 degree azimuth and 0 degree elevation and move RANGE switch to MED and LONG. Check that turret elevation increases with increased range settings. Check that helmet sight reticle does not flash at SHORT, MED OR LONG range settings. Release ACTION switch. Return RANGE switch to SHORT.

(r) Press ACTION switch and move LHG trigger on gunner TSU to the first detent, then the second. Check that turret weapon fires a  $16 \pm 4$  round burst at first detent and continuously at second detent.

(s) Release ACTION switch and press the trigger. The turret weapon should not fire. Press pilot ACTION switch and trigger. Check that weapon does not move or fire. Press gunner cyclic ACTION switch and trigger. Check that turret weapon does not move or fire.

**(2) Pilot turret control.** Proceed as follows to check out and test turret weapon and HSS system while under pilot control:

(a) Position MASTER ARM switch to STBY.

(b) Position pilot WPN CONTR switch to PILOT. Check that PILOT IN CONT indicator on gunner armament control panel illuminates.

(c) Press TSU LHG ACTION switch. Check that gunner helmet sight has no control of the turret.

(d) Press gunner cyclic grip ACTION switch. Check that gunner helmet sight has no control of the turret weapon.

(e) Press ACTION switch on pilot cyclic grip and check that turret weapon follows pilot helmet

sight LOS in the same manner as that described for the gunner in subparagraph (1), steps (f) through (n) above.

(f) Position MASTER ARM switch to ARM.

(g) Repeat steps (q) and (r) of subparagraph (1) above, except use pilot cyclic stick ACTION switch.

(h) Check that pilot cyclic stick trigger fires turret weapon: a  $16 \pm 4$  round burst at first detent and continuously at second detent.

**(3) Pilot override by gunner.** Proceed as follows to check out function of gunner overriding pilot control of weapon:

(a) Position pilot override switch to PLT ORIDE.

(b) Check that PLT IN CONT indicator extinguishes and that pilot and gunner red ARMED indicator illuminates.

(c) Press gunner cyclic stick ACTION switch and check that gunner cyclic stick trigger will fire the turret weapon. The gunner HSS should control turret weapon.

(d) Press LHG ACTION switch and trigger. Check that turret weapon does not respond to helmet sight and gun does not fire.

(e) Press pilot cyclic stick action switch and trigger. Check that pilot helmet sight will not control the turret weapon and that gun does not fire.

(f) Position pilot MASTER ARM switch to OFF and check that both pilot and gunner red ARMED indicator lights remain on. Check that only gunner cyclic stick trigger will fire turret weapon.

(g) Position pilot WPN CONTR switch to GUNNER. Check that only gunner cyclic stick trigger will fire turret weapon.

(h) If ammunition box booster is connected during the preceding checks, counter should show less than 250 rounds (corresponding to the number of rounds fired).

(i) Return PLT ORIDE switch to OFF.

**(4) Turret airspeed compensation.** Check out the contribution of airspeed to the fire control solution as follows:

(a) Position MASTER ARM switch to STBY.

(b) Position MODE SELECT switch to TSU/GUN.

(c) Ascertain that the ADS ANTIICE circuit breaker is OFF and ADS pitot tube is cool enough to handle.

(d) Apply air pressure to the air data subsystem EPU to simulate  $100 \pm 5$  knots airspeed. Position pitot tube to straight ahead.

(e) Press LHG ACTION switch and using the SHC stick rotate the LOS of the TSU to 90 degrees left. Turret weapon will follow the sight to the left. Switch the FCC/OFF breaker to OFF. The gun shall move forward, closer to zero degrees azimuth. Reset the breaker to FCC. The gun shall move farther away from zero degrees azimuth.

(f) Repeat step (e) at 90 degrees right. In both cases forward airspeed causes the gun to deflect farther away from zero degrees azimuth.

(g) Repeat step (e) at a depressed elevation angle. Use caution that barrels do not hit ground. As before, forward airspeed causes the gun to deflect farther from the forward position.

(h) Turn MODE SELECT switch to OFF.

(i) Turn MASTER ARM to OFF.

**(5) Fixed mode firing.** Check out fixed mode firing as follows:

(a) Position pilot WPN CONTR switch to FIXED, MASTER ARM switch to STBY, HUD PWR switch to ON, HUD MODE switch to NORM, HUD AUTO BAT as desired, and adjust HUD brightness knob.

(b) Check that turret weapon moves to 0-degree elevation and 0-degree azimuth position.

(c) Press pilot cyclic grip ACTION switch. Check that turret weapon does not follow pilot helmet sight.

(d) Press ACTION switch on TSU LHG and cyclic grip ACTION switch. Check that turret weapon does not follow gunner helmet sight or TSU commands.

(e) Position MASTER ARM switch to ARM.

(f) Press pilot cyclic grip ACTION switch and trigger. Check that turret weapon fires. Check that rocket direct reticle is positioned to 0-0 on HUD.

**(6) Range compensation.** Check out range compensation operation as follows:

(a) Disengage FCC circuit breaker. Position MASTER ARM switch to STBY, MODE SELECT switch on TOW Control Panel (TCP) to TSU/GUN, HI/LO MAG switch to HI, WPN CONTR to GUNNER, and LRF/PWR circuit breaker to OFF.

(b) Position STOW/TRK/ACQ switch on SHC to TRK and hold TSU LOS on a fixed distant target.

(c) Press ACTION switch on LHG. Position RANGE switch to SHORT. Position MASTER ARM switch to ARM. Position FCC/OFF circuit breaker to FCC. Check that turret weapon elevation increases by approximately **9.2** milliradians above FCC OFF position.

(d) Position RANGE switch to MED. Check that turret weapon elevation increases by approximately **24.4** milliradians above FCC OFF position.

(e) Position RANGE switch to LONG. Check that turret weapon elevation increases by approximately **42.8** milliradians above FCC OFF position.

(f) Return RANGE switch to SHORT. Release ACTION switch. Position MASTER ARM switch to OFF.

**(7) Recoil compensation**



**Do not apply hydraulic power to system unless electrical power is applied.**

(a) Apply  $1500 \pm 25$  psig hydraulic power to both systems.

(b) Connect Round Fire Simulator to FIRE VOLT CONNECTOR.

(c) Engage SCAS circuit breakers. Position RECOIL COMP select switch to MED. Position RECOIL COMPEN switch to RECOIL COMPEN and power switch on SCAS control panel to PWR. Engage PITCH, ROLL and YAW ENGAGE switches.

(d) Position WPN CONTR switch to GUNNER. Position MASTER ARM switch to ARM. Press LHG ACTION switch, Rotate sight 90 degrees left. Observe turret is 90 degrees left and level. Press LHG trigger. Observe SCAS inputs to tail rotor and swashplate. Tail rotor response shall be the same as for left pedal inputs. Swashplate inputs shall be the same as for right cyclic stick (right roll swashplate).

(e) Repeat for 90 degrees right and level. Tail rotor response shall be the same as for right pedal inputs. Swashplate inputs shall be the same as for left cyclic stick (left roll swashplate).

(f) Repeat for 0 degrees and up elevation. Swashplate inputs shall be the same as for aft stick.

(g) Repeat for 0 degrees and down elevation. Swashplate inputs shall be the same as for forward stick.

(h) Repeat steps (c) through (g) with RECOIL COMP switch in LOW. Observe smaller inputs to tail rotor and swashplate.

(i) Repeat steps (c) through (g) with RECOIL COMP switch in HIGH. Observe larger inputs to tail rotor and swashplate.

(j) Open all armament switches and disengage circuit breakers. disconnect hydraulic power cart and Round Fire Simulator.

### 9-501. **M** TROUBLESHOOTING - TURRET SUBSYSTEM CIRCUITRY.

a. For troubleshooting procedures, refer to TM 55-1520-236-T.

b. **Turret Subsystem.** Refer to TM 9-1090-206 series maintenance manuals for troubleshooting procedures pertaining to the universal turret subsystem.

c. **Helmet Sight Subsystem.** Refer to TM 9-1270-212-14 for troubleshooting procedures pertaining to the M136 helmet sight subsystem.

d. **Telescopic Sight Unit.** Refer to TM 9-1425-473 series maintenance manuals for troubleshooting

procedures pertaining to the telescopic sight unit portion of the M65 TOW missile subsystem.

### 9-502. **M** M136 ELECTRONIC INTERFACE ASSEMBLY.

### 9-503. **M** DESCRIPTION - M136 ELECTRONIC INTERFACE ASSEMBLY.

The electronic interface assembly is a component of the M 136 helmet sight subsystem that provides regulated 28 Vdc power and contains the electronic components necessary for the operation of the HSS. The electronic interface assembly is the point of integration with the interface control unit (IFCU) which interfaces the HSS and TSU sighting systems with the universal turret system. The electronic interface assembly is mounted to the rear cockpit bulkhead (refer to paragraph F-9 in Appendix F for equipment location charts).

The electronic interface assembly contains buffer amplifiers and circuitry required by the linkage resolvers, azimuth and elevation alignment controls and associated circuitry for boresighting each linkage assembly, and the BITE circuits and controls necessary to provide the HSS self-test capability. For additional information and maintenance procedures pertaining to the electronic interface assembly, refer to TM 9-1270-212-14.

### 9-504. **M** INTERFACE CONTROL UNIT (IFCU).

### 9-505. **M** DESCRIPTION - INTERFACE CONTROL UNIT (IFCU).

The interface control unit (IFCU) contains the signal switching, signal buffering, reticle lamp and retract circuitry, and offset signals from and logic outputs to the fire control computer (FCC) necessary to interface the helmet sight subsystem (HSS), stabilized telescopic sight unit (TSU), airborne laser tracker (ALT), and the FCC with the turret subsystem. The IFCU is located in the right access compartment below the wing. See equipment location charts and wiring diagrams in Appendix F. (Refer to paragraph F-9 for appropriate chart and wiring diagram locations). When the gunner selects the gun mode of the TOW system, the computing resolver chain contained within the turret subsystem is connected to similar resolvers located in the TSU. Elevation and azimuth commands function are then developed in the TSU which are returned to the turret subsystem as

positioning signals for the turret assembly. The FCC is parallel to the computing resolver chain loop and adds offset inputs through the IFCU buffer amplifiers for range and air data compensation and boresight corrections using the TSU as a baseline. If the FCC is not operable, the IFCU eliminates it from the loop and processes basic line-of-sight information without compensation or boresight correction. In this manner, as the TSU tracks the target, the turret assembly is commanded to follow the TSU line-of-sight. Operation with either the pilot or gunner helmet sight is accomplished in a like manner. The function of the IFCU is to receive signals from all three sighting units and to select the appropriate one, depending upon the mode activated by the subsystem operator. This interchange of signals is accomplished in the IFCU with the use of relay logic. Once the sighting unit is selected, turret positioning signals are routed from the sight back through the IFCU integrated circuit buffer amplifiers to the selected sight/resolver. The amplifiers are incorporated to ensure that computing accuracy in the resolver chain is maintained. In addition to the gun modes, an acquisition mode is provided in which either helmet sight or the ALT positions the TSU. The acquisition mode thus allows either the pilot, the gunner, or the ALT, to acquire a target for the TOW missile or turret gun by utilizing the helmet sight or ALT. The relay logic in the IFCU also provides a dual mode capability. If the gunner has selected the TOW mode, the pilot has the capability of directing the turret assembly while the other helmet sight is used to acquire a target for the TOW missile or the turret gun. Relays to eliminate signals from the FCC when it is in a failed condition are in the IFCU. The IFCU provides logic signals to the FCC to establish the mode that has been selected.

**9-506. M CLEANING - INTERFACE CONTROL UNIT (IFCU).**

a. Remove moisture and loose dirt with a clean, soft cloth.



**Cleaning solvent is flammable and toxic. Provide adequate ventilation. Avoid prolonged breathing of solvent vapors and contact with skin or eyes.**

b. Remove grease, fungus, and dirt with a clean, lint-free cloth dampened with dry cleaning solvent (C112).

c. Remove dirt from electrical connectors with a bristle brush.

**9-507. M INSPECTION - INTERFACE CONTROL UNIT (IFCU).**

a. Inspect IFCU case for cracks or damage.

b. Inspect electrical connectors for broken pins or cracked connector inserts.

c. Inspect IFCU for secure mounting.

**9-508. M REMOVAL - INTERFACE CONTROL UNIT (IFCU).**

a. Ensure all electrical power is OFF.

b. Remove IFCU access panel (right side, below wing).

c. Disconnect three electrical connectors from IFCU. Protect receptacles and plugs with caps or electrical tape (C121).

d. Remove mounting screws and washers, and remove IFCU from shelf.

**9-509. M REPAIR - INTERFACE CONTROL UNIT (IFCU).**

a. Repair connectors, and tighten or replace loose or missing mounting screws.

b. Replace IFCU if case is damaged or defective. Evacuate removed IFCU to higher maintenance level for disposition.

**9-510. M INSTALLATION - INTERFACE CONTROL UNIT (IFCU).**

a. Position IFCU in place on shelf and install mounting screws and washers.

b. Remove protective caps or electrical tape from three electrical connectors and install on IFCU.

**9-511. M LOGIC CONTROL UNIT.**

**9-512. M DESCRIPTION - LOGIC CONTROL UNIT.**

The logic control unit (LCU) is an interface unit and a component of the universal turret system. It interfaces with the turret control unit, gun control

unit, SCAS armament compensation unit, and the interface control unit. The LCU is located aft of the ammunition compartment. Access to the unit is gained through the access panel located on the left side of the helicopter above the forward crosstube. SCAS compensation signals are provided by a program switch on the LCU. The program switch selects various circuit configurations in the LCU to provide for the difference in movement associated with the individual weapon that is installed (20MM or 30 MM). Logic command circuits in the LCU provide a torque enable signal to indicate use of the pitch, roll, and yaw signals by the SCAS system. Two 1.5 degree error detection circuits, one for azimuth and one for elevation, are provided to prevent the weapon from firing if the turret returns to normal stow while still clearing. Also, a 180 degree interlock circuit is provided to prevent or interrupt weapon firing when the turret and sight are not in normal azimuth alignment. Depression limiting circuitry is provided to prevent the turret from depressing further than a 5 degree down angle. When the turret elevation angle is changed, a resolver generates a voltage which is proportional to the sine function of that angular displacement. This signal is demodulated into a proportional linear dc voltage. The demodulation circuitry is identical to that used in the turret control assembly. The second functional section of the circuit detects the phase (direction) and amplitude (angle) of the demodulators output. When the turret direction is down and equal to or greater than 5 degrees, a transistor is energized providing a ground return for a relay coil which is powered by the helicopter electrical circuitry. This accomplishes elevation error cancellation and prevents the turret from depressing further than the 5 degree down angle. A burst length limiting circuit with burst limit override logic interfaces with the gun control unit. The program switch on the LCU selects the proper time delay for the weapon installed. The burst limit override disables the time delay function by disconnecting the trigger signal from the timing circuit. A four input OR circuit is provided to interface the 180 degree, 1.5 degree azimuth, and turret electrical interlocks to the gun control unit. A 180 degree false coincidence circuit is provided to prevent turret latch-up when the selected sight position differs from the weapon boreline by more than 180 degrees due to rapid rotation of the helmet sight or mode switching. Other LCU circuits include a transistor inverter for the reticle and an elapsed time indicator.

#### 9-513. **M** CLEANING - LOGIC CONTROL UNIT (LCU).

- a. Remove moisture and loose dirt with a clean, soft cloth.

#### **WARNING**

Cleaning solvent is flammable and toxic. Provide adequate ventilation. Avoid prolonged breathing of solvent vapors and contact with skin or eyes.

- b. Remove grease, fungus, and dirt with a clean, lint-free cloth dampened with dry cleaning solvent (C112).
- c. Remove dirt from electrical connectors with a bristle brush.

#### 9-514. **M** INSPECTION - LOGIC CONTROL UNIT (LCU).

- a. Inspect LCU case for cracks or damage.
- b. Inspect electrical connectors for broken pins or cracked connector inserts.
- c. Inspect LCU for secure mounting.

#### 9-515. **M** REMOVAL - LOGIC CONTROL UNIT (LCU).

- a. Ensure all electrical power is off.
- b. Remove access panel aft of ammunition compartment above forward crosstube on left side of helicopter.
- c. Disconnect electrical connectors from LCU. Protect receptacles and plugs with caps or electrical tape (C121).
- d. Remove mounting screws and washers. Remove LCU from helicopter.

#### 9-516. **M** REPAIR - LOGIC CONTROL UNIT (LCU).

- a. Repair connectors and tighten or replace loose or missing mounting screws.
- b. Replace LCU if case is damaged or defective. Evacuate removed LCU to higher maintenance level for disposition.

**9-517. M INSTALLATION - LOGIC CONTROL UNIT (LCU).**

- a. Position LCU in place and install with mounting screws and washers.
- b. Remove protective caps or electrical tape and connect electrical connectors to LCU.

**9-518. M TU TURRET BUFFER AMPLIFIER.****9-519. M DESCRIPTION - TURRET BUFFER AMPLIFIER.**

The turret buffer amplifier contains the buffering circuitry to eliminate noise and to provide loads for the turret resolvers which are compatible with the resolver design requirements. This unit also contains relay interlock switching which will cause interruption of the firing voltage if an internal power supply failure occurs. The line-of-sight signals buffered by the buffer amplifier isolate the resolvers from incompatible capacitance loading effects within the logic control unit and the turret control unit in order that required signal accuracy can be maintained. Signal noise from the turret control unit which would otherwise result in erratic FCC and/or turret response, is eliminated by the turret buffer amplifier. Buffers between the turret and the IFCU provide low impedance line drivers and isolate turret resolvers from external loads. The configuration of the grounds within the turret buffer amplifier provide a means to eliminate possible ground loops which can be detrimental to resolver signal accuracy. The turret buffer amplifier also processes the helicopter supplied 10 volt reference to be applied to the turret such that the resulting resolver reference voltages are compatible with the remainder of the weapon system components. The turret buffer amplifier provides its own separate symmetrical power supply for the buffer amplifiers and interlock relays within the unit. The unit is located in series with the ships wiring between the turret and the remainder of the ships wiring. Signal lines not requiring buffering are straight through connections within the turret buffer amplifier. The unit is located on the bulkhead just aft of the turret.

**9-520. M CLEANING - TURRET BUFFER AMPLIFIER.**

- a. Remove moisture and loose dirt with a clean, soft cloth.

**WARNING**

**Cleaning solvent is flammable and toxic, Provide adequate ventilation. Avoid prolonged breathing of solvent vapors and contact with skin or eyes.**

- b. Remove grease, fungus, and ground-in dirt with a clean, lint-free cloth dampened with dry cleaning solvent (C112).
- c. Remove dirt from electrical connectors with a bristle brush.

**9-521. M REMOVAL - TURRET BUFFER AMPLIFIER.**

- a. Ensure all electrical power is OFF.
- b. Remove left side turret fairing.
- c. Disconnect electrical connectors from turret buffer amplifier and protect with caps or electrical tape (C121).
- d. Remove mounting screws and washers and remove amplifier.

**9-522. M REPAIR - TURRET BUFFER AMPLIFIER.**

- a. Repair connectors, and tighten or replace loose or missing mounting screws.
- b. Replace turret buffer amplifier if case is damaged or defective. Evacuate turret buffer amplifier to higher maintenance level for disposition.

**9-523. M INSTALLATION - TURRET BUFFER AMPLIFIER.**

- a. Position turret buffer amplifier on bulkhead just aft of turret and install mounting screws and washers.
- b. Remove protective caps or tape and install electrical connectors.

**9-524. M MCN M65 OR M65/C-NITE TOW MISSILE SUBSYSTEM CIRCUITRY.**

**WARNING**

The laser beam is dangerous and can cause blindness if it enters the eye either directly or reflected from a shiny surface. Therefore, during ground operation, laser light leakage due to improper mounting of the TSU window cover may cause injury to the eye. Ensure that the window cover is mated to the TSU window prior to firing the LAAT laser with the LASER switch on the LHG.

**9-525. M MCN DESCRIPTION - M65 OR M65/C-NITE TOW MISSILE SUBSYSTEM CIRCUITRY.**

The M65 TOW missile subsystem circuitry provides the capabilities to acquire and track a target, compensate for effects of helicopter motion, launch a TOW missile, and guide the missile to the target. The telescopic sight unit (TSU) portion of the TOW missile subsystem interfaces with the universal turret system circuitry, serving as a flexible sighting unit, and also interfaces with the helmet sight subsystem for use during target acquisition. A laser range finder (LRF) is utilized to determine distance to target. The laser rangefinder interfaces with the fire control computer (FCC). Range data is displayed in the telescopic sight unit (TSU) and head-up display (HUD). The M65/C-NITE TSU contains a forward looking infrared (FLIR) sensor which provides the capability to track the IR beacon of the TOW 2 missile. The FLIR sensor allows the system to detect and track targets during periods of darkness, under obscured battlefield conditions, or in the presence of missile countermeasures. The M65/C-NITE components are FLIR control panel (FCP), FLIR power supply (FPS), and FLIR missile tracker (FMT). For description and additional information pertaining to M65 TOW missile subsystem components, refer to TM 55-1520-236-10 and TM 9-1425-473 series maintenance manuals. For maintenance information and procedures pertaining to M65 TOW missile subsystem components, refer to TM 9-1425-473 series maintenance manuals. For information and maintenance procedures pertaining to the interface control unit (IFCU), refer to paragraph 9-504.

**9-526. M MCN FUNCTIONAL TEST - M65 OR M65/C-NITE TOW MISSILE SUBSYSTEM CIRCUITRY.**

**a. Requirements.**

**(1) Test equipment.**

**(a) Auxiliary power.** Auxiliary power unit (T14).

**(b) Hydraulic.** Hydraulic ground test cart (T11).

**(2) Special tools.**

**(a) TOW simulator evaluation missile TSEM)** (T70).

**(b) IR target simulator** (T88).

**(c) Corrector lens** (T87).

**b. Preparation for Testing.**

**(1) General.** Qualified armament personnel shall be present during all tests specified herein.

**(2) Configuration.** For the purpose of this test, the universal turret will be assumed to have a 20MM weapon.

**NOTE**

**For functional test of M65 TOW missile launcher system refer to TM 9-1425-473 series maintenance manuals.**

**(3) Weapon system preparation.**

**(a) Check all systems components for proper installation.**

**(b) Verify that the launchers are properly connected, four launchers installed, and the TSEM installed in No. 1 missile position. (See figure 9-29.)**

**(c) Open (off) all circuit breakers.**

**(d) Install ground safety pin in each outboard ejector rack.**



(e) Position IR target simulator (T88) and corrector lens (T87) in accordance with TM 9-1425-473-20.

(4) **Control switch positions.** Position the following switches as indicated:

(a) **Pilot armament control panel.**

MASTER ARM	OFF
WPN CONTR	GUNNER
WING STORE	RKT

(b) **Gunner armament control panel.**

WING STORE	RKT
LASER SAFE/	
TURRET DEPR LIMIT	DEPR LIMIT
PLT ORIDE	OFF
TSU\GUN SLEW RATE	HIGH



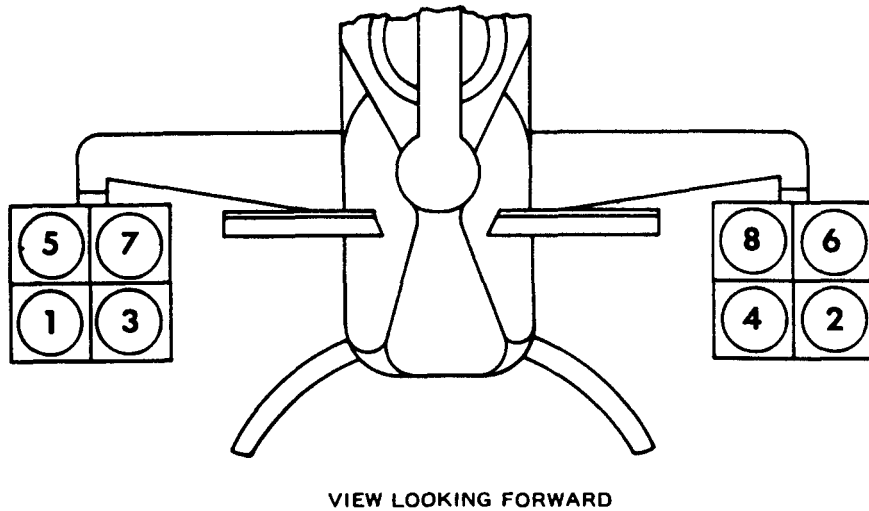

Figure 9-29. **M** TOW Missile Launcher Positions

TURRET SLEW  
RANGE  
RD RMNG

GND TEST  
SHORT  
750

**(5) Electrical power.** Check that the aircraft battery is connected, then apply 28-volt dc external electrical power.

**(6) Circuit breakers.** Engage the following circuit breakers:

**(c) TOW control panel (TCP).**

MODE SELECT	OFF
CAMERA	OFF
MISSILE SELECT	1
LASER ARM	OFF

**NOTE**

**Ensure circuit breakers in battery compartment are engaged.**

**(d) Head up display.**

PWR	STBY
MODE	NORM

GEN FIELD  
DC VM  
CAUT LT  
INV  
GEN BUS RESET

**(e) Sight hand control (SHC).**

STOW/TRK/ACQ	STOW
--------------	------

**(b) Ac circuit breaker panel.**

**(f) Telescopic sight unit (TSU).**

FILTER SELECT LEVER	CLEAR
---------------------	-------

HUD BLWR  
HUD PWR  
ARMT CONTR  
TMS PWR  
TMS BLWR  
WPN CONTR  
WPN FIRE  
HSS PWR  
REF XFMR

**(g) **MCN** FLIR control panel (FCP).**

OFF/ON/BIT	OFF
BORESIGHT	OFF

SECU PWR  
 WING STORE PWR  
 TURRET PWR  
 TURRET DRIVE MOTOR

(7) **Power switch positions.** Position the following switches as shown:

ALTNR	OFF RESET
BATTERY	RUN
NON-ESNTL BUS	MANUAL
ELECT PWR/EMER OFF	ELEC PWR

**WARNING**

Before proceeding, clear turret area of any obstructions and warn personnel to remain on exterior of safety barrier.

**CAUTION**

To ensure immediate control of the system, do not apply hydraulic power to system unless electrical power is applied.

(8) **Hydraulic power.** Apply 1500 ±25 psi hydraulic power to system No. 2.

(9) **Special test equipment.** Position the following test equipment switches or controls as indicated:

TOW system evaluator missile (TSEM).

POWER	OFF
FUNCTION	LAMP TEST

**c. Testing Procedures.**

(1) **Initial system tests.** Perform the following steps for initial system tests:

**NOTE**

For this test, one technician will be required in the gunner position, one technician in the pilot position, and one technician outside the helicopter.

(a) Position the pilot MASTER ARM switch to STBY, WPN CONTR switch to GUNNER, HUD PWR switch to ON, and adjust HUD BRT knob.

(a.1) **MCN** Position FCP OFF/ON/BIT switch to ON.

(b) Position the TCP MODE SELECT switch to TSU/GUN.

(c) Verify that system status indicator on TCP moves from OFF to TEST after approximately 10 seconds.

(d) Verify that within 120 seconds after TCP system status indicator reads TEST in step (c), the TCP system status indicator moves to PWR ON.

(d.1) Verify FCP mode indicator displays TEST.

(e) Verify that all BIT indicators on the TCP are black.

**NOTE**

( **MCN** ) DET HOT will remain displayed on FCP mode indicator until FLIR IR detectors have cooled to operating temperature. This indication may take as long as 15 minutes to clear screen.

(e.1) **MCN** Verify BIT indicators on FCP are black.

(f) Apply air pressure to the pitot system to simulate 100 ±5 knots airspeed.

(g) To assure proper operation of the airspeed pressure transducer verify that 5.0 ± 1.0 volts are present between terminals CI and E2 on terminal board 19TB6. This terminal board is located on the LH side of the A/Cat approximately STA. 148.50 and WL 50.

(h) Release air pressure from the pitot system.

(i) Move MAG switch on LHG to LO.

(i.1) **MCN** Move MAG switch on LHG to DAY.

(j) Move STOW/TRK/ACQ switch to TRK. Observe that TSU turret follows the inputs from SHC transducer stick and that status flag in TSU is visible. Verify that turret weapon does not follow the sight.

(k) Position LASER SAFE/TURRET DEPR LIMIT switch to OFF.



**Do not depress TSU or gun barrels during the following check if gun barrels are installed. Barrels could strike the ground with sufficient force to cause system damage.**

(l) Press ACTION switch on LHG. Observe that turret weapon follows TSU turret when moved through the limits with SHC transducer stick. Observe that GUNS flag in TSU sight flashes when at limit stops of the turret weapon.

**NOTE**

**Guns flag may not flash if gun turret exceeds TSU turret in azimuth, due to tolerance in stop location.**

(m) Release ACTION switch. Observe that turret weapon returns to STOW.

(n) Move LOS of TSU to approximately 0 degrees azimuth and elevation and press LHG ACTION switch and trigger. Observe that turret weapon will not fire.

(o) Release ACTION switch. Position pilot MASTER ARM switch to ARM.

(p) Move LOS on TSU to approximately 0 degrees azimuth and elevation and press LHG ACTION switch and trigger. Observe that turret weapon fires.

(q) Release ACTION switch and position MASTER ARM switch on pilot armament control panel to STBY.

(r) Return STOW/TRK/ACQ switch to STOW.

(s) Return LASER/SAFE TURRET DEPR LIMIT switch to DEPR LIMIT.

**(2) Telescopic sight controls.** Perform the following steps for initial system turn-on:

(a) **MCN** Position FCP OFF/ON/BIT switch to OFF.

(a.1) Position MODE SELECT switch to STBY TOW on TOW control panel (TCP). Verify that TCP system status indicator remains at PWR ON.

(a.2) **MCN** Verify FCP mode indicator indicates OFF.

(b) Position STOW/TRK/ACQ switch to TRK and press LHG ACTION switch. Observe that turret weapon will not follow inputs from SHC transducer stick.

(c) Release LHG ACTION switch and return STOW/TRK/ACQ switch to STOW.

(d) Position TCP MODE SELECT switch from STBY TOW to ARMED MAN. Verify that TCP system status indicator remains at PWR ON.

(d.1) **MCN** Observe that FCP mode indicator indicates OFF.

(e) Position MASTER ARM switch on pilot armament control panel from STBY to ARM to STBY. Verify that system status indicator on TCP moves from PWR ON to ARMD to PWR ON during this sequence.

(e.1) **MCN** Verify that FCP mode indicator changes from OFF to PWR ON or DET HOT to OFF during this sequence.

(f) position WPN CONTR switch on pilot armament control panel to PILOT.

(g) Position MASTER ARM switch from STBY to ARM to STBY. Verify that system status indicator on TCP remains at PWR ON during this sequence.

(g.1) **MCN** Verify FCP mode indicator indicates OFF during this sequence.

(h) Position WPN CONTR switch on pilot armament control panel to FIXED and repeat step (g). Return WPN CONTR switch to GUNNER.

(i) Position STOW/TRK/ACQ switch on SHC to TRK and return to STOW. Verify that system status indicator remains in the PWR ON position during this sequence.

**NOTE**

**Steps (j), (k), (l), and (m) should be done in rapid succession in order to maintain the TEST indication. Read these steps before their initiation.**

(j) Press and hold BIT pushbutton on TCP. Verify that A, R, and G flags are visible in TSU eyepiece. Verify that ascend and descend pointers and prelaunch window are displayed on head up display (HUD). Release BIT SWITCH after verifying the above and check that system status indicator on TCP reads TEST.

(k) Position TCP MODE SELECT switch from ARMED MAN to OFF to ARMED MAN in less than 5 seconds. Verify that system status indicator on TCP moves from TEST to OFF to TEST. There should be no 10-second delay from OFF to TEST on TCP system status indicator.

(l) With system status indicator reading TEST from step (k), position STOW/TRK/ACQ switch on sight hand control to TRK and return it to STOW. Verify that system status indicator cycles from TEST to PWR ON to TEST during this sequence.

(m) With system status indicator reading TEST from step (l), position MASTER ARM switch on pilot armament control panel from STBY to ARM to OFF. Verify that system status indicator on TCP moves from TEST to ARMD to OFF during this sequence.

(n) Position pilot MASTER ARM switch to ARM, the STOW/TRK/ACQ switch on SHC to TRK and position TCP MODE SELECT switch to STBY TOW.

(o) Position TSU optics to HI using MAG switch in TSU LHG grip. Observe that TSU is now in HI mode.

(p) Press and hold ACTION switch. Use SHC stick to drive TSU from stop to stop horizontally. Verify that TSU can be driven stop to stop in less than 63 seconds. Release ACTION switch.

(p.1) Press and hold ACTION switch. Use SHC stick to drive TSU from stop to stop vertically. Verify that TSU can be driven stop to stop in less than 27 seconds. Release ACTION switch.

(q) Position TSU optics to LO using MAG switch on TSU LHG grip.

(r) Press and hold ACTION switch. Use SHC stick to drive TSU from stop to stop horizontally. Verify that TSU can be driven stop to stop in less than 3 seconds. Release ACTION switch.

(r.1) Press and hold ACTION switch. Use SHC stick to drive TSU from stop to stop vertically. Verify that TSU can be driven stop to stop in less than 2 seconds. Release ACTION switch.

(s) Position TSU OPTICS to HI using MAG switch and position TCP MODE SELECT switch to TSU/GUN.

(t) Press and hold ACTION switch. Use SHC stick to drive TSU from stop to stop horizontally. Verify that TSU can be driven stop to stop horizontally in less than 8 seconds. Release ACTION switch.

(t.1) Press and hold ACTION switch. Use SHC stick to drive TSU from stop to stop vertically. Verify that TSU can be driven stop to stop vertically in less than 4 seconds. Release ACTION switch.

(u) Position gunner armament control panel TSU/GUN SLEW RATE switch to LOW.

(v) Press and hold ACTION switch. Use SHC stick to drive TSU from stop to stop horizontally. Verify that TSU can be driven stop to stop horizontally in less than 63 seconds. Release ACTION switch.

(v.1) Press and hold ACTION switch. Use SHC stick to drive TSU from stop to stop vertically. Verify that TSU can be driven stop to stop vertically in less than 27 seconds. Release ACTION switch.

(w) Return STOW/TRK/ACQ switch to STOW.

**(3) Helmet sight tracking.**

(a) Position MASTER ARM switch on pilot panel to STBY.

(b) Connect helmet sight linkages to the BUILT-IN TEST (BIT) brackets.

(c) Position HSS BIT switch on gunner control panel to BIT and release. Check that a GO indication appears on HSS test indicator.

#### NOTE

**Completion of BIT circuit requires approximately two seconds.**

(d) Connect pilot and gunner linkages to their respective helmets and check for freedom of movement in all directions. Adjust helmet sight reticle on helmet until full reticle pattern can be seen.

(e) Position STOW/TRK/ACQ switch to TRK. Position ACQ switch to PHS and check that gunner helmet sight reticle retracts automatically. Check that TSU follows pilot helmet sight as it is aimed to left, right, up, and down. Release ACQ switch.

(f) If installed, return gunner helmet sight reticle to the down position.

(g) Hold STOW/TRK/ACQ switch in ACQ position. Verify that TSU follows gunner helmet sight as it is aimed to left, right, up, and down. Release STOW/TRK/ACQ switch and check that gunner helmet sight reticle retracts.

(h) Position STOW/TRK/ACQ switch to STOW. Observe that TSU returns to 0.0 position.

**(4) Steering commands and constraints tests.** Pilot steering commands on the HUD are a function of the TSU azimuth and elevation gimbal angles. In the prelaunch mode, the TSU LOS for azimuth steering commands is biased 0.75 degree right for left side missiles and 0.75 degree left for right side missiles. This bias is displayed on the HUD by offsetting the apparent TSU LOS reticle approximately 1/3 of the distance across either half of the TOW prelaunch mode limits display. Logic prevents prefiring a TOW missile until LOS rate, gimbal angle, attack logic, launcher position status and roll constraints are satisfied. After launch there is no bias.

(a) Position HUD PWR switch to ON and MODE switch to NORM.

(b) Position TCP MODE SELECT switch to ARMED MAN.

(c) Position pilot MASTER ARM switch to ARM.

(d) Position SHC STOW/TRK/ACQ switch to TRK and MAG switch to HI.

(e) Select missile No. 1 or any other odd-numbered missile position which indicates a missile present. Using the SHC, adjust the TSU position for the azimuth and elevation LOS to be approximately zero with respect to the ADL.





(f) Depress LHG ACTION switch: Note that the TOW prelaunch window is displayed on HUD.

(g) Verify that the TSU LOS reticle on the HUD is approximately 1/3 of the distance to the right of the ADL to the edge of the prelaunch limits when the AZ and EL LOS is zero.

(h) Release LHG ACTION switch.

(i) Select missile No. 2 or any other even-numbered missile position which indicates a missile present.

(j) Repeat steps (a) and (b).

(k) Verify that the TSU LOS is biased by the same amount to the left of the ADL when the AZ and EL LOS is zero.

(l) Move the TSU LOS through azimuth and elevation; observe that the HUD indicates the corresponding movement of the TSU LOS.

(m) Move the TSU LOS slowly to the right until the TSU LOS reticle falls outside the prelaunch window and verify that the reticle flashes.

(n) Move the TSU LOS slowly to the left. Verify that the reticle stops flashing when it is inside the prelaunch window and that it starts flashing again as it moves outside the prelaunch window on the left side. Verify that an X appears on the reticle at  $\pm 3.75^\circ$  azimuth or  $\pm 7.5 - 8^\circ$  elevation which are the limits of travel for the TSU LOS.

(o) Release LHG ACTION switch.

(P) Return the STOW/TRK/ACQ switch to STOW.

(q) Position TCP MODE SELECT switch to OFF.

(q.1) **MCN** Position FCP OFF/ON/BIT switch to OFF.

(r) Position pilot MASTER ARM switch to OFF.

(s) Position HUD PWR switch to STBY.

#### (5) Launcher/TSU alignment and slaving test.

(a) Apply hydraulic power to helicopter. Position TCP MODE SELECT switch to ARMED MAN and MASTER ARM switch to ARM on pilot armament control panel. Position TSU MAG switch to HI. Position HUD PWR switch to ON and HUD MODE switch to NORM.

(b) Select missile No. 1 on the TCP. Verify that the missile status indicator on the TCP for missile No. 1 indicates MSL and the TOW missile selection indicator appears on the HUD display outside the upper left corner of the prelaunch limit display.

(c) Set STOW/TRK/ACQ switch on SHC to TRK and track TSU to 0 degrees azimuth and 0 degrees elevation.

(d) Press and hold ACTION switch on LHG. Verify that only left launcher is slaving to TSU LOS in elevation.

(e) Drive TSU up slowly in elevation until TSU LOS reticle falls outside the inner rectangle. Verify that TSU LOS reticle flashes.

#### NOTE

**The alignment procedures may have to be accomplished before the HUD will operate properly.**

(f) Recenter the TSU LOS reticle within the prelaunch window and verify that it stops flashing. Drive the TSU down slowly until the TSU LOS reticle falls below the prelaunch window and verify that the reticle flashes.

(g) Select missile No. 2 and repeat steps (a) through (f), verifying the action of the right launcher, and the right missile select indicator on the HUD.

(6) **Armament control tests.** Operation during the preparation for launch and guidance of a missile shall be verified as follows:

(a) Pilot turret control and firing while in the TOW mode.

1 Position WPN CONTR switch on pilot armament control panel to PILOT and MASTER ARM switch to ARM.

**2** With MODE SELECT switch on TCP in any of the TOW modes (STBY TOW, ARMED MAN, or ARMED AUTO) and STOW/TRK/ACQ switch on SHC in either TRK or STOW, check that gunner PILOT IN CONT indicator is illuminated and that pilot can fire the turret weapon while using his helmet sight.

**3** Position the WPN CONTR switch to GUNNER and repeat step 2.

**(b) TSEM operating procedure.** Installation and operation of the TSEM shall be as follows:

**1** After loading the TSEM into launcher and lowering the arming lever, position POWER switch to ON. Check that POWER light and SHEAR PIN light illuminate.

**2** Position SELF TEST switch to AUTO and press RESET button.

**3** When TSEM is fired in a normal sequence, the following will be observed on rear panel of the TSEM:

**a** The START and WIRE SIGNAL AMPL lights illuminate simultaneously, the PREFIRE and -12 lights illuminate in sequence.

**b** The YAW, PITCH, FIRE, MSL GONE, and ZERO lights illuminate in sequence.

**c** The WIRE CUT and SQUIB DISC lights then illuminate and WIRE SIGNAL AMPL light extinguishes.

**d** The previously mentioned lights will remain illuminated until RESET button is depressed, Exception: the SHEAR PIN light will remain illuminated until launcher arming lever is raised.

#### NOTE

**In the first simulated firing following TMS turn on, or following a BIT sequence, the PITCH and YAW balance lights may not illuminate. This should not be interpreted as an abnormal firing sequence unless the PITCH and YAW lights fail to illuminate on successive firings.**

**4** At the end of test, or when use of TSEM is not called for in a test, or when TSEM is to be down loaded, position POWER switch to OFF. (An

unpowered TSEM loaded into a launcher will not affect the outcome of tests not requiring the TSEM.)

**(c) Manual missile selection and firing.**

#### NOTE

**Shearpin depression limits must be within tolerance for the launcher to be acceptable for firing. Both pods of all launchers must be verified. To avoid a double effort, check the upper outboard position last.**

**1** Move launcher armament control handle to up position.

**2** Turn TSEM to ON and press reset button.

**3** Connect TSEM power cable to TSEM and to DC power connector located in the ammunition bay.

**4** Position TSEM mode select switch to AUTO and power switch to ON.

**5** Press TSEM RESET switch and verify that power lamp is illuminated.

**6** Rotate mode select switch to LAMP TEST and verify that all TSEM lamps illuminate.

**7** Rotate mode select switch to SP "GO" and verify that shearpin lamp illuminates.

**8** Rotate launcher armament control handle to ARMED position and secure it with the captive locking pin. Verify that shearpin lamp goes out.

**9** Rotate TSEM mode select switch to SP "GO" and verify that shearpin lamp illuminates. If shearpin lamp does not illuminate, this launcher position should not be used until readjustment and verification of shearpin depression is accomplished.

**10** Push RESET button.

**11** Position MASTER ARM switch on pilot armament control panel to ARM. Set HUD power switch to ON and MODE switch to NORM.

**12** Position MODE SELECT switch on TCP to ARMED MAN. Verify that MISSILE SELECT switch is on missile position No. 1.

**13** Verify that missile status indicator on TCP for missile No. 1 indicates MSL.

**14** Set STOW/TRK/ACQ switch on SHC to TRK.

**15** Set MAG switch on LHG to HI.

**16** Press LHG ACTION switch. Verify the appearance of A flag in the eyepiece of TSU and the prelaunch window and TSU LOS reticle on the HUD.

#### NOTE

**Within constraint limitations means that the elevation and azimuth needles are within the inner rectangle and the ascend and descend pointers are not visible.**

**17** While observing the HUD, maintain the LOS reticle within window limits using SHC tracking stick. Verify that R flag is visible in the eyepiece of TSU.

**18** Position TSEM mode select switch to MSL GONE. Verify that R flag disappears in the eyepiece of TSU and that the post launch window replaces the prelaunch window on the HUD. Position TSEM mode select switch to AUTO.

#### NOTE

**The ACTION and trigger switch on the pilot cyclic grip will be depressed and held through steps 19 through 21. Read all of these steps before depression of the trigger.**

**19** Hold pilot helmet sight at 0 degree elevation and 0 degree azimuth and press pilot cyclic stick ACTION and trigger switch. Verify that turret weapon fires.

**20** Press the trigger and ACTION switch on LHG. Verify that turret weapon firing is interrupted.

**21** Verify that turret weapon resumes firing after a time delay of **2.8 TO 3.2** seconds. Release pilot cyclic grip trigger and ACTION switch. Release LHG trigger and ACTION switch.

**22** Verify the appearance of postlaunch window on the HUD. The window will disappear at completion of firing sequence, approximately 23 seconds.

**23** Using the TSEM, verify that a proper firing sequence takes place. Lights on TSEM will show proper sequence according to subparagraph (b) 3 above.

**24** Verify that indicator for missile No. 1 on TCP switches from MSL to barber pole pattern.

**25** When the postlaunch window disappears, press RESET button on TSEM and verify that the indicator for missile No. 1 on the TCP again indicates MSL.

**26** Press and hold ACTION switch on the LHG and drive the TSU LOS out of constraints in elevation. Pull trigger to confirm missile will not fire.

**27** Press CONST OVRD switch on the SHC. Verify the appearance of the A flag in the eyepiece of the TSU and prelaunch window on the HUD. RDY flag should not appear.

**28** Momentarily press the TRIGGER on the LHG. The ACTION switch may be released with the TRIGGER switch.

**29** Reset the TSEM and with the TSU LOS reticle in constraints, pull ACTION switch and TRIGGER switch on LHG. Push gunner WIRE CUT switch and observe wire cut indicator on TSEM.

**29.1 MCN** Repeat step 29 using LHG WIRE CUT switch.

**30** Repeat step 29 using pilot wire cut button.

**31** Remove TSEM from missile position No. 1, cycle (install) the TSEM through the remaining missile positions, and repeat steps 3 through 31 for each position selected.

#### (d) Automatic selection and firing.

**1** Install TSEM in missile position No. 1.

**2** Set mode select switch on TSEM to **AUTO**.

**3** Set MASTER ARM switch on pilot armament control panel to ARM. Set MODE SELECT switch on TCP to ARMED AUTO. Set HUD PWR switch to ON and MODE switch to NORM.

**4** Set STOW/TRK/ACQ switch on SHC to TRK.

5 Set MAG select switch on LHG to HI.

6 Press the LHG ACTION switch and, by observing the HUD, maintain the TSU LOS reticle within maneuver constraints.

7 Momentarily press the TRIGGER on the LHG. Note the completion of the firing sequence by observing that an X appears over the missile image selected, then disappears with the prelaunch window. The postlaunch window replaces the prelaunch window on the HUD, then disappears at wire cut. Verify that the TSEM firing sequence is in accordance with (b)3 above.

8 Return the STOW/TRK/ACQ switch to STOW.

9 Check that the MISSILE SELECT switch on the TCP has automatically selected missile No. 2 or the next available missile. Check HUD for correct L-R TOW indication.

10 Repeat steps 5 through 9 for all remaining missile positions. Verify that the HUD and TCP indications are normal and verify the test firing sequence defined by Figure 9-29.

11 For missile position No. 8, set TCP CAMERA switch to AUTO. Verify that camera operations (if available) start when the LHG TRIGGER is pressed and stop with the loss of the postlaunch window on the HUD.

12 Position gunner PLT ORIDE switch to PLT ORIDE. Observe that TCP system status indicator moves to OFF.

13 Turn TSEM off.

14 Place pilot MASTER ARM in OFF, PLT ORIDE in OFF, and TCP MODE SELECT switch in STBY TOW.

15 Turn CAMERA (if available) switch to OFF.

16 Position HUD power switch to OFF.

**d. Conclusion of Tests.** Upon completion of the preceding tests, de-energize and disconnect auxiliary power unit and hydraulic ground test cart. Remove TSEM from launcher.

## 9-527. **M MCN TROUBLESHOOTING - M65 OR M65/C-NITE TOW MISSILE SUBSYSTEM CIRCUITRY.**

a. For troubleshooting procedures, refer to TM 55-1520-236-T.

b. **M65 TOW missile subsystem.** Troubleshooting of the M65 TOW missile subsystem is accomplished during BIT (built-in test) procedures and also by use of Test Set, Guided Missile System (TSGMS). Refer to TM 9-1425-473 series maintenance manuals for troubleshooting procedures.

## 9-528. **M SERVO ELECTRONIC CONTROL UNIT (SECU).**

### 9-529. **M DESCRIPTION - SERVO ELECTRONIC CONTROL UNIT (SECU).**

The servo electronic control unit (SECU) provides regulated power and contains signal switching, servo amplifier, logic, and buffering circuitry necessary to align the pitch angle of the TOW missile launchers with the pitch angle of the line-of-sight (LOS) of the telescopic sight unit (TSU). Slaving of the two pitch angles ensures that the TOW missile will reliably enter the field of view of the infrared receiver of the TSU. The TOW missile can be guided to target only if the initial launch thrust positions the missile within this field of view. During the attack mode, when the gunner selects a missile for firing, the launcher containing the selected missile is activated. Upon activation, the SECU initial command drives the launcher up. Angular position signals from the TSU resolver are routed to the SECU, processed through buffer amplifier stages, then applied to the respective launcher resolver. The launcher resolver output provides position feedback to the servo amplifier loop, and the accelerometer provides launcher acceleration feedback to the servo amplifier loop. The servo amplifier output to the hydraulic actuator servo coil allows the hydraulic actuator to change the pitch angle of the activated launcher when hydraulic pressure is provided to the actuator. The SECU also has a detector circuit which decreases the servo amplifier gain when the launcher approaches the mechanical elevation stop at either extreme. Hydraulic pressure is applied to the activated launcher through the hydraulic solenoid valve and the launcher pitches from stow position to the correct

pitch angle relative to the TSU LOS. When fired, the missile is launched into the field of view of the infrared receiver, and wire transmitted command signals from the M65 guidance and command functional group steers the missile along the TSU LOS. After launch, the SECU activate signal ceases and the launcher is returned to stow position. The hydraulic solenoid is turned off after a delay of  $1.5 \pm 0.75$  seconds. The SECU is located on forward bulkhead of the oil cooler compartment. (Refer to paragraph F-9 in Appendix F for equipment location charts).

### 9-530. **M** CLEANING - SERVO ELECTRONIC CONTROL UNIT (SECU).

- a. Remove moisture and loose dirt with a clean, soft cloth.

#### **WARNING**

Cleaning solvent is flammable and toxic. Provide adequate ventilation. Avoid prolonged breathing of solvent vapors and contact with skin or eyes.

- b. Remove grease, fungus, and dirt with a clean, lint-free cloth dampened with dry cleaning solvent (C112).
- c. Remove dirt from electrical connectors with a bristle brush.

### 9-531. **M** INSPECTION - SERVO ELECTRONIC CONTROL UNIT (SECU).

- a. Inspect SECU case for cracks or dents.
- b. Inspect SECU for secure mounting.
- c. Inspect electrical connectors for broken pins or cracked inserts.
- d. Inspect printed wiring assemblies for cracked, broken, loose or missing hardware and components; burned components and wiring; cracked, chipped or broken wiring board.

### 9-532. **M** REMOVAL - SERVO ELECTRONIC CONTROL UNIT (SECU).

- a. Ensure all electrical power is OFF.
- b. Remove oil cooler compartment access panel.
- c. Disconnect electrical connectors from SECU. Protect receptacles and plugs with caps or electrical tape (C121).

- d. Remove mounting screws and washers securing SECU to structure and remove SECU.

- e. Loosen two screw assemblies on front of SECU. Open door assembly and slide printed wiring assemblies out, if required.

### 9-533. **M** REPAIR - SERVO ELECTRONIC CONTROL UNIT (SECU).

- a. Repair connectors, and tighten or replace loose or missing mounting screws.
- b. Replace SECU if case is damaged or defective. Evacuate removed SECU to higher maintenance level for disposition.
- c. Replace printed wiring assemblies as required.

### 9-534. **M** INSTALLATION - SERVO ELECTRONIC CONTROL UNIT (SECU).

- a. Position SECU in place on forward wall of oil cooler compartment with electrical jacks down and secure with four mounting screws and washers.
- b. Remove protective caps or electrical tape from connectors and connect to respective receptacles on SECU.
- c. Close and secure oil cooler compartment access panel or screen.
- d. Install printed wiring assembly in SECU case. Close door and fasten two screw assemblies.

### 9-535. **M** WING STORES ARMAMENT SYSTEMS CIRCUITRY.

### 9-536. **M** DESCRIPTION - WING STORES ARMAMENT SYSTEMS CIRCUITRY.

The wing stores armament systems consist of the XM138 rocket management subsystem circuitry, XM18 minigun circuitry, and wing stores jettison circuitry.

### 9-537. **M** XM138 ROCKET MANAGEMENT SUBSYSTEM CIRCUITRY.

### 9-538. **M** DESCRIPTION - ROCKET MANAGEMENT SUBSYSTEM CIRCUITRY.

The rocket management subsystem circuitry enables the pilot to determine the number of rockets on-board before and after firing, select the warhead and fuze

type, set the fuze to compensate for forest canopy or bunker cover thickness to be penetrated, select the rate at which the rockets will be fired, select singles, pairs, or quads, select the total number of rockets to be fired, select the range in meters, and to launch the rockets from rocket launchers mounted on any or all of the four wing stations. With the systems armed, rockets may be launched by pressing either the pilot WING ARM FIRE switch or gunner WING ARM FIRE switch (when in PLT ORIDE mode).

**9-539. M FUNCTIONAL TEST - ROCKET MANAGEMENT SUBSYSTEM CIRCUITRY.**

The following functional test of the XM138 rocket management subsystem (RMS) is designed to be performed using the RMS on-board built-in test (BIT) (figures 9-30 and 9-31).

**WARNING**

Ensure no live ammunition is present in any of the armament systems.

- a. Open all circuit breakers and place all switches to their OFF or de-energized positions.
- b. Connect a 28 Vdc external power source to helicopter external power receptacle and energize power source.
- c. Place pilot MASTER ARM switch in STBY position.
- d. Press the pilot RMS display unit TEST switch. The RMS BIT test will perform two routines when the TEST switch is pressed.

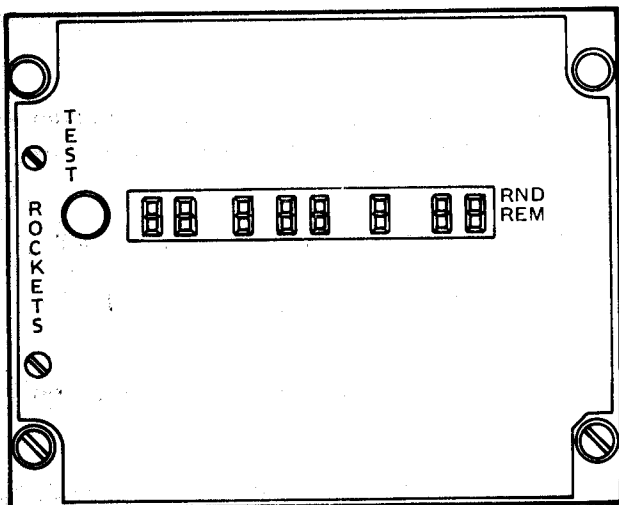

209075-408

Figure 9-30. M DU Digital Display Test

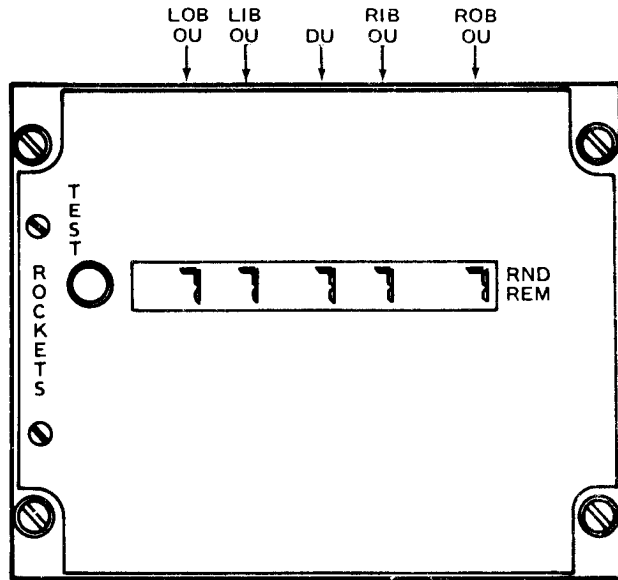

209075-407A

Figure 9-31. M LRU Fault Identification and Location Test

(1) The first routine is a digital display test and checks the display segments by lighting all segments and displaying a lighted eight (8) in all eight positions of the RND REM Panel on the display unit (DU). The RMS BIT will identify a fault during the first routine by displaying a number less than eight (8) in the position containing the fault (figure 9-30).

(2) The second routine is a line replaceable unit (LRU) fault identification and location test which automatically follows the first routine. This test provides for the detection and isolation of any LRU (DU and four operations units) malfunction and non-compliant verification of LRU functions. Test results are visually displayed on the RND REM panel of the pilot display panel. If all LRUs are functioning properly as determined by the test routine the number seven (7) will be displayed for each of the five LRUs (figure 9-31). A malfunction or non-complaint of any LRU will cause the associated digital display to be blanked indicating the LRU should be replaced.

e. The BIT test may be performed at any time but ONLY if the MASTER ARM switch is in the STBY position. Switching to the ARM position will override the TEST switch and terminate any test in progress, returning the system to normal operation.

f. An additional verification of the defective LRU will be the activation of the equipment status indicator flag on the malfunction LRU.

(1) The equipment status indicator flags permit the last LRU status to be displayed after primary power outages or after primary power has been removed.

(2) The equipment status indicators are magnetic-latching and mechanically resettable.

## 9-540. **M** TROUBLESHOOTING - XM138 ROCKET MANAGEMENT SUBSYSTEM CIRCUITRY.

### NOTE

A filter (21A121) is installed between airframe wiring and display unit to prevent excessive noise in fm radio system. If a noise problem exists in fm radio system, turn RMS off to determine if filter is defective. Replace filter if required.

a. For troubleshooting procedures, refer to TM 55-1520-236-T.

b. **XM138 Rocket Management Subsystem.** Troubleshooting of the XM138 rocket management subsystem is accomplished during BIT (built-in-test) procedure.

## 9-541. **M** OPERATIONS UNITS (OU).

## 9-542. **M** DESCRIPTION - OPERATIONS UNITS (OU).

The operations units receive electrical command signals from the integrated control and display unit. The station unit evaluates the information and provides the proper signals to set the fuzes on the rockets for desired running time and to provide power for the electronic circuitry.

## 9-643. **M** CLEANING - OPERATIONS UNIT (OU).

a. Remove moisture and loose dirt with a clean, soft cloth.

## WARNING

**Cleaning solvent is flammable and toxic, Provide adequate ventilation. Avoid prolonged breathing of solvent vapors and contact with skin or eyes.**

b. Remove grease, fungus, and dirt with a clean, lint-free cloth dampened with dry cleaning solvent (C112).

c. Remove dirt from electrical connectors with a bristle brush.

## 9-544. **M** INSPECTION - OPERATIONS UNIT (OU).

a. Inspect OU case for cracks or damage.

b. inspect electrical connector for damaged pins and cracked connector inserts or hood.

c. Inspect OU for secure mounting.

## 9-545. **M** REMOVAL - OPERATIONS UNIT (OU).

a. Insure all electrical power is off.

b. Remove OU access panel(s) (Outboard and inboard leading edge access panels on the left and right wing).

c. Disconnect two electrical connectors from each OU. Protect receptacles and plugs with caps or electrical tape (C121).

d. Remove four mounting bolts and washers to remove the OU from the wing leading edge bulkhead.

## 9-546. **M** REPAIR - OPERATIONS UNIT (OU).

a. Repair connectors, and tighten or replace loose or missing mounting or assembly screws or bolts.

b. Replace OU if case is damaged or defective. Evacuate removed OU to next higher echelon for repair or disposition (TM 9-1270-217-13&P).

**9-547. M INSTALLATION - OPERATIONS UNIT (OU).**

a. Position OU on the wing leading edge bulkhead and install mounting bolts and washers.

b. Remove protective caps or electrical tape from two electrical connectors and install on OU.

**9-548. M XM18 MINIGUN CIRCUITRY.**

**9-549. M DESCRIPTION - XM18 DESCRIPTION - XM18 MINIGUN CIRCUITRY.**

The XM-18 minigun circuitry enables the pilot or gunner (when in PLT ORIDE mode) to select and fire either or both XM-18 miniguns mounted on inboard wing stations. With the system armed, either or both miniguns may be fired by pressing either the pilot WING ARM FIRE switch or gunner WING ARM FIRE switch (when in PLT ORIDE mode).

**9-550. M FUNCTIONAL TEST - XM18 MINIGUN CIRCUITRY.**

The following functional test of the XM18 minigun circuitry is designed to be performed using a test set as indicated in figure 9-32, or a suitable equivalent.

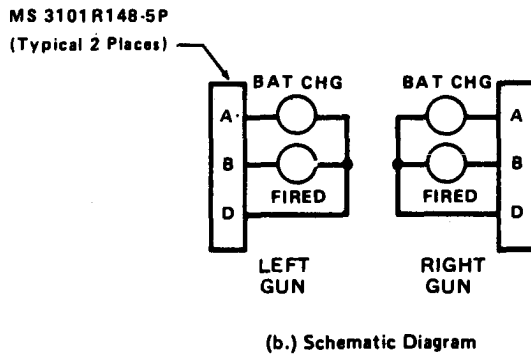
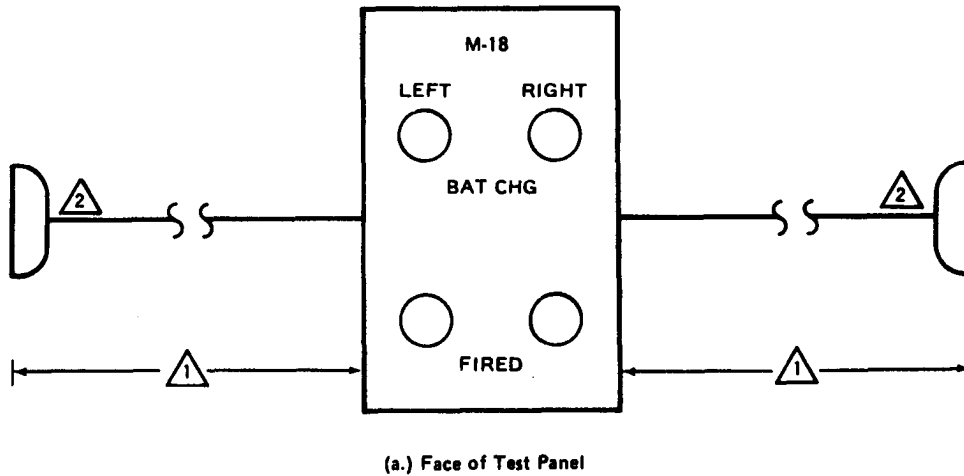

- NOTES:
- 1 Cable length as required.
  - 2 Connectors to mate with 21A10P1 and 21A11P1.

209475-510

**Figure 9-32. M XM18 Minigun Circuitry Test Panel**





**Ensure no live ammunition is present in any of the armament systems. Only dummy ammunition with smooth cases like live ammunition shall be used.**

- a. Open all circuit breakers and place all switches to their OFF or de-energized positions.
- b. Connect the two XM18 test set cables to connectors (21A10P1 and 21A11P1) at inboard wing stores disconnect area in wings on the helicopter.
- c. Connect a 28 Vdc external power source to helicopter external power receptacle and energize power source.
- d. Close WPN CONT, RH GUN, and LH GUN circuit breakers.

e. Place WPN CONTR switch on pilot ARMT panel in PILOT position. Check that no lights are illuminated on the test set.

f. Perform steps 1 through 15 in the XM18 minigun checkout chart, table 9-41.

g. Place WPN CONTR switch on pilot ARMT panel in GUNNER position.

h. Perform steps 1 through 15 in the XM18 minigun checkout chart, table 9-41.

i. With the turret gun installed and operational, position turret full left and perform steps 7,8, 11, 12, 13, and 15 in the XM18 minigun checkout chart, table 9-41. No FIRED light shall illuminate.

j. With the turret gun installed and operational, position turret full right and perform steps 7, 8, 11, 12, 13, and 15 in the XM18 minigun checkout chart, table 9-41. No FIRED light shall illuminate.

**Table 9-41. M XM18 Minigun Checkout Chart**

Step	Pilot WING STORE Switch	Gunner WING STORE Switch	Pilot WING ARM FIRE Switch	Gunner WING ARM FIRE Switch	Pilot ORIDE Switch	MASTER ARM Switch	Test Set BAT CHG Lights	Test Set FIRED Lights
1	GUN	either			OFF	STBY	on	off
2	GUN	GUN	fire		OFF	STBY	on	off
3	GUN	GUN		fire	OFF	STBY	on	off
4	GUN	GUN	fire		OFF	OFF	on	off
5	GUN	GUN		fire	OFF	OFF	off	off
6	GUN	RKT	fire release		OFF	ON	off	on off
7	GUN	GUN	fire release		OFF	ON	off	on off
8	RKT	GUN	fire		OFF	ON	off	off
9	GUN	GUN	fire		ON	ON	off	off
10	GUN	RKT	fire		ON	ON	off	off

Table 9-41. **M** XM18 Minigun Checkout Chart (Cont)

Step	Pilot WING STORE Switch	Gunner WING STORE Switch	Pilot WING ARM FIRE Switch	Gunner WING ARM FIRE Switch	Pilot ORIDE Switch	MASTER ARM Switch	Test Set BAT CHG Lights	Test Set FIRED Lights
11	RKT	GUN		fire release	ON	ON	off	on off
12	GUN	GUN		fire release	ON	ON	off	on off
13	GUN	GUN		fire release	OFF	ON	off	on off
14	GUN	RKT		fire	ON	ON	off	off
15	RKT	GUN		fire release	OFF	ON	off	on off

**9-551. **M** TROUBLESHOOTING - XM18 MINIGUN CIRCUITRY.**

Refer to paragraph F-9 in Appendix F for wiring diagram. Use Table 9-42 and perform checks as necessary to isolate trouble. In the following table,

tripped circuit breakers are omitted from indications of trouble. Such trouble is usually easily detected and corrected. Broken wiring is always a probable cause of circuit malfunction or failure and has not been included.

**NOTE**

**Before you use this table, be sure you have performed all normal operational checks. If you have a malfunction which is not listed in this table, notify the next higher level of maintenance.**

Table 9-42. **M** Troubleshooting XM18 Minigun Circuitry

CONDITION	TEST OR INSPECTION	CORRECTIVE ACTION
		<ol style="list-style-type: none"> <li>With switch breakers on AC/ARMT circuit breaker panel in WPN FIRE, LH GUN, and RH GUN positions, MASTER ARM switch in ARM, and WING STORE switch in GUN, XM 18 miniguns do not fire when pilot WING ARM FIRE switch is pressed.</li> </ol> <p>STEP 1. Check for defective wiring.</p> <p><b>If defective, repair wiring.</b></p>

Table 9-42. **M** Troubleshooting Troubleshooting XM18 Minigun Circuitry (Cont)

## CONDITION

## TEST OR INSPECTION

**CORRECTIVE ACTION**

STEP 2. Check for defective master arm relay (19K31).

**If defective, replace relay (paragraph 9-16).**

STEP 3. Check for defective WING ARM FIRE switch.

**If defective, replace switch (paragraph 9-16).**

STEP 4. Check for defective WING ARM FIRE switch on pilot cyclic stick.

**Handle in accordance with instructions pertinent to the cyclic stick (paragraph 11-30).**

2. With switch breakers on AC/ARMT circuit breaker panel in WPN FIRE, LH GUN, and RH GUN, MASTER ARM switch in ARM, and WING STORE switch in GUN, one XM18 minigun fires, but the other does not fire.

STEP 1. Check for defective ground connection to airframe on the side which does not fire.

**If defective, repair ground connection.**

STEP 2. Check for defective wiring.

**If defective, repair wiring.**

STEP 3. Check for defective wing disconnect connector (21J1-21P1 or 21J2-21P2) on the side which does not fire.

**If defective, replace connector (paragraph 9-16).**

STEP 4. Check for defective LH GUN or RH GUN switch breaker which controls the side that does not fire.

**If defective, replace circuit breaker (paragraph 9-23).**

3. With switch breakers on AC/ARMT circuit breaker panel in LH GUN and RH GUN, TURRET PWR circuit breaker closed, PILOT ORIDE switch in PILOT ORIDE, and WING STORE switch in GUN, neither XM18 minigun fires when WING STORES FIRE switch on gunner cyclic stick is pressed.

STEP 1. Check for defective wiring.

**If defective, repair wiring.**

STEP 2. Check for defective ARMT CONTR circuit breaker.

**If defective, replace circuit breaker (paragraph 9-23).**

STEP 3. Check for defective WING STORES FIRE switch on gunner cyclic stick.

**Handle in accordance with instructions pertinent to the cyclic stick (paragraph 11-54).**

Table 9-42. **M** Troubleshooting XM18 Minigun Circuitry (Cont)

CONDITION

TEST OR INSPECTION

**CORRECTIVE ACTION**

STEP 4. Check for defective connector (21A9P1), (21A8P1), (21J1-21P1), (21J2-21P2).

**If defective, replace connector (paragraph 9-16).**

STEP 5. Check for defective turret system circuitry.

**Refer to TM9-1090-206 series maintenance manuals.**

4. With TURRET CONTR circuit breaker and minigun switch breakers in LH GUN and RH GUN positions, PILOT ORIDE switch positioned to PILOT ORIDE, and WING STORE switch in GUN position, one XM18 minigun fires, but the other does not fire when gunners WING STORES FIRE switch is pressed.

STEP 1. Check for defective wiring.

**If defective, repair wiring.**

STEP 2. Check for defective ARMT CONTR circuit breaker.

**If defective, replace circuit breaker (paragraph 9-23).**

STEP 3. Check for defective WING STORES FIRE switch on gunner cyclic stick.

**Handle in accordance with instructions pertinent to the cyclic stick (paragraph 11-54).**

STEP 4. Check for defective connector (21A10P1), (21A11P1), (21J1-21P1), (21J2-21P2).

**If defective, replace connector (paragraph 9-16).**

STEP 5. Check for defective turret system circuitry.

**Refer to TM9-1090-206 series maintenance manuals.**

**9-652. **M** WING STORES JETTISON CIRCUITRY.**

**9-653. ~ DESCRIPTION - WING STORES JETTISON CIRCUITRY.**

The wing stores jettison circuitry enables the pilot to select wing station weapons (inboard or outboard) to be jettisoned in an emergency situation. Selected wing station weapons are jettisoned by pressing the pilot or gunner WING STORES JETTISON switch.

**9-554. **M** FUNCTIONAL TEST WING STORES JETTISON CIRCUITRY.**

The functional test of the wing stores jettison circuitry is designed to be performed using a test set as indicated in figure 9-33, or equivalent.

- a. Open all circuit breakers and place all switches to their OFF or de-energized positions.

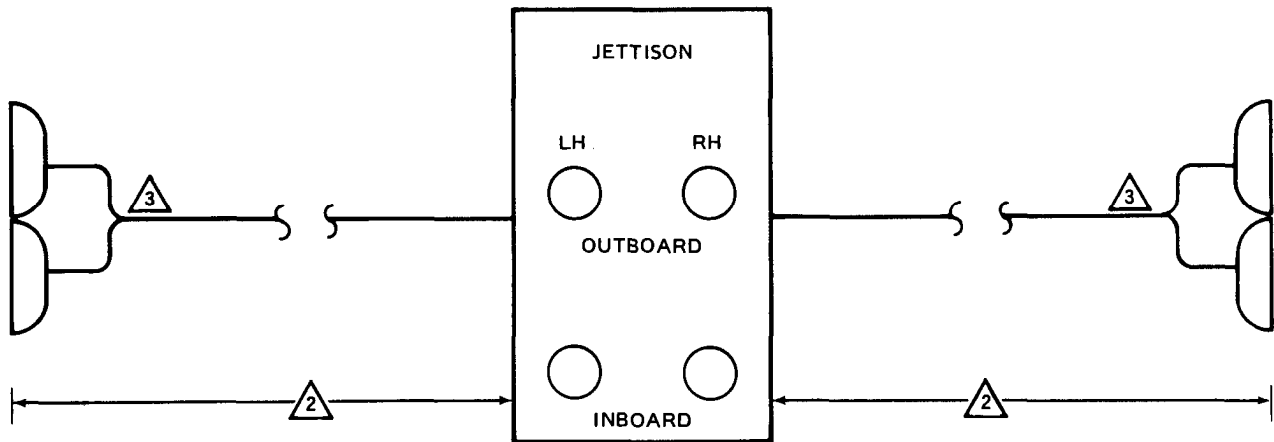

(a.) Face of Test Panel

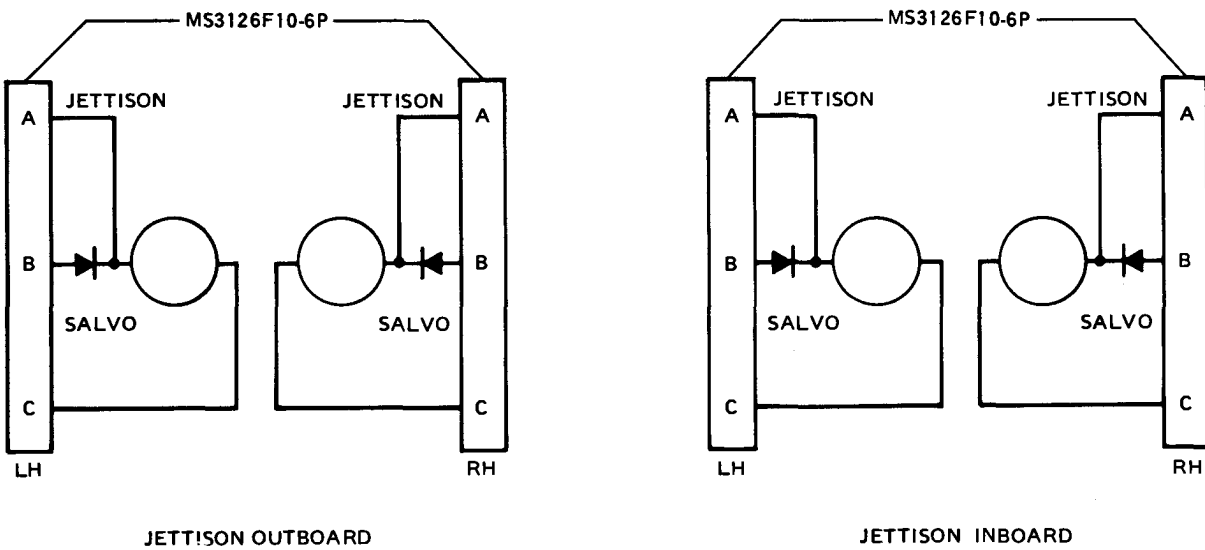

(b.) Schematic Diagram

**NOTES:** 1. All wires to be 20 gauge.  
 All lamps MS25237-327 or equivalent.  
 2. Cable length as required.

3. Connectors to mate receptacles 21SQ1J1, 21SQ2J1, 21SQ3J1, and 21SQ4J1, respectively.

**SCALE:** None

209475-509

Figure 9-33. **M** Wing Stores Circuitry Test Panel

b. Connect wing stores jettison test set cables to respective helicopter receptacles (21SQ1J1, 21SQ2J1, 21SQ3J1, and 21SQ4J1).

c. Connect a 28 Vdc external power source to helicopter external power receptacle and energize power source.

d. Ensure that JETTISON SELECT switches on pilot miscellaneous panel are in OFF position.

e. Ensure that WING STORE JETTISON switch on gunner instrument panel is in the down position and that metal guard is in place over the switch toggle.

f. Place WING STORES switch breakers on AC/ARMT circuit breaker panel to PLT JETT and GNR JETT. Check that no JETTISON lights on test set are illuminated and perform the checkout procedures, in wing stores jettison checkout chart, table 9-43.

**Table 9-43. M Wing Stores Jettison Checkout Chart**

Step	Pilot OUTBD JETTISON SELECT Switch (21S5)	Pilot INBD JETTISON SELECT Switch (21S4)	Gunner JETTISON SELECT Switch (21S2)	Pilot JETTISON Switch (s1S3)	Gunner JETTISON Switch (21S1)	Results Test Set Jettison Lights
1	Close PLT JETT circuit breaker.					No test set jettison lights
2	OFF	OFF	BOTH	Depress & Release	OFF	No test set jettison lights
3	OFF	OFF	INBD	Depress & Release	OFF	No test set jettison lights
4	OFF	OFF	OUTBD	Depress & Release	OFF	No test set jettison lights
5	OUTBD	OFF	BOTH	Depress & Release	OFF	Outboard lights illuminate & extinguish approximately 0.5 seconds later
6	OFF	INBD	BOTH	Depress & Release	OFF	Inboard lights illuminate and extinguish approx. 0.5 seconds later
7	OUTBD	INBD	BOTH	Depress & Release	OFF	Outboard and inboard lights illuminate and extinguish approx. 0.5 seconds later
8	OUTBD	INBD	BOTH	Released	JTSN	No test set jettison lights
9	OUTBD	OFF	BOTH	Released	JTSN	No test set jettison lights

Table 9-43. **M** Wing Stores Jettison Checkout Chart (Cont)

Step	Pilot OUTBD JETTISON SELECT Switch (21S5)	Pilot INBD JETTISON SELECT Switch (21S4)	Gunner JETTISON SELECT Switch (21S2)	Pilot JETTISON Switch (21S3)	Gunner JETTISON Switch (21S1)	Results Test Set Jettison Lights
10	OFF	INBD	BOTH	Released	JTSN	No test set jettison lights
11	OFF	OFF	BOTH	Released	OFF	No test set jettison lights
12	Close GNR JETT circuit breaker.					No test set jettison lights
13	OFF	OFF	INBD	Released	JTSN	Inboard lights illuminate
14	OFF	OFF	OUTBD	Released	JTSN	Outboard lights illuminate
15	OFF	OFF	BOTH	Released	JTSN	Outboard and inboard lights illuminate
16	Insert jumper wires between pins A & C for both connectors 20P8J01 & 20S8J01					
17	OFF	INBD	BOTH	Depress & Release	OFF	Outboard lights illuminate and extinguish approx. 0.5 seconds later
18	OFF	OFF	INBD	Released	JTSN	Outboard lights illuminate and remain illuminated
19	Repeat Step 13					
20	Open GNR JETT circuit breaker					
21	Repeat Steps 1,2,3,4,7,8,9,&10					
22	Repeat Step 5					No test set jettison lights
23	Repeat Step 6					Only outboard lights illuminate and extinguish approximately 0.5 seconds later

Table 9-43. **M** Wing Stores Jettison Checkout Chart (Cont)

Step	Pilot OUTBD JETTISON SELECT Switch (21S5)	Pilot INBD JETTISON SELECT Switch (21S4)	Gunner JETTISON SELECT Switch (21S2)	Pilot JETTISON Switch (21S3)	Gunner JETTISON Switch (21S1)	Results Test Set Jettison Lights
24	Remove jumper wires from connectors 20P8J01 & 20S8J01					
25	Remove test set. Restore Wing stores wiring to normal configuration.					

**9-555. TROUBLESHOOTING - WING STORES JETTISON CIRCUITRY.**

Refer to paragraph F-9 in Appendix F for wiring diagram. Use Table 9-44 and perform checks as necessary to isolate trouble. In the following table,

tripped circuit breakers are omitted from indications of trouble. Such trouble is usually easily detected and corrected. Broken wiring is always a probable cause of circuit malfunction or failure and has not been included.

**NOTE**

**For troubleshooting procedures, refer to TM 55-1520-236-T and table 9-44 below.**

Table 9-44. **M** Troubleshooting Wing Stores Jettison Circuitry

**CONDITION**

TEST OR INSPECTION

**CORRECTIVE ACTION**

1. WING STORES JTSN and PLT JTSN circuit breakers are closed. Pilot JETTISON SELECT switches are positioned as required to jettison appropriate wing stores. Gunner JTSN SEL switch is in BOTH position and gunner JETTISON switch is in OFF position. The appropriate (outboard, inboard, or both) wing stores do not jettison when pilot collective JETTISON switch is depressed.

STEP 1. Check for defective wiring.

**Replace or repair wiring.**

STEP 2. Check for defective PLT JETT or WING STORES JTSN circuit breakers. (21CB1 and/or 21CB2).

**Replace defective circuit breaker(s) (paragraph 9-23).**



Table 9-44. **M** Troubleshooting Wing Stores Jettison circuitry (Cont)

## CONDITION

## TEST OR INSPECTION

**CORRECTIVE ACTION**

STEP 3. Check for defective pilot collective JETTISON switch (21S3).

**Replace defective switch (paragraph 9-16).**

STEP 4. Check for defective pilot JETTISON SELECT switches (21S4 and/or 21S5).

**Replace defective switch(s) (paragraph 9-16).**

STEP 5. Check for defective or incorrectly installed diodes (21CR3, 21CR4).

**Replace defective diodes (paragraph 9-16).**

STEP 6. Check for defective pilot jettison switch relay (21K3).

**Replace defective relay (paragraph 9-16).**

STEP 7. Check for defective jettison control relay (21K2) or pilot jettison control relay (21K4).

**Replace defective relay (paragraph 9-16).**

2. With conditions same as condition 1, appropriate wing stores are jettisoned on one side, but not on the other side when pilot collective JETTISON switch is depressed.

STEP 1. Check for defective wiring.

**Repair wiring, if defective (paragraph 9-16).**

STEP 2. Check for defective wing disconnect connectors (21J1/21P1, 21J3/21P3 or 21J2/21P2, 21J4/21P4) on side that does not jettison properly.

**Replace defective connector (paragraph 9-16).**

3. WING STORES JTSN, PLT JETT, and GNR JETT circuit breakers are closed. Pilot JETTISON SELECT switches are both positioned to OFF. Gunner JTSN SEL switch is positioned as required to jettison appropriate wing stores. Pilot collective JETTISON switch is released. The appropriate (outboard, inboard, or both) wing stores do not jettison when gunner JETTISON switch is positioned to JTSN.

STEP. 1 Check for defective wiring.

**Replace or repair wiring.**

STEP 2. Check for defective GNR JTSN circuit breaker (21CB5).

**Replace circuit breaker (paragraph 9-23).**

Table 9-44. **M** Troubleshooting Wing Stores Jettison Circuitry (Cont)

CONDITION

TEST OR INSPECTION

**CORRECTIVE ACTION**

STEP 3. Check for defective gunners JETTISON switch (21S1).

**Replete defective switch (paragraph 9-16).**

STEP 4. Check for defective gunner JTSN SEL switch (21S2).

**Replace defective switch (paragraph 9-16).**

STEP 5. Check for defective or incorrectly installed diodes (21CR5, 21CR6).

**Replace defective diodes (paragraph 9-16).**

STEP 6. Check for defective gunner jettison control relay (21K5).

**Replace defective relay (paragraph 9-16).**

STEP 7. Check for defective jettison control relay (21K2).

**Replace defective relay (paragraph 9-16).**

4. With conditions same as condition 3, appropriate wing stores are properly jettisoned on one side but not on the other side when gunner JETTISON switch is positioned to JTSN.

STEP 1. Check for defective wiring.

**Repair wiring, if defective.**

STEP 2. Check for defective wing disconnect connectors (21J1/21P1, 21J3/21P3) or (21J2/21P2, 21J4/21P4) on side that does not jettison properly.

**Replace defective connector (paragraph 9-16).**

**9 - 5 5 6 . **M** FIRE CONTROL COMPUTER (FCC).**

**9-557. **M** DESCRIPTION - FIRE CONTROL COMPUTER (FCC).**

The fire control computer (FCC) contains a 16 bit, parallel, general purpose, micro-programmable processor, memory, analog and digital interface, and power supply electronics housed in one unit. The FCC

provides continuous gun directing command signals proportional to the ballistic prediction angle, including compensation for effects of range, air density, helicopter pitch and roll, total velocity, and other effects to meet the weapons laying accuracy requirements. Ballistic corrections for aerial rocket fire include effects of rotor downwash, weather vaning, and time of flight. The FCC concurrently stores ballistic equations for eight different rockets and two turreted weapons. Simultaneous gun and

rocket solutions are provided. The FCC performs computations necessary for target position determination, weapon prediction angle compensation, boresight compensation, data for head up display (HUD) symbology, and built-in self test (BIT). The FCC interfaces, directly and also by means of auxiliary equipment, with all armament systems except the XM18 gun pods. Refer to TM9-1270-218-13 for maintenance information and procedures pertaining to FCC.

#### **9-558. M FUNCTIONAL TEST - FIRE CONTROL COMPUTER (FCC).**

Functional testing of the FCC is by BIT (built-in test) functions. Refer to TM9-1270-218-13 for functional test procedure.

#### **9-559. M TROUBLESHOOTING - FIRE CONTROL COMPUTER (FCC).**

a. For subsystem troubleshooting, refer to TM 55-1520-236-T.

b. FCC. Troubleshooting of FCC is by BIT (built-in test) functions. Refer to TM9-1270-218-13 for troubleshooting procedures.

#### **9-560. M HEAD UP DISPLAY SUBSYSTEM (HUDS) CIRCUITRY.**

#### **9-561. M DESCRIPTION - HEAD UP DISPLAY SUBSYSTEM (HUDS) CIRCUITRY.**

The HUDS circuitry generates aircraft situation and weapons aiming symbology which is projected into the pilot forward field of view. The subsystem interfaces with the M65 TOW missile subsystem, the radar altimeter, the fire control computer, and the caution panel on the pilot instrument panel. For description and additional information pertaining to HUDS components, refer to TM9-1270-220-13. Refer to TM9-1270-220-13 for maintenance information and procedures pertaining to HUDS components.

#### **9-562. M FUNCTIONAL TEST - HEAD UP DISPLAY SUBSYSTEM (HUDS).**

Functional testing of HUDS components and the interface with the fire control computer are tested by

BIT (built-in test) functions. The interfaces with the M65 missile subsystem and radar altimeter are tested by utilizing HUDS equipment in a simulated mission sequence and observing the HUDS display. Refer to TM9-1270-220-13 for functional test procedures.

#### **9-563. M TROUBLESHOOTING - HEAD UP DISPLAY SUBSYSTEM (HUDS) CIRCUITRY.**

b. HUDS. Troubleshooting of the HUDS is accomplished by BIT (built-in test) functions. Refer to TM9-1270-220-13 for troubleshooting procedures.

#### **9-564. M FIRE AND FLIGHT AIR DATA SUBSYSTEM CIRCUITRY.**

#### **9-565. M DESCRIPTION - FIRE AND FLIGHT AIR DATA SUBSYSTEM CIRCUITRY.**

The fire and flight air data subsystem (ADS) supplies digital true airspeed, absolute (static) pressure, and free-stream air temperature signals to the fire control computer. An analog radar altitude signal is fed to the ADS from the radar altimeter to provide ground effect correction. The ADS interfaces with the fire control computer and radar altimeter. Refer to TM9-1270-219-13 for maintenance information and procedures pertaining to ADS components.

#### **9-566. M FUNCTIONAL TEST - FIRE AND FLIGHT AIR DATA SUBSYSTEM CIRCUITRY.**

Functional testing of ADS components is by BIT (built-in test) functions. Refer to TM9-1270-219-13 for functional test procedures.

#### **9-567. M TROUBLESHOOTING - FIRE AND FLIGHT AIR DATA SUBSYSTEM CIRCUITRY.**

a. For subsystem troubleshooting, refer to TM 55-1520-236-T.

b. **ADS.** Troubleshooting of ADS is accomplished by BIT (built-in-test) functions. Refer to TM 9-1270-219-13 for troubleshooting procedures.

**9-568. M COLLECTIVE POSITION TRANSDUCER.**

**9-569. M DESCRIPTION - COLLECTIVE POSITION TRANSDUCER.**

The collective position transducer located in the tower transmission compartment furnishes collective position data to the fire control computer. The transducer is powered from the IFCU. Refer to paragraph 11-1 for maintenance and rigging procedures. (Refer to fire control system wiring diagrams and equipment location charts in Appendix F, paragraph F-9).

**9-570. M AIRBORNE AIRBORNE LASER TRACKER (ALT) CIRCUITRY.**

**9-571. M DESCRIPTION DESCRIPTION - AIRBORNE LASER TRACKER (ALT) CIRCUITRY.**

The ALT consists of an ALT receiver, ALT electronics unit, and ALT control panel. The ALT searches for, locks onto, and tracks pulse coded laser reflected energy from targets designated by a ground or airborne scout using a laser designator. Target output data from the ALT cues the telescope sight unit (TSU) to the target.

**9-572. M TROUBLESHOOTING TROUBLESHOOTING - AIRBORNE LASER TRACKER (ALT) CIRCUITRY.**

For troubleshooting procedures, refer to TM 55-1520-236-T.

**9-573. ~ AIM-1/EXL LASER GUNSIGHT SUBSYSTEM CIRCUITRY.**

**9-574. M DESCRIPTION DESCRIPTION - AIM-1/EXL LASER GUNSIGHT SUBSYSTEM CIRCUITRY.**

The AIF-1/EXL aiming light is mounted on the gun saddle of the universal turret. It enables low-light/night target acquisition for the turret gun by using a boresighted infrared laser beam that can only be viewed with night vision goggles (NVGs). The AIM-1/EXL subsystem can be used in conjunction with the Helmet Sight Subsystem (HSS) when NVGs are worn. The AIM-1/EXL aiming light can operate in continuous mode or activated when ACTION switch on pilot cyclic control is pressed. Subsystem operations are controlled by the switch/

relay assembly located on the outboard side of pilot's ash receiver. When switch is in NORM position the ACTION switch governs the laser emission. When switch is in CONT position the laser emissions are continuous. 28 vdc power is supplied to the AIM-1/EXL laser gunsight subsystem through the TURRET DRIVE MOTOR circuit breaker 19CB7 located on the pilot armament circuit breaker panel.

**9-575. M FUNCTIONAL TEST - AIM-1/EXL LASER GUNSIGHT SUBSYSTEM CIRCUITRY.**

The AIM-1/EXL Laser is very dangerous. Looking at the laser beam or its reflection from a shiny surface can cause permanent blindness. Ensure that the laser protective cover is kept over the emitter and that the AIM power switch is off prior to testing. The laser shall be used only in controlled areas. Night vision goggles shall be used with this test.

- a. Open all circuit breakers and place all switches to their OFF or de-energized positions.
- b. Remove aiming light protective cover/warning flag.
- c. Close TURRET DRIVE MOTOR circuit breaker.



- Do not drive turret to stops during this check.
- d. Place AIM switch to CONT position. Continuous IR laser emission tracks with the turret gun.
- e. Place AIM switch in NORM position. Press cyclic ACTION switch.
- f. Place AIM switch in OFF position.
- g. Open TURRET DRIVE MOTOR circuit breaker.
- h. Install aiming light protective cover/warning flag.

**9-576. M TROUBLESHOOTING - AIM-1/EXL LASER GUNSIGHT SUBSYSTEM CIRCUITRY.**

For troubleshooting procedures, refer to TM 55-1520-236-T.

## CHAPTER 10 FUEL SYSTEMS

### SECTION I. FUEL SYSTEMS

#### 10-1. FUEL SYSTEM.

#### 10-2. DESCRIPTION - FUEL SYSTEM.

a. The fuel system is of the crashworthy type, designed to resist fuel spillage and reduce fire hazards in the event of crash impact. All fuel cells, the interconnect lines between cells, and fuel supply lines are self-sealing. Breakaway fittings are designed to break between self-closing valves if a crash impact occurs. Fuel is contained in two crashworthy, interconnected fuel cells installed in fuselage compartments forward and aft of the transmission (figures 10-1 and 10-2). A check valve is installed between the fuel cells to restrict fuel from the aft cell flowing to the forward cell during a nose down condition. Sump drains are provided under each cell. The sump drain valve on the aft cell may be used for system defueling. Each fuel cell has a transmitter probe for fuel quantity indications. Afloat switch is installed in each cell to illuminate the FUEL LOW caution lights when the fuel supply drops to 26

gallons or below. Both cells are vented by a single overboard vent line. **M** A closed circuit refueling receiver located above and forward of the right wing allows for pressure or gravity refueling of the entire system. **P E** A cap and adapter assembly located above and forward of the right wing allows for gravity refueling of the entire system.

b. An electrically operated boost pump in each fuel cell delivers fuel to a fuel manifold. Two fuel pressure switches are installed to illuminate the FWD FUEL BOOST or AFT FUEL BOOST lights, when boost pump pressure drops below rated pressure. Fuel from the manifold passes through an electrically operated fuel shut-off valve to a fuel filter. Fuel is then routed to the engine. Thermal relief valves allow fuel to return from the engine to the fuel cells after engine shutdown.

#### 10-3. TROUBLESHOOTING - FUEL SYSTEM.



After aircraft has been defueled, a small amount of fuel may be present in the cells. Care should be taken to catch remaining fuel in a suitable container when removing fuel cell components.

#### NOTE

Perform all normal operational checks prior to using table 10-1. If a malfunction is detected that is not listed in the table, notify the next higher maintenance level.

Perform troubleshooting of the fuel system in accordance with table 10-1.

Table 10-1. Troubleshooting Fuel System

---

MALFUNCTION

TEST OR INSPECTION

**CORRECTIVE ACTION**

1. FUEL FILTER lamp illuminated.

STEP 1. Remove filter element and check for clogged filter.

**Replace filter element if dirty or clogged (paragraphs 10-7 and 10-11).**

2. AFT or FWD FUEL BOOST caution lamps illuminated.

STEP 1. Check for sound of pump running.

**If pump is running but there is no indication of fuel flow to engine, pump has failed or lines are loose or clogged. Check manifold and shutoff valves for malfunction if lights are off without flow to engine. Replace pump (paragraph 10-27 and 10-30).**

STEP 2. If pump is not running, check for electrical continuity (appendix F).

**If electrical continuity is not present, repair wiring. If continuity is normal, replace pump.**

3. FUEL LOW lamp illuminated.

STEP 1. Defuel helicopter and then refuel. FUEL LOW lamp should go out after approximately 26 gallons of total fuel capacity is in fuel cells.

**If lamp remains on, check low level warning switch. Replace if defective (paragraph 10-20 and 10-23).**

STEP 2. Check electrical circuit for continuity.

**If continuity is not normal, repair as required.**

---

**10-4. OPERATIONAL CHECK - FUEL SYSTEM.**

Refer to paragraphs 9-276, 9-354, and 9-358 for operational check of fuel system.

**10-5. FUEL FILTER.****10-6. DESCRIPTION - FUEL FILTER.**

The filter (10, figure 10-2) is mounted on a bracket located on left side of the engine compartment deck. The filter contains a replaceable paper-type element (45) and has an internal bypass, with electrical connection to the FUEL FILTER caution lamp to warn when the filter is about to be bypassed due to clogging. Piping connections on the filter include the inlet line, drain line, and a quick disconnect outlet coupling.

**10-7. REMOVAL - FUEL FILTER.**

- a. Open left side of engine compartment cowling.
- b. Disconnect fuel hose from outlet coupling on top of filter.
- c. Drain fuel from filter by opening drain line valve. Use a suitable tool to slightly depress self-closing valve of filter outlet coupling to admit some air and assist drainage.
- d. Open V-band trunnion clamp (47, figure 10-2) and remove bowl (43) and filter element (45) from filter head (49). Separate element (45) and packings (44, 46, and 48) from bowl. Discard filter element and packings.
- e. Disconnect electrical cable plug, remove screws (53), washers (52) and remove pressure switch (51). Remove packings (50).





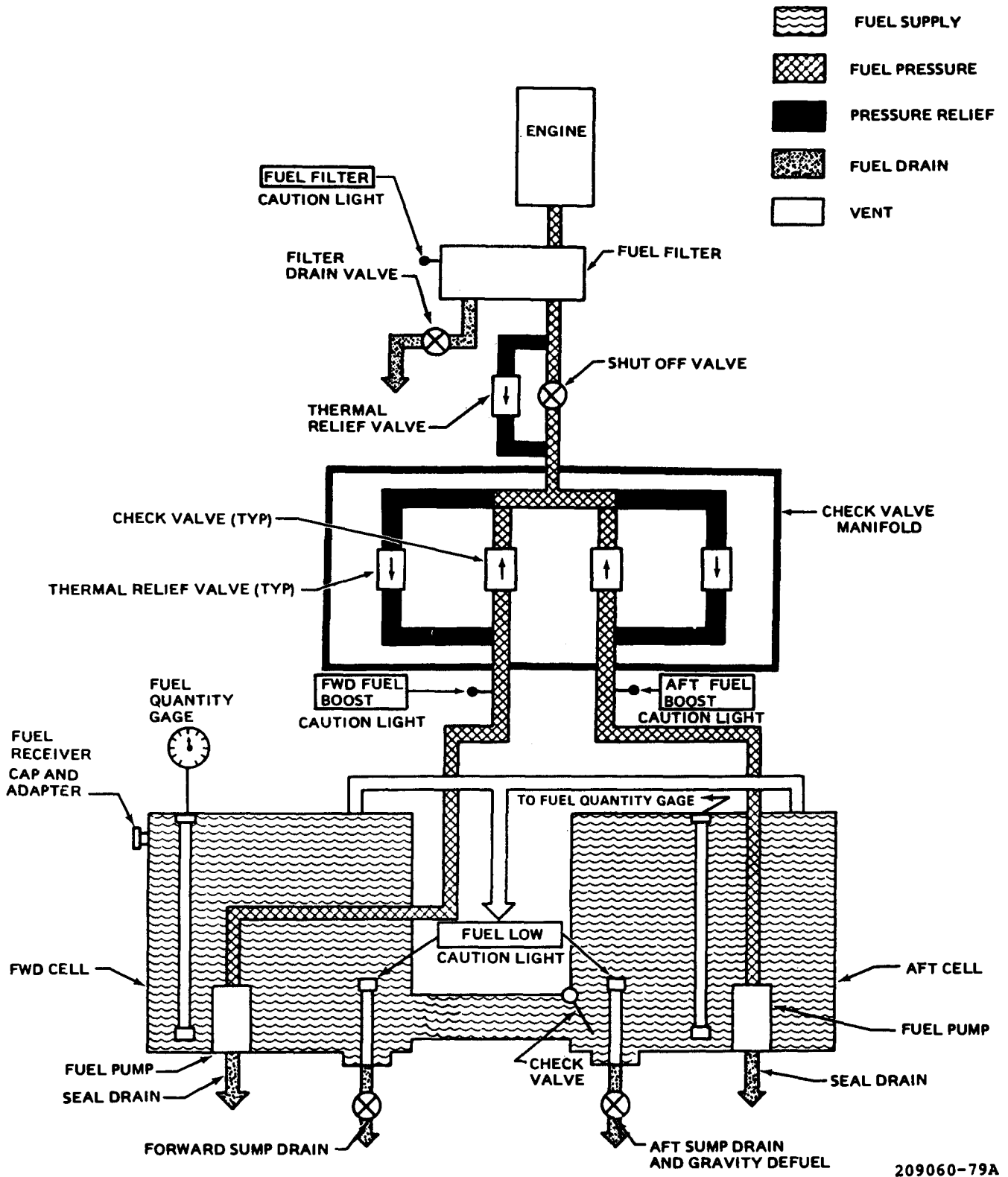

209060-79A

Figure 10-1. Fuel System Schematic

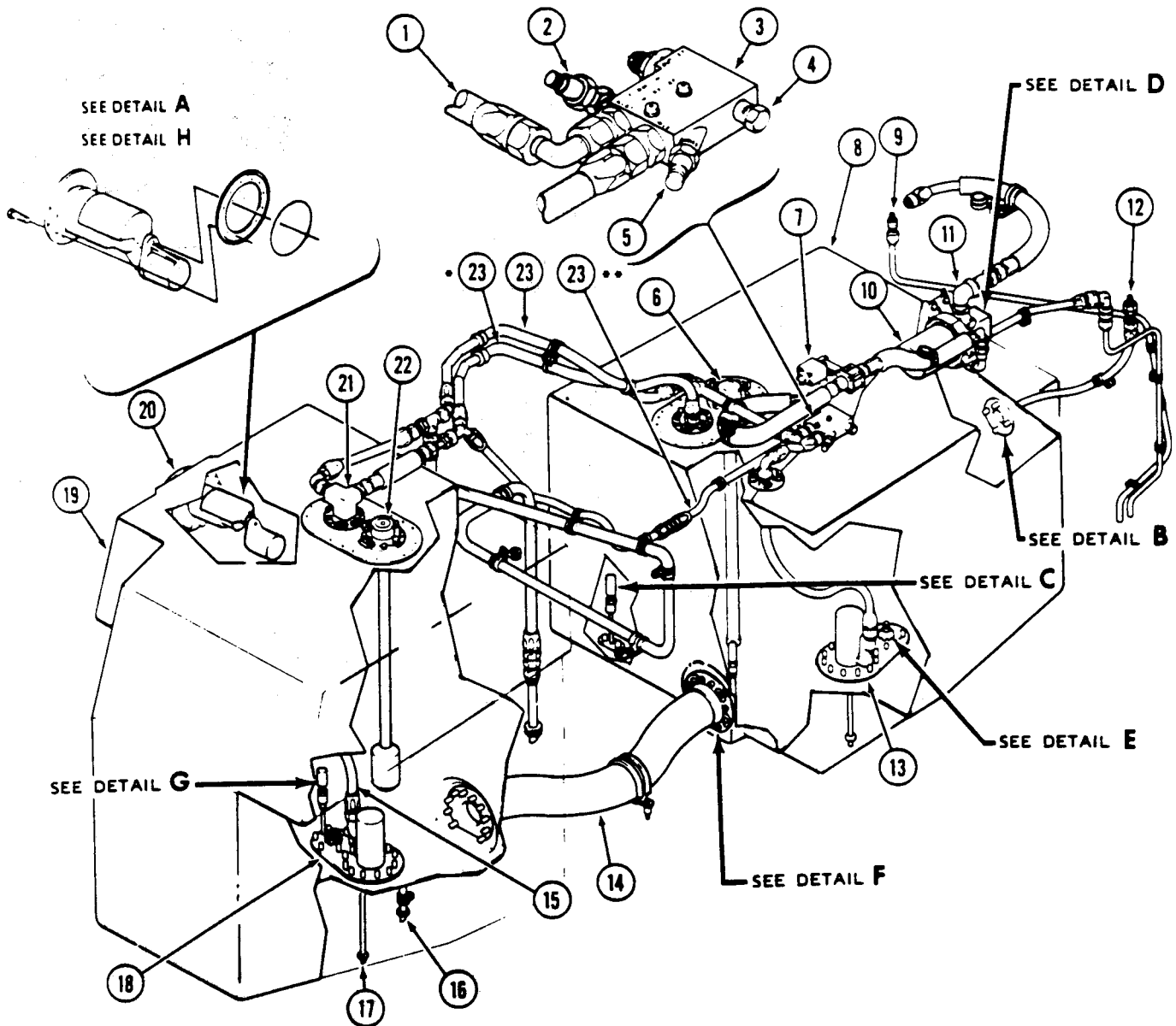

- 1. Hose assembly
- 2. Pressure switch
- 3. Check valve manifold
- 4. Plug
- 5. Pressure switch
- 6. Fuel quantity probe
- 7. Fuel shutoff valve
- 8. Aft fuel cell

- 9. Engine drain coupling
- 10. Filter
- 11. Engine fuel supply hose
- 12. Governor bleed coupling
- 13. Boost pump
- 14. Crossover hose
- 15. Fuel hose
- 16. Drain valve

- 17. Seal drain
- 18. Boost pump
- 19. Forward fuel cell
- 20. Fuel receiver
- 21. Fuel vent fitting
- 22. Fuel quantity probe
- 23. Vent lines

209060-129-1B

Figure 10-2. Fuel System (Sheet 1 of 4)

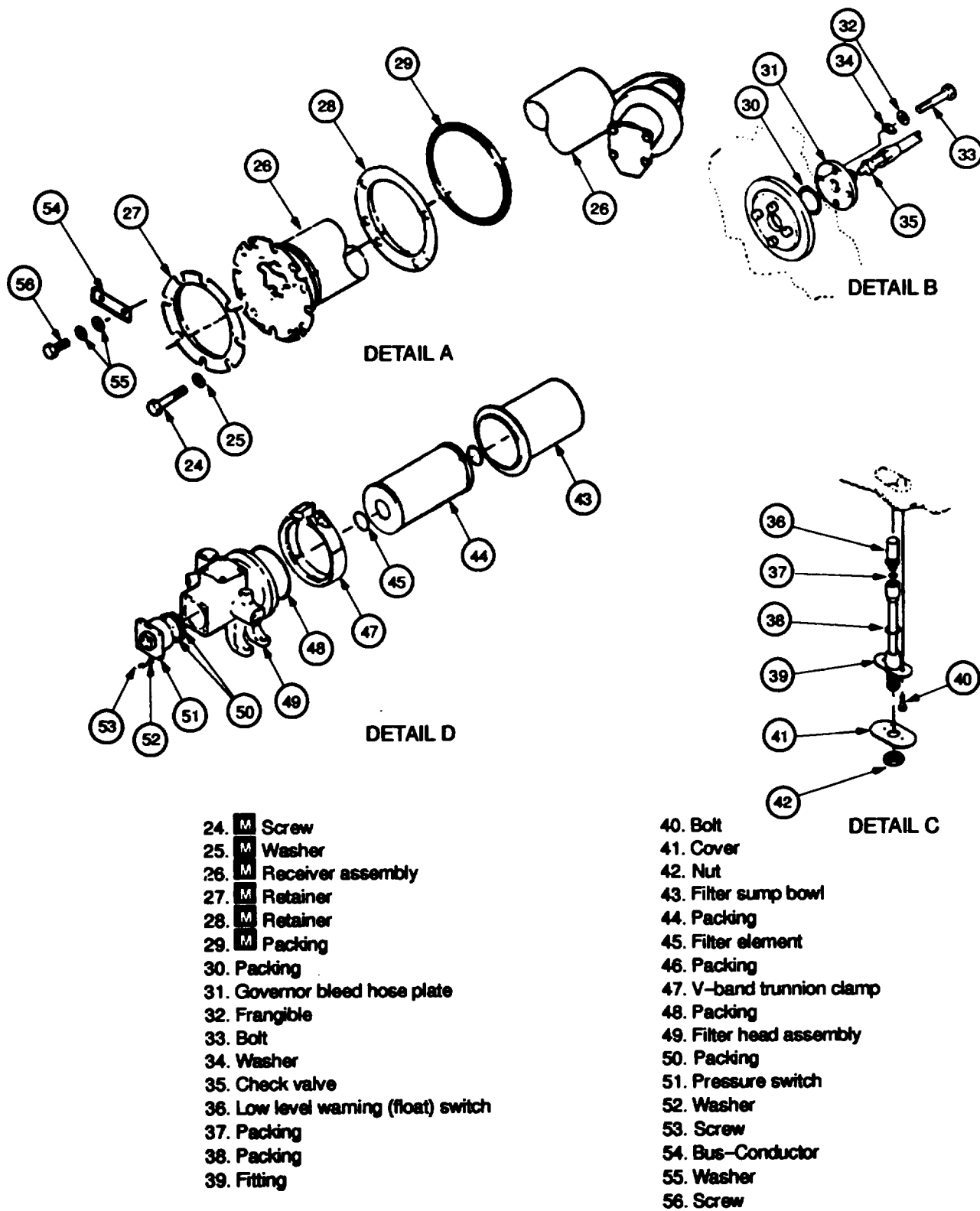
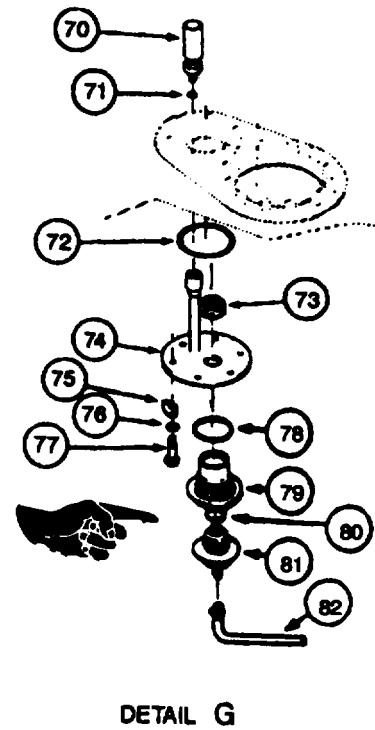
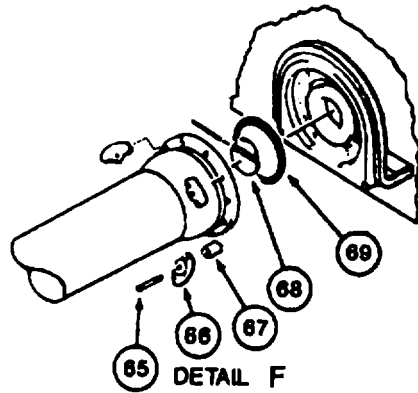
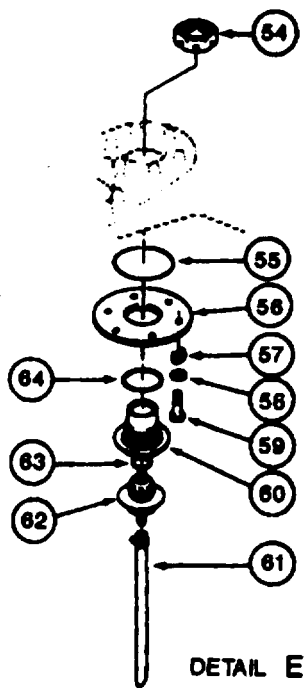

Figure 10-2. Fuel System (Sheet 2 of 4).



- 54. Nut
- 55. Packing
- 56. Plate
- 57. Frangible clip
- 58. Washer
- 59. Bolt
- 60. Defuel sump and drain valve (upper half)
- 61. Hose
- 62. Defuel sump and drain valve (lower half)
- 63. Packing
- 64. Packing
- 65. Bolt
- 66. Frangible clip
- 67. Spacer

- 68. Check (flapper) valve
- 69. Packing
- 70. Low level warning (float) switch
- 71. Packing
- 72. Packing
- 73. Nut
- 74. Fitting assembly
- 75. Frangible clip
- 76. Washer
- 77. Bolt
- 78. Packing
- 79. Sump drain valve (upper half)
- 80. Packing
- 81. Sump drain valve (lower half)
- 82. Hose

Figure 10-2. Fuel System (Sheet 3 of 4)

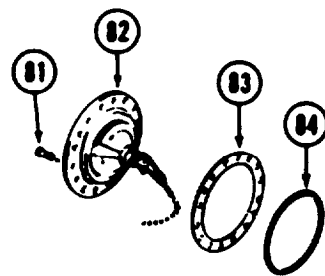

- 81. Screw
- 82. Cap and adapter assembly
- 83. Retainer
- 84. Packing

DETAIL H

209060-129-4A

Figure 10-2. Fuel System (Sheet 4 of 4)

**NOTE**

Filter head (49) will usually be left in place, but can be removed as in the following step.

f. Remove the filter head (49) by disconnecting the inlet pressure and drain lines from the filter head. Detach the head assembly from bracket by removing four bolts, nuts, and washers.

**10-8. INSPECTION – FUEL FILTER.**

a. Inspect filter element (45, figure 10-2) for contamination to determine if any corrective action is needed beyond replacement of element and packings.

b. Inspect filter head assembly (49) and bowl (43) for damage.

c. Inspect V-band trunion clamp (47) for serviceable condition.

d. Inspect pressure switch (51) for cracks, broken pins, and corrosion.

**10-9. CLEANING – FUEL FILTER BOWL.**

**WARNING**

Cleaning solvent is flammable and toxic. Provide adequate ventilation. Avoid prolonged breathing of solvent vapors and contact with skin or eyes.

a. Clean bowl (43, figure 10-2), V-band trunion clamp (47), and exposed surfaces of head assembly (49) with solvent (CI 12).

b. Remove excess solvent with clean, dry cloth.

**10-10. REPAIR OR REPLACEMENT – FUEL FILTER.**

a. Install new filter element (45, figure 10-2) and new packings (44, 46, and 48).

b. Replace packings (50) if damaged or leaking.

c. Replace pressure switch (51) if electrical connector is damaged.

d. Replace filter head assembly (49) and/or bowl (43) if damaged.

#### 10-11. INSTALLATION — FUEL FILTER.

a. If removed, position filtered head assembly (49, figure 10-2) on outboard side of mounting bracket and install four bolts, nuts, and washers. Connect drain and inlet lines to fittings.

#### NOTE

Ensure that plug is installed in pressure tap port of filter.

b. Place new packing (44) on boss in bottom of fitter bowl. Place new filter element (45) in bowl (43) and seat firmly on boss.

c. Install new packing (48) around tip of bowl (43) next to damping flange.

d. Place new packing (46) around center boss in filter head. Install bowl (43) and filter element (45) into fitter head assembly (48).

#### NOTE

Install V-band damp assembly with clamp latch on left side of the fuel filter and gap (drain) at the 6 o'clock position.

e. Install V-band trunnion damp (47) around mating flanges of fitter head and bowl. Torque nut 50 inch-pounds.

f. Connect hose from engine fuel control inlet to outlet coupling (11) on fitter head. Ensure that a minimum of 1.5 inches exists between hose and engine air diffuser. Close cowling.

g. During next ground run-up, check fuel filter and connections for leaks. Also check that FUEL FILTER caution lamp does not light.

#### 10-12. FUEL SHUTOFF VALVE.

#### 10-13. DESCRIPTION — FUEL SHUTOFF VALVE.

A motor-operated shutoff valve (4, figure 10-3) is installed in the fuel supply system between the check valve manifold and the fuel fitter. The valve is mounted on front of the engine forward firewall at left side. An internal bypass valve allows the thermal relief of fuel

trapped on outlet side of the shutoff valve. The valve is equipped with an ON-OFF lever and position indicator to allow manual operation of the valve.

#### 10-14. REMOVAL — FUEL SHUTOFF VALVE.

a. Open engine and transmission cowling door at left side.

b. Disconnect engine fuel inlet hose (10, figure 10-3) from filter outlet coupling. Open filter drain valve, and manually open fuel shutoff valve (4) to release trapped fuel. After short period of drainage, close both valves.

c. Perform function check of fuel shut-off valve (4) prior to removal to determine whether valve motor will open and close fuel valve.

d. Disconnect electrical connector (3) from shutoff valve (4).

e. Disconnect fuel inlet hose (1) and fuel outlet hose (8) from valve (4). Cap open ends of hoses.

f. Remove four nuts (7), washers (6), and screws (2). Remove shutoff valve inlet and outlet connectors (5 and 9).

g. Do not remove packing installed in fuel shutoff valve (4) ports where connectors (5 and 9) were removed.

#### 10-15. INSPECTION — FUEL SHUTOFF VALVE.

a. Inspect valve for external damage and leakage.

b. Inspect connectors for damaged threads or mating surfaces.

c. Inspect electrical connector for broken or bent pins.

d. Inspect packings at fuel valve inlet and outlet for damage. Replace fuel shutoff valve if either packing is damaged or missing.

#### 10-16. REPAIR OR REPLACEMENT — FUEL SHUTOFF VALVE.

a. Replace fuel shutoff valve if motor will not open and close the valve.

b. Replace fuel shutoff valve if inspection requirements are not met.

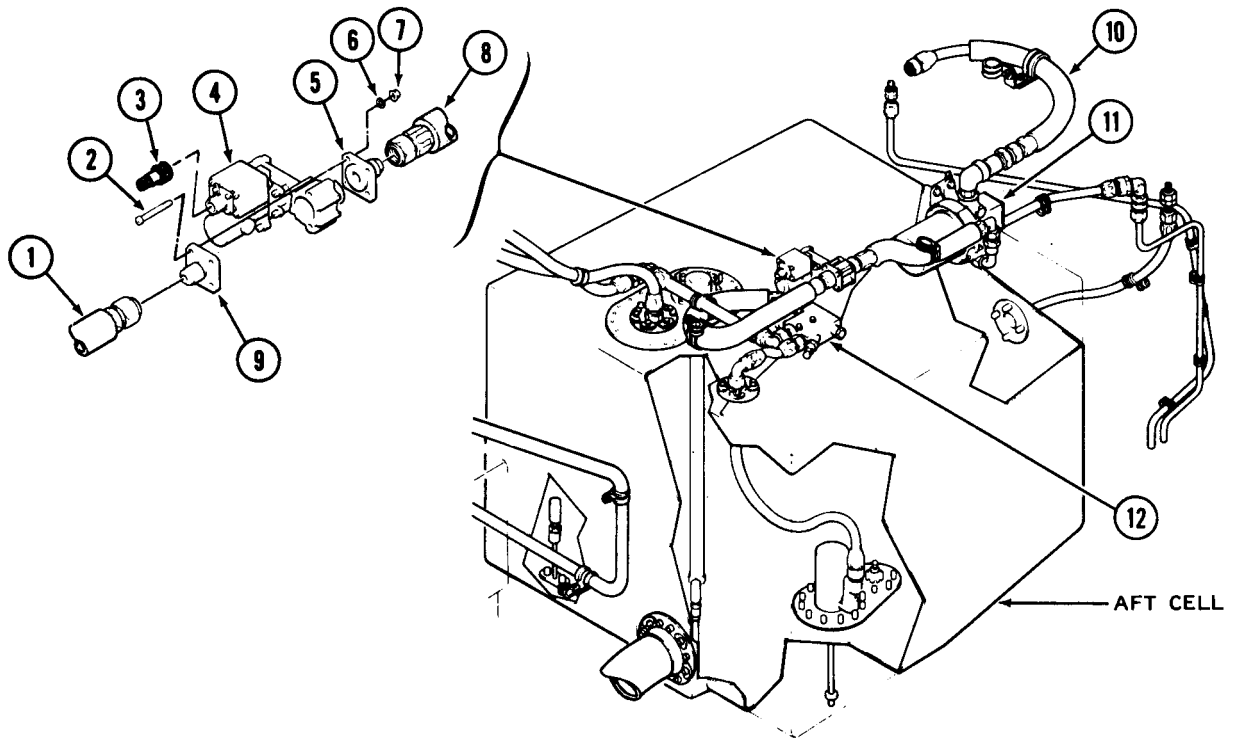

209060-82

- |                                |                            |                                   |
|--------------------------------|----------------------------|-----------------------------------|
| <b>1. Fuel inlet hose</b>      | <b>5. Connector</b>        | <b>9. Connector</b>               |
| <b>2. Screw (4)</b>            | <b>6. Washer</b>           | <b>10. Engine fuel inlet hose</b> |
| <b>3. Electrical connector</b> | <b>7. Nut</b>              | <b>11. Fuel filter</b>            |
| <b>4. Fuel shutoff valve</b>   | <b>8. Fuel outlet hose</b> | <b>12. Check valve manifold</b>   |

**Figure 10-3. Fuel Shutoff Valve**

**10-17. INSTALLATION - FUEL SHUTOFF VALVE.**

a. Install connector (5, figure 10-3) and connector (9) as follows:

(1) Inspect open ports in fuel shutoff valve (4), where connectors (5 and 9) will be installed, for presence of serviceable packings (not illustrated). If either packing is unserviceable or missing, install new packing.

(2) Identify connector (5) by threads that match fuel outlet hose (8). Identify connector (9) by threads that match fuel inlet hose (1). Position connectors (5 and 9) on fuel shutoff valve (4) and install four screws (2), washers (6), and nuts (7), Torque nuts evenly.

b. Position shutoff valve (4) on front of engine forward firewall, at left side just below induction

baffle. Install four mounting screws (2), nuts (7), and washers (6).

c. Connect fuel inlet hose (1) from check valve manifold (12) to inlet connector (9).

d. Connect fuel outlet hose (8) from fuel filter (11) to valve outlet connector (5).

e. Connect electrical connector (3) to receptacle on valve motor. Lockwire connector.

f. Reconnect engine fuel inlet hose (10) to outlet coupling of fuel filter. Close cowling.

g. At next ground run-up, check shutoff valve for proper operation and for leaks.

### 10-18. LOW LEVEL WARNING (FLOAT) SWITCHES.

### 10-19. DESCRIPTION - LOW LEVEL WARNING (FLOAT) SWITCHES.

There are two low level warning (float) switches (36 and 70, figure 10-2) installed, one in the aft fuel cell and one in the forward fuel cell. The switches will cause the FUEL LOW lamps to light when approximately 26 gallons of fuel remain in fuel cells.

### 10-20. REMOVAL - LOW LEVEL WARNING (FLOAT SWITCHES).

- a. Defuel helicopter (paragraph 1-3),
  - b. Perform functional test of low level warning float switches to confirm that FUEL LOW worded segment in caution panel illuminates when battery switch is positioned to **P** ON, **E** M START.
  - c. Remove screw-mounted panel from underside of fuselage below forward and/or aft fuel cell.
  - d. Disconnect electrical leads at terminal board. Refer to Appendix F.
  - e. Remove low level warning (float) switch (36, figure 10-2) from aft fuel cell.
    - (1) Remove nut (42) and cover (41).
    - (2) Remove bolts (40).
    - (3) Withdraw fitting (39) from fuel cell.
    - (4) Remove switch (36) from fitting (39)
    - (5) Remove packings (37 and 38).
  - f. Remove low level warning (float) switch (70, figure 10-2) from forward fuel cell,
    - (1) Loosen clamp and remove hose (80).
    - (2) Remove bolts (77), washers (76), and frangible clips (75).
    - (3) Withdraw fitting assembly (74) from fuel cell.
    - (4) Remove switch (70) from fitting assembly (74).

- (5) Remove packings (71 and 72).

### 10-21. INSPECTION - LOW LEVEL WARNING (FLOAT) SWITCHES.

- a. Inspect threads for damage.
- b. Inspect electrical lead for frayed or damaged insulation.
- c. Inspect sensing holes at top and bottom of switch for obstructions.

### 10-22. REPAIR OR REPLACEMENT - LOW LEVEL WARNING (FLOAT) SWITCHES.

- a. Replace low level warning switches that were found to be inoperative in functional check in paragraph 10-20.b.
- b. Replace low level warning switches that failed to meet inspection requirements (paragraph 10-21).

### 10-23. INSTALLATION - LOW LEVEL WARNING (FLOAT) SWITCHES.

- a. Install low level warning (float) switch (70 figure 10-2) in forward fuel cell.
  - (1) Install packing (71) on switch (70) and insert electrical leads down through fitting assembly (74). Screw switch tightly onto fitting assembly.
  - (2) Install packings (71 and 72) and install fitting assembly (74) using frangible clips (75), washers (76), and bolts (77).
  - (3) Connect electrical leads to terminal board (Appendix F).
- b. Install low level warning (float) switch (36) in aft fuel cell.
  - (1) Install packing (37) on switch (36) and insert electrical leads down through fitting (39). Screw switch tightly onto fitting.
  - (2) Install packing (38) and install fitting (39) using bolts (40). Install-cover (41) and nut (42)
  - (3) Connect electrical leads to terminal board (Appendix F).



**10-24. TEST PROCEDURES — LOW LEVEL WARNING (FLOAT) SWITCHES (AVIM).**

Refer to paragraph 9-276 (13) for test procedures.

**10-25. FUEL BOOST PUMPS.**

**10-26. DESCRIPTION — FUEL BOOST PUMPS.**

An electric motor-driven fuel boost pump (4, figure 10-4) is mounted into the bottom of each fuel cell, to deliver fuel at a rate up to 990 pounds per hour at 5 to 30 psi pressure. Each pump is submerged in fuel, with its outlet connected to a hose leading to an external fuel line. Electrical leads and a seal drain line are provided on the lower exterior face of the pump.

**10-27. REMOVAL — FUEL BOOST PUMPS.**

**NOTE**

Removal of boost pump from forward or aft fuel cell is the same except for location and access.

- a. Drain both fuel cells (paragraph 1-3).
- b. Remove screw-mounted panel from underside of fuselage below forward and/or aft fuel cell.
- c. Disconnect boost pump electrical leads from terminal board (Appendix F).
- d. Remove seal drain tube (12, figure 10-4) from union (11) on pump (4).
- e. Remove bolts (9), washers (8), and frangible clips (7) from mounting flange of pump.
- f. Lower pump assembly enough for access to hose connection (1) on pump discharge fitting (2). Disconnect hose and remove pump and gasket (3). Cover open port.

**10-27.1. REMOVAL - FUEL BOOST PUMP CARTRIDGE (CRASHWORTHY).**

- a. Disconnect electrical wiring from fuel pump cartridge (2, figure 10-4.1)

**WARNING**

A bent inlet shut-off valve arm may prevent the shut-off valve from completely opening causing a restricted fuel flow. Apply pressure directly over valve spring when opening or closing valve stem assembly. Trying to compress valve spring from free end of valve arm will cause valve arm to bend. When removing or installing shoulder screw, keep valve arm depressed.

- b. Remove lockwire and screw (5). Turn arm (4) to 180° counterclockwise position.

**NOTE**

This arm shuts off fuel to the pumping cavity. Upon removal of the cartridge, approximately one pint of fuel will be lost.

- c. Remove fuel pump drain plug (3) and drain residual fuel from fuel pump into suitable container.
- d. Remove lockring (6) securing fuel pump cartridge (2) to fuel pump housing (1).
- e. Remove fuel pump cartridge (2) from fuel pump housing (1) using cartridge removal tool (figure 10-2.2). Discard packings (7).
- f. Clean cartridge cavity and lockring of all foreign matter.

**10-28. INSPECTION — FUEL BOOST PUMPS.**

- a. Inspect connectors and fittings for cracks and damaged threads.
- b. Inspect electrical leads for frayed or damaged insulation.

**10-29. REPAIR OR REPLACEMENT — FUEL BOOST PUMPS. (AVIM)**

- a. Replace gasket if leaking or damaged.
- b. Replace pump having damaged connectors or electrical leads.
- c. if pump is replaced, remove all fittings from old pump for installation on new pump.

**10-29.1 REPAIR OF FUEL BOOST PUMP CARTRIDGE (CRASHWORTHY).**

Refer to TM 55-2915-335-30&P.

**10-30. INSTALLATION – FUEL BOOST PUMPS.**

**NOTE**

Installation of boost pump in forward or aft fuel cell is the same except for location and access.

- a. Place gasket (3, figure 10-4) on mounting flange of pump (4). Uncover mounting port of fuel cell. insert pump partially into port and connect fuel hose (1) to outlet fitting (2).

b. Install frangible dips (7) at 7 and 10 o'clock positions for forward cell, and at 5 and 8 o'clock positions for aft cell. Look up with reference to most aft pump bolts as 12 o'clock position. Install bolts (9) and washers (8). Torque bits 50 TO 70 inch-pounds.

c. Connect seal drain tube (12) to union (11) on pump.

d Connect electrical leads from pump to terminal board. See circuit wiring diagram (Appendix F).

e. Service fuel cell and check for leaks (paragraph 1-3).

### 10-30.1 . INSTALLATION — FUEL BOOST PUMP CARTRIDGE (CRASHWORTHY).

#### NOTE

Do not use removal tool to Install cartridge.

Visually inspect that fuel bleed valve is installed on top of fuel pump housing (1, figure 104.1) on cartridge type pumps.

#### WARNING

If fuel bleed valve is not installed, engine surging/flameout will occur when the fuel level is below the top of the fuel boost pump housing and the boost pump is off or inoperative

b. Lightly lubricate packings (7, figure 104.1) using grease (C59). Install packings (7) on new cartridge (2). insert fuel boost pump cartridge (2) into fuel pump housing (1) ensuring arrows on fuel pump and fuel pump housing align.

c. Install locking (6) securing fuel pump cartridge (2) to fuel pump housing (1).

d install fuel pump drain plug (3) into fuel pump. Connect positive electrical lead with the short straight slot screw (8).

#### WARNING

A bent inlet shut-off valve arm may prevent the shut-off valve from completely opening causing a restricted fuel flow. Apply pressure directly over valve spring when opening or closing valve stem assembly. Trying to compress valve spring from free end of valve arm will cause valve arm to bend When removing or installing shoulder screw, keep valve arm depressed.

e. Turn fuel shut-off arm (4) clockwise into position, aligning arm and screw hole. Press shaft end of arm up, measure gap between arm and base of fuel pump cartridge. Fill gap with flat washers (part number AN960PD416/AN960PD416L) to eliminate any possibility of bending arm. Install electrical lead under shoulder of screw and lockwire (C151).

f. Turn on master switch and fuel pump and check for proper fuel pressure.

### 10-31. TEST PROCEDURES – FUEL BOOST PUMPS.

Refer to paragraph 9-358 for operational check of fuel boost pumps.

### 10-32. FUEL QUANTITY TRANSMITTERS.

Refer to paragraph 8-221.

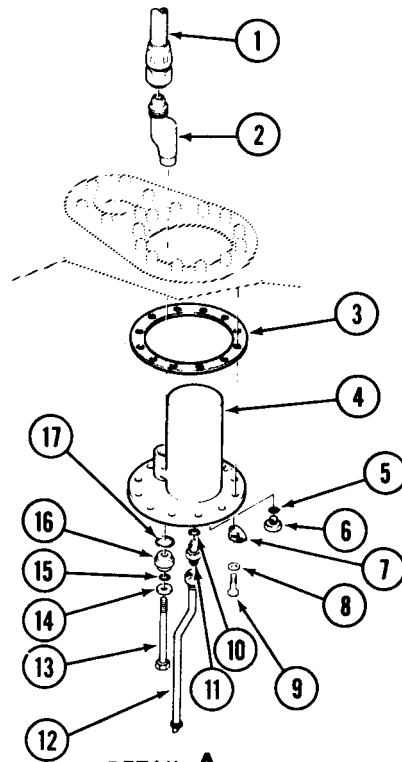
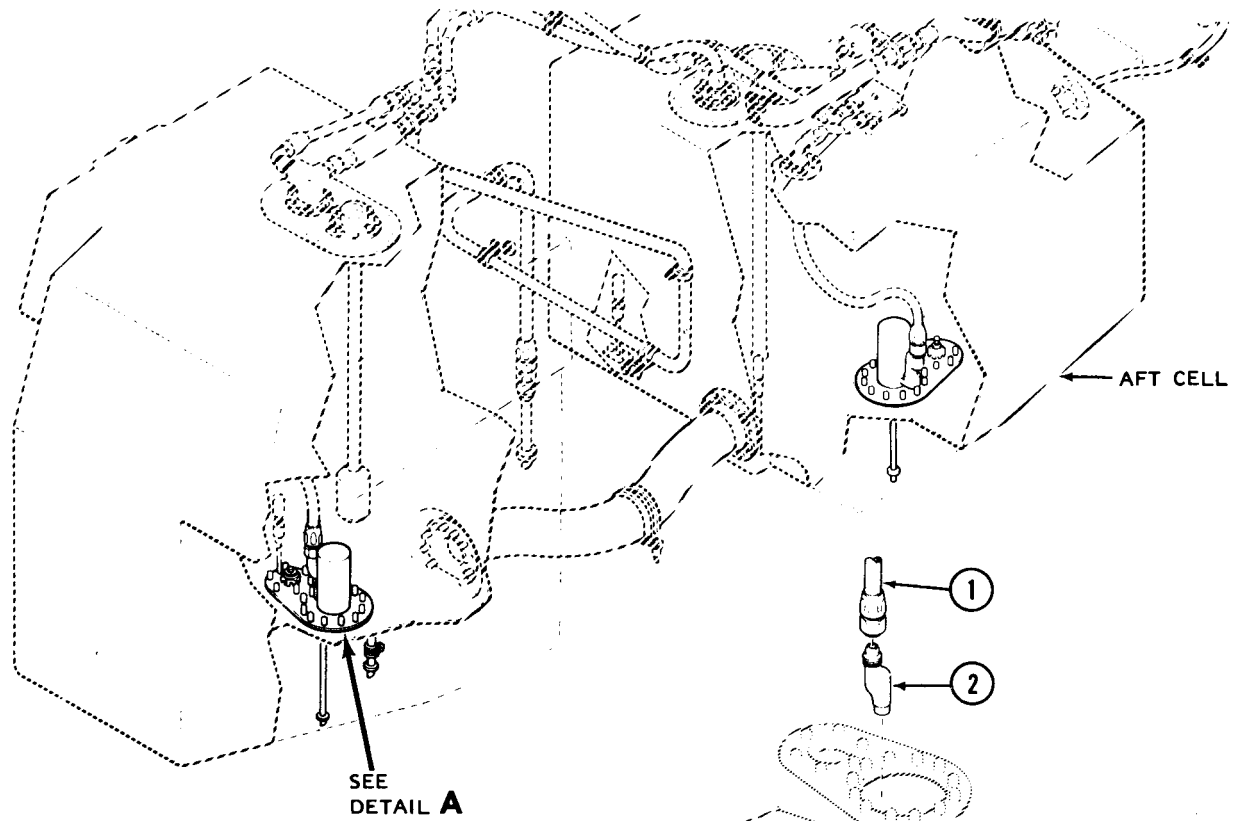

**DETAIL A**  
TYPICAL AFT CELL

- 1. Fuel hose
- 2. Fitting
- 3. Gasket
- 4. Fuel boost pump
- 5. Packing
- 6. Plug
- 7. Clip
- 8. Washer
- 9. Bolt
- 10. Packing

- 11. Union
- 12. Seal drain tube
- 13. Bolt
- 14. Washer
- 15. Packing
- 16. Plug
- 17. Packing

209060-83A

Figure 10-4. Fuel Boost Pump

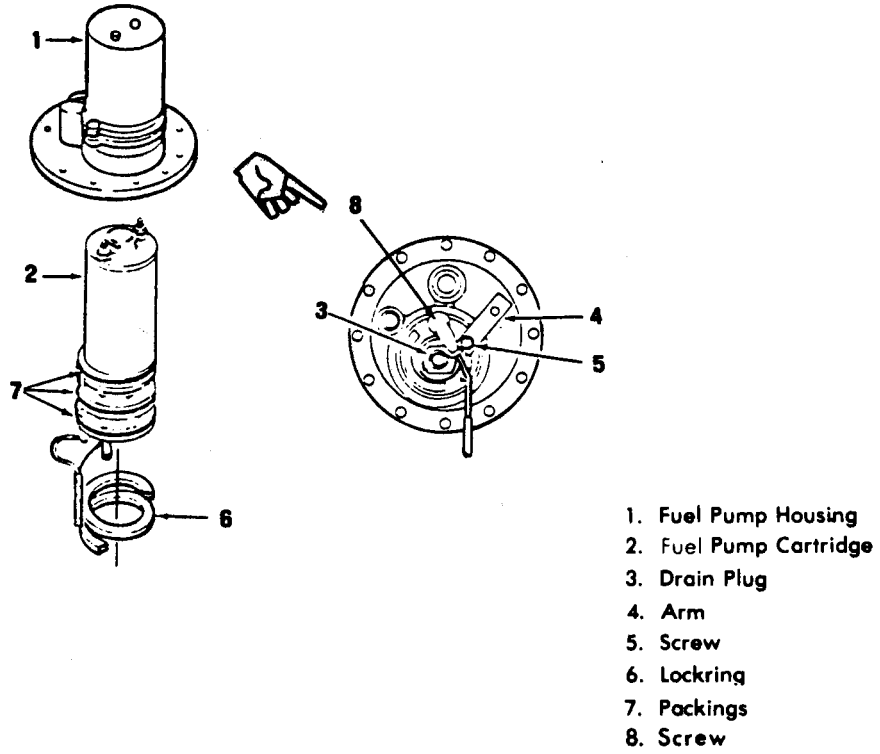
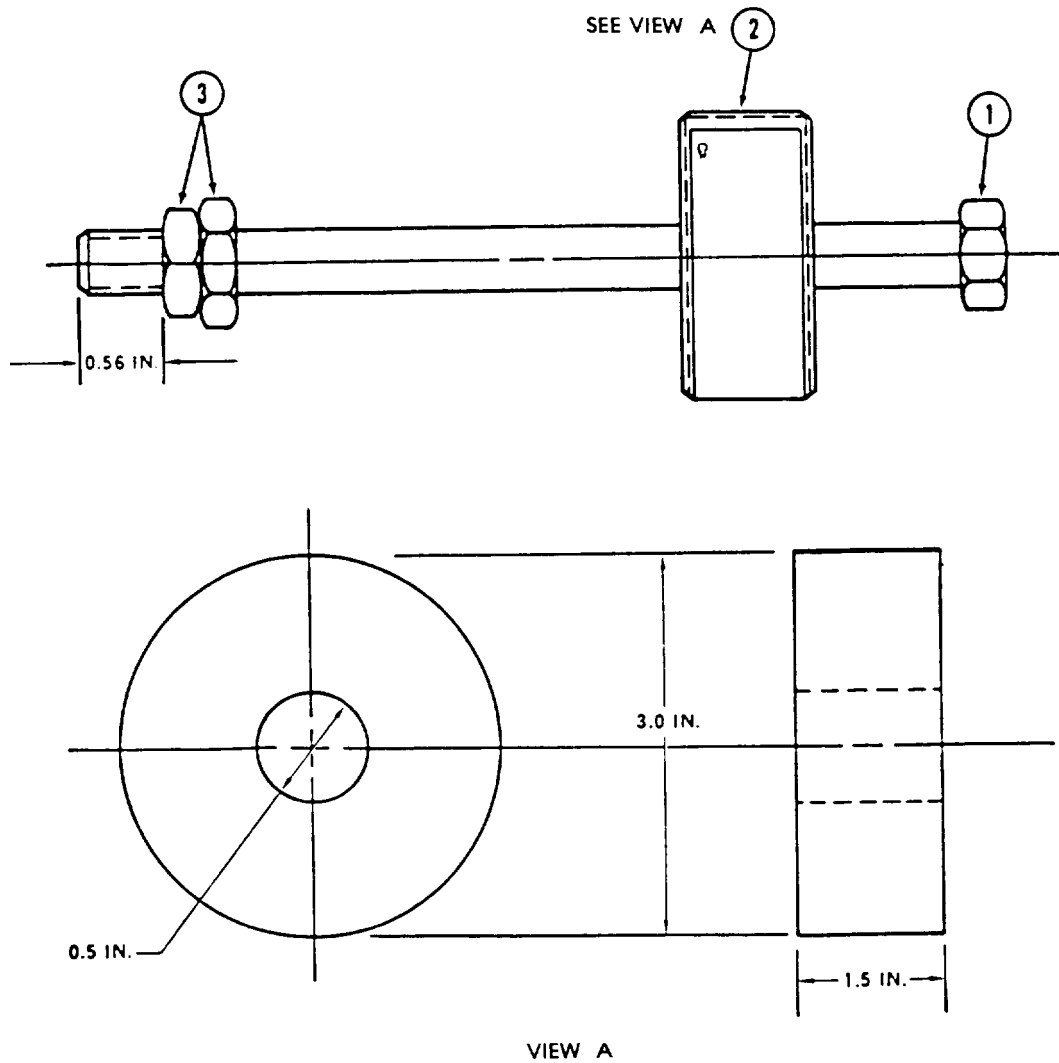

Figure 10-4.1. Fuel Boost Pump Cartridge



- 1. Bolt - 7/16-20 Hex Hd. x 6 in. long
- 2. Sliding weight - 7075 Aluminum Alloy
- 3. Nut - 7/16-20 Hex (2 ea)

Figure 10-4.2. Work Aid for Fuel Pump Cartridge Removal



**10-33. CHECK VALVE MANIFOLD.****10-34. DESCRIPTION — CHECK VALVE MANIFOLD.**

A valve manifold (3, figure 10-2), located just ahead of engine forward firewall at left side, is connected into fuel pressure lines ahead of the shutoff valve. The manifold contains two separate check valve elements which prevent reverse flow, except through bypasses which will relieve thermal expansion of trapped fuel. One outlet port of the manifold is used, another is plugged. Two pressure switches are installed in the inlet side of the manifold, to cause lighting of FWD FUEL BOOST or AFT FUEL BOOST caution panel segments if either fuel boost pump fails to deliver normal pressure.

**10-35. REMOVAL — CHECK VALVE MANIFOLD.**

- a. Open transmission cowling door at left side.
- b. Disconnect electrical connectors from both pressure switches on check valve manifold.
- c. Provide a small container to catch trapped fuel. Disconnect fuel lines from fittings at manifold inlets and outlet. Cap open ends of lines.
- d. Remove two screws, washers, and spacers from manifold (3).

**10-36. INSPECTION — CHECK VALVE MANIFOLD.**

- a. Inspect manifold for cracks and fittings for damaged threads.
- b. Inspect pressure switches for cracks and bent or broken pins.

**10-37. REPAIR OR REPLACEMENT — CHECK VALVE MANIFOLD.**

- a. Replace pressure switches having cracks or loose and broken pins.
- b. Replace gaskets and elbow or plug at manifold outlet if leaking or damaged.
- c. Replace manifold assembly if damaged or malfunction occurs. Transfer outlet fittings and pressure switches to replacement assembly as required.

**10-38. INSTALLATION — CHECK VALVE MANIFOLD.**

- a. Check that fittings and pressure switches are properly installed, with gaskets, in manifold assembly (figure 10-2).
- b. Hold manifold with flow arrows pointing aft, and outlet elbow at aft inboard side. Insert two screws, with washers under heads, downward through manifold. Place a spacer on lower end of each screw.
- c. Align manifold assembly to mounting holes in deck, and tighten screws securely.
- d. Connect fuel line from shutoff valve inlet arrow of manifold. Connect fuel pressure line and hose to manifold inlet fittings.
- e. Connect electrical connectors to pressure switches.
- f. Check for proper operation and for leaks.

**10-39. CLOSED CIRCUIT REFUELING RECEIVER.****10-40. DESCRIPTION — CLOSED CIRCUIT REFUELING RECEIVER.**

The closed circuit refueling receiver is located on the fuselage above and forward of the right wing. The receiver accepts either a closed circuit refueling nozzle or a gravity fill nozzle. The receiver is capable of accepting fuel at the rate of 100 gallons per minute (GPM). The receiver automatically shuts off when system is full, system internal pressure exceeds 2.5 PSI, or flow rate exceeds 130 GPM.

**10-41. REMOVAL — CLOSED CIRCUIT REFUELING RECEIVER.**

- a. Defuel as required.
- b. Remove screws (24, figure 10-2), washers (25), and bus-conductor (54).
- c. Remove retainer (27), receiver assembly (26), gasket (28), and packing (29).

**10-42. INSPECTION — CLOSED CIRCUIT REFUELING RECEIVER.**

Inspect for damage, freedom of operation and corrosion.

**10-43. REPAIR OR REPLACEMENT — CLOSED CIRCUIT REFUELING RECEIVER.**

Replace if defects in paragraph 10-42 are noted.

**10-44. INSTALLATION — RECEIVER ASSEMBLY.**

a. Position packing (29, figure 10-2), gasket, and receiver assembly (26) in opening in aircraft. Position retainer (27) on outboard face of receiver assembly.

b. Install screws (24), washers (25), and bus-conductor (54). Position bus-conductor at ten o'clock position, under screw head. Torque bolts evenly 50 TO 70 inch-pounds.

Paragraphs 10-45 through 10-50 have been deleted.

**10-51. DEFUEL AND SUMP DRAIN VALVE.**

**10-52. DESCRIPTION — DEFUEL AND SUMP DRAIN VALVE.**

A defuel and sump drain valve (60 and 62, figure 10-2) is installed on the bottom of the helicopter beneath the aft fuel cell. The valve is a two-piece valve which will automatically close the valve opening when the lower valve is removed for defueling and draining. A special fitting is required to open the upper valve for defueling and draining operations. The valve will drain fuel from both the forward and aft fuel cells.

**10-53. REMOVAL — AFT DEFUEL AND SUMP DRAIN VALVE.**

a. Defuel forward and aft fuel cells (paragraph 1-3).

b. Remove access cover beneath aft fuel cell.

c. Disconnect clamp and remove hose (61, figure 10-2).

d. Deleted.

e. Remove bolts (59), washers (58), frangible clips (57), and plate (56) with upper and lower halves of valve assemblies (60, 62) attached and remove packing (55).

f. Remove nut (54) and upper half of valve (60) from plate (56) and remove packing (64).

g. Remove lower half of valve (62) from upper half of valve (60) and remove packing (63).

**10-54. INSPECTION — AFT DEFUEL AND SUMP DRAIN VALVE.**

a. Inspect valve for cracks and damaged threads.

b. Inspect shutoff function of upper valve for damage that would allow leakage.

**10-55. REPAIR OR REPLACEMENT — AFT DEFUEL AND SUMP DRAIN VALVE.**

a. Replace valve having cracks and/or damaged threads.

b. Replace valve having faulty shutoff operation (if applicable) (C-137).

**10-56. INSTALLATION — AFT DEFUEL AND SUMP DRAIN VALVE.**

a. Place packing (64, figure 10-2) on upper valve (60), insert in plate (56), and install nut (54).

b. Install packing (63) and lower half of valve (62) on upper half of valve (60).

c. Place packing (55) in position and install plate (56) using frangible clips (57) at 5 and 8 o'clock positions, washer (58) and bolts (59). Torque bolts 50 TO 70 inch-pounds.

d. Connect hose (61) to lower valve.

**NOTE**

Aircraft only needs to be refueled to a level high enough to check sump drain valve for leakage.

e. Refuel aircraft (paragraph 1-3).

f. Inspect drain valve for leakage. If no leakage occurs, continue to refuel aircraft. If there is any evidence of leakage, recheck torque of bolts (59). If leakage is still present, repeat steps in paragraphs 10-53 through 10-56.

g. Install access cover.



**10-57. FORWARD SUMP DRAIN VALVE.****10-58. DESCRIPTION — FORWARD SUMP DRAIN VALVE.**

The sump drain valve (79, figure 10-2) is located beneath the forward fuel cell. The valve provides a means of draining residual fuel from the forward fuel cell.

**10-59. REMOVAL — FORWARD SUMP DRAIN VALVE.**

a. Defuel forward and aft fuel cells (paragraph 1-3).

b. Remove access cover beneath forward fuel cell.

c. Disconnect clamp and remove hose (82, figure 10-2).

d. Remove bolts (77), washers (76), frangible dips (75), and fitting assembly (74) with upper and lower halves of valves assemblies (78, 81) attached and remove packing (72).

e. Remove nut (73) and upper half of valve (79) from fitting assembly (74) and remove packing (78).

f. Remove lower half of valve (81) from upper half of valve (78) and remove packing (80).

**10-60. INSPECTION — FORWARD SUMP DRAIN VALVE.**

a. Inspect valve for cracks and damaged threads.

b. Inspect valve for correct operation of shutoff function.

**10-61. REPAIR OR REPLACEMENT — FORWARD SUMP DRAIN VALVE.**

a. Replace valve having cracks and damaged threads.

b. Replace valve having faulty shutoff operation.

**10-62. INSTALLATION — FORWARD SUMP DRAIN VALVE.**

a. Place packing (78, figure 10-2) on upper half of valve (78), insert in fitting assembly (74) and install nut (73).

b. Install packing (80) and lower half of valve (81) on upper half of valve (79).

c. Place packing (72) in position and install fitting assembly (74) using frangible dips (75) at 2 and 5 o'clock position, washers (76) and bolts (77). Torque bolts 50 TO 70 inch-pounds.

d. Conned hose (82) to lower half of valve (81).

**NOTE**

Aircraft only needs to be refueled to a level high enough to check sump drain valve for leakage.

e. Refuel aircraft (paragraph 1-3).

f. Inspect drain valve for leakage. If no leakage occurs, continue to refuel aircraft. If there is any evidence of leakage, recheck torque of bolts (77). If leakage is still present, repeat steps in Paragraph 10-59 through 10-62.

g. Install access cover.

**10-63. HOSES AND TUBING.****10-64. DESCRIPTION — HOSES AND TUBING.**

Flexible hoses of fire resistant material are used in the crashworthy fuel system. The crossover hose (14, figure 10-2), engine fuel inlet hose (11), fuel and vent fitting hoses (23) and cheek valve manifold to shutoff valve hose are self-sealing crashworthy hoses. The hoses are scoured with robber cushioned damp to prevent chafing. Aluminum alloy tubing is used in the system to serve as drain lines.

**10-65. REMOVAL — HOSES AND TUBING.**

a. Defuel forward and aft cells (paragraph 1-3).

b. Hold end fittings to prevent kinking or twisting of hoses and tubing when removing. Cover open ends to prevent contamination.

**10-66. INSPECTION — HOSES AND TUBING.**

a. Inspect tubing for kinks, dents, and deep scratches.

b. Inspect fuel crossover hose (14, figure 10-2) for:

(1) Any surface abrasion deep enough to cut outer fabric braid.

(2) Brittleness or powdering due to temperature or aging.

(3) Cracks, cuts, or tears.

(4) Hose saturated with fluid.

c. Inspect fuel crossover hose (14) for loose or damaged clamps attaching hose to end fitting. Inspect crossover hose (14) for damage.

d. Inspect vent lines (23) for:

(1) Two or more broken wires per plait or more than six broken wires per lineal foot or any broken wire where kinking is suspected.

(2) Evidence of dents, kinks, or twisting.

(3) Evidence of brittleness. Check by flexing hose.

(4) Seepage/wetness around the end fitting or any part of the hose.

e. Inspect self-sealing covered hoses (1, 8, and 10, figure 10-3).

(1) Surface abrasion deep enough to cut the outer fabric braid.

(2) Brittleness or powdering due to temperature or aging.

(3) Evidence of inner hose pulling out of the outer cover at end fittings. Inspect for reduction of inside diameter.

(4) Cracks, cuts, or tears in outer cover.

(5) Soaked outer cover, saturated with fluid.

f. Inspect self-sealing covered hoses (1, 8, and 10), for loose or damaged clamps at hose ends.

g. To check the inside diameter of a marginally kinked or dented hose for deformation, use ball size shown below and verify it will roll through the hose to indicate unrestricted flow.

Hose dash size	Ball size diameter (inches)
-3	0.080
-4	0.132
-5	0.200
-6	0.260
-8	0.350
-10	0.450
-12	0.575
-16	0.781
-20	1.015
-24	1.250
-32	1.684

h. Inspect remaining hoses for cuts, kinks, or twisted areas.

i. Inspect end fittings for damaged threads, burrs, or other damage.

#### 10-67. REPAIR OR REPLACEMENT – HOSES AND TUBING.

a. Replace hoses with indications of defects noted in paragraph 10-66.

b. Tighten or replace loose or damaged fuel hose clamps (paragraph 10-66).

c. Replace hoses having cuts, kinks, or twisted areas.

d. Replace tubing having kinks, dents, or deep scratches.

e. Replace hoses having damaged end fittings.

#### 10-68. INSTALLATION – HOSES AND TUBING.

a. Do not try to pull hoses or tubing into position by tightening nuts. Position tubes properly between connecting points to avoid stressing.

b. Hold end fittings when installing hoses. Ensure that hoses do not become twisted during tightening of end fittings.

#### 10-69. FUEL CELL FITTINGS.

#### 10-70. DESCRIPTION – FUEL CELL FITTINGS.

Fuel cell fittings include P F filler cap and adapter, M refueling receiver assembly, crossover tube

elbows, vents, pressure line outlets, fuel quantity transmitter, and governor bleed line inlet (figure 10-2).

#### 10-71. MAINTENANCE - FUEL CELL FITTINGS.

Any fuel cell fitting can be removed for replacement of parts to correct leaks, or for access to parts within cells. Observe the following:

a. Replace defective seal or packing under fitting. Be sure mating surfaces are clean and free of burrs and nicks.

#### NOTE

**Note position of frangible clips on system and reinstall in same location.**

b. If crossover hose elbow on aft cell is removed, make certain that check valve and pin are correctly reinstalled (figure 10-2).



**Ensure that check valve is installed with direction-of-flow arrow pointing into cell.**

c. If governor bleed return inlet fitting is removed from rear side of aft fuel cell, make certain of correct reassembly. Install check valve (35, figure 10-2) with direction-of-flow arrow pointing into the cell,

d. Torque bolts **50 TO 70** inch-pounds.

#### 10-72. INSPECTION - FUELL CELL FITTINGS.

Inspect for leakage after refilling fuell cells and during initial operation.

## SECTION II. FUEL CELLS

#### 10-73. FUEL CELLS.

#### 10-74. DESCRIPTION - FUEL CELLS.

a. The two fuel cells are removable units contained in fuselage compartments, one forward of the pylon and one aft, between the main longitudinal beams. The cells are crashworthy, self-sealing and have a 50 caliber ballistic protection level. Openings in the cells are provided with metal fittings bonded into the laminated cell walls. Each fitting has a pattern of threaded inserts for attachment of equipment and for securing cell in position by means of frangible clips.

b. Each fuel cell is designed to retain fuel in event of crash impact. The cell is constructed of high strength multiple ply material and incorporates self-sealing compound between plies. The cell is retained in the structure by frangible clips designed to break away before crash forces rupture the cell. High strength fittings are used to attach system components to the cell. The fuel cell is sufficiently flexible to permit installation in fuselage; yet is rigid enough to eliminate need for hangers or cord lacings.

#### 10-75. INSPECTION - ACCEPTANCE/ REJECTION CRITERIA - FUEL CELLS.

a. Defuel helicopter (paragraph 1-3).

#### NOTE

**The access panel just ahead of the wings can be removed without removal of the wings.**

b. **R**emove 12 screws (81, figure 10-2) securing cap and adapter assembly (82) to fuselage. Remove cap and adapter assembly (82).

c. **R**emove screws (24) securing refueling receiver assembly (26) to fuselage. Remove receiver (26) and retainer (27).

d. Feel the interior of the cell horizontal shelf all the way to the fuselage forward and aft vertical wall for activation (sponginess) (paragraph 10-78).

**CAUTION**

**Use safety precautions with electrical device. Use only a sealed battery powered light.**

e. A fuel cell may be questionable when inspected along the shelf area and additional inspection may be required. Additional inspection is performed by completely draining the fuel system and removing the fuel pump and frangible mounting clips around the cell fitting. The feel test is then performed inside and outside the cell bottom. In addition to any sponginess that may be detected from the inside, the cell wetness that can be felt on the bottom exterior is cause for cell removal and possible additional inspection.

**Premaintenance Requirements for Fuel Cells**

Conditions	Requirements
Model	AH-1S
Part No. or Serial No.	All
Special Tools	None
Test Equipment	None
Support Equipment	(S3) (S6)
Minimum Personnel Required	Two
Consumable Materials	(C12) (C74) (C75) (C53) (C102) (C52) (C117) (C29) (C107) (C112) (C137)
Special Environmental Conditions	70 degrees F (21 degrees C)

f. If the fuel cells have separated or activated per install new fuel cell.

g. If packing (29) or packing (84) was pulled from groove in the cell, replace packing.

h. If fuel cells are acceptable, install parts that were removed in steps b and c. Torque screws **45 TO 55** inch-pounds.

**10-76. REMOVAL - FORWARD FUEL CELL (AVIM).**

a. Defuel system and remove access panel (paragraph 1-3).

b. Disconnect electrical leads and remove boost pump assembly (paragraph 10-27).

c. Disconnect electrical leads of low level warning (float) switch (70, figure 10-2). Disconnect drain hose (80) from valve (79). Remove two bolts (77), washers (76), and frangible clips (75), securing cell to fuselage structure. Remove four remaining bolts (77) securing sump fitting (74) to fuel cell. Remove fitting (74) with drain valve (79) and low level warning (float) switch (70) from helicopter.

c1. Remove leftwing (Refer to Chapter 2).

d. Remove screw mounted access panel from left side of fuselage just ahead of wing.

e. Remove left and right side access panels located below wings. Loosen clamp on fuel crossover hose (14). Remove four bolts, frangible clips, washers, and spacers from bulkhead crossover flanges and fuel cell. Remove six bolts and washers from crossover and cell flange.

f. Open hydraulic compartment access doors.

g. Remove ECU (paragraph 13-9).

h. Remove fuel quantity transmitter probe (22) (paragraph 8-224).

i. Disconnect hose assemblies at vent (21) fuel fitting. Remove five bolts and frangible clips securing cell to fuselage structure. Remove remaining bolt securing fitting to fuel cell. Remove fitting from helicopter.

j. Remove refueling receiver assembly (26, figure 10-2), packing (29), retainer (27), gasket (28), and mounting screws (24) from fuselage. **2 E** Remove cap and adapter assembly (82), packing (84), retainer (83) and mounting screws (81) from fuselage.

k. Remove forged fitting, located on inner access panel near lower forward corner, by removing two bolts at base of fitting and four bolts and washers which secure fitting to panel. Keep bolts, radius block, and shim with fitting.

l. Remove screw-mounted inner panel from fuselage beam.

m. Remove screws which secure upper fuel cell access panel to left side of fuselage at contour. Remove panel.

n. Remove clamps and ties from structure and cable assemblies as necessary to obtain a clear area for cell removal from left side. Tie cable assemblies out of the way.

o. Collapse upper portion of fuel cell inward to clear beam. Collapse cell downward and remove from cavity.

p. Preserve fuel cell by fogging with oil (C77). Cover cell openings with barrier material (C23).

### **10-77. REMOVAL - AFT FUEL CELL. (AVIM)**

a. Defuel system and remove lower skin panel (paragraph 1-3).

b. Remove seal drain tube and boost pump (paragraph 10-27).

c. Disconnect electrical leads of low level warning (float) switch (36, figure 10-2). Remove nut (42) and cover (41). Remove two bolts (40) securing switch fitting (39) to cell. Remove fitting (39) and switch (36) from helicopter.

d. Remove clamp and hose (61) from defuel and sump drain valve (62). Remove two bolts (59), washers (58), and frangible clips (57) securing valve, plate (56), and cell to fuselage structure. Remove four remaining bolts (59) and washers (58) securing valve and plate to fuel cell. Remove valve and plate from helicopter.

e. Remove left and right side access panels located below wings. Loosen clamp on fuel crossover hose (14). Remove four bolts, frangible clips, washers, and spacers from bulkhead crossover flanges and fuel cell. Remove six bolts and washers from crossover and cell flange.

f. Remove oil cooler intake duct from left side of fuselage for access. Disconnect bleed line from check valve (35). Remove two bolts (38), frangible clips (32), and washers (34) securing plate (31) with check valve (35) attached) and cell to structure. Remove two bolts and washers securing plate to cell.

g. Open transmission cowling. Remove induction baffles for access to top ports of aft fuel tank cell (paragraph 2-125).

h. Disconnect hose assembly (23) by removing six bolts and frangible clips securing hose fitting to fuselage structure.

i. Remove fuel quantity transmitter (probe) (22) (paragraph 8-224). Remove four cell attachment screws and washers.

j. Disconnect fuel pressure line hose from tank outlet on left side of deck, forward of valve manifold. Remove two bolts and frangible clips securing fitting to fuselage structure. Remove two bolts and washers securing fitting to cell. Remove fitting from helicopter.

k. Install fitting and jack at aft jack point. Raise jack only until snug against fitting.



**Prior to removal of aft fuel cell access panel, perform procedure outlined in paragraph 2-5.**

l. Remove mounting screws and aft fuel cell access panel from right side of fuselage directly behind wing attachments.

m. Collapse and remove fuel cell.

**n. Preserve fuel cell by fogging with oil (C77). Cover cell openings with barrier material (C23).**

### **10-78. INSPECTION - BOTH CELLS. (AVIM)**

a. Inspect all interior and exterior surfaces for loose seams, cuts, abrasions, scuffed surfaces, tears, blisters, and for any area that appears to have become soaked with fuel (activated).

#### **NOTE**

**An activated fuel cell is a cell that has absorbed fuel in the inner liner. The walls of the cell are flabby and spongy. The inner liners are separated and ballooned from the structure. It must be understood that a serviceable cell may have blemishes. These blemishes do not have a spongy feeling. These blemishes are not cause for rejection.**

b. Inspect metal fittings to make certain protective finishes are intact and the coil-type inserts are installed and in good condition.

c. The following damages are prohibited for field repair and can be repaired only by an authorized fuel cell overhaul facility.

(1) Pass through holes (holes made by a projectile that enters through one surface of the fuel cell and exits through the opposite surface).

(2) Damage that extends into a corner or stepped-off area or that involves a cut longer than 2.0 inches, or that is caused by the seepage or diffusion of fuel between the fabric plies.

### 10-79. CLEANING - FUEL CELLS (AVIM)

a. Remove surface dirt and grime by scrubbing the fuel cell with warm, soapy water. Air dry surface.

b. Purge fuel cell thoroughly with fresh air; scrub and rinse with warm, soapy water; and rinse in clean, clear water. Air dry.

### 10-80. REPAIR OR REPLACEMENT - FUEL CELLS (AVIM).

#### WARNING

**Make no repairs on the radius of a cell or in the fitting area of a cell. Cells with such damage should be forwarded to depot for repair. No damage area larger than two inches should be repaired at AVIM.**

#### WARNING

**Cleaning solvent is flammable and toxic. Provide adequate ventilation. Avoid prolonged breathing of solvent vapors and contact with skin or eyes,**

a. Use a piece of fabric (C53) large enough to cover damage at least 2.0 inches from cut in any direction. Buff this material lightly and thoroughly with sandpaper (C102) and wash with MEK (C74) to remove buffing dust.

b. Apply two coats of cement (C29) to the buffed area. Allow each coat to dry **10 TO 15** minutes.

#### WARNING

**Cleaning solvent is flammable and toxic. Provide adequate ventilation. Avoid prolonged breathing of solvent vapors and contact with skin or eyes.**

c. Buff cell area to be patched lightly and thoroughly with sandpaper (C102) and wash with MEK (C74) to remove buffing dust.

d. Apply two coats of cement (C29). Allow each coat to dry **10 TO 15** minutes.

#### WARNING

**Cleaning solvent is flammable and toxic. Provide adequate ventilation, Avoid prolonged breathing of solvent vapors and contact with skin or eyes.**

e. Freshen cemented area of patch and cemented area of cell with MEK (C74).

f. While still tacky, apply edge of patch to edge of cemented area on the cell. With a roller or blunt instrument roll or press the patch to the cemented area on the cell. Hold part of the patch off the cemented area and roll or press it down **0.50 TO 1.0** inch across at a time so as not to trap air between patch and cell.

g. Seal coat edge of patch **0.50** inch with one coat of cement (C29) and allow the patch to remain undisturbed for **six** hours.

h. After the damaged area has been patched on the outside of the cell and the repair allowed to stand a minimum of six hours, the cell is then ready to have the patch applied on the inside of the cell.

#### WARNING

**Cleaning solvent is flammable and toxic. Provide adequate ventilation. Avoid prolonged breathing of solvent vapors and contact with skin or eyes.**

i. Lightly and thoroughly buff a piece of fabric (C52) large enough to cover damage at least 2.0 inches from cut in any direction. Wash buffing dust off patch with MEK (C74).

j. Apply two coats of cement (C29) to patch, opposite red fabric side. Allow each coat to dry 10 TO 15 minutes.



Cleaning solvent is flammable and toxic. Provide adequate ventilation. Avoid prolonged breathing of solvent vapors and contact with skin or eyes.

k. Buff cell area to be patched lightly and thoroughly with sandpaper (C102) and then wash off buffing dust with MEK (C74).

l. Apply two coats of cement (C29) to buffed area and allow each coat to dry 10 TO 15 minutes.



**Cleaning solvent is flammable and toxic. Provide adequate ventilation. Avoid prolonged breathing of solvent vapors and contact with skin or eyes.**

m. Freshen cemented area of patch and cemented area of cell with MEK (C74).

n. While still tacky, apply edge of patch to edge of cemented area, centering patch over cut in cell. Hold part of patch off the cemented area and roll or press it down 0.50 TO 1.0 inch across at a time so as not to trap air between patch and cell.



**Cleaning solvent is flammable and toxic. Provide adequate ventilation. Avoid prolonged breathing of solvent vapors and contact with skin or eyes.**

o. Remove red fabric from patch by moistening with MEK (C74).

p. Seal coat patch and area 0.50 inch from edge of patch with two coats of cement (C29). Allow the first coat to dry 15 minutes and the second coat to dry 12 hours or more.

**10-81. INSTALLATION - FORWARD FUEL CELL (AVIM).**

a. Check fuselage cavity, including access panels, for any foreign objects or rough surfaces which could damage fuel cells.



Cleaning solvent is flammable and toxic. Provide adequate ventilation. Avoid prolonged breathing of solvent vapors and contact with skin or eyes.

b. Wipe surfaces with a cloth saturated with solvent (C112) and wipe dry with a clean cloth before solvent evaporates. Use MEK (C74) on bare metal surfaces, naphtha (C75) on surfaces of other materials.

c. Remove old sealing compound from edges of access panels and mating surfaces on structure.



**Do not fold the fuel cell if the ambient temperature of the work area is less than 70 degrees F (21 degrees C). Move cell into warm area before folding cell. Do not allow the fuel cell to remain in its folded condition for more than 30 minutes. Non-visible permanent damage to cell walls may occur. Do not use wire or other thin diameter material to restrain cell, permanent damage to self-sealing characteristics of the cell could result.**

d. Partially flatten fuel cell by pushing in on sides allowing cell to collapse downward (see figure 10-5). Apply straps or large diameter ropes vertically around cell to temporarily retain this shape. Sprinkle with talc (C117) and place fuel tank cell in cavity, remove straps or ropes and allow cell to expand. Align all fittings with openings in structural panels.

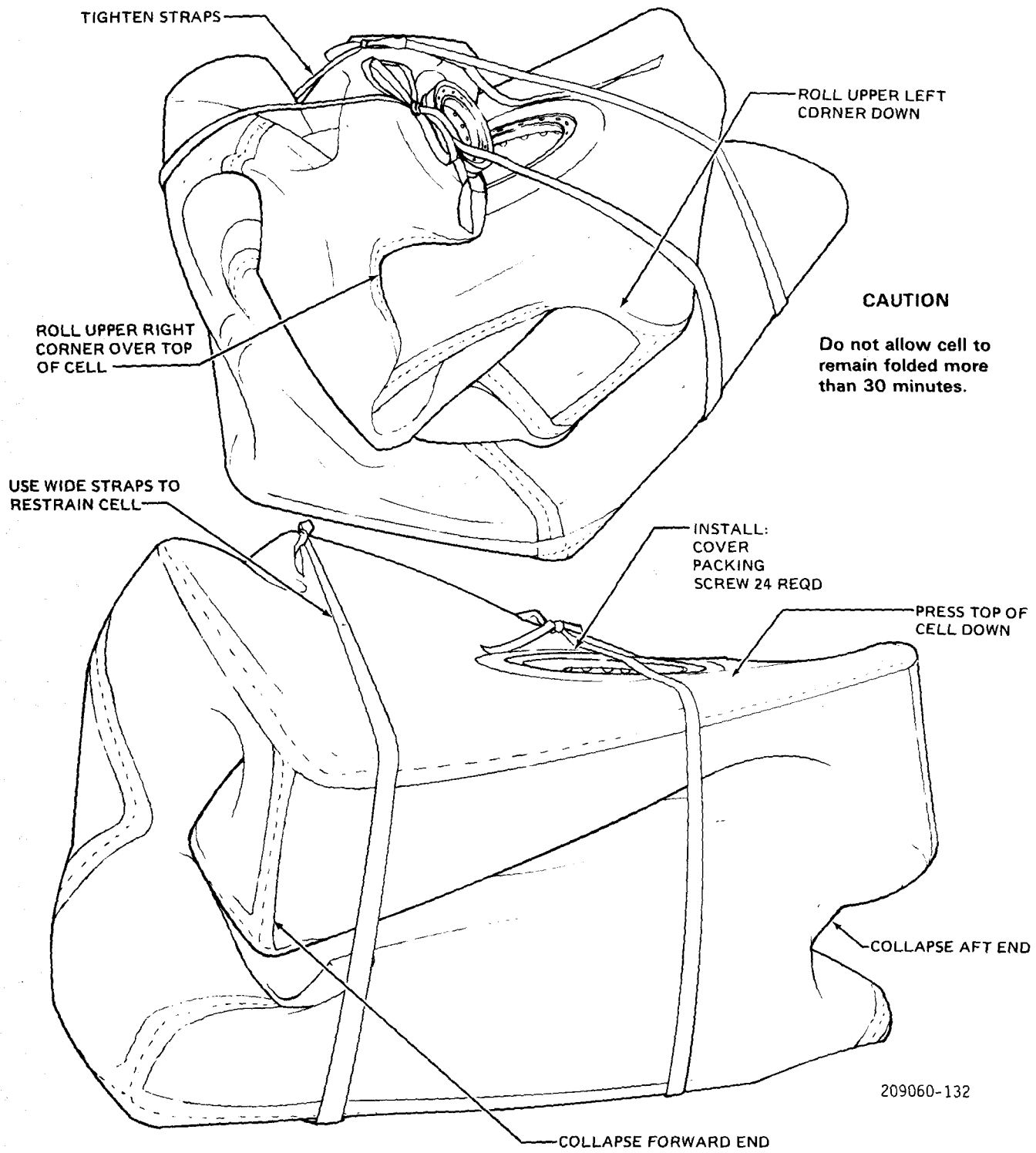

Figure 10-5. Collapsing Forward Fuel Cell



**NOTE**

The materials and construction features of the cells used in the crashworthy system results in fuel cells that are rigid and self-supporting. Ease of installation of the cells is related to temperatures of the cells and the work area. As a general rule a temperature above 70 degrees F (21 degrees C) is desirable in the work area when installing the cells. Heat can be applied to the cell provided a temperature of 120 degrees F (49 degrees C) is not exceeded.

**NOTE**

A "T" handle, fabricated per figure 10-6, can be used to align fuel cell fittings to structure openings. The tool is inserted through the hole in the structure and screwed into the fitting. Manipulate the fitting as desired by grasping the "T" handle.

**NOTE**

In the following instructions do not tighten bolts securing frangible clips to structure until all clips have been installed and fuel cell properly positioned. To ensure a satisfactory seal at bolted connections, alternately snug up and torque opposite bolts at each connection.

e. Install vent and fuel discharge fitting (21, figure 10-2) and hose (15) in fuel cell access cover-at hydraulic compartment floor.

f. Install fuel quantity transmitter (probe) (22) (paragraph 8-226).

g. Install retainer (27, figure 10-2), gasket (28), packing (29) and refueling receiver assembly (26) at right side of fuselage. **P** **E** Install retainer (83), packing (84), cap and adapter assembly (82) at right side of fuselage.

h. Connect fuel hose and install boost pump assembly (13) (paragraph 10-30).

i. Install drain valve and low level warning (float) switch fitting in fuel cell and helicopter structure. Lockwire drain valve (C137).

j. Install fuel crossover hose to cells and helicopter structure. Install clamp.

k. Install drain hose to valve (17). Install clamp.

l. Adjust position of cell in cavity so that all frangible clips are bearing on helicopter structure. Torque bolts securing clips to cell and structure **45 TO 55** inch-pounds.

m. Position inner access panel to opening in left main beam. Apply sealing compound (C107) to provide fume-tight seal between mating surfaces. Install screws and thin aluminum alloy washers.

n. Position forged tension fitting on matching holes near lower forward corner of beam access panel. Reinstall shim under base of fitting. Install high-tensile bolt (NAS 624-14), with radius block under head, in aft bolt hole of base. Install bolt (NAS 1304-8), with thin steel washer, in forward bolt hole of base. Install four bolts, with thin steel washers, through upright leg of fitting into inserts of panel.

o. Connect electrical leads of low level warning (float) switch, boost pump, and transmitter (Appendix E).

p. Return cable assemblies installation to original configuration at left side access panel.

q. Install outer access panel with screws on fuselage ahead of wing location.

r. Install left wing (paragraph 2-343).

s. Install access panels below wings and on lower skin.

**10-81.1. PRESSURE TEST FUEL SYSTEM.****CAUTION**

**Do not use masking tape to seal openings.**

a. Cap main fuel lines and vent connections.

b. Use regulated low pressure (3/4 to 1 PSI, IAW TM 55-1500-204-25/1) filtered, compressed air source with manometer or accurate gage and shutoff valve,

**CAUTION**

**Do not apply excessive pressure, as severe damage to cell and structure may result.**

c. Apply pressure until gage indicates 3/4 to 1 PSI in cells and crossover tubes. Shut off air pressure. Cells should hold this pressure for 15 minutes.

d. Locate and correct any leakage indicated by loss of pressure, and repeat tests until results are satisfactory.

e. Refuel aircraft.

**CAUTION**

**Do not operate electrical equipment while defueling or refueling aircraft.**

**10-82. INSTALLATION - AFT FUEL CELL (AVIM).**

a. Check fuselage cavity, including access panel for freedom from foreign objects or rough surfaces which could damage fuel cell.

**WARNING**

**Cleaning solvent is flammable and toxic. Provide adequate ventilation, Avoid prolonged breathing of solvent vapors and contact with skin or eyes.**

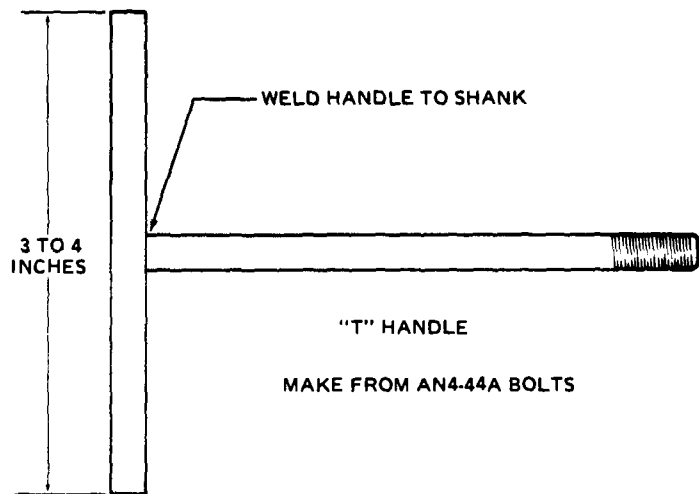
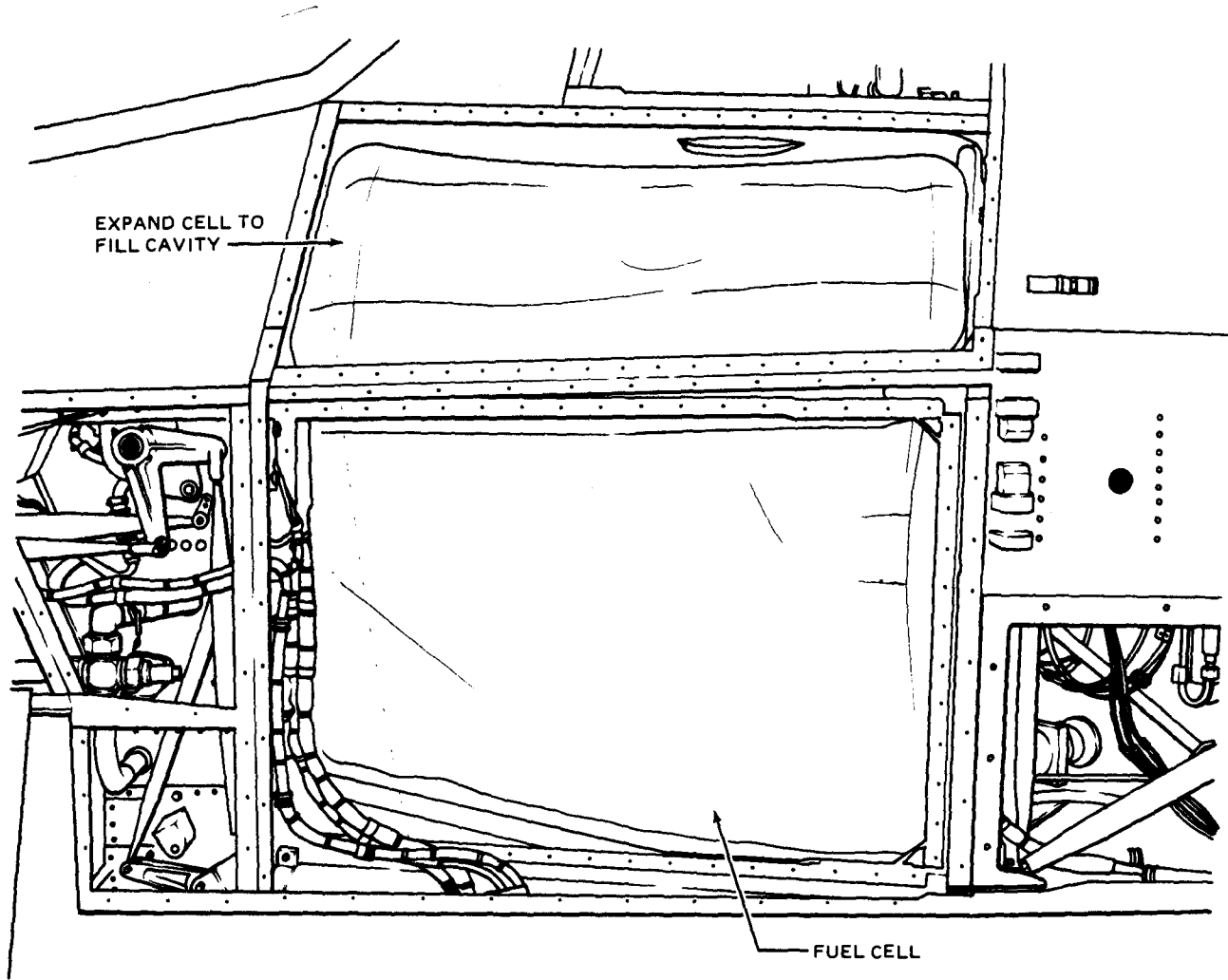

209060-131

Figure 10-6. Installed Forward Fuel Cell

b. Wipe surfaces with a cloth saturated with solvent (C112) and wipe dry with a clean cloth before solvent evaporates. Use MEK (C74) on bare metal surfaces, and naphtha (C75) on surfaces of other materials.

c. Remove old sealing compound from edges of access panel and mating surface on structure.

### **CAUTION**

**Do not fold the fuel cell if the ambient temperature of the work area is less than 70 degrees F (21 degrees C). Move cell into warm area before folding cell. Do not allow the fuel cell to remain in its folded condition for more than 30 minutes. Nonvisible permanent damage to cell walls may occur. Do not use wire or other thin diameter material to restrain cell, as permanent damage to self-sealing characteristics of the cell could result.**

d. Partially flatten fuel cell by pushing in on sides, allowing cell to collapse downward (figure 10-7). Apply straps or ropes vertically around cell to temporarily retain this shape. Sprinkle with talc (C117) and place fuel tank cell in cavity, remove straps or ropes and allow cell to expand. Align all fittings with openings in structural panels.

### **NOTE**

**In the following instructions do not tighten bolts securing frangible clips to structure until all clips have been positioned. To ensure a satisfactory seal at bolted connections, alternately snug up and torque opposite bolts at each connection.**

e. Apply sealing compound (C107) to provide fume-tight seal between mating of access panel and fuselage. Install panel with mounting screws.

f. Install vent fitting in fuel cell access cover and secure to helicopter with six bolts, washers and frangible clips. Connect hose.

g. Install fuel quantity transmitter probe (paragraph 8-226).

h. Install fuel pressure line fitting in fuel cell with two bolts and washers. Secure fitting and cell to helicopter structure with two bolts, washers, and frangible clips. Connect hose.

i. Install governor bleed line check valve and plate to fuel cell with two bolts and washers. Secure plate to helicopter structure with two bolts, washers, and frangible clips. Connect hose.

j. Install boost pump and drain tube (paragraph 10-30).

k. Install low level warning (float) switch fitting with two washers and bolts. Secure fitting and cell to helicopter structure. Install nut and cover securing switch fitting to helicopter structure.

l. Install defuel and dump drain valve in fuel cell with four washers and bolts. Secure valve, plate, and cell to structure with two bolts, washers, and frangible clips. Install drain hose and clamp. Lockwire drain valve.

m. Install fuel crossover hose to fuel cell with six bolts and washers. Alternately snug up and torque opposite bolts to ensure a satisfactory seal. Install crossover hose and cell to fuselage structure with four bolts, washers, spacers, and frangible clips. (See note above.) Torque bolts **45 TO 55** inch-pounds. Install clamp on crossover hose.

n. Install induction baffles (paragraph 2-128).

o. Close left and right side access panels below wings.

p. Remove jack.

### **10-83. PRESSURE TEST FUEL SYSTEM.**

### **CAUTION**

**Do not use masking tape to seal openings.**

a. Cap main fuel lines and vent connections.

b. Use regulated low pressure (3/4 PSI, IAW TM 55-1500-204-23 (Series) filtered, compressed air source with manometer or accurate gage and shut off valve.

### **CAUTION**

**Do not apply excessive pressure, as severe damage to cell and structure may result.**

c. Apply pressure until gage indicates 3/4 to 1 PSI in cells and crossover tubes. Shut off air pressure. Cells should hold this pressure for 15 minutes.

d. Locate and correct any leakage indicated by loss of pressure, and repeat tests until results are satisfactory.

e. Refuel aircraft.

### **CAUTION**

**Do not operate electrical equipment while defueling or refueling aircraft.**

**CAUTION**

**Do not allow cell to remain folded more than 30 minutes.**

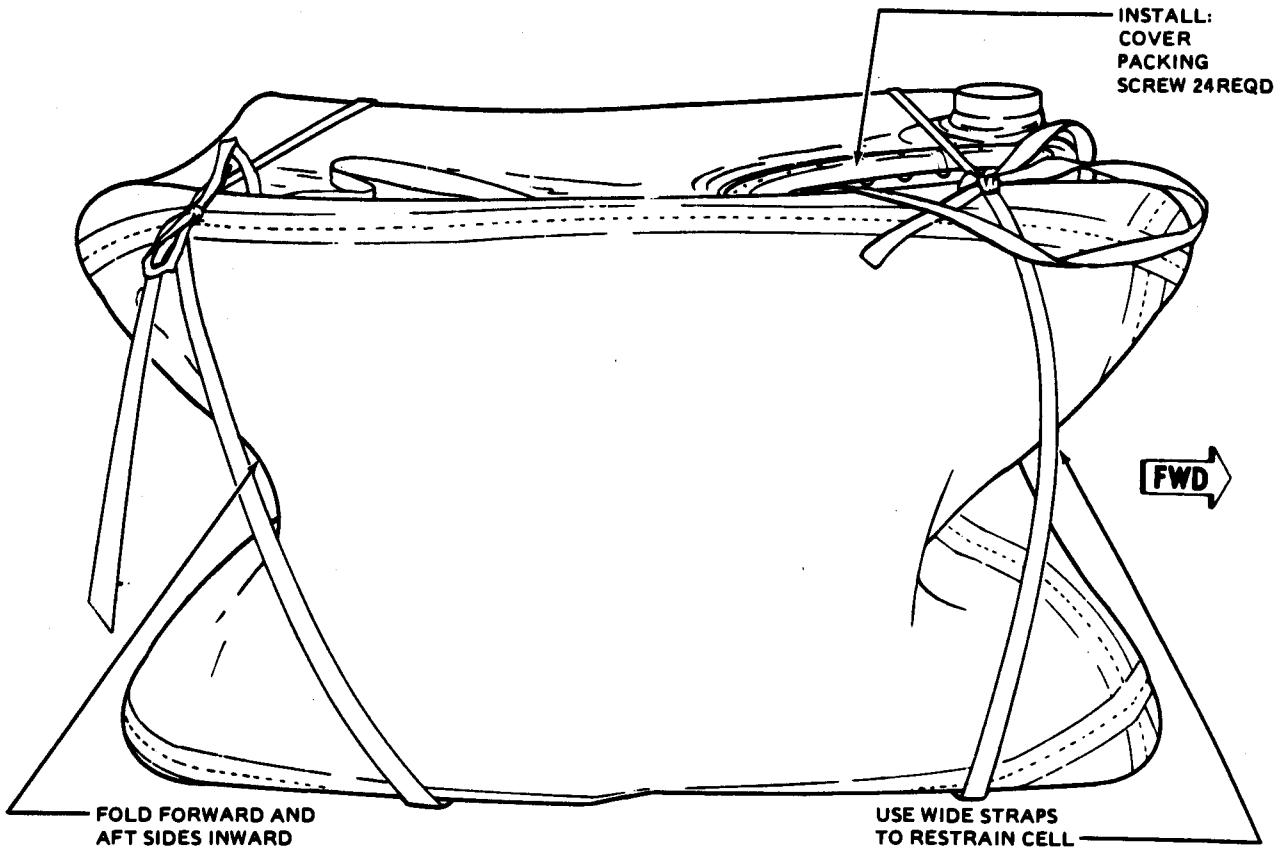

209060-130

Figure 10-7. Collapsing Aft Fuel Cell

## CHAPTER 11

### FLIGHT CONTROLS

---

#### SECTION 1. FLIGHT CONTROLS

**11-1. FLIGHT CONTROL SYSTEM.**

**11-2. DESCRIPTION - FLIGHT CONTROL SYSTEM.**

The primary flight control systems are the main rotor collective, fore-and-aft cyclic and lateral cyclic, and tail rotor controls. Each of these is a system of mechanical linkage, assisted by hydraulic cylinders, connecting the pilot and gunner control sticks and pedals to those mechanisms which rotate with and directly control the main rotor and tail rotor. Main rotor cyclic and tail rotor controls incorporate electrically operated magnetic brakes and force trims

to steady the stick and pedals against movement of their own accord and to induce artificial control feel. The main rotor cyclic and tail rotor controls also incorporate a stability and control augmentation system (SCAS). The operator has the option to use the SCAS system or to turn it off at the SCAS control panel. A separate system of control linkage for operation of the synchronized elevator is attached to the fore-and-aft cyclic control at the swashplate.

**11-3. TROUBLESHOOTING - FLIGHT CONTROL SYSTEM.**

The following table is provided as an aid in adjusting cyclic and collective sticks for proper feel and tension.

**NOTE**

**Before using this table, be sure all normal operational checks have been accomplished. If a malfunction is detected which is not listed in this table, notify the next higher maintenance level.**

**Table 11-1. Troubleshooting Flight Control System**

---

CONDITION

TEST OR INSPECTION

**CORRECTIVE ACTION**

1. Collective stick light or heavy on downstroke.

STEP 1. Check balance spring on collective cylinder for proper adjustment (paragraph 11-7).

**If force is not equal, adjust balance spring (paragraph 11-7).**

STEP 2. Check friction clamp and/or friction nut for proper adjustment (paragraph 11-16).

**If adjustments are not within limits, adjust friction clamp and nut (paragraph 11-16).**

2. Cyclic feels loose, has tendency to fall to left or right.

**Table 11-1. Troubleshooting Flight Control System (Cont)**

---

CONDITION

TEST OR INSPECTION

CORRECTIVE ACTION

STEP 1. Check friction nut adjustment.

If friction nut is loose, adjust nut (paragraph 11-37).

STEP 2. Check tension on force gradient spring.

If tension is weak, replace spring (paragraph 11-68).

3. Gunner cyclic stick will not remain in a fixed position.

STEP 1. Check for a weak or damaged gunner longitudinal cyclic control spring in the gunner longitudinal cyclic controls.

If spring is weak or damaged, replace spring (paragraph 11-159).

STEP 2. Check for weak or damaged gunner lateral cyclic control springs in the gunner lateral cyclic controls.

If springs are weak or damaged, replace springs (paragraphs 11-159).

**4. Flight controls binding.**

STEP 1. Check for obstructions or foreign objects,

Reposition or remove obstructions. Remove foreign objects,

STEP 2. Isolate binding component in collective system by detaching tube assemblies from bellcranks and collective sticks. Actuate each component to detect binding part.

Remove, replace, or repair defective parts (paragraphs 11-145 and 11-1 48).

STEP 3. Isolate binding component in cyclic system by detaching tube assemblies from bellcranks, cyclic sticks, magnetic brakes, and jackshaft. Actuate each component to detect binding part.

Remove, replace, or repair defective parts (paragraphs 11-26 and 11-1 48).

STEP 4. Isolate binding component in tail rotor control system by detaching tube assemblies from bellcranks and magnetic brake. Actuate each component to detect binding part.

Remove, replace, or repair defective parts (paragraphs 11-71 and 11-1 48).

STEP 5. Isolate binding component in elevator control system by detaching tube assemblies from bellcranks, walking beams and horn assembly. Actuate each component to detect binding part.

Remove, replace, or repair defective parts (paragraphs 11-136 and 11-1 48).

**11-4. COLLECTIVE SYSTEM.**

**11-50 DESCRIPTION - COLLECTIVE SYSTEM.**

The collective controls system includes gunner and pilot collective stick assemblies, tube assemblies, bellcranks, and a dual hydraulic cylinder. The hydraulic cylinder is connected to the collective lever which actuates the mast-mounted scissors and sleeve assembly to control pitch of the main rotor blades.

**Premaintenance Requirements for Collective Controls**

Conditions	Requirements
Model	AH-1S
Part No. or Serial No.	All
Special Tools	None
Test Equipment	None
Support Equipment	(S2)
Minimum Personnel Required	Two
Consumable Materials	(C43), (C138)
Special Environmental Conditions	N/A

**11-6. INSPECTION - COLLECTIVE SYSTEM.**

a. Inspect control system in place for secure installation, damage, chafing, and freedom of operation through full travel.

b. If required, remove components for detailed inspection. Refer to paragraphs 11-8, 11-17, and 11-145 thru 11-154.

**11-7. RIGGING - COLLECTIVE SYSTEM.**

a. Accomplish rigging without hydraulic power unless otherwise stated.

b. Install all components of the collective control system with the following exceptions:

(1) Leave hydraulic cylinder (2, figure 11-1) disconnected from collective lever (1).

(2) Leave tube assembly (5) disconnected from bellcrank (7).

(3) Leave tube assembly (6) disconnected from bellcrank (7).

c. Adjust tube assembly (10) to length of **22.13** inches between clevis hole centers and install in helicopter. Coat clevis threads with corrosion prevention compound (C43) when adjusting tube assembly.

d. Check breakaway force on collective lever (1) and adjust friction collet on mast if required. Refer to paragraph 5-63i for correct breakaway force and procedure to adjust friction.

e. Place pilot collective control stick (13) full down and apply stick friction to hold in position.

f. Loosen jamnut at upper end of tube assembly (5). Push tube assembly (5) up to bottom out valve lever in full up position (detail D). Hold, pressure on tube assembly (5) to keep piston and valve lever bottomed in full up position. Bottom out piston against top of cylinder (2). Adjust length of tube to fit on bellcrank (7), then shorten length by three full turns to assure that piston will not bottom out during operation. Connect tube assembly (5) to bellcrank (7) and tighten jam nut on tube assembly. Valve lever will now be near full down position.

g. Check rod end on tube assembly (5) to ensure that there is not more than **1.25** inch exposed threads (detail C). If more than **1.25** inches of threads are exposed, adjust length of tube assembly (10). Do not exceed one inch of exposed threads on (10) (detail B). Ensure that nut and bolt that attaches control tube (5) to hydraulic cylinder valve (4) is tightened sufficiently to remove axial play only. Back off to first castellation. Do not clamp clevis. The bolt must turn freely and cotter pin must be installed.

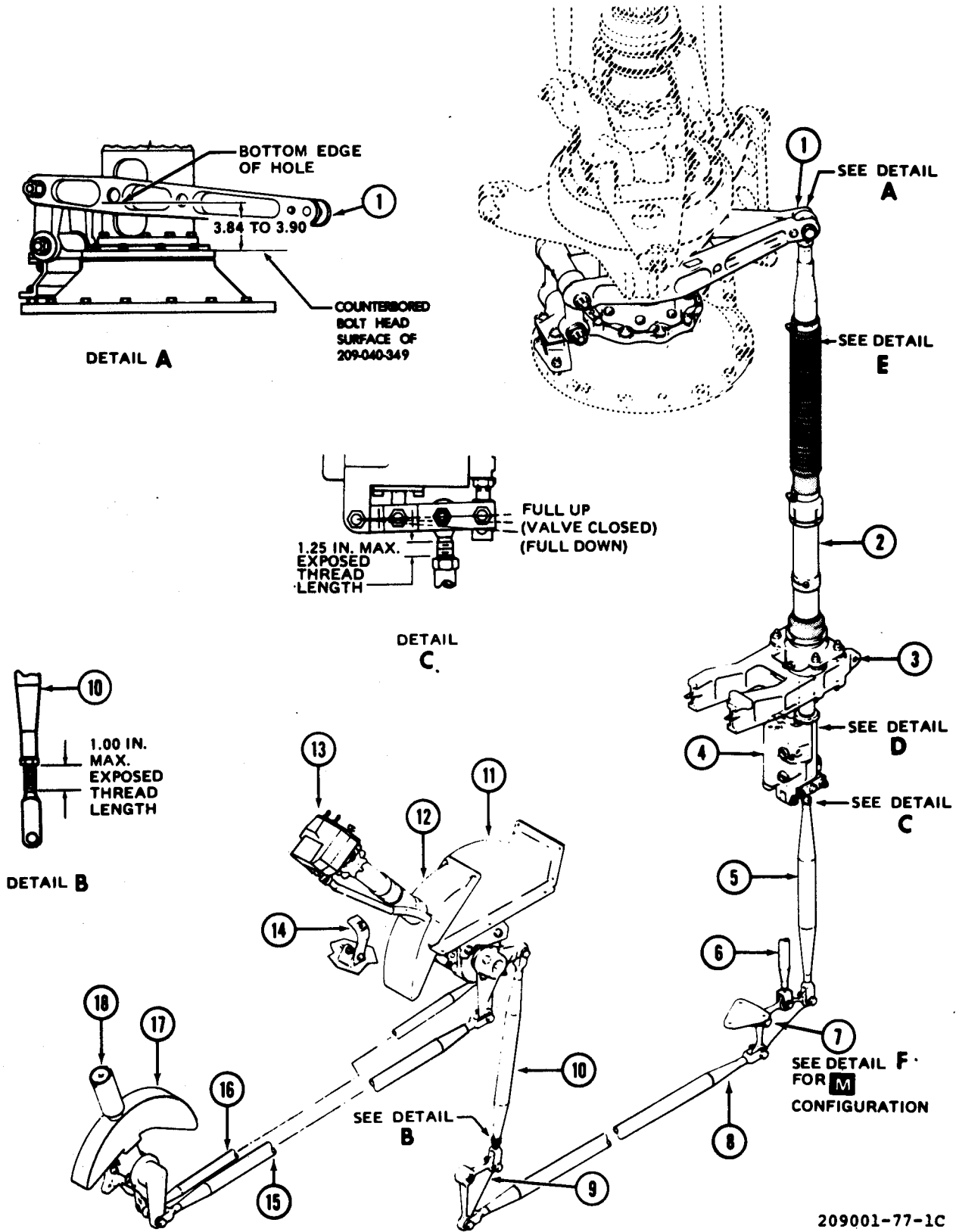

209001-77-1C

ALL DIMENSIONS ARE IN INCHES UNLESS OTHERWISE

Figure 11-1. Collective Controls (Sheet 1 of 2)



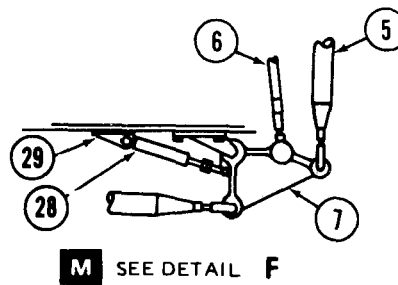
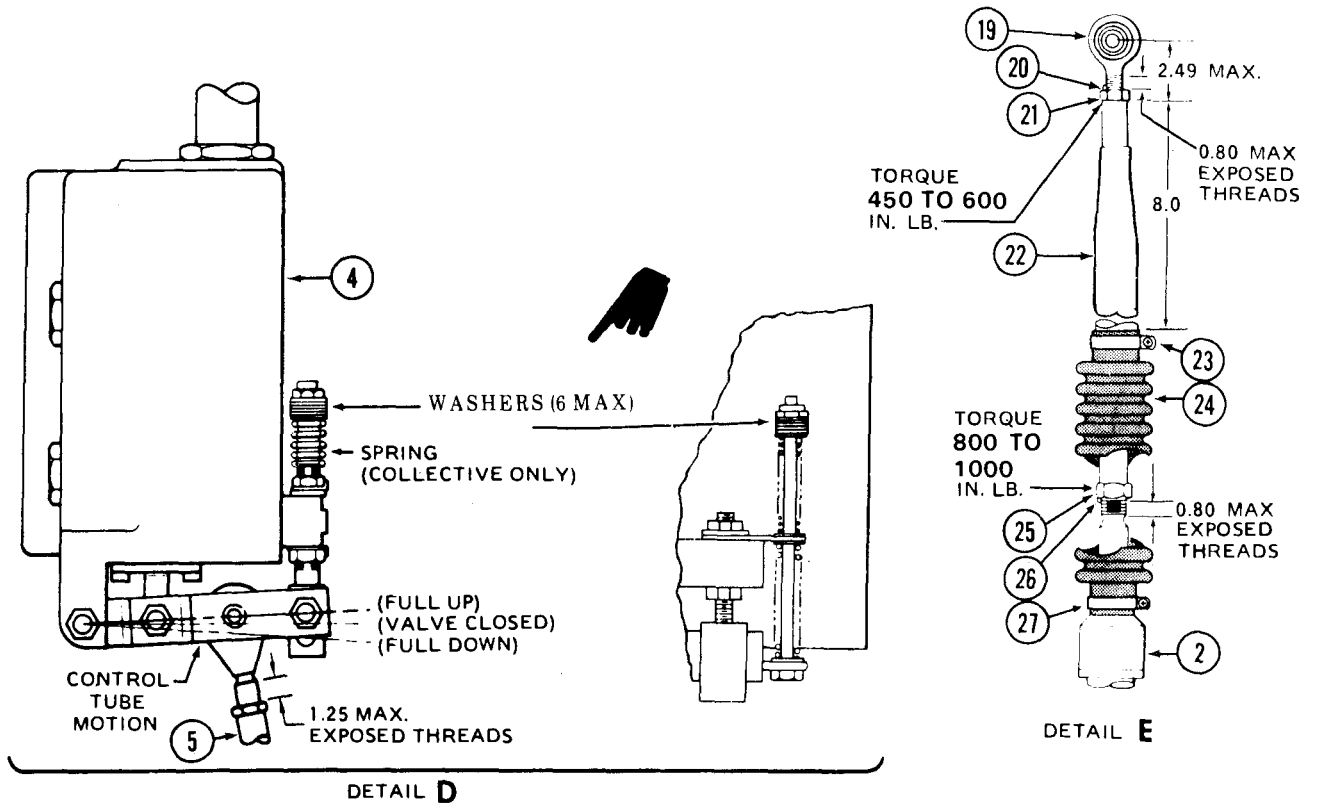

ALL DIMENSIONS ARE IN INCHES UNLESS OTHERWISE NOTED

- |                                    |                                     |                          |
|------------------------------------|-------------------------------------|--------------------------|
| 1. Collective lever                | 11. Cover                           | 21.                      |
| 2. Hydraulic cylinder assembly     | 12. Boot                            | 22. Extension tube       |
| 3. Cylinder support                | 13. Pilot collective control stick  | 23. Clamp                |
| 4. Hydraulic cylinder valve        | 14. Down - lock strap               | 24. Boot/flange assembly |
| 5. Tube assembly                   | 15. Tube assembly                   | 26. Nut                  |
| 6. Droop compensator tube assembly | 16. Tube assembly                   | 26. Lock                 |
| 7. Bellcrank and support           | 17. Boot                            | 27. Clamp                |
| 8. Tube assembly                   | 18. Gunner collective control stick | 28. <b>M</b> Transducer  |
| 9. Bellcrank                       | 19. Rod end bearing                 | 29. <b>M</b> Bracket     |
| 10. Tube assembly                  | 20. Lock                            |                          |

Figure 11-1. Collective Controls (Sheet 2 of 2)

**h.** Adjust extension tube (22), rod end bearing (19) and attach to collective lever as follows:

**(1)** Position collective lever (1, figure 11-1) to **3.84 TO 3.90** inch dimension as shown on detail A.

**(2)** Remove lockwire and loosen nut (21).



Maintain collective stick in full down position.

**(3)** Ensure that collective lever (1) is in position set in step (1). Push down on extension tube (22) with approximately 100 pounds of force until tube movement stops (approximately **0.060 TO 0.130** inch). Maintain this position and adjust rod end bearing (19) to fit on collective lever (1), then shorten one full turn of rod end bearing (19) to compensate for change that occurs when hydraulic power is applied.

**(4)** Measure exposed threads on rod end bearing (19). If lock (20) can be installed and if less than 0.80 inch of thread is exposed, torque nut (21) **450 to 600** inch-pounds, lockwire nut to lock (20) with lockwire (C138) and proceed to step (6): If there are insufficient exposed threads to install lock (20) or if exposed threads on rod end bearing (19) are in excess of 0.80 inch, make adjustment at nut (25) as outlined in step (5).

**(5)** If exposed threads on rod end bearing (19) were in excess of 0.80 inch in preceding step, make adjustment at nut (25) as follows:

**(a)** Thread rod end bearing (19) into tension tube (22) until **0.80** inch of threads are exposed. Torque nut (21) **450 TO 600** inch-pounds and lockwire to lock (20) with lockwire (C138).

**(b)** Loosen clamps (23) and (27). Slide boot (24) up until nut (25) is exposed, Remove lockwire and loosen nut (25).



Maintain collective stick in full down position.

**(c)** Ensure that collective lever (1) is at position, set in step (1). Push down on extension tube (22) with approximately **100** pounds of force. Maintain this position and adjust extension tube (22) on hydraulic cylinder assembly (4) to length so rod

end bearing (19) will fit on collective lever (1), then shorten one full turn of extension tube (22) to compensate for change that occurs when hydraulic power is applied.

**(d)** Tighten nut (25) and measure length of exposed threads. Maximum acceptable exposed thread is 0.80 inch.

**(e)** Torque nut (25) **800 TO 1000** inch-pounds and lockwire nut (25) to lock (26) with lockwire (C138).

**(f)** Position top of boot (24) **8.0** inches from top of extension tube (22) as shown on detail E and tighten clamp (23). Position lower end boot (24) on hydraulic cylinder assembly (2) and tighten clamp (27).

**(6)** Attach rod end bearing (19) to collective lever (1). Comply with procedure outlined in paragraph 7-66.

**i.** Check low pitch blade angle of main rotor to ensure it is within limits (paragraph 5-14).

**j.** Check complete collective control system for security and safetying of components.

**k.** Apply hydraulic power with ground test unit (S2). Check operation of controls through full range of travel. Check pilot collective control stick for correct friction adjustments (paragraph 11-16).

**l.** With a force gage (fish scale), check for approximate equal force required to raise or to lower collective control stick with hydraulic boost on. If necessary, adjust by adding or removing AN960-10 washers at top of spring on hydraulic cylinder valve (detail D). A maximum of six AN960-10 washers can be used.

**NOTE**

**The adjusting washers are in addition to the four washers used for assembly.**

**m.** Connect droop compensator tube assembly (6) to bellcrank (7).

**n.** Deleted.

**o.** Deleted.

**p.** Install access covers.



**K747 main rotor blades have a tendency to attain a higher percent RPM during autorotation than B540 main rotor blades. DO NOT RIG beyond the limits established in paragraph 5-14, to obtain a lower main rotor percent RPM.**

q. Perform maintenance test flight (TM 55-1520-236-MTF).

**11-8. PILOT COLLECTIVE STICK.**

**11-9. DESCRIPTION - PILOT COLLECTIVE STICK.**

The pilot collective control stick is on the left side console. There is a split switch box at the top with an electrical cable extending down past the base of the stick. A support assembly at the base of the collective stick houses the collective friction shoes, a collective lever and a throttle lever. Located between the base of the stick and the top is a throttle friction nut, throttle grip, collective friction nut, and a boot and support assembly. A strap (14, figure 11-1) is provided to secure the control stick in low pitch position. The pilot collective stick has a mechanical advantage of **1.1 TO 1** ratio over the gunner collective stick.

**Premaintenance Requirements for Pilots Collective Stick**

Conditions	Requirements
Model	AH-1S
Part No. or Serial No.	All
Special Tools	(T61)
Test Equipment	None
Support Equipment	(S2)
Minimum Personnel Required	Two
Consumable Materials	(C5), (C31), (C37), (C88), (C91), (C102), (C112), (C138)
Special Environmental Conditions	None

**11-10. REMOVAL - PILOT COLLECTIVE STICK (AVIM).**

a. Remove cover (4, figure 11-2) with attaching screws (2) and washers (3).

b. Remove screw-mounted panel (figure 2-3) from left side of fuselage for access to lower end of stick assembly.

c. Disconnect collective system tube assemblies (8, figure 11-2) from collective lever (5) and throttle system tube assemblies (7) from throttle lever (6), by removing bolts, nuts, and washers.

d. Disconnect electrical cable connector (19).

e. Remove bolt (11), screw (12), nuts (15), washers (14), and shims (13) which secure outboard stick support (9) to structure. Measure and record thickness of shims (13). Tag shims (13) for installation in same location.

f. Remove three bolts (16), washers and shim (18) from inboard support (10). Measure and record thickness of shim (18). Tag shim for installation in same location.

g. The following may be accomplished to ease removal of collective stick. Remove pin (2, figure 11-3) and lift control heed (1) and electrical harness (5) from pilot collective stick.

h. Move collective stick (1, figure 11-2) down through console to remove from helicopter.

**11-11. DISASSEMBLY - PILOT COLLECTIVE STICK (AVIM).**

a. Remove six countersunk screws (3, figure 11-3) attaching forward and aft boots (4 and 27) to boot support assembly (25). Remove boots.

b. Remove nuts (18), washers (16 and 17), and two bolts (15) that attach collective lever assembly (19) to elbow assembly (20). Pull lever off elbow.

c. Disconnect plug in electrical harness (5).

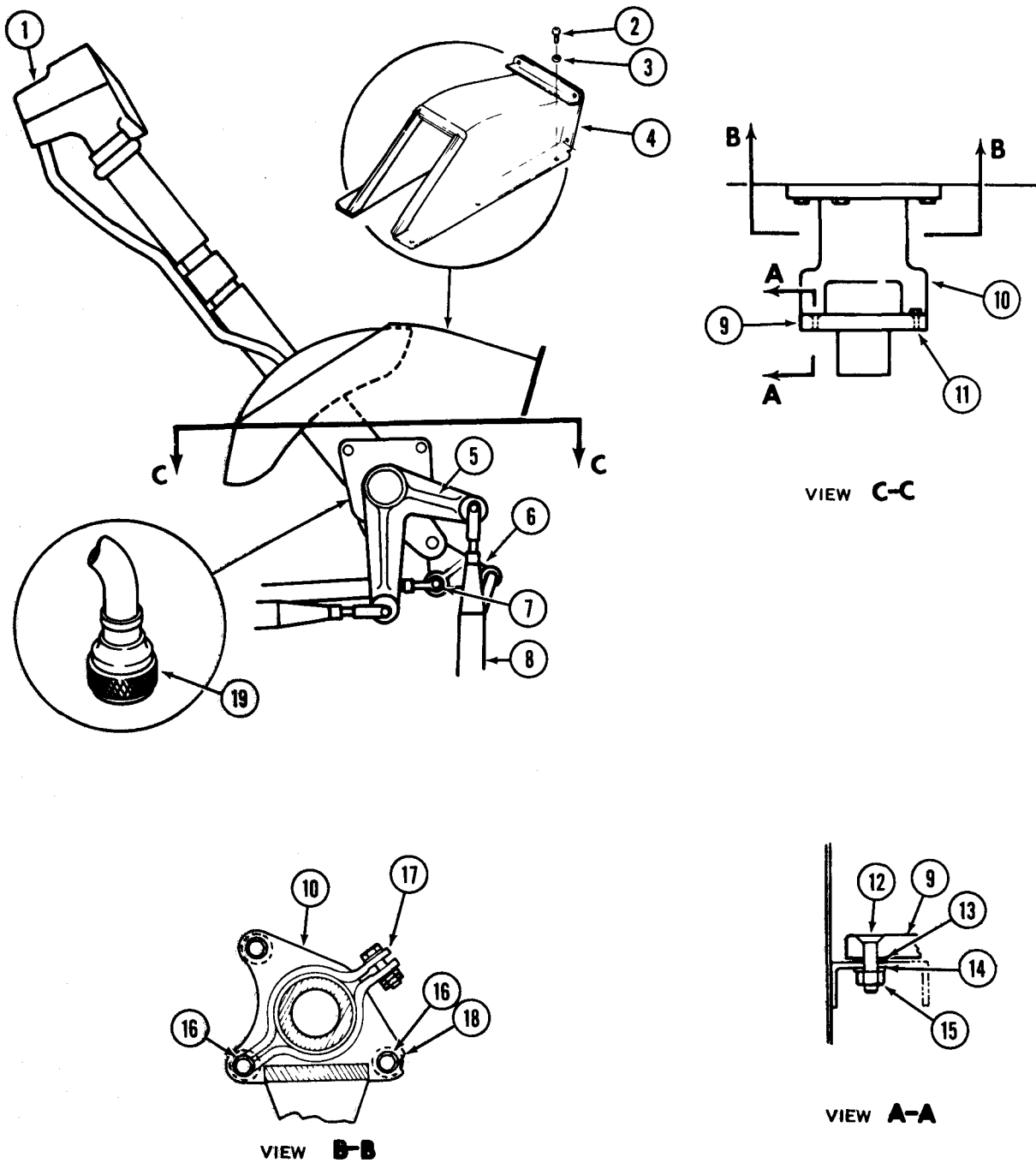

- |                           |                             |                     |
|---------------------------|-----------------------------|---------------------|
| 1. Collective stick       | 8. Collective tube assembly | 15. Nut             |
| 2. Screw                  | 9. Outboard support         | 16. Bolt            |
| 3. Washer                 | 10. Inboard support         | 17. Friction clamp  |
| 4. Cover                  | 11. Bolt                    | 18. Shim            |
| 5. Collective lever       | 12. Screw                   | 19. Cable connector |
| 6. Throttle lever         | 13. Shim                    |                     |
| 7. Throttle tube assembly | 14. Washer                  |                     |

209001-94B

Figure 11-2. Pilot Collective Stick Installation

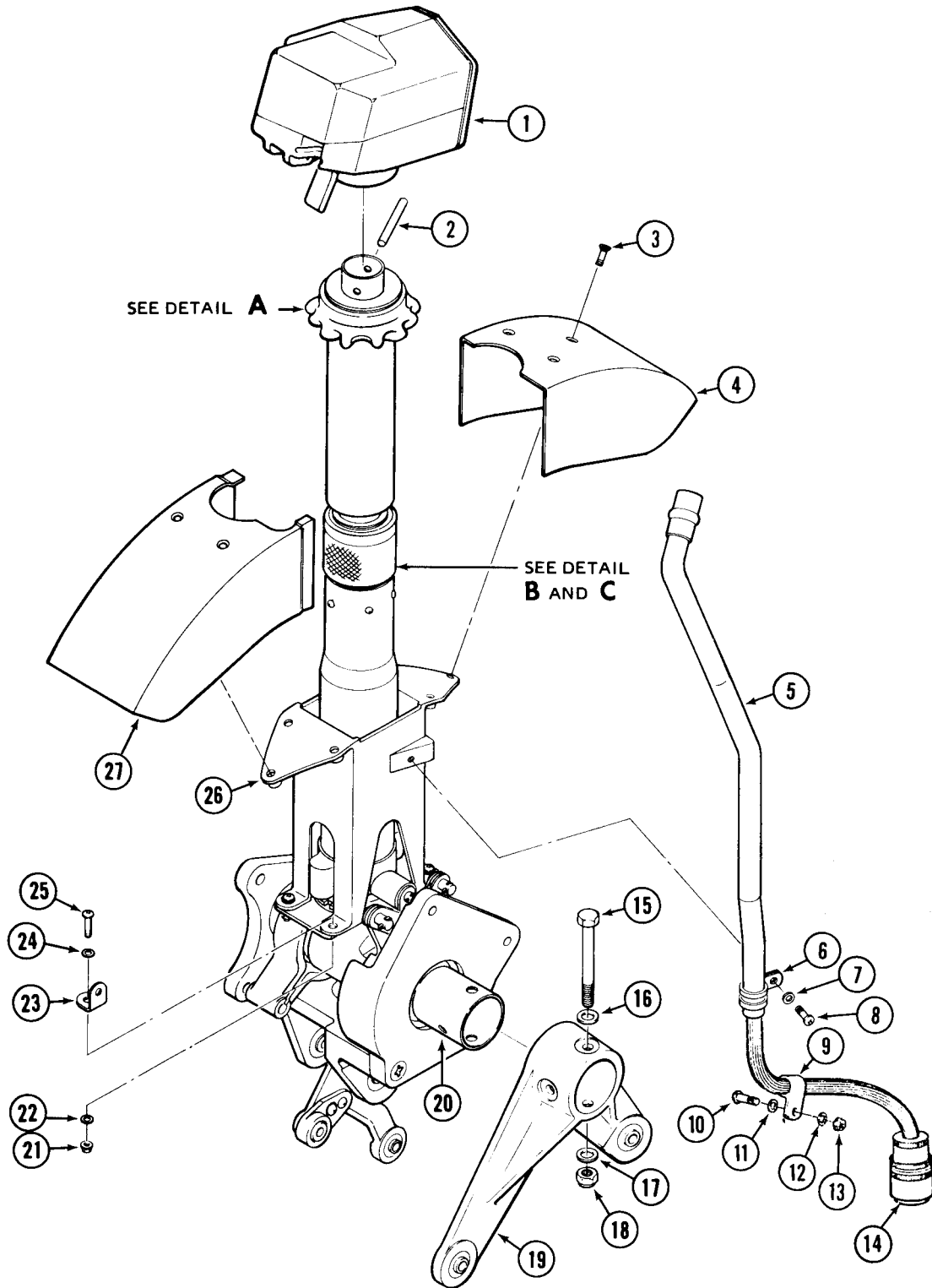

209001-159-1

Figure 11-3. Pilot Collective Stick Assembly (Sheet 1 of 4)

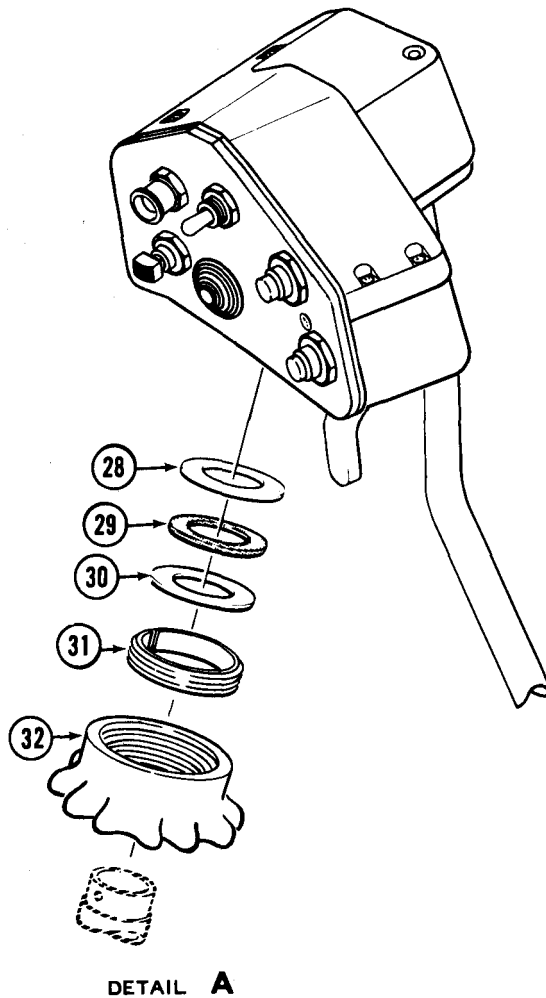

DETAIL A

- |                          |                           |
|--------------------------|---------------------------|
| 1. Control head          | 18. Nut                   |
| 2. Pin                   | 19. Lever assembly        |
| 3. Screw                 | 20. Elbow assembly        |
| 4. Boot, aft             | 21. Nut                   |
| 5. Electrical harness    | 22. Washer                |
| 6. Clamp                 | 23. Bracket               |
| 7. Washer                | 24. Washer                |
| 8. Screw                 | 25. Screw                 |
| 9. Clamp                 | 26. Boot support assembly |
| 10. Screw                | 27. Boot forward          |
| 11. Washer               | 28. Washer                |
| 12. Washer               | 29. Washer                |
| 13. Nut                  | 30. Washer                |
| 14. Electrical connector | 31. Friction screw        |
| 15. Bolt                 | 32. Nut                   |
| 16. Washer               |                           |
| 17. Washer               |                           |

209001-159-2

Figure 11-3. Pilot Collective Stick Assembly (Sheet 2 of 4)

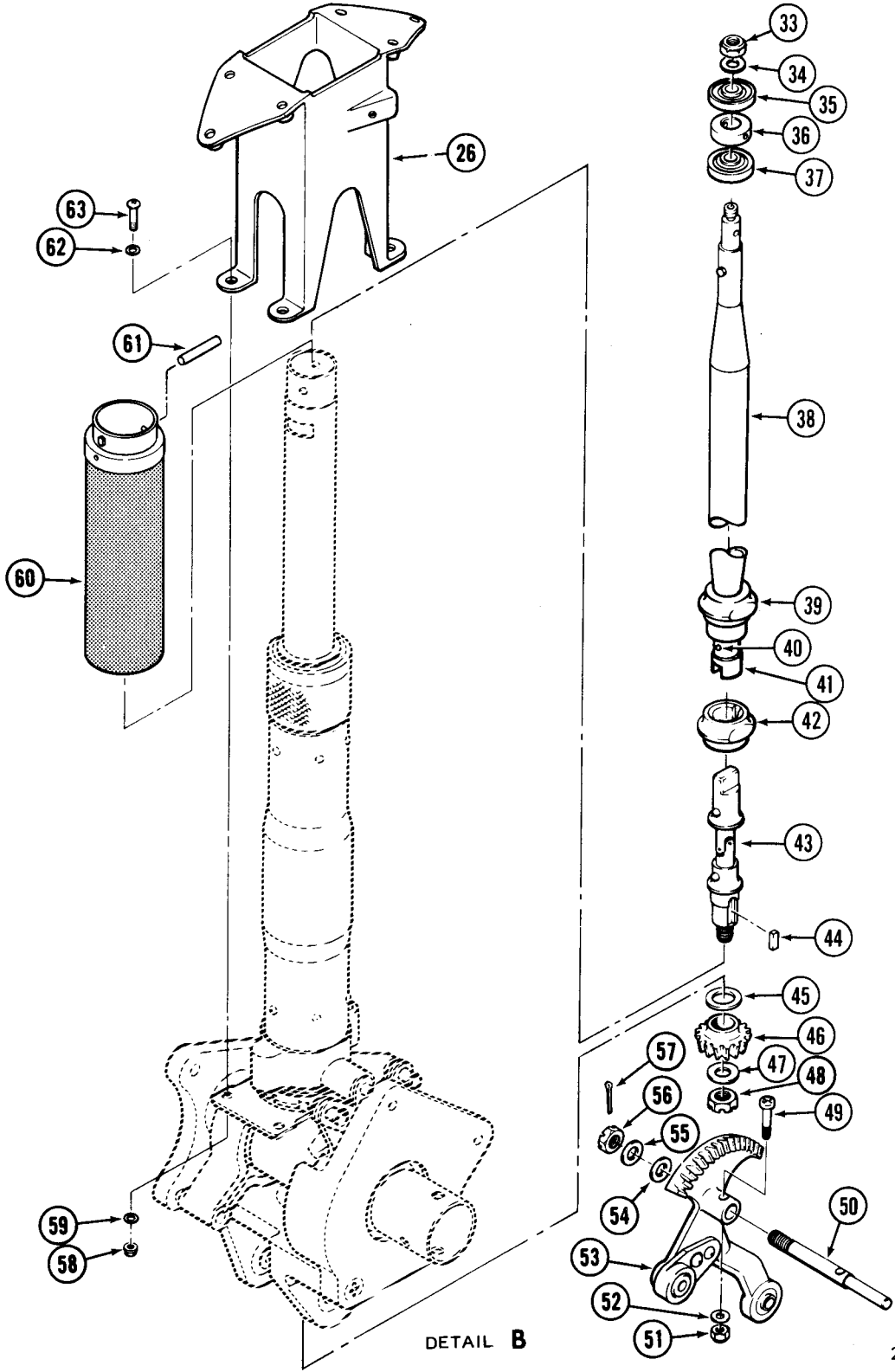

209001-159-3

Figure 11-3. Pilot Collective Stick Assembly (Sheet 3 of 4)

- 33. Nut
- 34. Washer
- 35. Bearing
- 36. Ring
- 37. Bearing
- 38. Throttle tube assembly
- 39. Guide
- 40. Rivet
- 41. Insert
- 42. Guide
- 43. Drive assembly
- 44. Key
- 45. Shim
- 46. Pinion gear
- 47. Washer
- 48. Nut
- 49. Bolt
- 50. Shaft
- 51. Washer
- 52. Nut
- 53. Throttle lever
- 54. Shim
- 55. Washer
- 56. Nut
- 57. Cotter pin
- 58. Nut
- 59. Washer
- 60. Grip
- 61. Pin
- 62. Washer
- 63. Screw
- 64. Retaining ring
- 65. Collective friction nut
- 66. Tube assembly
- 67. Bolt
- 68. Washer
- 69. Cotter pin
- 70. Nut
- 71. Pin
- 72. Cotter pin
- 73. Drag linkage
- 74. Plate
- 75. Washer
- 76. Nut

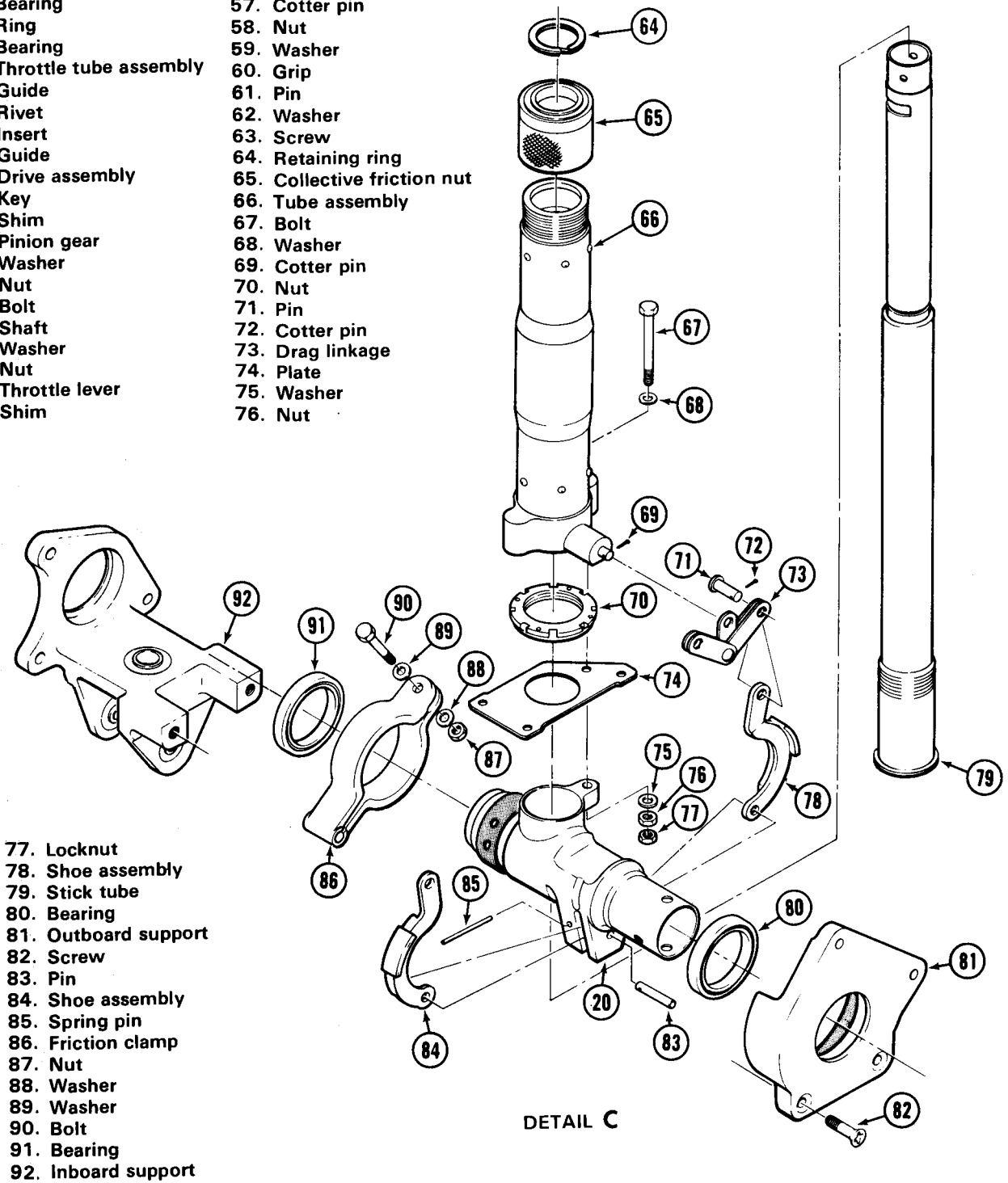

- 77. Locknut
- 78. Shoe assembly
- 79. Stick tube
- 80. Bearing
- 81. Outboard support
- 82. Screw
- 83. Pin
- 84. Shoe assembly
- 85. Spring pin
- 86. Friction clamp
- 87. Nut
- 88. Washer
- 89. Washer
- 90. Bolt
- 91. Bearing
- 92. Inboard support

209001-159-4

Figure 11-3. Pilot Collective Stick Assembly (Sheet 4 of 4)



d. Remove screw (10), washers (11 and 12), and nut (13) attaching electrical harness (5) to bracket (23). Remove screw (8) and washer (7) attaching electrical harness to boot support (26).

e. Remove pin (2) and lift control head (1) and electrical harness (5) from pilot collective stick.

f. Slide washers (28, 29 and 30), friction screw (31) and throttle friction nut (32) from stick tube (79).

g. Remove screw (25), washers (22 and 24), nut (21), and bracket (23).

h. Remove screw (63), washers (59 and 62), and nuts (58). Slide boot support assembly (26) from control stick.

i. Remove nut (51), washer (52), and bolt (49). Remove cotter pin (57), nut (56), washer (55), and shims (54). Measure thickness of shims and tag for installation at same location. Press shaft (50) from outboard support (81) and remove throttle lever assembly (53).

j. Remove nut (48), and washer (47), pinion gear (46), key (44) and shim (45) from drive assembly (43). Measure and record thickness of shim (45), Tag shim for installation in same location.

k. Rotate grip assembly (60) until pin (61) appears in small hole in grip assembly. Remove pin and slide grip assembly from stick tube (79).

l. Press drive assembly (43), guide (42), and throttle tube assembly (38) with attached hardware from stick tube (66). Separate drive assembly, guide and throttle tube assembly.

m. Remove nut (33), washer (34), bearings (35 and 37), and ring (36) from throttle tube assembly (38).

n. Remove two countersunk screws (82). Pull outboard support assembly (81) off elbow assembly (20). Pull inboard support assembly (92) off elbow assembly. Remove bearings (80 and 91) if bearings or supports (81 or 82) are unserviceable. Refer to TM 55-1500-204-25/1 .

o. Remove nut (87), washers (88 and 89), and bolt (90) from friction clamp (86). Slide clamp off elbow assembly (20).

p. Remove spring pin (85) and pin (83). Remove cotter pin (69), drag linkage (73, and shoe assemblies (78 and 84) from tube assembly (66) and elbow assembly (20). Separate drag linkage from shoe assemblies by removing cotter pin (72) and pins (71).

q. Remove two nuts (76 and 77), washers (68 and 75), and bolt (67). Remove retaining ring (64). Separate collective friction nut (65) from tube assembly (66) and remove both items from stick tube (79).

r. Cut safety wire and remove nut (70) and plate (74) from stick tube (79). Press stick tube out through base of elbow assembly (20).

## 11-12. INSPECTION - PILOT COLLECTIVE STICK.

### WARNING

Cleaning solvent is flammable and toxic. Provide adequate ventilation. Avoid prolonged breathing of solvent vapors and contact with skin or eyes.

a. Clean exposed surfaces by wiping with dry cloth dampened with solvent (C112). Do not allow solvent to enter bearings.

b. Visual inspection:

(1) All threaded areas for thread damage.

(2) Inspect all bearings in accordance with TM 55-1500-204-25/1 and for wear that exceeds **0.005** inch radial or **0.030** inch axial.

(3) All bolt holes for wear, maximum allowable 0.005 inch.

(4) All items for corrosion and mechanical damage. Maximum allowable **0.005** inch for corrosion and **0.010** inch for mechanical. Inspect for dents or distortions that would affect operation.

(5) All items for cracks or broken parts.

(6) All pins for grooving.

(7) Gears for broken or damaged teeth.

c. Fluorescent penetrant inspect to verify suspected flaws found during visual inspection of control head (1, figure 11-3), inboard support (92), outboard support (81) and elbow (20) in accordance with TM 43-0103.

d. Magnetic particle inspect to verify suspected flaw found during visual inspection of stick tube (79) in accordance with TM 43-0103.

**11-13. REPAIR OR REPLACEMENT - PILOT COLLECTIVE STICK (AVIM).**

a. Replace all damaged components unless covered by a specific repair.

b. Repair mechanical and corrosion damage as follows:

**The chemical film material is extremely dangerous. Contact with combustible materials will cause explosion or fire. Avoid contact with skin or eyes.**

**NOTE**

**Maximum allowable repair of mechanical and/or corrosion damage within distance of one diameter from edge of hole is 25 percent of area.**

(1) Use fine to medium grades of sandpaper (C102) or crocus cloth (C37). Do not use grinding wheels. Polish out mechanical damage only deep enough to remove traces of damage. Polish out corrosion damage to twice the depth of the deepest pit. Do not remove more material than necessary to blend repair smoothly into surrounding surface.

(2) Touch up repair area on aluminum parts with chemical film (C31) and primer (C88 or C91). Touch up repair area on steel parts with primer (C88 or C91).

c. Repair of throttle grip (1, figure 11 -4) is limited to replacement of bearings (2). Remove and replace bearings in accordance with TM 55-1 500-204-25/1. Position base upper bearing 1.42 inch from upper end of grip,

d. Repair of throttle tube is authorized at next higher maintenance level.

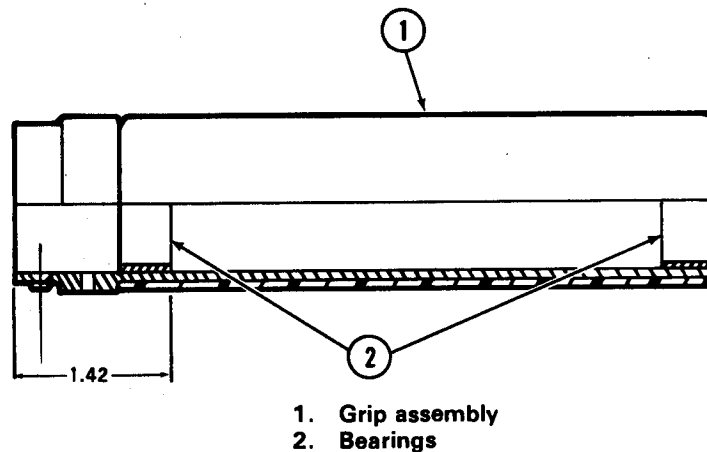

ALL DIMENSIONS ARE IN INCHES UNLESS OTHERWISE NOTED.

209001-96A

Figure 11-4. Bearing Installation - Pilot Throttle Grip

e. Replace damaged threaded inserts. in accordance with TM 55-1500-204-25/1 and as follows:

(1) Remove damaged helical coil insert with extraction tool or other suitable tool. Clear hole of all metal chips, Check threads with helical coil gage.

(2) Determine inserting tool of correct size. install helical coil insert until top of coil of insert is one-quarter to one-half turn below start of tapped threads. Break tang with long-nosed pliers or other suitable tool. Ensure that tang is removed from hole.

(3) After repair, ensure that threads will take required torque.

f. Replace friction linings as follows (figure 11-5):

(1) Drill rivets from worn linings and remove linings (2 and 4) from support (1) or elbow (5).



Cleaning solvent is flammable and toxic. Provide adequate ventilation. Avoid prolonged breathing of solvent vapors and contact with skin or eyes.

(2) Wipe bonding area on replacement linings (2 and 4), elbow (5), and support (1) with solvent (C112). Lightly sand the faying surfaces of linings, elbow, and support with 400 grit sandpaper (C102). Remove residue with solvent.

(3) Mix by weight, 100 parts A with 33 parts B (C14). Adhesive shall be used within **forty** minutes after mixing.

(4) Apply mixed adhesive to faying surface of linings (2 and 4), elbow (5), and support (1). Join detail parts while adhesive is tacky and within pot life time. Ensure proper alignment of parts and avoid trapping air within the bondlines. Clean off adhesive squeeze-out prior to curing. Cure for **24** hours at **70 TO 95** degrees F (**21 TO 35** degrees C) maximum strength obtained in 7 days, or using a properly regulated source of heat, cure bond at **160 TO 170** degrees F (**71 TO 77** degrees C) for **115** minutes with firm contact to 10 psi applied to parts.

(5) Drill two No. 40 holes in each support lining (2) and three No. 40 holes in elbow lining (4). Counter-sink holes 100 degrees to a sufficient depth to allow

rivet head to be installed **0.030** inch below surface of lining. Rivet linings (2 and 4) to elbow (5) and support (1) using MS20426AD3 or CR3212-04-07 rivets.

g. Replace bearing in throttle lever (2, figure 11-6) in accordance with TM 55-1500-204-25/1 and as follows:



**Repair is limited to one time. Replace lever if second repair is required.**

(1) Remove damaged bearing (1).

(2) Install new bearing.



**Stake depth must not exceed 0.010 inch.**

(3) Segment stake bearing in three places on both sides. Place new stake 60 degrees from old stake.

h. Replace bearings in collective lever as follows (figure 11-36):

**NOTE**

**This procedure is applicable to all 209-001-051-1 bearings.**

(1) Remove the staked lip from around one side of the old bearing by either filing or machining. Use care as not to damage ears of lever. Press old bearing from lever.

(2) Apply primer (C88 or C91) to outer race of new bearing and install new bearing in lever while primer is wet.

(3) Using anvil bearing staking tool set (T61) and suitable press, lay over the outer lip of the pre-grooved race onto the chamfer of the lever housing without touching the inner lip of the bearing or cause any cutting action on the outer lip.

(4) Ensure that after staking there is no more than **0.008** inch gap between the outer housing chamfer of lever and the staked lip on both side of bearing (figure 11-36).

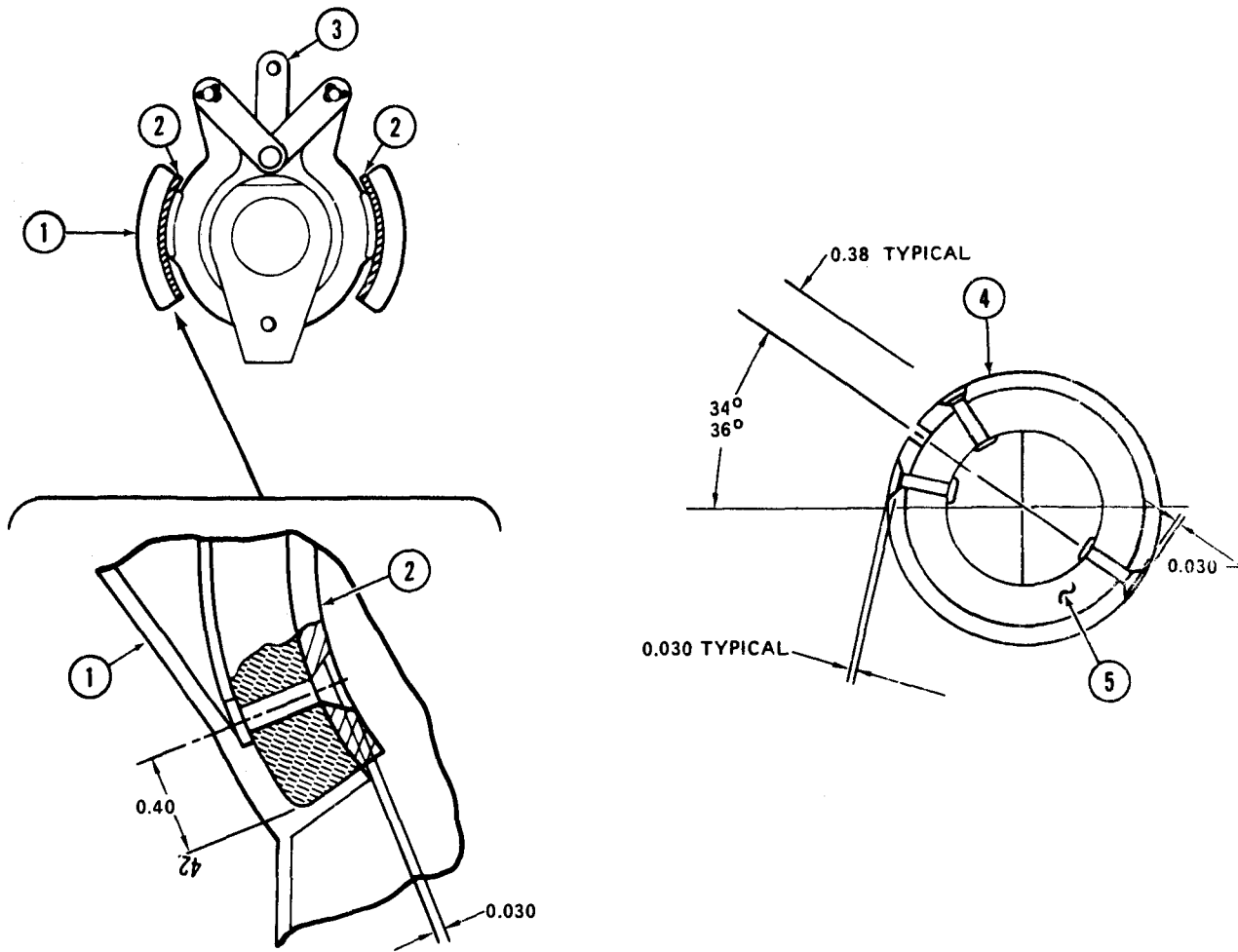

ALL DIMENSIONS ARE IN INCHES  
UNLESS OTHERWISE NOTED.

1. Outboard support
2. Support friction lining
3. Drag link assembly
4. Elbow friction lining
5. Elbow

209001-38A

Figure 11-5. Friction Lining Repair

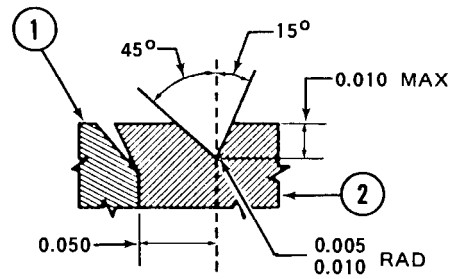

VIEW A A

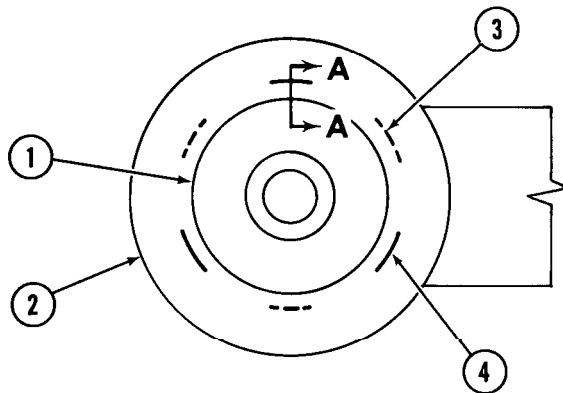

ALL DIMENSIONS ARE IN INCHES UNLESS OTHERWISE NOTED.

1. Bearing
2. Throttle lever
3. Old segment stake 120 degrees apart
4. New segment stake 120 degrees apart and 60 degrees from old segment stake

209001-99A

Figure 11-6. Throttle Lever Bearing Installation

i. Collective friction tube repair is limited to replacing the connector assembly (figure 11-7).

(1) Drill out six rivets (3) attaching connector assembly (1) to tube (2).

(2) Install new connector with base 1.73 inches from centerline of rivet holes.

(3) Drill six No. 40 holes in connector using tube as template. Rivet tube to connector.

j. Replace worn or damaged nutplates on boot support assembly in accordance with TM 55-1500-204-25/1.

#### 11-14. ASSEMBLY - PILOT COLLECTIVE STICK (AVIM).

a. Insert stick tube (79, figure 11-3) up through elbow assembly (20). Place flat spot, at base of stick tube, inboard.

#### NOTE

Use bolt (67) to maintain plate (74) and elbow assembly (20) alignment while tightening nut (70).

b. Install plate (74) and nut (70) on stick tube (79). Tighten nut and secure with lockwire (C138).

#### NOTE

Do not tighten nuts (76 and 77). Nuts will be tightened during collective friction adjustment.

c. Screw collective friction nut (65) on tube assembly (66). install both items and retaining ring (64) on stick tube. Align hole in base of tube assembly with hole in plate (74). Install bolt (67) with washers (68 and 75) through hole in tube assembly (66), plate (73), and elbow assembly (20). Install two nuts (76 and 77) on bolt (67).

#### NOTE

Pins (71) must be inserted from inboard side.

d. Attach drag link assembly (73) to shoe assemblies (78 and 84) with pins (71). Secure with cotter pins (72).

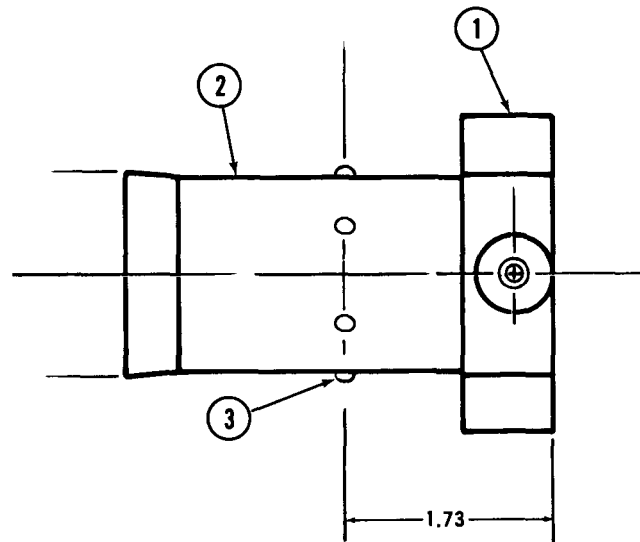

- 1. Connector assembly
- 2. Tube
- 3. Rivets, MS20470B3, six each

ALL DIMENSIONS ARE IN INCHES  
UNLESS OTHERWISE NOTED.

209001-100A

Figure 11-7. Collective Friction Tube Repairs

e. Install drag link assembly (73) on connector at base of tube assembly (66). Secure with cotter pin (69).

f. Place shoe assemblies (78 and 84) into slot in elbow assembly (20) and secure with pin (83). Secure pin (83) with spring pin (85).

#### NOTE

Do not tighten nut (87). Nut will be tightened during collective friction adjustment.

g. Install bolt (90, figure 11-3), washers (88 and 89) and nut (87) on clamp (86). Place clamp on inboard side of elbow assembly (20) with bolt up and aft.

h. Install inboard support assembly (92) and outboard support assembly (81) on elbow (20). Attach outboard support to inboard support with two countersunk screws (82).

**NOTE**

**Install bearings (80 and 91) in supports (80 and 91) if removed during disassembly.**

i. Install ring (34), bearings (35 and 37), washer (34) and nut (33) on throttle tube assembly (38). Align large hole in ring with hole in throttle tube.

j. Mate drive assembly (43), guide (42), and throttle tube assembly. Insert mated components into stick tube (79), drive assembly first.

k. Install grip assembly (60) on stick tube (79). Align large hole in grip assembly with large hole in ring (36) and throttle tube (38). Install pin (61) through grip, ring, and throttle tube.

l. Install shim (45) tagged during disassembly, key (44), pinion gear (46), washer (47) and nut (48) on drive assembly (43).

**NOTE**

**Check for smooth operation by rotating grip (60) through full travel.**

m. Install shim (54, figure 11-3), tagged during disassembly, and throttle lever assembly (53) on shaft (50). Position throttle lever with gear teeth facing small end of shaft.

n. With throttle grip (60) set at midtravel, match centerline of throttle lever gear (53) to pinion gear (46). Install shaft (50) into inboard support assembly (92) and secure with washer (55), nut (56), and cotter pin (57). Secure throttle lever to shaft bolt (49), washer (51), and nut (52).

o. Check mating between pinion gear (11, figure 11-8) and throttle lever gear (10). Surfaces of gear teeth should be flush within 0.020 inch. If pinion gear rides too high on lever gear, remove shim from point C and add to point B. If pinion gear rides too low, on lever gear, remove shim from point B and add to point C. Continue procedure until required dimension is obtained.

p. Adjust throttle breakaway force. Refer to paragraph 11-16.

**NOTE**

**Rotate throttle grip through full travel to ensure throttle lever is centered on pinion gear.**

q. Attach boot support assembly (26, figure 11-3) to plate (74) with screws, washers, and nuts (58). Position bracket (23) on left forward leg of boot support assembly, and secure with screw (25), washers (22 and 24) and nut (21).

r. Install throttle friction nut (32, figure 11-3), friction screws (31), washers (28 and 30), washer (31), and assembled control head on stick tube (79). Secure components to stick tube with pin (2).

s. Attach electrical cable (5) to boot support (25), with screw (8), washer (7), and clamp (6). Attach cable to bracket (22) with bolt (15), washers (11 and 12), nut (13), and clamp (9).

t. Install collective lever assembly (19) on elbow assembly (20) with arms down. Secure with bolts (15), washers (16 and 17) and nuts (18).

u. Attach forward and aft boots (4 and 27) to boot support (26) with six countersunk screws (3).

**11-15. INSTALLATION - PILOT COLLECTIVE STICK (AVIM).**

a. Install collective stick (1, figure 11-2) up through console.

b. Attach inboard support (10) to airframe with bolts (16) and washers. Lower bolt also passes through friction clamp (17). Shim (18) as required between support and airframe at upper right hand bolt.

c. Attach outboard support (9) to airframe with screw (12), bolt (11), washers (14), and nuts (15). Shim (13) as required between outboard support and airframe to a maximum gap of 0.003 inch.

d. Connect electrical cable (19).

e. Connect collective tube assembly (8) to collective lever (5) with bolts, washers, and nuts. Place one washer under bolt head and one washer under nut. Secure nut with cotter pin.

f. Connect throttle tube assembly (7) to throttle lever (6) with bolt inboard, washers, and nut. Place steel washer under bolt head and stainless steel washer under nut. Secure nut with cotter pin.

g. Adjust collective friction settings (paragraph 11-16).

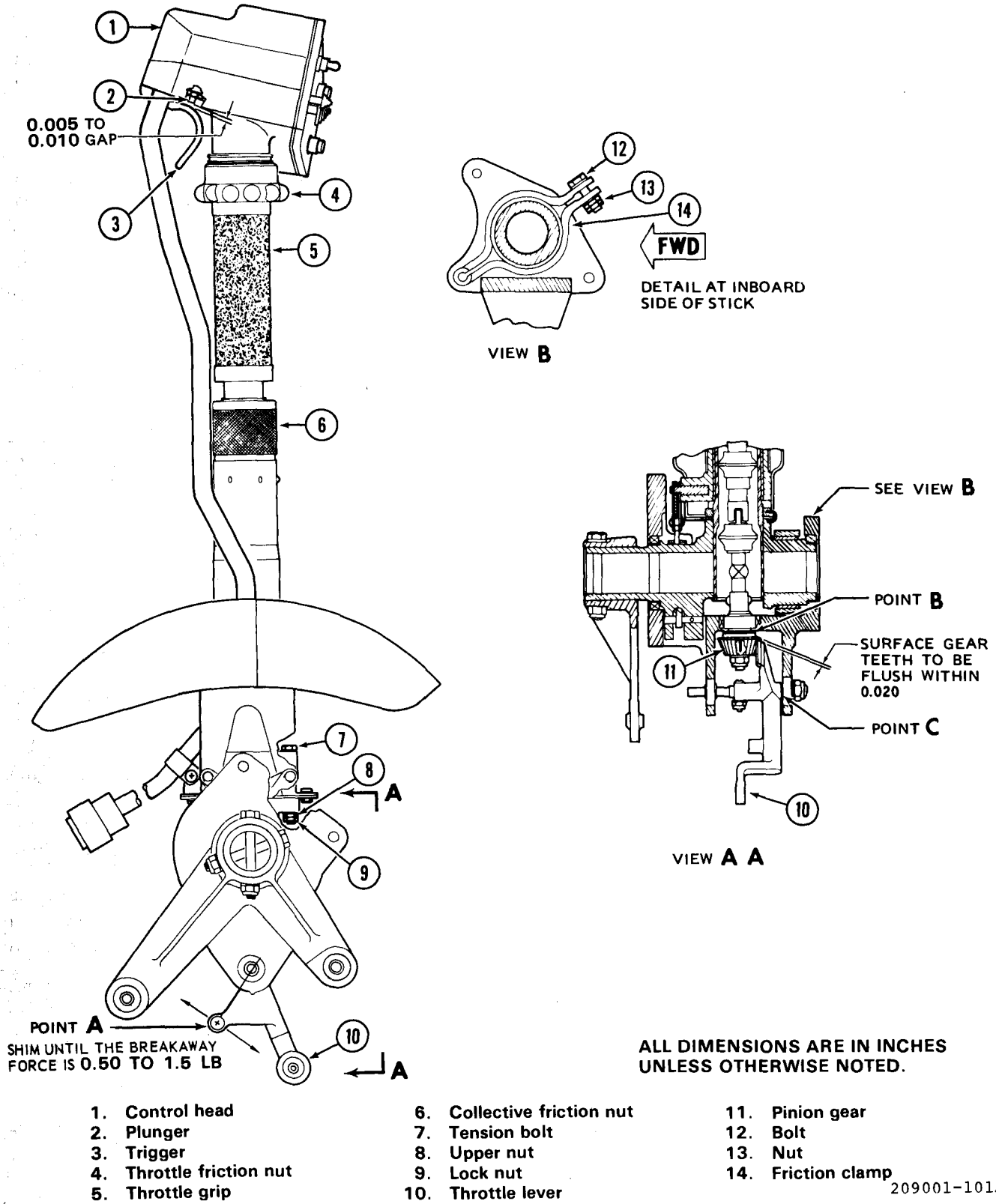

209001-101A

Figure 11-8. Pilot Collective Stick Adjustments



- h. Install access panels.
- i. Install collective stick cover (4).
- j. Check collective rigging (paragraph 11-7).
- k. Check power lever control rigging (paragraph 4-105).
- i. Perform maintenance test flight (TM 55-1520-236-MTF).

**11-16. ADJUSTMENT - PILOT COLLECTIVE STICK.**

- a. Adjust pilot collective stick friction to set minimum and maximum friction loads as follows: (figure 11-8).

(1) Apply hydraulic power with hydraulic test stand (S2).

**NOTE**

**if not using hydraulic power, open access door below left wing and disconnect control tube (8, figure 11 -1) from bellcrank (7) to allow movement of control stick.**

**(2)** Set minimum stick friction as follows:

**(a)** Place pilot collective stick at approximate midtravel position.

**(b)** Fully loosen collective friction nut (6, figure 11-8).

**(c)** Attach a force gage (fish scale) to grip (5) within 0.5 inch of center and perpendicular to stick grip (check for breakaway force to **9 TO 11** pounds).

**NOTE**

**if not using hydraulic power, breakaway force should be 11 to 13 pounds.**

**(d)** if breakaway force is not within limits, remove cover and adjust bolt (12) and nut (13) on friction clamp (14) to obtain breakaway force within limits.

**(e)** If breakaway force cannot be adjusted by use of bolt (12) and nut (13) an friction clamp (14), remove pilots collective stick and check the friction liner on the elbow (4, figure 11-5), for glazing, broken wires and unevenness.



**Maximum stick friction must be set within limits to ensure that the gunner**

**collective stick can be moved when the pilot friction nut (6) is fully tightened.**

**NOTE**

IPs collective friction may be set at 4 to 6 lbs. on training aircraft only (TH-1S and TAH-1S).

**(3)** Set maximum stick friction as follows:

**(a)** Place pilot collective stick at approximate midtravel position.

**(b)** Loosen nuts (8 and 9) on tension bolt (7).

**(c)** Attach a force gage (fish scale) to stick grip within 0.5 inch of center and perpendicular to stick grip. Check for breakaway force of **14 TO 16** pounds. if breakaway force is not within limits, adjust friction nut (6) to obtain breakaway force within limits.

**(d)** Tighten upper nut (8, figure 11-8) on tension bolt (7) fingertight and secure with lock nut (9). Recheck breakaway force to ensure that it is within limits.

**(e)** Disconnect hydraulic power ground test unit.

**(f)** Check for security and safetying of collective control stick components.

**(g)** Ensure that gunner collective stick can be moved when pilot collective friction nut (6) is fully tightened.

**b.** Adjust throttle breakaway force as follows:

**NOTE**

**Steps (1, (2), (7), and (8) will be followed if collective stick is installed in helicopter.**

**(1)** Remove left side access panel.

**(2)** Disconnect throttle tube assembly from throttle lever (10, figure 11-8).

**(3)** Set throttle friction nut (4) to minimum friction setting.

**(4)** Measure breakaway force at point A on lever (10). Use a spring scale to apply force in direction illustrated by arrows.

**NOTE**

**It is necessary to equally add or remove laminations of shims at points B and C because tooth surfaces on pinion (11) and lever (10) must remain flush within 0.020 inch.**

**(5)** Add or remove shims at points B and C to obtain a breakaway force of **0.50 TO 1.50** pounds. Refer to paragraph 11-11 for shim removal and paragraph 11-14 for shim installation.

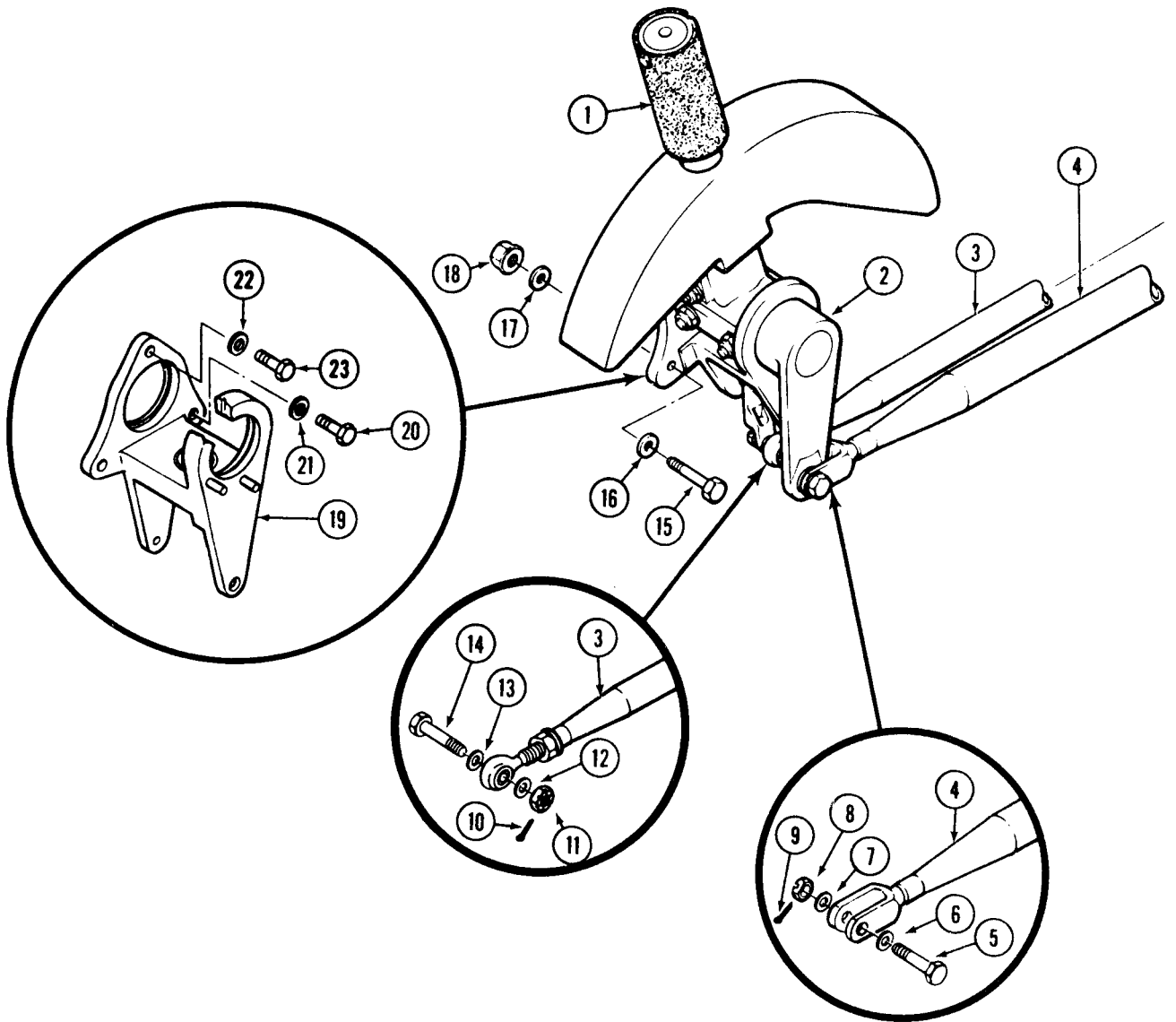

209001-105A

- |                               |                            |                      |
|-------------------------------|----------------------------|----------------------|
| 1. Collective stick           | 8. Nut                     | 15. Bolt             |
| 2. Collective lever           | 9. Cotter pin              | 16. Washer           |
| 3. Tube assembly (throttle)   | 10. Cotter pin             | 17. Washer           |
| 4. Tube assembly (collective) | 11. Nut                    | 18. Nut              |
| 5. Bolt                       | 12. Stainless steel washer | 19. Support assembly |
| 6. Washer                     | 13. Washer                 | 20. Bolt             |
| 7. Washer                     | 14. Bolt                   | 21. Washer           |
|                               |                            | 22. Washer           |
|                               |                            | 23. Bolt             |

Figure 11-9. Gunner Collective Stick Installation



(6) Repeat step (4) to determine whether breakaway force is now within tolerance. If necessary, repeat shimming procedure.

(7) Connect throttle tube assembly to throttle lever (10) (paragraph 11-15).

(8) Install access covers.

**11-17. GUNNER COLLECTIVE STICK.**

**11-18. DESCRIPTION - GUNNER COLLECTIVE STICK.**

The collective control mounted in the gunner left side console is a dual control for occasional or emergency use. It has only the essential functions of collective pitch and throttle control. There are no electrical switches. Because of the difference in length of the pilot and gunner collective stick more force (1.1 to 1 ratio) is required to move gunner collective stick than is required to move pilot collective stick.

**Premaintenance Requirements for Gunner Collective Stick**

Conditions	Requirements
Model	AH-1S
Part No. or Serial No.	All
Special Tools	None
Test Equipment	None
Support Equipment	None
Minimum Personnel Required	One
Consumable Materials	(C112), (C137)
Special Environmental Conditions	None

**11-19. REMOVAL - GUNNER COLLECTIVE STICK (AVIM).**

a. Remove screw-mounted panel from left side of fuselage above ammunition compartment for access to lower end of control stick.

b. Disconnect collective system tube assembly (4, figure 11-9) from collective lever (2), and throttle system tube assembly (3) from throttle lever of control stick.

c. Remove bolts (15 and 20), washers (16, 17, and 21), and one nut (18) that attach support assembly (19) to airframe. Loosen bolt (23).

**NOTE**

**Bolt (23) and washer (22) will stay with collective stick assembly.**

d. Remove collective stick by lowering it down through console.

**11-20. DISASSEMBLY - GUNNER COLLECTIVE STICK (AVIM).**

a. Remove nut (40, figure 11-10), screw (44), and washers that attach throttle lever (42) to shaft (39). Remove cotter pin (37), nut (36), and washer (35). Press shaft from support assembly (32) and remove throttle lever and shims (38). Measure and record thickness of shims (38). Tag shims for installation in same location.

b. Remove nut (46) and washer (47), pinion gear (48), key (13), and shim (49) from drive assembly (12). Measure and record thickness of shim (49). Tag shim for installation in same location.

c. Remove nut (7), screw (1), and washers (2, 3, 5, and 6) that attach throttle grip (26) to throttle tube (9). Remove throttle grip (26) and ring (4).

d. Remove screws (23) that attach boot (24) to elbow (18). Remove boot.

e. Remove nuts (15), bolts (21), and washers (14 and 22) from elbow (18). Remove control stick (8), throttle tube (9), guides (10 and 11) and drive assembly (12) from elbow.

f. Remove nuts (16), bolts (20), and washers (17 and 19) that attach collective lever (27) to elbow. Separate collective lever (27) from elbow (18) and elbow from support assembly (32). Remove bolt (29) and washer (30) from support assembly.

g. Remove bearings (28, 31, 33, 34, 45 and 50) if bearings or support (32) or lever (27) are unserviceable. Refer to TM 55-1500-204-25/1.

## 11-21. INSPECTION - GUNNER COLLECTIVE STICK.



Cleaning solvent is flammable and toxic. Provide adequate ventilation. Avoid prolonged breathing of solvent vapors and contact with skin or eyes.



Do not allow solvent to enter bearings.

a. Clean exposed surfaces by wiping with dry cloth dampened with solvent (C112).

b. Visual inspection.

(1) AH threaded areas (figure 11-10) for thread damage.

(2) All bearings in accordance with TM 55-1500-204-25/1 and for wear that exceeds 0.005 inch radial and 0.030 inch axial.

(3) All bolt holes for wear. Maximum allowable wear is 0.005 inch.

(4) All items for corrosion and mechanical damage. Maximum allowable 0.005 inch for corrosion and 0.010 for mechanical. Inspect for dents or distortions that would affect operation.

(5) All items for cracks or broken parts.

(6) All pins for grooving.

(7) Gears for broken teeth.

c. Fluorescent penetrant inspect to verify Suspected flaws found during visual inspection of elbow (18), collective lever (27), and support assembly (32) in accordance with TM 43-0103.

d. Magnetic particle inspect to verify suspected flaws found during visual inspection of control stick (8) in accordance with TM 43-0103.

## 11-22. REPAIR OR REPLACEMENT - GUNNER COLLECTIVE STICK (AVIM).

a. Replace all damaged components unless covered by a specific repair.

b. Repair mechanical and corrosion damage (paragraph 11-1 3).

c. Replace unserviceable bearing (25) in throttle grip (26, figure 11-10). Remove and replace bearing in accordance with TM 55-1500-204-25/1.

d. Replace unserviceable bearing (50) in collective lever (27) (paragraph 11-12).

## 11-23. ASSEMBLY - GUNNER COLLECTIVE STICK (AVIM).

### NOTE

**If bearings (28, 31, 33, 34, 45, or 50, figure 11-11) were removed from support assembly (32), or collective lever (27), install bearings.**

a. Install and tape bolt (29) and washer (30) in top hole of support assembly (32). Place elbow (18) into support with slot towards bolt (29). Align elbow with bearings (28 and 31) and press collective lever (27) into elbow from side opposite slot. Align bolt holes in collective lever with bolt holes in elbow and install bolts (20), washers (17 and 19) and nuts (16).

b. Assemble drive assembly (12), guide (10 and 11), and throttle tube (9). Place assembled components into control stick (8). Place control stick into elbow (18). Align slots in control stick with bolt holes in elbow. Install bolts (21), washers (14 and 22) and nuts (15).

c. Install boot (24) on elbow (18) with screws. Lockwire (C137) screws together. Place ring (4) on throttle tube (9). Place throttle grip (5) on control stick (8). Align holes in grip, ring, and throttle tube. Install screw (1), washers (2, 3, 5, and 6) and nut (7).

### NOTE

**Vary quantity of washers (2, 3, 5, and 6) under screw head to maintain 0.20 to 0.22 inch projection through nut (7).**

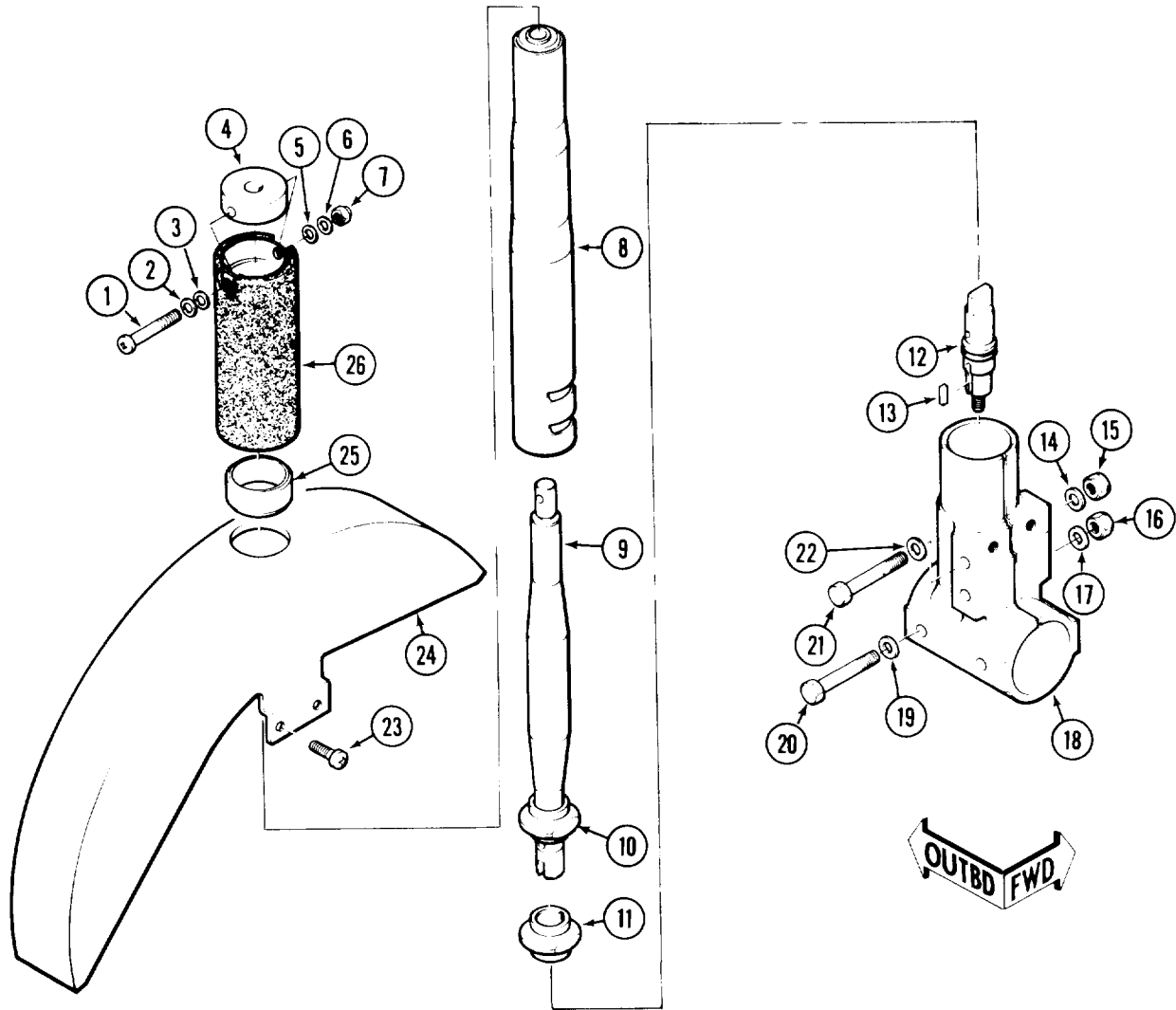

- 1. Screw
- 2. Washer
- 3. Washer
- 4. Ring
- 5. Washer
- 6. Washer
- 7. Nut
- 8. Control stick
- 9. Throttle tube assembly
- 10. Guide
- 11. Guide
- 12. Drive assembly
- 13. Key

- 14. Washer
- 15. Nut
- 16. Nut
- 17. Washer
- 18. Elbow
- 19. Washer
- 20. Bolt
- 21. Bolt
- 22. Washer
- 23. Screw
- 24. Boot
- 25. Bearing
- 26. Throttle grip

209001-160-1

Figure 11-10. Gunner Collective Stick Assembly (Sheet 1 of 2)

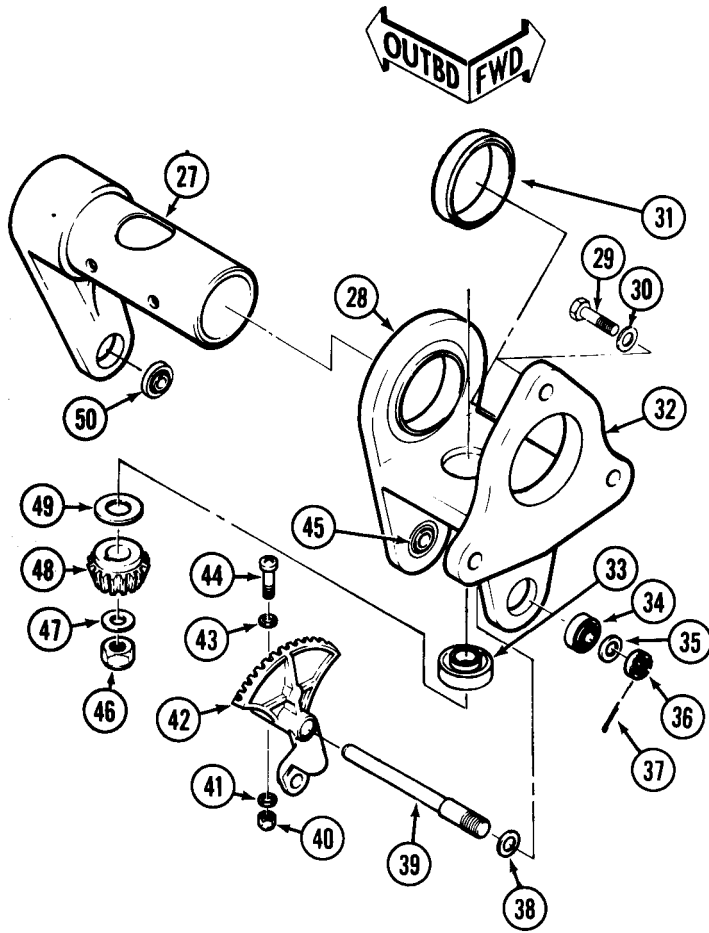

- 27. Collective lever
- 28. Bearing
- 29. Bolt
- 30. Washer
- 31. Bearing
- 32. Support
- 33. Bearing
- 34. Bearing
- 35. Washer
- 36. Nut
- 37. Cotter pin
- 38. Shim

- 39. Shaft
- 40. Nut
- 41. Washer
- 42. Throttle lever
- 43. Washer
- 44. Screw
- 45. Bearing
- 46. Nut
- 47. Washer
- 48. Pinion gear
- 49. Shim
- 50. Bearing

209001-160-2

Figure 11-10. Gunner Collective Stick Assembly (Sheet 2 of 2)



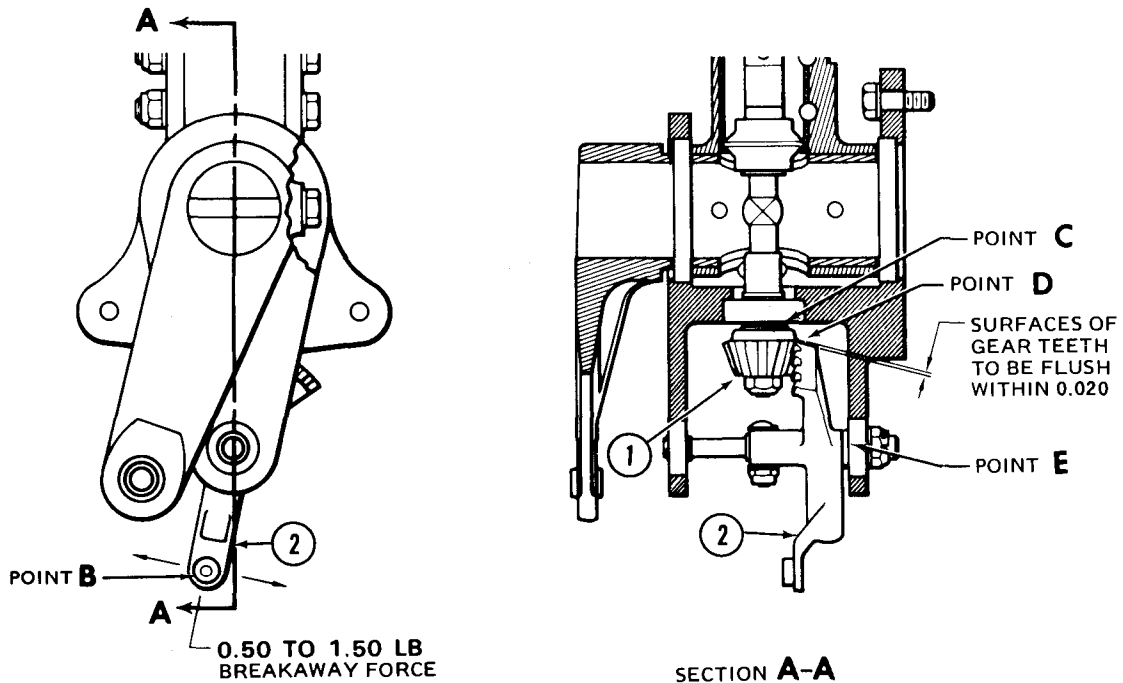

- 1. Pinion gear
- 2. Throttle lever

ALL DIMENSIONS ARE IN INCHES UNLESS OTHERWISE NOTED.

209001-103A

Figure 11-11. Gunner Collective Stick Adjustment

d. Install shim (49), tagged during disassembly, key (13), pinion gear (48), washer (47), and nut (46) on drive assembly (12).

**NOTE**

**Check for smooth operation by rotating grips (26) through full travel.**

e. Install shim (38), tagged during disassembly, and throttle lever assembly on shaft (39). Position throttle lever with gear teeth facing small end of shaft.

f. Install shaft (39) into support assembly and secure with washer (35), nut (36), and cotter pin (37). Secure throttle lever to shaft with screw (44), washer (41 and 43), and nut (40).

g. Check mating between pinion gear (1, figure 11-11) and throttle lever gear (2). Surfaces of gear teeth should be flush within **0.020** inch. If pinion gear rides too high on lever gear, remove shim from point E and add to point C. If pinion gear rides too low

on lever gear, remove shim from point C and add to point E. Continue procedure until required dimension is obtained.

h. Adjust throttle breakaway force (paragraph 11-25).

i. Wire throttle lever (2) to support (3) to maintain position during subsequent handling.

**11-24. INSTALLATION - GUNNER COLLECTIVE STICK (AVIM).**

a. Install collective stick (1, figure 11-9) up through console and attach support assembly (19) to airframe with three bolts (15, 20, and 23), washers (16, 17, 21, and 22) and one nut (18).

b. Connect throttle tube assembly (3) to throttle lever with bolt (14), head inboard, washers (12 and 13), and nut (11). Place steel washer (13) under bolt head and stainless steel washer (12) under nut. Secure nut with cotter pin (10).

c. Connect collective tube assembly (4) to collective lever (1) with bolts (5), washers (6 and 7) and nut (8). Place one washer under nut, and one washer under bolt head. Secure nut with cotter pin (9).

d. Remove wire (paragraph 11-23).

**11-25. ADJUSTMENT - GUNNER COLLECTIVE STICK.**

**NOTE**

**Steps a., b., f., and g., will be followed if collective stick is installed in aircraft.**

a. Remove left side access panel (paragraph 2-59).

b. Disconnect throttle tube assembly from throttle lever (2, figure 11-11).

c. Measure breakaway force at point B on throttle lever (2). Use a spring scale to apply force in direction illustrated by arrows on lever.

**NOTE**

**If necessary, equally add or remove laminations of shims at points C and E because tooth surfaces on pinion (1) and lever (2) must remain flush within 0.020 inch at point D.**

d. Add or remove shims at points C and E to obtain a breakaway force of **0.50 TO 1.50** pounds. Refer to paragraph 11-20, a. and b., for shim removal and paragraph 11-23, d., e., and f., for shim installation.

e. Repeat step d., to determine whether breakaway force is now within tolerance. If necessary, repeat shimming procedure.

f. Connect throttle tube assembly to throttle lever (2) (paragraph 11-24, b.).

g. Install left side access panel (paragraph 2-59).

**11-26. CYCLIC SYSTEM.**

**11-27. DESCRIPTION - CYCLIC SYSTEM.**

The main rotor cyclic controls consist of interconnected control sticks in pilot and gunner compartments, and two separate systems of linkage to the swashplate. Each of the cyclic systems includes a dual hydraulic cylinder, a servo-actuator and a

transducer of the SCAS (Stability and Control Augmentation System) and a force trim magnetic brake connected to control linkage through a spring-loaded force gradient assembly. The fore-and-aft cyclic controls extend aft from the control sticks to a jackshaft, then downward at right side of fuselage, then aft below the forward fuel cell, then upward to the hydraulic cylinder which is connected on the right forward horn of the swashplate (figure 11-12). The lateral cyclic controls are interconnected between control sticks at right side of the fuselage, then extend aft and to left side, then downward and aft below the fuel cell, then upward to the hydraulic cylinder which is connected on the left forward horn of the swashplate (figure 11-13).

**Premaintenance Requirements for Cyclic Control System**

Conditions	Requirements
Model	AH-1S
Part No. or Serial No.	All
Special Tools	(T46)
Test Equipment	None
Support Equipment	(S2)
Minimum Personnel Required	Two
Consumable Materials	(C43), (C138)
Special Environmental Conditions	None

**11-28. INSPECTION - CYCLIC SYSTEM.**

a. Inspect control system in place for secure installation, damage, and freedom of operation through full range of travel (figures 11-12 and 11-13).



**Insure adequate clearance exists between the air distribution ducts and the control tubes of the cyclic system to allow free movement over the full range of tubes.**

b. If required; remove components for detailed inspection. Refer to paragraphs 11-40 and 11-169 for

damage limits on bellcranks and tube assemblies. Refer to paragraph 7-63 for damage limits on hydraulic cylinder assemblies.

#### 11-29. RIGGING — CYCLIC SYSTEM (Preferred Method).

a. Accomplish rigging with hydraulic power unless otherwise stated.

b. Install all components of the cyclic control system with the following exceptions:

(1) Leave hydraulic cylinders (4, figure 11-12, and 6, figure 11-13) disconnected from swashplate. Also, leave the elevator control tube (3, figure 11-12) and spring (2) disconnected.

(2) Leave control tube (7) disconnected from bellcrank (8) but connect to hydraulic cylinder valve lever.

(3) Leave control tube (8, figure 11-13) disconnected from bellcrank (9) but connect to hydraulic cylinder valve lever.

(4) Leave control tube (16, figure 11-12) and transducer (13) disconnected from bellcrank (11).

(5) Leave control tube (11, figure 11-13) and transducer (15) disconnected from bellcrank (13).

c. Check and adjust cyclic stick friction (paragraph 11-37).

d. Hold pilots cyclic stick full right.

e. Adjust control tube (11) to 14.36 inches between bolt hole centers and connect to bellcrank (13).

f. Check that aft arm of bellcrank (9) is raised to its highest travel without touching aft stop bolt (10). If necessary, adjust stop bolt to clear.

g. Push control tube (8) upward to bottom out piston in top of hydraulic cylinder (6) and hold lever of valve (7) at top of travel. Adjust control tube (8) length to fit on bellcrank with control stick full right, then shorten two full turns and connect tube to bellcrank. Check exposed threads to ensure that not more than 1.25 inches of thread is exposed (figure 11-13, detail A). If necessary, adjust length of control tube (11) and repeat adjustment procedure for tube (8). Ensure that

there is not more than one inch exposed threads on control tube (11) (figure 11-12, detail C). Check bolt that attaches control tube (8) to hydraulic cylinder valve (7), torque bolt finger tight and install cotter pin. The bolt must turn freely.

### CAUTION

Do not interchange control tube (7, figure 11-12) and control tube (8, figure 11-13).

h. Adjust stop bolts (10, figure 11-13) for 0.005 to 0.015 inch clearance with bellcrank at full right and full left control positions.

i. Install rigging fixture (T46) on pilots cyclic control stick

(1) Remove four screws, washers, and nuts from holes in pilots floor outboard of stick support.

(2) Open clamp of rigging fixture (T46) and place over stick with open end of damp aft. Engage pins in mounting holes.

j. Clamp cyclic stick in aft hole "A" of rigging fixture (T46). Hold bellcrank (8, figure 11-12) against fixed stop (9). Adjust control tube (16) and connect to bellcrank (11).

k. Push Control tube (7) upward to bottom out piston in top of hydraulic cylinder (4) and hold lever of valve (6) at top of travel. Adjust control tube (7) length to fit on bellcrank (8), then shorten two full turns and connect to bellcrank. Check exposed threads on control tube (7) to ensure that not more than one inch of thread is exposed (figure 11-12, detail B). Check bolt that attaches control tube (7) to hydraulic cylinder valve (6), torque bolt finger tight and install cotter pin. The bolt must turn freely.

l. Clamp cyclic control stick in center hole "N" of rigging fixture (T46).

m. Fabricate a work aid as shown in figure 11-14 or use an 18 inch scale as a measuring instrument. Set both swashplate horns to 12.92 inches, measured from transmission flange to center edge of bolt holes. Keep right horn at 12.82 inches  $\pm 0.06$  and set left horn to 12.52 inches  $\pm 0.06$  (figure 11-15).

**NOTE**

An alternate method of measuring the swashplate in case it bottoms out on the swashplate support after the rigging has been completed is to measure from the bottom of the transmission top case to the bottom edge of the bolt holes using the following dimension, 13.63 ± 0.06 inches for the right horn and 13.33 ± 0.06 inches for the left hand horn.

n. Remove lockwire from retaining nut (26, figure 11-12) and loosen nut.

o. Adjust rod end (24) of extension tubs (27) to fit right swashplate horn at its measured position. Do not attach hydraulic cylinder to swashplate at this time.

p. Torque nut (26) 450 TO 600 inch-pounds. Lockwire nut to lock (25) with lockwire (C138).

Position boot (29) on cylinder (4) and extension tube as shown in figure 11-12, detail D. Top of boot should be 13.70 inches from bottom of locknut on rod end. Tighten clamps (28) with boot in this position.

r. Remove lockwire from retaining nut (33, figure 11-13) and loosen nut.

s. Adjust rod end (31) of extension tube to fit left swashplate horn at its measured position. Torque retaining nut (33) 480 TO 600 inch-pounds and lockwire with wire (C138).

**NOTE**

Any rod end bearing which exceeds the 0.80 inch maximum or 2.50 inch maximum dimensions should be readjusted within these limits. Rod ends with insufficient exposed threads to permit lock (32) engagement should also be readjusted. Final rigging adjustment should be at the interface of the extension tubs and hydraulic cylinder assembly.

t. Position bottom of boot (4) in groove provided on base (5). Position top of boot (4) on extension tubs so that there is a distance of 15.16 inches from top of boot to bottom of locknut on rod end. Tighten clamp(3) with boot in this position (figure 11-13, detail B).

u. Attach hydraulic cylinders adjusted in the two preceding steps to the swashplate. Connect spring (2, figure 11-12) to bracket at outer side of right horn.

v. Remove rigging fixture (T46) from control stick.

w. Hold control stick full forward. Position transducer (13) in retracted position, adjust rod end and connect on inboard side of bellcrank. Use large safety washer under screw head and aluminum alloy washers under nut and between rod end and bellcrank. Move control stick full aft and check that transducer does not bottom out.

x. Hold cyclic full forward. Hold arm on magnetic brake (17) full aft. Adjust rod end of force gradient (14) and connect to arm on jackshaft (15). If there is not enough adjustment in force gradient (14), rotate the arm of the magnetic brake (17) one serration counter clockwise.

y. Hold cyclic stick full right. Adjust and connect lateral SCAS transducer (15, figure 11-13) in retracted position on inboard side of bellcrank (13). Install safety washer and aluminum alloy washers in same manner described in step w. above. Move cyclic stick full left and check that transducer does not bottom out.

z. Hold cyclic stick at center position. Hold arm of magnetic brake (27) square to beam on which brake is mounted. Adjust force gradient rod end bearing (20) and connection bolt at underside of forward arm of bellcrank (19).

aa. Check complete cyclic controls system for security and safetying of components.

ab. Check operation by moving cyclic controls through full throw and ensure that there is no binding or interference.

ac. Rig and connect synchronized elevator controls (paragraph 11-138).

ad. Perform maintenance test flight (TM 55-1520-236-MTF).

**11-29.1. RIGGING — CYCLIC SYSTEM (ALTERNATE METHOD).**

a. Accomplish rigging without hydraulic power unless otherwise stated.

b. Install all components of the cyclic control system with the following exceptions:

(1) Leave hydraulic cylinders (4, figure 11-12) and (6, figure 11-13) disconnected from swashplate. Also, leave the elevator tube assembly (3, figure 11-12) and spring (2) disconnected.

(2) Leave tube assembly (7) disconnected from bellcrank (8) but connect to hydraulic cylinder valve lever (6).

(3) Leave tube assembly (8, figure 11-13) disconnected from bellcrank (9) but connect to hydraulic cylinder valve lever (7).

(4) Leave tube assembly (16, figure 11-12) and transducer (13) disconnected from bellcrank (11).

(5) Leave tube assembly (11, figure 11-13) and transducer (15) disconnected from bellcrank (13).

c. Check and adjust cyclic stick friction (paragraph 11-37).

d. Hold pilot cyclic control stick full right.

e. Adjust control tube (11, figure 11-13) to 14.36 inches between bolt hole centers and connect to bellcrank (13).

f. Check that aft arm of bellcrank (9) is raised to its highest travel without touching aft stop bolt (10). If necessary, adjust stop bolt to clear.

### CAUTION

Do not interchange tube (7, figure 11-12), and tube (8, figure 11-13).

g. Push tube assembly (8) upward to bottom out piston in top of hydraulic cylinder (6) and hold lever of valve (7) at top of travel. (See Detail A, figure 11-13). Adjust tube assembly (8) length to fit on bellcrank (9) with control stick full right, then shorten two full turns and connect tube to bellcrank. Check exposed threads to ensure that not more than 1.25 inches of thread is exposed. See Detail A. If necessary, adjust length of tube assembly (11) and repeat adjustment procedure for tube (8). Ensure that there is not more than one inch exposed threads on tube assembly (11) (detail C). Ensure that nut and bolt that attaches tube assembly (8) to hydraulic cylinder valve (7) is tightened sufficiently to remove axial play. The bolt must turn freely and cotter pin must be installed.

h. Adjust stop bolts (10) for 0.005 TO 0.015 inch clearance with bellcrank at full right and full left positions.

i. Install rigging fixture (T46) on pilot cyclic control stick.

(1) Remove four screws, washers, and nuts from holes in pilot floor outboard of stick support.

(2) Open damp of rigging fixture (T46) and place over stick with open end of damp aft. Engage pins in mounting holes.

j. Clamp cyclic stick in aft "A" of rigging fixture (T46). Hold bellcrank (8, figure 11-12) against fixed stop (9). Adjust tube assembly (16). Coat clevis threads with corrosion preventive compound (C43) when adjusting control tube. Connect tube to bellcrank (11).

k. Push tube assembly (7) upward to bottom out piston in top of hydraulic cylinder (4) and hold lever of valve (6) at top of travel. (See detail B, figure 11-12.) Adjust tube (7) to length to fit on bellcrank (8), then shorten two full turns and connect to bellcrank (8). Check exposed threads on tube (7) to ensure that they do not exceed one inch (detail B). Ensure that bolt attaches tube (7) to hydraulic cylinder valve (6) is tightened sufficiently to remove axial play. Back off to first castellation. Do not damp clevis. The bolt must turn freely, and cotter pin must be installed.

l. Adjust cyclic control hydraulic cylinder assemblies and attach to swashplate as follows:

(1) Clamp pilot cyclic control stick in center hole "N" of rigging fixture (T46).

(2) Fabricate a work aid as shown on figure 11-14 or use an eighteen inch scale as a measuring instrument. Set both swashplate forward horns to 12.82 inches (figure 11-15). Measure from transmission flange to lower edges of bolt holes. Maintain right horn at 12.82 inches  $\pm$  0.08 inch and set left horn to 12.52 inches  $\pm$  0.08 inch.

#### NOTE

An alternate method of measuring the swashplate in case it bottoms out on the swashplate support after the rigging has been completed is to measure from the bottom of the transmission top case to the bottom edge of the bolt holes using the following dimension, 13.63  $\pm$  0.06 inches for the right horn and 13.33  $\pm$  0.06 inches for the left hand horn.

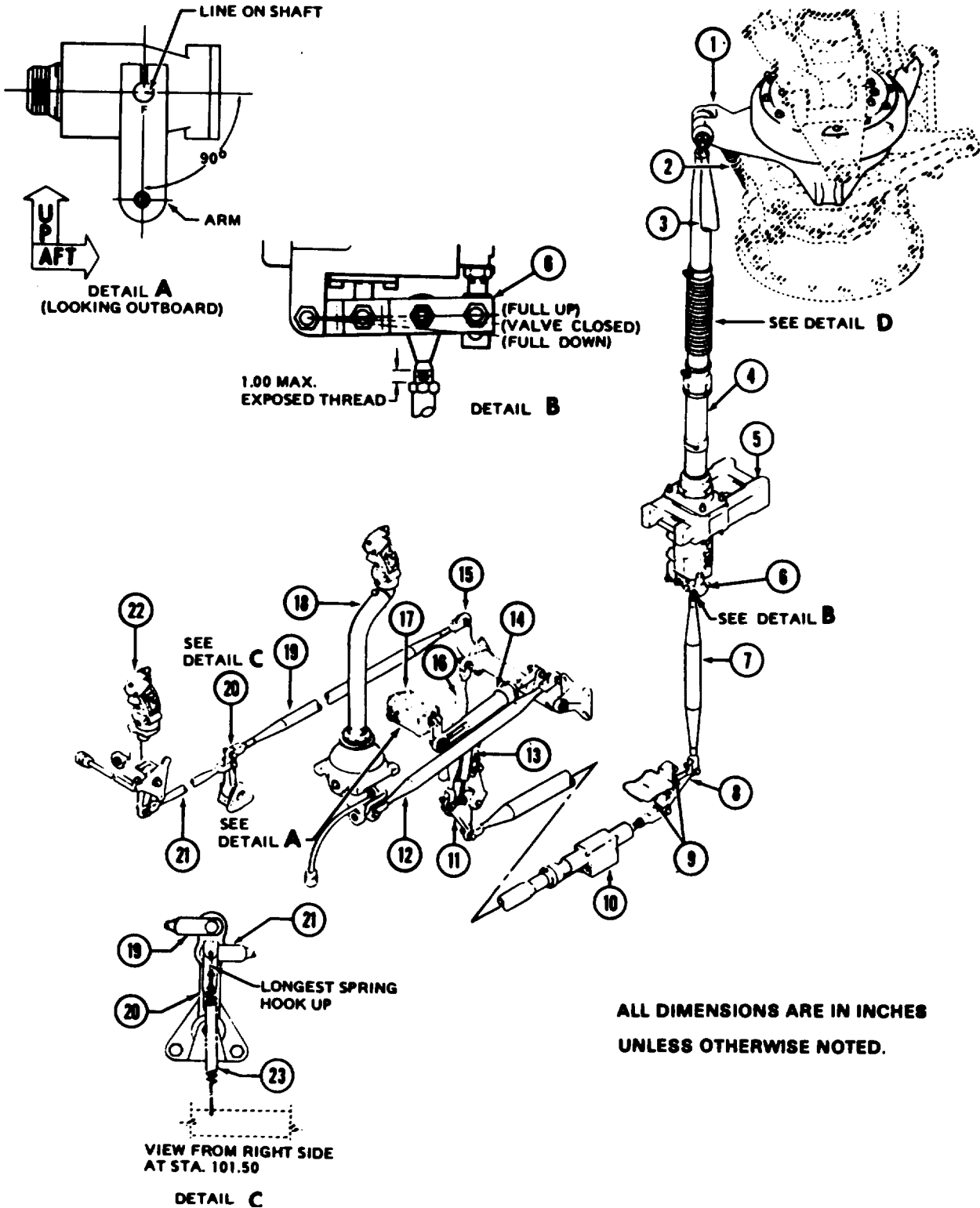

209001-161-1

Figure 11-12. Fore-and-Aft Cyclic Controls (Sheet 1 of 2)

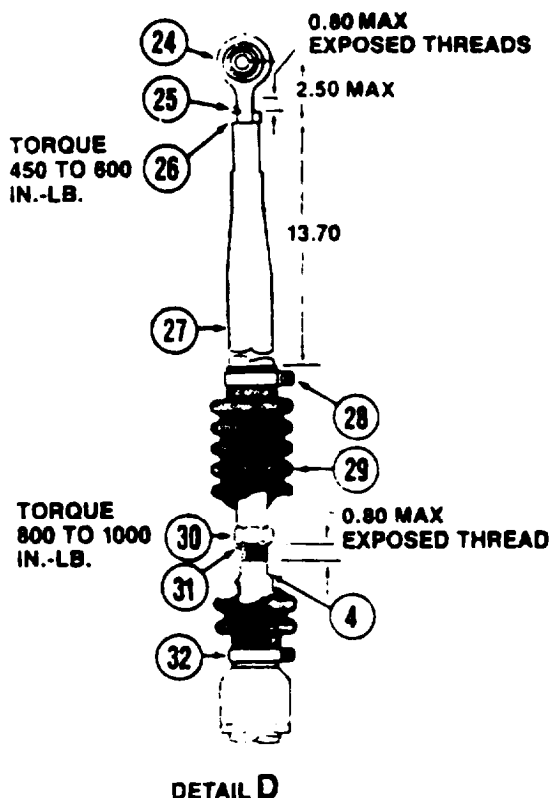

1. Swashplate
2. Spring
3. Elevator tube assembly
4. Hydraulic cylinder assembly
5. Cylinder support
6. Hydraulic cylinder valve lever
7. Tube assembly
8. Bellcrank
9. Fixed stops
10. Servo actuator (SCAS)
11. Bellcrank
12. Tube assembly
13. Transducer (SCAS)
14. Force gradient assembly
15. Jackshaft
16. Tube assembly
17. Magnetic brake
18. Pilot cyclic control stick
19. Tube assembly
20. Idler assembly
21. Tube assembly
22. Gunner cyclic control stick
23. Spring
24. Rod end bearing
25. Lock
26. Nut
27. Extension tube
28. Clamp
29. Boot
30. Nut
31. Lock
32. Clamp

**ALL DIMENSIONS IN INCHES UNLESS OTHERWISE NOTED.**

Figure 11-12. Fore-and-Aft Cyclic Controls (Sheet 2 of 2)

(3) Adjust hydraulic cylinder assembly (4, figure 11-12) for attachment to swashplate (1) as follows:

(a) Remove lockwire and loosen nut (26).



When setting hydraulic cylinder valve levers to top of travel, do not cause controls below cylinder to move or mis-rigging will occur.

(b) Ensure that swashplate (1) is at position set in step (2). Pushdown on extension tube (27) with just enough force to hold lever of hydraulic cylinder valve (6) at full up position as shown on detail B. Maintain this position and adjust rod end bearing (24) to fit on swashplate (1); then shorten one full turn of rod end bearing to compensate for change that occurs when hydraulic pressure is applied.

(c) Measure exposed threads on rod end bearing (24). If lock (25) can be installed and if less than 0.80 inch of thread is exposed, torque nut (26) 450 TO 600 inch-pounds, lockwire nut (26) to lock(25) with lockwire (C138) and proceed to step (4). If there are insufficient exposed threads to install lock (25) or if exposed threads on rod end bearing (24) are in excess of 0.80 inch, make adjustment at nut (30) as outlined in step (3) (d) through (i).

(d) Thread rod end bearing (24) into extension tube (27) until 0.80 inch of threads are exposed. Torque nut (26) 450 TO 600 inch-pounds and lockwire to lock (25) with lockwire (C138).

(e) Loosen clamps (28) and (32). Slide boot (29) up until nut (30) is exposed. Remove lockwire and loosen nut (30).

ALL DIMENSIONS ARE IN INCHES  
UNLESS OTHERWISE NOTED.

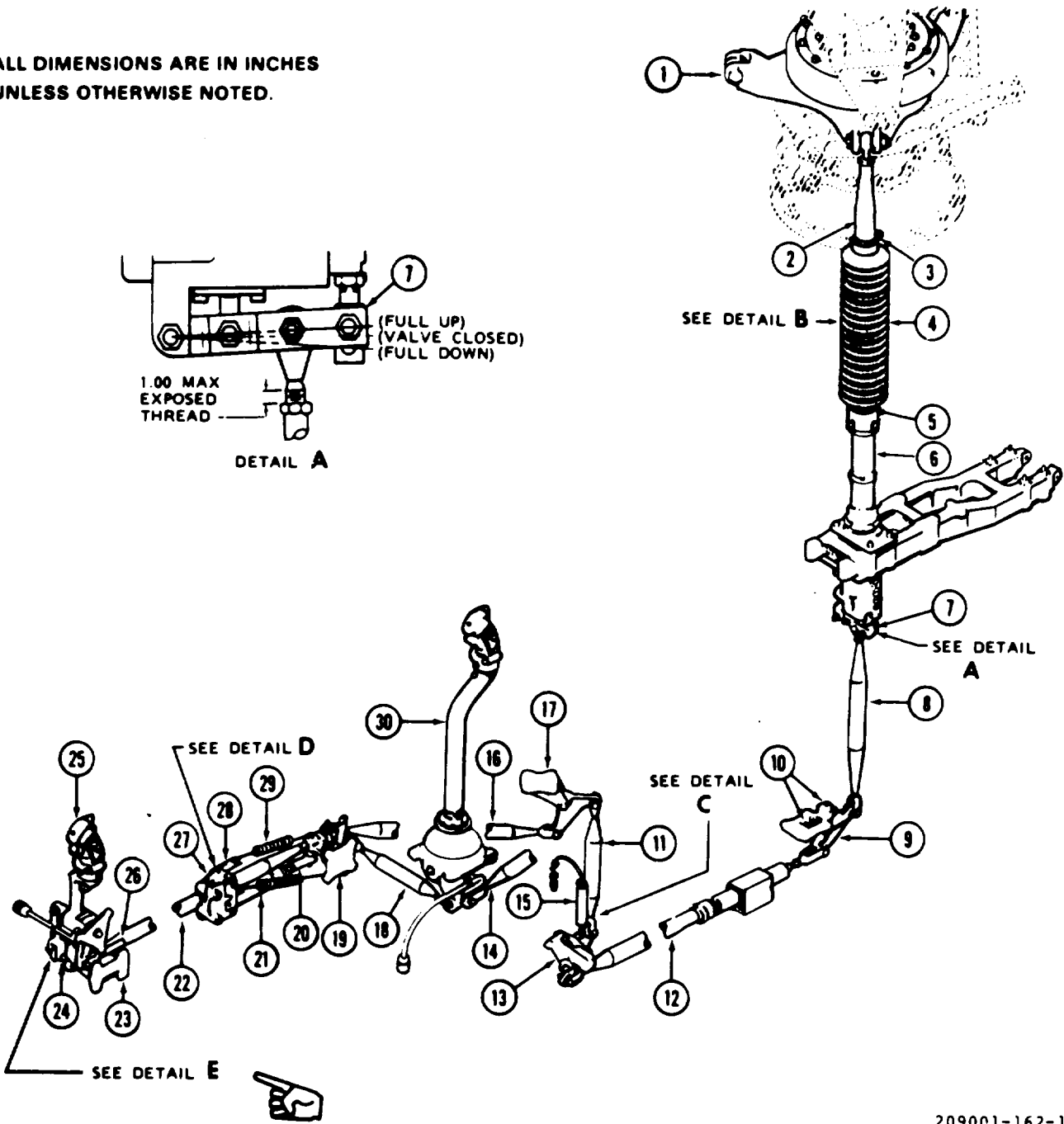

209001-162-1

- |                                   |                           |                                 |
|-----------------------------------|---------------------------|---------------------------------|
| 1. Swashplate                     | 11. Tube assembly         | 21. Force gradient              |
| 2. Extension tube                 | 12. Servo actuator (SCAS) | 22. Tube assembly               |
| 3. Clamp                          | 13. Bellcrank and support | 23. Bellcrank and support       |
| 4. Boot                           | 14. Tube assembly         | 24. Control link                |
| 5. Base                           | 15. Transducer (SCAS)     | 25. Gunner cyclic control stick |
| 6. Hydraulic cylinder assembly    | 16. Tube assembly         | 26. Tube assembly               |
| 7. Hydraulic cylinder valve lever | 17. Bellcrank and support | 27. Magnetic brake              |
| 8. Tube assembly                  | 18. Tube assembly         | 28. Plate                       |
| 9. Bellcrank and support          | 19. Bellcrank and support | 29. Springs                     |
| 10. Stop bolts                    | 20. Rod end bearing       | 30. Pilot cyclic control stick  |

Figure 11-13. Lateral Cyclic Controls (Sheet 1 of 2)



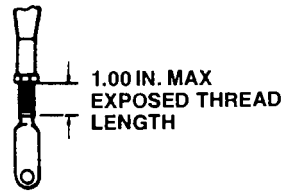
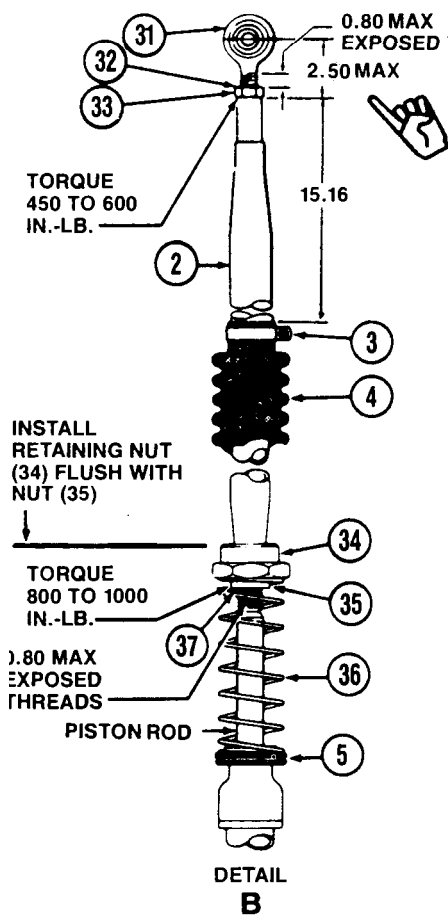

DETAIL C

- 31. Rod end bearing
- 32. Lock
- 33. Nut
- 34. Retaining nut
- 35. Nut
- 36. Spring
- 37. Lock

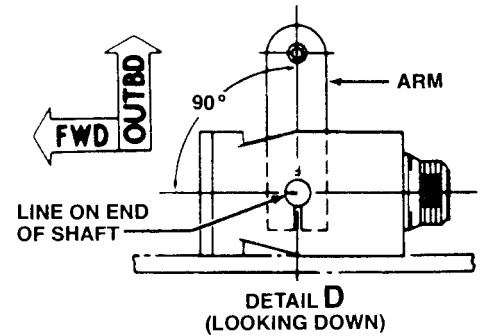

DETAIL D  
(LOOKING DOWN)

LINK, CYCLIC CONTROL  
(209-001-520-1)

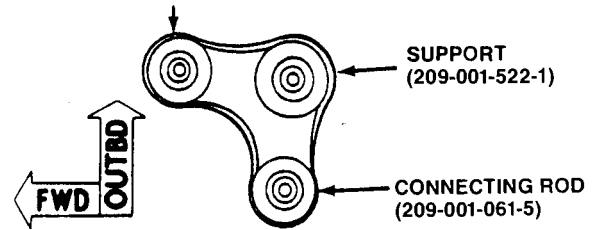

BELLCRANK  
(209-001-518-1)

DETAIL E

**CAUTION**

INSURE THAT CONNECTING ROD (209-001-061-5) IS CONNECTED TO BELLCRANK (209-001-518-1) ON THE LOWER SIDE OF SUPPORT (209-001-522-1).

**ALL DIMENSIONS ARE IN INCHES UNLESS OTHERWISE NOTED**

**Figure 11-13. Lateral Cyclic Controls (Sheet 2 of 2)**

**CAUTION**

**When setting hydraulic cylinder valve levers to top of travel, do not cause controls below cylinder to move or misrigging will occur.**

(f) Ensure that swashplate (1) is at position set in step (2). Push down on extension tube (27) with just enough force to hold lever of hydraulic valve (6) at full p position as shown on detail B. Maintain this position and adjust extension tube (27) on hydraulic cylinder assembly (4) to length so rod end bearing (24) will fit on

swashplate (1), then shorten one full turn of extension tube (27) to compensate for change that occurs when hydraulic power is applied.

(g) Measure length of exposed threads at nut (30). Maximum acceptable exposed thread is 0.80 inch.

(h) Torque nut (30) 800 TO 1000 inch-pounds and lockwire nut (30) to lock (31) with lockwire (C138).

(i) Position top of boot (29) 13.70 inches from top of extension tube (27) as shown on detail D and tighten clamp (28). Position lower end of boot (29) on hydraulic cylinder assembly (4) and tighten clamp (32).

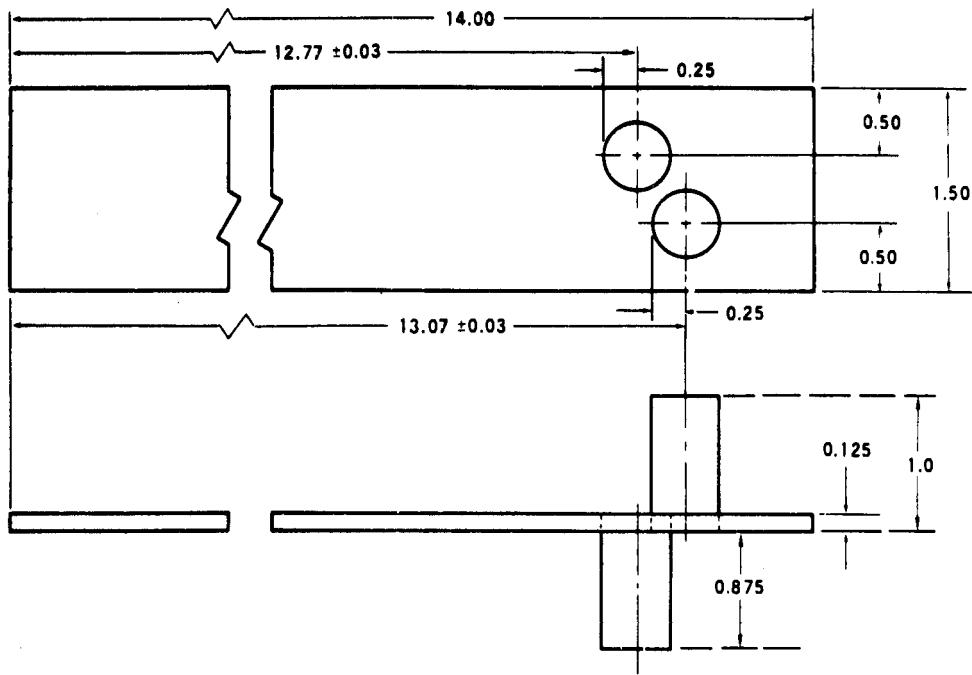

**Material: One Steel Strap 1 1/2 X 1/8 X 14 Inch  
Two Steel Pins 1 Inch Long x 1/2 Inch Diameter**

**Drill holes in strap and install pins in strap at location illustrated with one pin on each side of strap. Solder or braze pins in position. Apply one coat of primer to prevent corrosion.**

**ALL DIMENSIONS ARE IN INCHES UNLESS OTHERWISE NOTED.**

209900-482B

**Figure 11-14. Work Aid for Rigging Swashplate**

(4) Attach rod end bearing (24) elevator control tube (3), and spring (2) to swashplate (1). Comply with procedure outlined in paragraph 7-66.

(5) Adjust hydraulic cylinder assembly (6, figure 11-13) for attachment to swashplate (1) as follows:

(a) Remove lockwire and loosen nut (33).



**When setting hydraulic cylinder valve levers to top of travel, do not cause controls below cylinder to move or misrigging will occur.**

(b) Ensure that swashplate (1) is at position set in step (2). Push extension tube (2) down with just

enough force to hold lever of hydraulic cylinder valve (7) at full up position as shown on detail A. Maintain this position and adjust rod end bearing (31) to fit on swashplate (1); then shorten one full turn of rod end bearing to compensate for change that occurs when hydraulic pressure is applied.

(c) Measure length of exposed threads on rod end bearing (31). If less than **0.80** inch of threads are exposed, torque nut (33) **450 TO 600** inch-pounds, lockwire nut (33) to lock (32) with lockwire (C138), and proceed to step (6). If exposed threads on rod end bearing (31) are in excess of **0.80** inch, make adjustment at nut (35) as outlined in steps (d) through (1).

(d) Thread rod end bearing (31, figure 11-13) into extension tube (2) until **0.80** inch of threads are exposed. Torque nut (33) **450 TO 600** inch-pounds and lockwire to lock (32) with lockwire (C138).

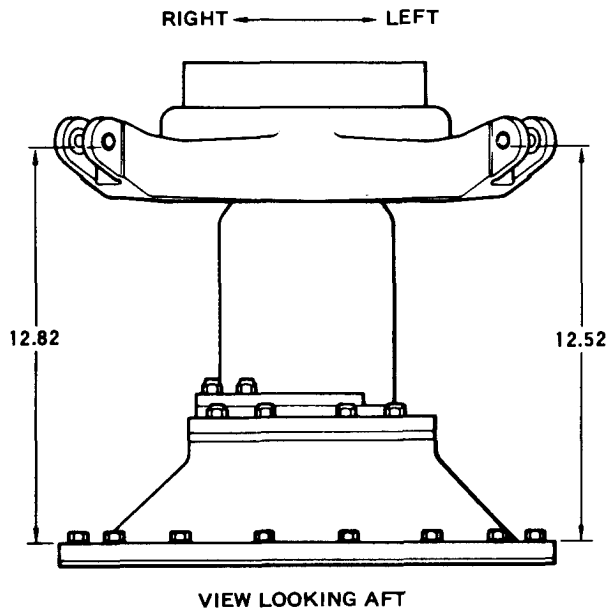

ALL DIMENSIONS ARE IN INCHES  
UNLESS OTHERWISE NOTED.

209401-2A

**Figure 11-15. Swashplate Rigging Dimensions**

(e) Loosen clamp (3) and remove boot (4) from base (5). Slide boot (4) up until nut (35) is exposed.

(f) Remove lockwire and remove retaining nut (34) and spring (36).

(g) Remove lockwire and loosen nut (35).



**When setting hydraulic cylinder valve levers to top of travel, do not cause control below cylinder to move or misrigging will occur.**

(h) Ensure that swashplate (1) is at position sat in step (2). Push down on extension tube (2) with just enough force to hold lever of hydraulic cylinder valve (7) at full up position as shown on detail A. Maintain this position and adjust extension tube (2) on hydraulic cylinder assembly (6) to length so rod end bearing (31) will fit on swashplate (1); then shorten one full turn of extension tube (2) to compensate for change that occurs when hydraulic pressure is applied.

(i) Measure length of exposed threads at nut (35). Maximum acceptable exposed thread is **0.80** inch.

(j) Torque nut (35) **800 TO 1000** inch-pounds and lockwire nut (35) to lock (37) with lockwire (C138).

(k) Position spring (36) on base (5). Thread retaining nut (34) on nut (35) until top of retaining nut (34) is flush with top of nut (35). Lockwire retaining nut (34) to nut (35) with lockwire (C138).

(l) Position bottom of boot (4) in groove on base (5). Position top of boot (4) **15.16** inches from top of extension tube (2) as shown on detail B. Tighten clamp (3).

(6) Attach rod end bearing (31) to swashplate (1). Comply with procedure outlined in paragraph 7-66.

m. Disconnect fore-and-aft SCAS actuator (10, figure 11-12) from bellcrank (11). Hold control stick full forward against stop. Position transducer (13) in retracted position, adjust rod end and connect on inboard side of bellcrank. Use large safety washer under screw head and aluminum alloy washers under nut and between rod end and bellcrank. Move control stick full aft against its stop and check that transducer does not bottom out. Reconnect fore and aft SCAS actuator (10).

n. Hold cyclic stick full forward. Hold arm on magnetic brake (17) full aft. Adjust rod end of force gradient (14) and connect to arm on jack-shaft (15). If there is not enough adjustment in force gradient (14), rotate the arm of the magnetic brake (17) one serration counter-clockwise.

o. Hold cyclic stick full right against stop. Position lateral SCAS transducer (15, figure 11-13) in its retracted position. Adjust rod end of transducer to fit, then screw one-half turn to prevent bottoming transducer. Connect transducer to inboard side of bellcrank (13).

p. Clamp cyclic stick in center hole "N" of rigging fixture (T46). Hold arm of magnetic brake (27) square within 2 degrees to structural beam on which brake is mounted. Adjust force gradient rod end bearing (20) and connect on bolt at underside of forward arm of bellcrank (19). Remove rigging fixture and move cyclic stick full right and full left to ensure that magnetic brake stop is not contacted.

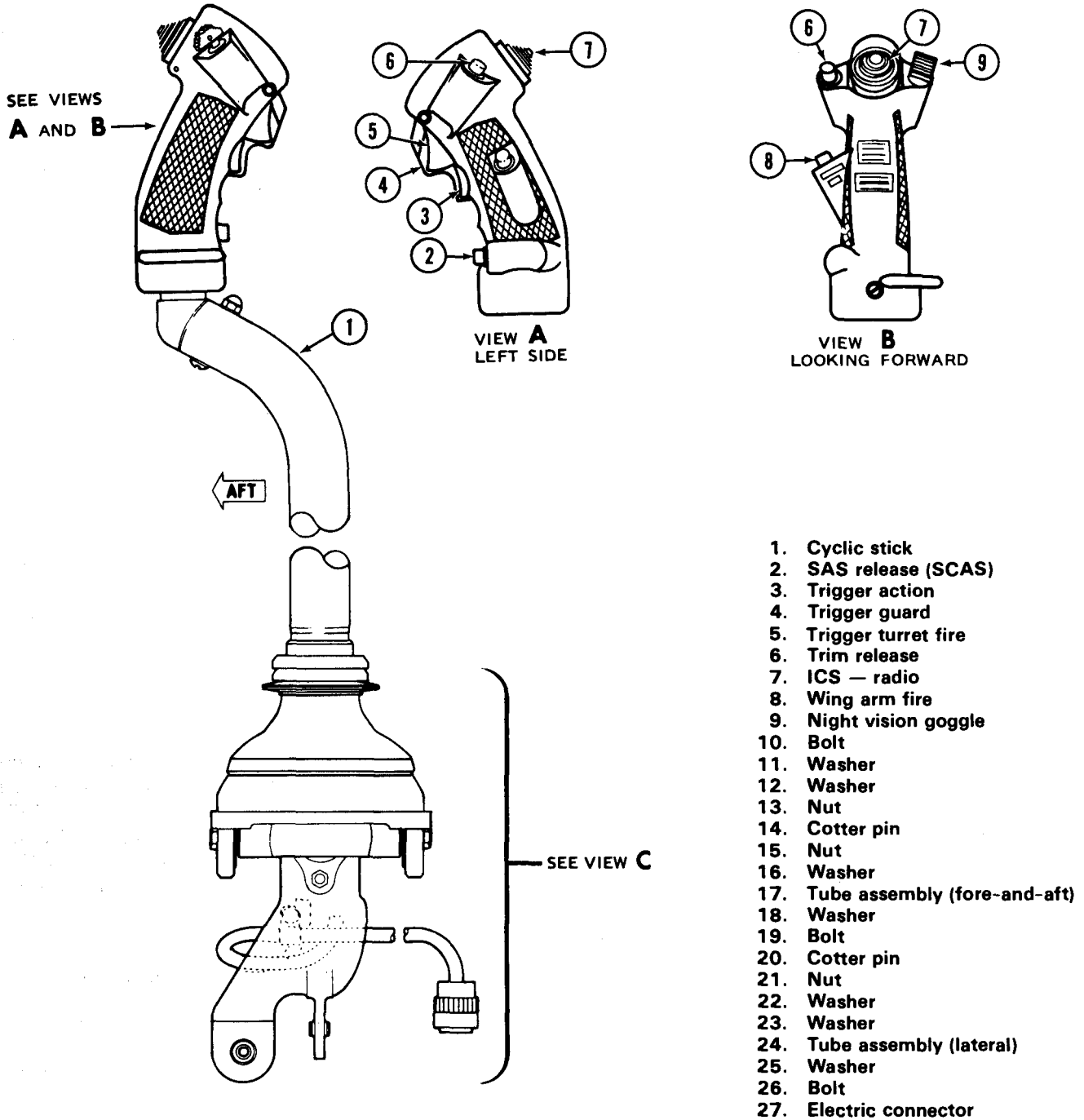

209001-163-1

Figure 11-16. Pilot Cyclic Stick Installation (Sheet 1 of 2)

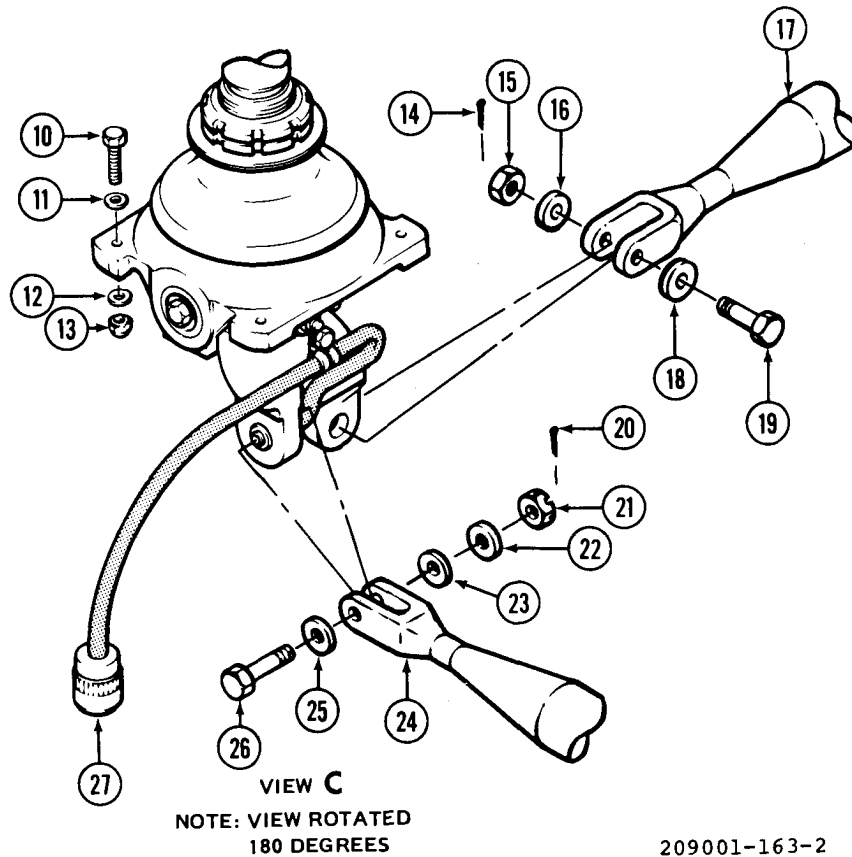

**Figure 11-16. Pilot Cyclic Stick Installation (Sheet 2 of 2)**

q. Check complete cyclic controls system for security and safetying of components.

r. Check operation with hydraulic power from a hydraulic test stand if available; if not available, move cyclic controls through full throw manually and ensure that there is no binding or interference.

s. Rig and connect elevator controls (paragraph 11-138).

t. Perform maintenance test flight (TM 55-1520-236-MTF).

**11-30. PILOT CYCLIC STICK.**

**11-31. DESCRIPTION - PILOT CYCLIC STICK.**

The conventional type control stick is mounted through the floor in front of the pilot seat. It is

mounted through gimbal bearings in a bell-shaped support. The grip attached at top of stick is equipped with the following switches: SAS REL, TRIGGER ACTION, TRIGGER TURRET FIRE, WING ARM FIRE, TRIM REL, ICS-RADIO, and NIGHT VISION GOGGLE. Pilot cyclic stick has a mechanical advantage of 2 to 1 ratio over the gunner cyclic stick.

**Premaintenance Requirements for Pilot Cyclic Stick**

Conditions	Requirements
Model	AH-1S
Part No. or Serial No.	All
Special Tools	None
Test Equipment	Feeler Gage

Conditions	Requirements
Support Equipment	None
Minimum Personnel Required	Two
Consumable Materials	(C14), (C88), (C74), (C91), (C105), (C112)
Special Environmental Conditions	None

### 11-32. REMOVAL-PILOT CYCLIC STICK.

- a. Obtain access to area below pilot floor through door in panel at top of ammunition compartment.
- b. Disconnect lateral system tube assembly (24, figure 11-16) and fore-and-aft tube assembly (17) from levers on lower end of control stick.
- c. Disconnect electrical cable connector (27) of control stick from the receptacle.
- d. Detach stick support from floor by removing four bolts (10) with nuts (13) and washers (11 and 12).
- e. Lift stick assembly out of floor opening.

### 11-33. DISASSEMBLY - PILOT CYCLIC STICK (AVIM).

- a. Identify and tag wires of cable (42, figure 11-17) for sequence of installation in electrical connector (43); then remove connector from electrical cable (42).
- b. Remove bolt (36), washer (35), and clamp (34) attaching cable assembly to lever assembly (32).

**NOTE**

**Use care when removing grip from stick because electrical wires of grip must be removed from inside of stick.**

- c. Remove grip assembly (1) from elbow (2) by removing nut (45), washer (46), and screw (47), see detail A.

d. Remove elbow (2) from pilot cyclic stick (5) by removing nut (4), washers (3 and 6), and bolt (7). Remove old primer from ends of elbow with clean cloth saturated by MEK (C74).

e. Separate pilot cyclic stick (5) from lever assembly (32) by removing cotter pin (29), nut (30), washers (31 and 40), and bolt (39).

**NOTE**

**Save shims (26) located on bolts (18) between support (17) and gimbal (22).**

f. Separate support (17) from gimbal (22) by removing two cotter pins (20), two nuts (21), and two washers (19). Remove bolts (18) and shims (26).

g. Remove remaining cotter pins (23), nuts (24), and washers (25). Remove bolts (33) with shims (38) and separate lever assembly (32) from gimbal (22). Save shims (38) for reuse during installation.

h. Rotate nuts (8 and 9) counterclockwise until clear of threads on collar (15). Remove spring tension washers (10 and 11), spacer (12), and bell assembly (13).

### 11-34. INSPECTION - PILOT CYCLIC STICK.

- a. Inspect washers (10 and 11, figure 11-17) for damage which will affect serviceability.
- b. Inspect bearings (27, 37, 41 and 44) for roughness, freedom of movement, and wear in excess of **0.005** inch radial and **0.030** inch axial play.
- c. Inspect lever assembly (32) and gimbal (22) using fluorescent penetrant in accordance with TM 43-0103.
- d. Inspect shims (26 and 38) for wear and/or damage.
- e. Inspect grip assembly (1) for cracks. Inspect switches for operation of detent and obvious damage.
- f. Inspect electrical cable (42) and electrical connector (43) for loose connections, broken terminals, pins and/or soldered connections. Inspect cable for obvious damage such as chafing.
- g. Inspect elbow (2) for cracks and for elongation of bolt holes.

h. Inspect collar (15) for cracks and damaged threads.

i. Inspect nuts (8 and 9) for damaged threads.

j. Inspect stick (5) for cracks.

**11-35. REPAIR OR REPLACEMENT -  
PILOT CYCLIC STICK (AVIM).**

a. Replace components that fail to meet inspection requirements of paragraph 11-34.

b. Replace elbow (2, figure 11-17) as follows:

(1) Remove nut (4), washers (3 and 6) and bolt (7).

(2) Remove elbow (2) from cyclic stick.

(3) Prime elbow with primer (C88) or (C91). Align holes in elbow with holes in cyclic stick and install.

(4) Install bolt (7), washers (3 and 6) and nut (4).





b.1. Replace sheet felt (17A) (C53.3) in bell (13) if worn or damaged.

**WARNING**

**Cleaning solvent is flammable and toxic. Provide adequate ventilation. Avoid prolonged breathing of solvent vapors and contact with skin or eyes.**

(1) Scrape old sheet felt (C53.3) out of bell (13) and clean with MEK (C74).

(2) Apply cement (C28.1) to new sheet felt (C53.3) and install in bell (13).

c. Replace collar (15) as follows:

(1) If installed, remove lever assembly (32) from end of cyclic stick (paragraph 11-38).

(2) Remove three rivets (3, figure 11-18), then slide collar (2) off pilot cyclic stick (1).

(3) Inspect bushing (4). If damaged, install new bushing as follows:

(a) Chill end of cyclic stick to minus 60 degrees F (minus 51 degrees C). Use suitable punch and mallet on bushing (4) to break the adhesive. Remove bushing.

(b) Ensure that old adhesive is removed from inside cyclic stick.

(c) Mix and apply adhesive (C14) to bushing. Refer to table 1-11, for adhesive, mix ratio, pot life and curing schedule.

(d) Position slot in new bushing as shown in detail B, figure 11-18, and install bushing into cyclic stick until flush with end of stick.

(e) With bushing aligned as shown in detail B, figure 11-18, drill two **0.24965 TO 0.2500** inch

diameter holes to match holes in pilot cyclic stick (5) and lever assembly (32, figure 11-17).

(4) Prime area of pilot cyclic stick (1, figure 11-18) where collar (2) will be installed with primer (C88 or 91). Slide new collar onto cyclic stick (1). Position collar (2) so that flange is **3.820** inches from center of hole in end of cyclic stick (1).

(5) With collar (2) positioned as shown in detail A, figure 11-18, drill three rivet holes **118** degrees to **122** degrees apart to match with holes in pilot cyclic stick (1). Center of rivet to be **0.20** inch from end of collar as shown (figure 11-18).

(6) Install three MS20470AD4 or MS20600AD4 rivets (3).

d. Replace bearings (41 and 44, figure 11-17) if rough, binding or worn beyond limits. Refer to paragraph 11-35.

**11-36. ASSEMBLY - PILOT CYCLIC STICK (AVIM).**

**WARNING**

**Cleaning solvent is flammable and toxic. Provide adequate ventilation. Avoid prolonged breathing of solvent vapors and contact with skin or eyes.**

**CAUTION**

**Do not allow solvent to enter bearings or electrical components.**

a. Clean exposed surfaces with a clean cloth dampened with dry cleaning solvent (C112).

b. Install bell assembly (13, figure 11-17), spacer (12), two washers (10 and 11) and two spanner nuts (8 and 9) over end of pilot cyclic stick (15) onto collar (15).

**NOTE**

**Separate wires from grip assembly (1) so that the screws is between bundles.**

c. Apply unthinned primer (C88 or C91) to elbow (2) and install elbow screw (47), washer (46) and

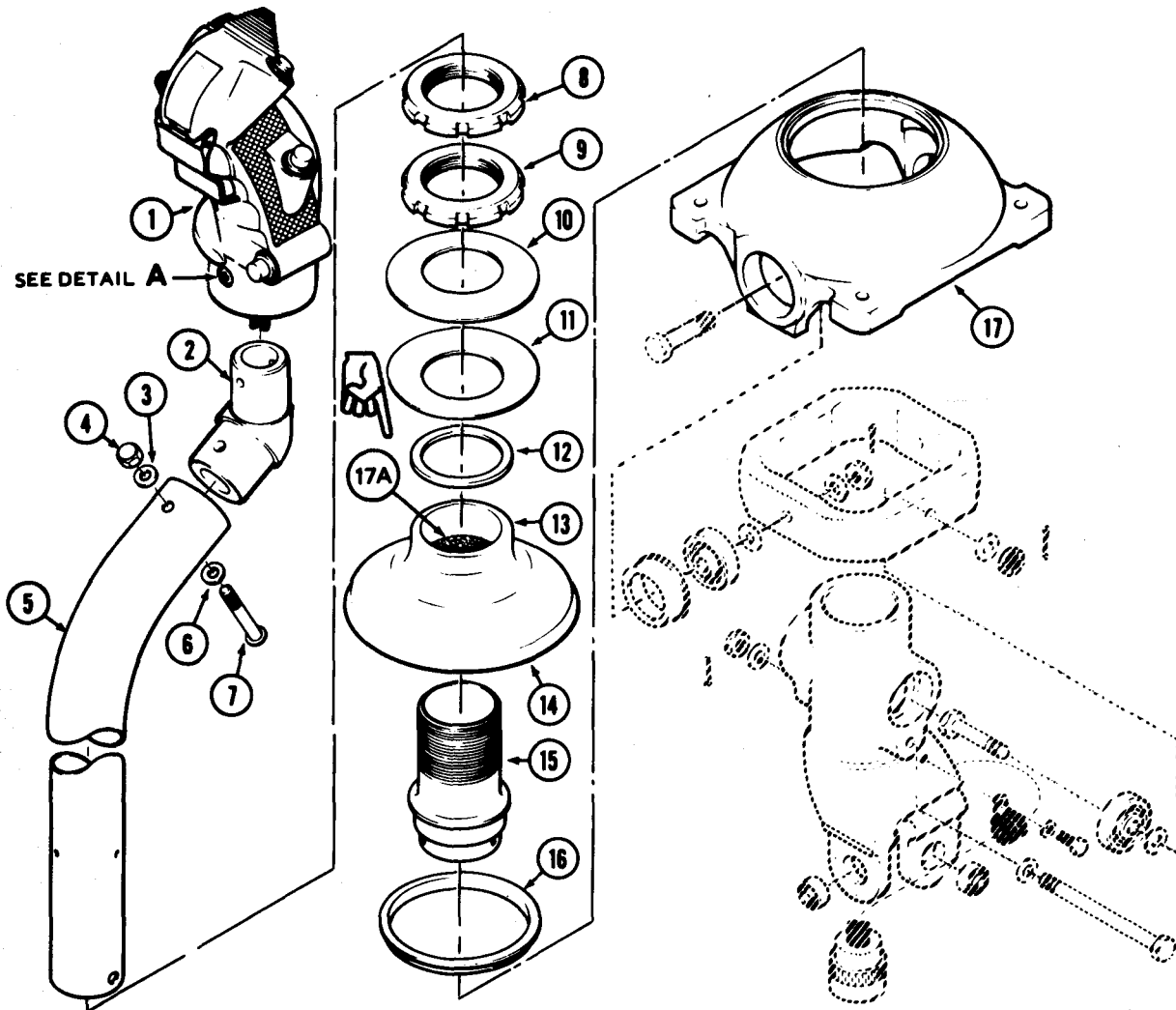

- 1. Grip assembly
- 2. Elbow
- 3. Washer
- 4. Nut
- 5. Pilot cyclic stick
- 6. Washer
- 7. Bolt
- 8. Spanner nut
- 9. Spanner nut

- 10. Spring tension washer
- 11. Spring tension washer
- 12. Spacer
- 13. Bell assembly
- 14. Liner
- 15. Collar
- 16. Sleeve
- 17. Support
- 17A. Sheet felt

209001-165-1

Figure 11-17. Pilot Cyclic Stick Assembly (Sheet 1 of 2)

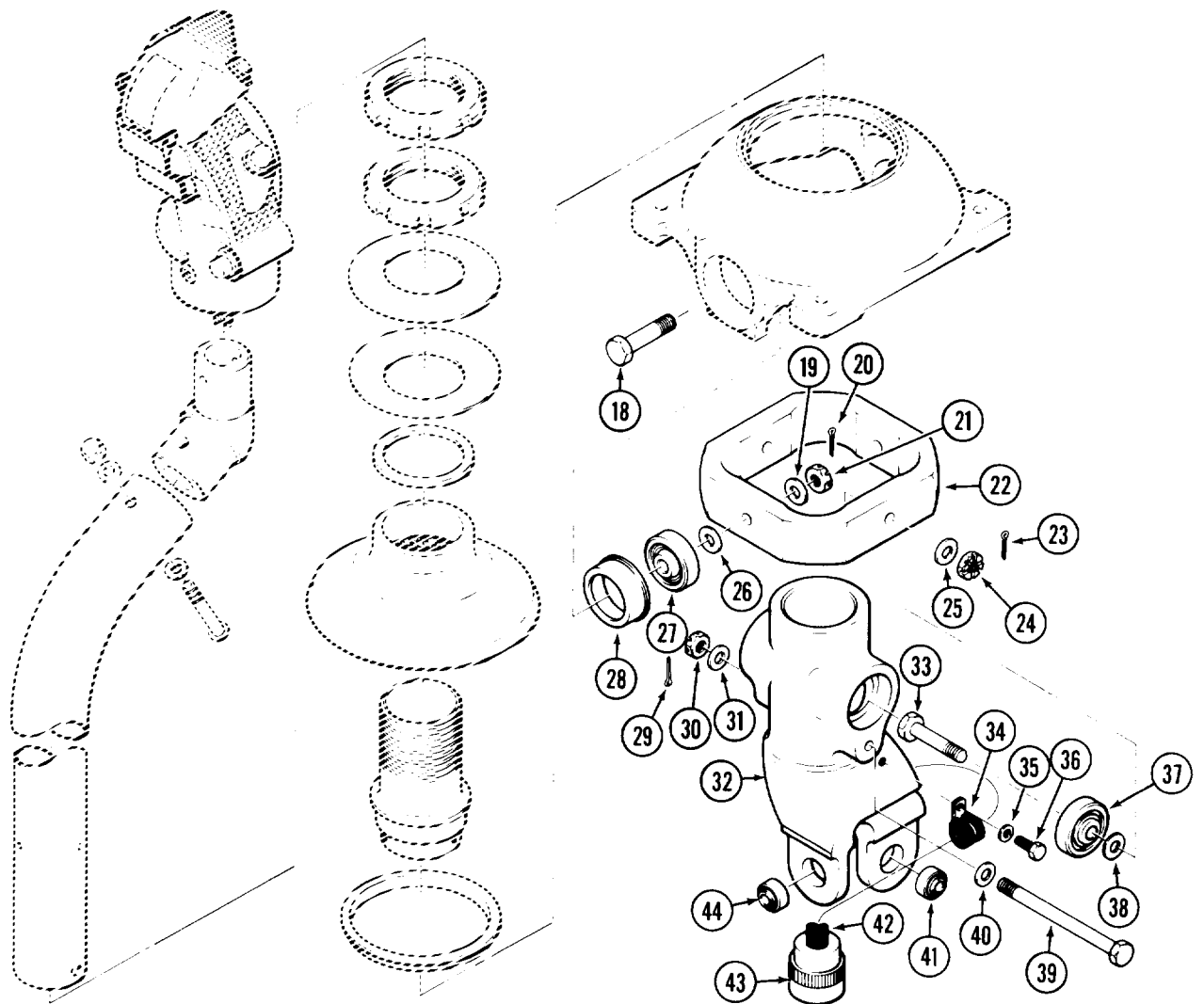

- 18. Bolt
- 19. Washer
- 20. Cotter pin
- 21. Nut
- 22. Gimbal
- 23. Cotter pin
- 24. Nut
- 25. Washer
- 26. Shim
- 27. Bearing
- 28. Sleeve
- 29. Cotter pin
- 30. Nut
- 31. Washer
- 32. Lever assembly

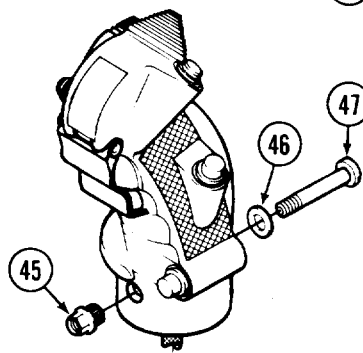

DETAIL A

- 33. Bolt
- 34. Clamp
- 35. Washer
- 36. Bolt
- 37. Bearing
- 38. Shim
- 39. Bolt
- 40. Washer
- 41. Bearing
- 42. Electrical cable
- 43. Electrical connector
- 44. Bearing
- 45. Spline nut
- 46. Washer
- 47. Screw

209001-165-2

Figure 11-17. Pilot Cyclic Stick Assembly (Sheet 2 of 2)

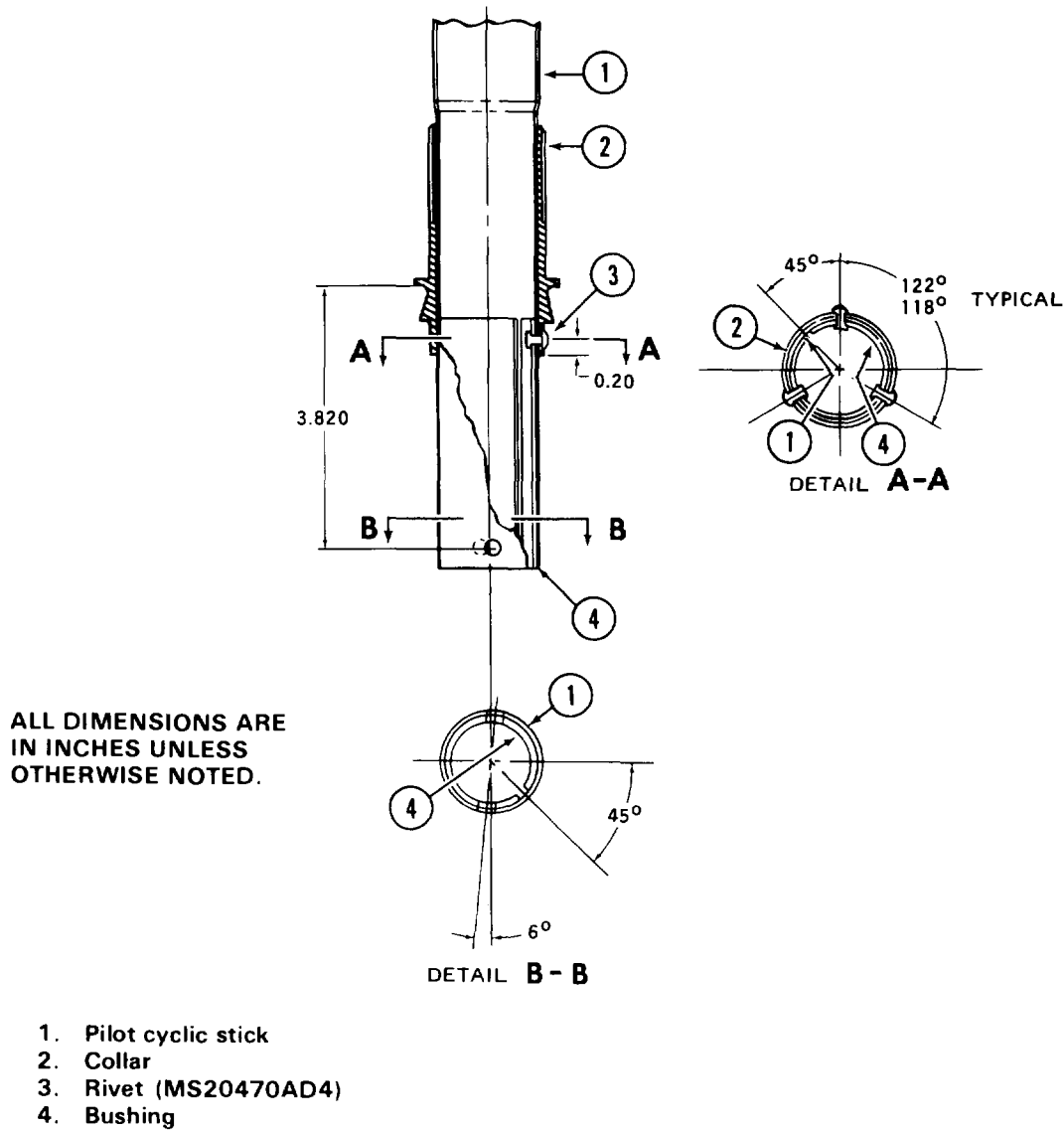

209001-111B

Figure 11-18. Collar and Bushing Installation

spline nut (45) to grip assembly (1). Route electrical cable (42) through pilot cyclic stick (5). Apply unthinned primer to end of elbow and attach elbow to pilot cyclic stick with bolt (7), washers (6 and 3) and nut (4).

d. Install two bearings (37 and 44) in lever assembly (32).

e. Assemble lever assembly (32) and gimbal (22) with sufficient shims (38) between bearing and gimbal to prevent lever side play. Distribute shims on each side so that the centerline of bore in lever is concentric within **0.005** inch with center of gimbal.

Install bolts (33) from inside of lever assembly (32) to outside of gimbal (22) and secure with washer (25), nut (24), and cotter pin (23).

f. Install bearings (27) in support (17) and install support over bottom end of pilot cyclic stick.

g. Route electrical cable (42) through lever assembly (32) while inserting pilot cyclic stick (15) into lever assembly (32) as shown on figure 11-17. Align hole in lever assembly (32) with hole in pilot cyclic stick (5). Install bolt (39), washers (31 and 40), nut (30) and secure with cotter pin (29).

**h.** Align holes in support bearings (27) with gimbal (22). Install bolts (18) from outside through bearing (27) with sufficient shims (26) between support and gimbal to prevent side play and maintain center of support (17) concentric within **0.005** inch of gimbal center.

**i.** Secure bolts (18) with washer (19), nut (21), and cotter pin (20).

**j.** Attach electrical cable (42) to lever assembly (32), using clamp (34), bolt (36), and washer (35). Ensure that all slack is removed from wires in stick and maximum distance between electrical cable (42) and lever (32) is **0.050** inch and is snug against lever (32).

**k.** Remove masking tape from electrical cable (42). Install electrical connector (43) on electrical cable (42) with wires of cable installed in original plug position.

**l.** Adjust pilot cyclic stick friction (paragraph 11-37).

### 11-37. ADJUSTMENT - PILOT CYCLIC STICK.

**a.** Place support (17, figure 11-17) of pilot cyclic stick in a suitable device to hold it immovable with pilot cyclic stick (5) perpendicular to the support.

**b.** Screw lower spanner nut (9) on threads until nut is against washers (10 and 11).

**c.** Adjust stick friction as follows:

**(1)** Adjust two lower spanner nuts (figure 11-19) to obtain **2.0 ± 0.25** pounds breakaway force from neutral positions. Measure breakaway force with a force gage (fish scale) at center of stick grip.

**(2)** Hold lower spanner nut. Torque upper spanner nut **450 TO 500** inch-pounds, Recheck breakaway torque and readjust if required.

### 11-38. INSTALLATION - PILOT CYCLIC STICK.

**a.** Place pilot cyclic stick in mounting hole of pilot floor.

**b.** Align holes and install four bolts through the stick support and floor. Use thin alloy washers under bolt heads and nuts.

**c.** Apply sealant (C105) to fill in structure fore-and-aft of stick support and form a fillet between support and floor.

**d.** Connect tube assembly (12, figure 11-12). Use one washer under bolt head and one washer under nut. Secure with cotter pin.

**e.** Connect tube assembly (18, figure 11-13). Use one washer under bolt head and one washer under nut. Secure with cotter pin.

**f.** Connect electrical connector (43, figure 11-17), of stick to receptacle provided.

**g.** Check complete control system for security and safetying of components.

### 11-39. OPERATIONAL CHECK - PILOT CYCLIC STICK.

**a.** Check operation of pilots cyclic stick through full range of movement (paragraph 11-29).

**b.** Install access panel in top of ammunition compartment.

**c.** Perform maintenance test flight. Refer to TM 55-1520-236 MTF.

### 11-40. GUNNER CYCLIC STICK.

### 11-41. DESCRIPTION - GUNNER CYCLIC STICK.

The gunner cyclic control stick is mounted on gunner right side console. It is attached on a support through pivot bearings which allow both fore-and-aft and lateral movements. The grip, attached at top of stick, is functionally identical to grip used on pilot cyclic stick and is equipped with identical control switches (figure 11-20). Because of the difference in the pilot and gunner cyclic systems, it requires more force (**1.63 TO 1** ratio) to move the gunner cyclic stick than it does to move the pilot cyclic stick.

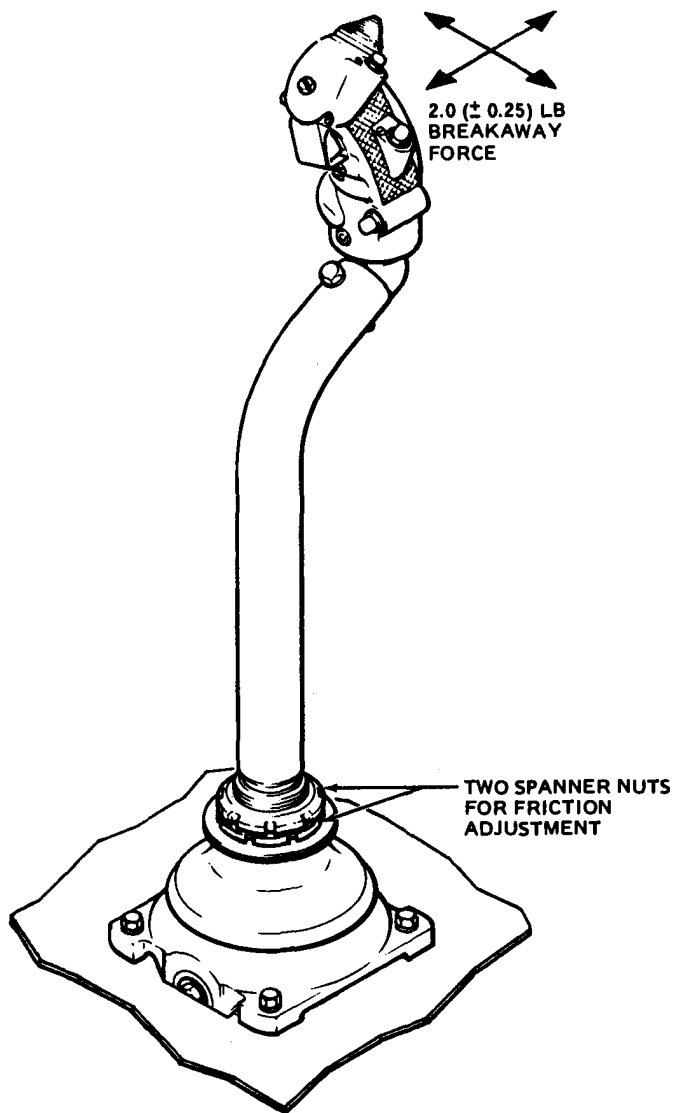

209001-15B

**Figure 11-19. Pilot Cyclic Stick Friction Adjustment**

**Premaintenance Requirements for  
Gunner Cyclic Stick**

Conditions	Requirements
Model	AH-1S
Part No. or Serial No.	All
Special Tools	(T48), (T61)
Test Equipment	Feeler Gage

Conditions	Requirements
Support Equipment	None
Minimum Personnel Required	Two
Consumable Materials (C112)	
Special Environmental Conditions	None

### 11-42. REMOVAL - GUNNER CYCLIC STICK (AVIM).

- a. Remove screw mounted panel from right side of fuselage above ammunition compartment for access to stick.
- b. Disconnect electrical cable plug (9, figure 11-20) of stick from receptacle in console.
- c. Disconnect fore-and-aft system tube assembly (13) by removing bolt (15), washers (12 and 14), nut (11), and cotter pin (10).
- d. Disconnect lateral system link (21) by removing bolts (23), washers (20 and 22), nut (19), and cotter pin (18).
- e. Detach boot (26) from console by removing screw (28) and washer (27) on outboard side and screw (28) and washer (27) on inboard side of stick.
- f. Detach stick support from console structure by removing three bolts (24) and washers (25), Lift stick assembly out of console.

### 11-43. DISASSEMBLY - GUNNER CYCLIC STICK (AVIM).

- a. Tag wires of electrical cable (5, figure 11-21) for identification, number and installation sequence in electrical connector (4) then remove connector plug from cable assembly.
- b. Remove clamp (18) from electrical cable (5) by removing screw (20), washers (19 and 23) and nut (26).
- c. Remove clamp (37) from bracket (38), by removing screw (35), washers (36 and 39) and nut (40), see detail C.
- d. Remove grip (1) from upper end of stick (31) by removing screw (17, figure 11-20) and apply gentle upward pressure on grip to prevent injury to attached cable assembly.
- e. Separate stick (31, figure 11-21) from bellcrank (9) and support (10) by removing cotter pin (21), nut (22), washers (7 and 24), and bolt (6). Remove bracket (38) from bolt.

f. Separate bellcrank (9) from support (10) by removing cotter pin (17), nut (16), washers (12 and 15), and bolt (13).

g. Remove clamp support (29) by removing nut (3), washers (2 and 28), and screw (27).

### 11-44. INSPECTION - GUNNER CYCLIC STICK.

- a. Inspect grip (1, figure 11-21) for cracks. No cracks are acceptable.
- b. Inspect bellcrank (9), support (10), and cyclic control stick (31) for scratches, nicks, dents, and corrosion. Minor mechanical damage and superficial corrosion is acceptable if polished out.
- c. Inspect bellcrank (9), support (10) and cyclic control stick (31) for cracks by fluorescent penetrant method (TM 43-0103). No cracks are acceptable.
- d. Inspect switches for damage that could affect function of the switches.
- e. Inspect cable (5) for loose connectors, broken terminals, pins, and/or soldered connections to switches in grip (1). Inspect cable wires for breaks and/or chafing.
- f. Inspect bearings (8, 11, 14, 25, and 30) for roughness and wear. Maximum acceptable wear (play) is **0.005 TO 0.030** inch.

### 11-45. REPAIR OR REPLACEMENT - GUNNER CYCLIC STICK (AVIM).

Replace components that fail to meet inspection requirements of paragraph 11-44.

- b. Replace defective switches or electrical cable as required (paragraph 9-20 and Appendix F).
- c. Refer to paragraph 11-165 for instructions to replace bearings. If bearing (30) must be replaced, use staking tool (T48) in place of staking tool (T61).
- d. Polish out minor corrosion and mechanical damage from parts in accordance with general repair procedures in paragraph 11-158.

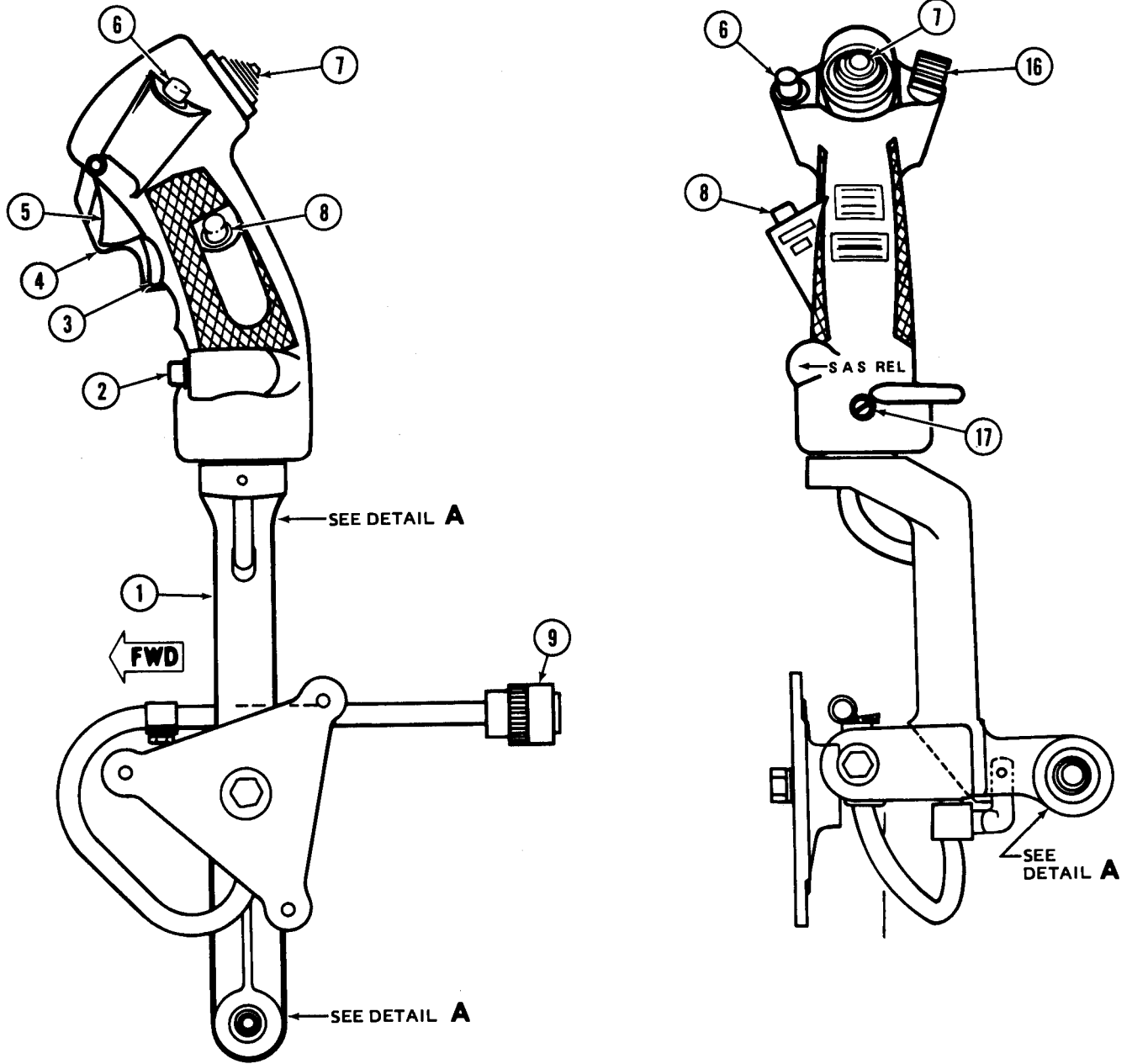

209001-167-1

Figure 11-20. Gunner Cyclic Stick Installation (Sheet 1 of 2)



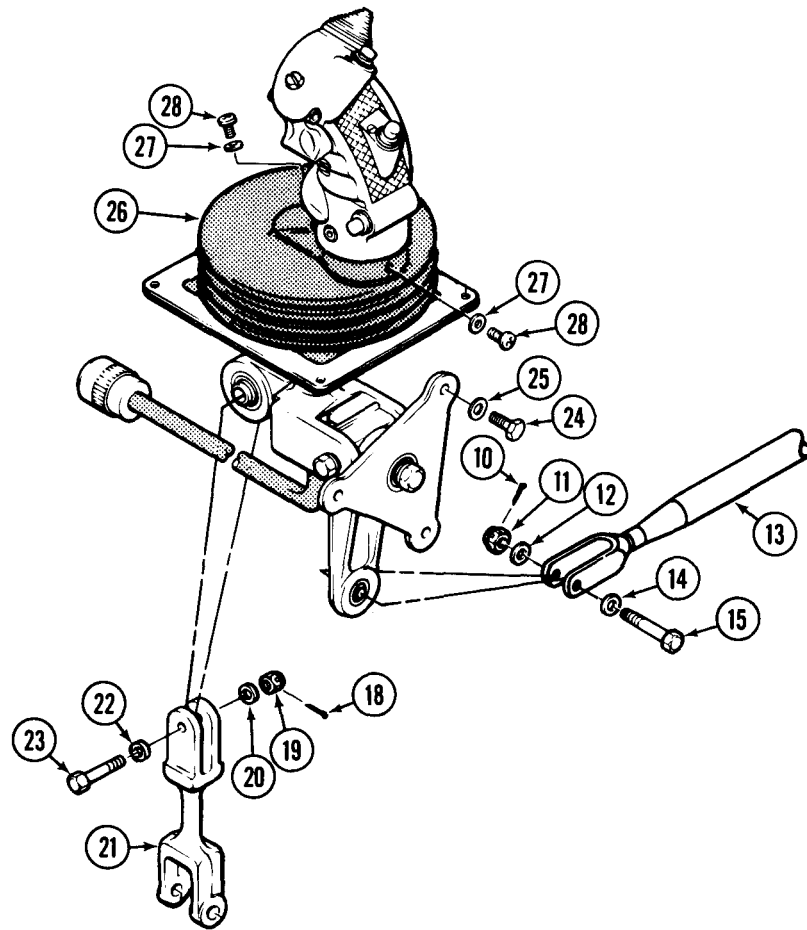

DETAIL A

- |   |   |
|---|---|
| <ul style="list-style-type: none"> <li>1. Gunner cyclic stick</li> <li>2. SAS release (SCAS) switch</li> <li>3. Trigger guard</li> <li>4. Trigger guard</li> <li>5. Trigger turret fire switch</li> <li>6. Trim release switch</li> <li>7. ICS — radio switch</li> <li>8. Wing arm fire switch</li> <li>9. Electrical plug</li> <li>10. Cotter pin</li> <li>11. Nut</li> <li>12. Washer</li> <li>13. Control tube assembly</li> <li>14. Washer</li> </ul> | <ul style="list-style-type: none"> <li>15. Bolt</li> <li>16. Night vision goggle switch</li> <li>17. Screw</li> <li>18. Cotter pin</li> <li>19. Nut</li> <li>20. Washer</li> <li>21. Link</li> <li>22. Washer</li> <li>23. Bolt</li> <li>24. Bolt</li> <li>25. Washer</li> <li>26. Boot</li> <li>27. Washer</li> <li>28. Screw</li> </ul> |
|---|---|

209001-167-2

Figure 11-20. Gunner Cyclic Stick Installation (Sheet 2 of 2)

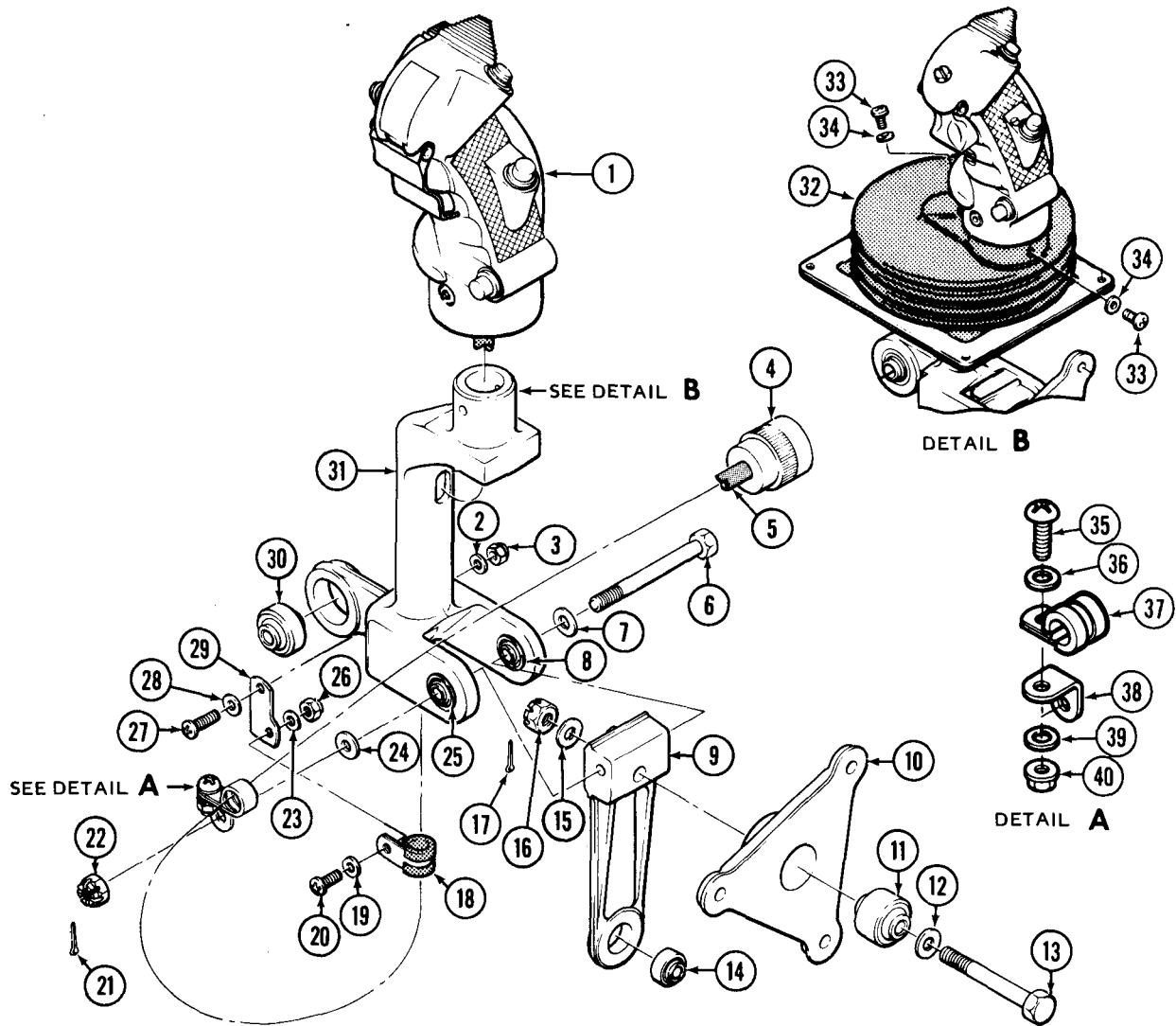

- |                         |                |                          |
|-------------------------|----------------|--------------------------|
| 1. Grip assembly        | 15. Washer     | 29. Clamp support        |
| 2. Washer               | 16. Nut        | 30. Bearing              |
| 3. Nut                  | 17. Cotter pin | 31. Cyclic control stick |
| 4. Electrical connector | 18. Clamp      | 32. Boot                 |
| 5. Electrical cable     | 19. Washer     | 33. Screw                |
| 6. Bolt                 | 20. Screw      | 34. Washers              |
| 7. Washer               | 21. Cotter pin | 35. Screw                |
| 8. Bearing              | 22. Nut        | 36. Washer               |
| 9. Bellcrank            | 23. Washer     | 37. Clamp                |
| 10. Support assembly    | 24. Washer     | 38. Bracket              |
| 11. Bearing             | 25. Bearing    | 39. Washer               |
| 12. Washer              | 26. Nut        | 40. Nut                  |
| 13. Bolt                | 27. Screw      |                          |
| 14. Bearing             | 28. Washer     |                          |

209001-169

Figure 11-21. Gunner Cyclic Stick Assembly

**11-46. ASSEMBLY - GUNNER CYCLIC STICK (AVIM).****WARNING**

Cleaning solvent is flammable and toxic. Provide adequate ventilation. Avoid prolonged breathing of solvent vapors and contact with skin or eyes.

**CAUTION**

Do not allow solvent to enter bearings or electrical components.

- a. Clean exposed surfaces by wiping with a cloth dampened with dry cleaning solvent (C112).
- b. Place one washer (12, figure 11-21) under head of bolt (13), insert bolt through support (10) and through bellcrank (9). Secure bolt with washer (15), nut (16), and cotter pin (17).
- c. Separate two wire bundles in cable (5) so that screw (17, figure 11-20) can be installed between the two wire bundles without damage to cable (5, figure 11-21).
- d. Route cable (5) through top of cyclic stick and install grip (1) with holes in grip aligned with holes in cyclic stick (31). Install screw (17, figure 11-20) through grip and stick. Ensure that screw is between cable bundles (5, figure 11-21).
- e. If removed, attach clamp support (29) to cyclic stick with screw (27), washers (2 and 28), and nut (3).
- f. Install cable (5) in clamp (18) and attach clamp to support (29) with screw (20), washers (19 and 23), and nut (26).
- g. Position bellcrank (9) with support (10) between ears of cyclic stick (31). If removed, install floating bearing (25) in one ear of cyclic stick. Align holes in bellcrank with bearings (8 and 25) and install bolt (6) with one washer (7) under head through cyclic stick and bellcrank.
- h. Install cable (5) in clamp (37) and secure with screw (35), washers (36 and 39), and nut (40).
- i. Install one washer (24) and bracket (38) on bolt (6). Install nut (22) and secure with cotter pin (21).

j. Ensure that cable (5) is routed as shown in figure 11-21. Install connector (4) on cable (5) in same sequence as original installation (Appendix F and paragraph 9-22).

**11-47. INSTALLATION - GUNNER CYCLIC STICK (AVIM).**

- a. Place stick assembly into opening of console, inserting electrical cable first.
- b. Align stick support to mounting holes of beam. Install three bolts (24, figure 11-20) with thin aluminum alloy washers (25) under heads.
- c. Connect fore-and-aft system tube assembly (13) by installing bolt (15), washers (12 and 14), nut (11), and cotter pin (10).
- d. Connect lateral system link (21) by installing bolt (23), washers (20 and 22), nut (19), and cotter pin (18).
- e. Connect electrical cable connector (9) to receptacle in console.
- f. Secure boot (26) to console with screw (28) and washer (27) on inboard side and screw (28) and washer (27) on outboard side.

**11-48. OPERATIONAL CHECK - GUNNER CYCLIC STICK.**

- a. Check complete control system for security and safetying of components.
- b. Check cyclic system rigging as outlined in paragraph 11-29.
- c. Install access panel.
- d. Perform maintenance test flight (TM 55-1520-236 MTF).

**11-49. JACK SHAFT - CYCLIC CONTROLS.****11-50. DESCRIPTION - JACKSHAFT - CYCLIC CONTROLS.**

The jackshaft integrates fore-and-aft cyclic control input actions from the pilot and gunner cyclic sticks into one output action and changes the direction of

## TM 55-1520-236-23

movement from WL 54.76, station 146.50 down and slightly forward to a bellcrank at WL 37.88, station 144.75. Supports located at stations 146.50 and 148.50 provide for attachment of the jackshaft to the fuselage. The jackshaft rotates on bearings within the supports.

### Premaintenance Requirements for Jackshaft

Conditions	Requirements
Model	AH-1S
Part No. or Serial No.	All
Special Tools	(T48), (T61)
Test Equipment	None
Support Equipment	None
Minimum Personnel Required	One
Consumable Materials	(C31), (C36), (C88), (C91), (C102), (C112)
Special Environmental Conditions	None

### 11-51. REMOVAL - JACKSHAFT - CYCLIC CONTROL.

a. Remove access panels (4,5,9, and 10, figure 2-3) from right side of fuselage and remove access panels (32, 33, and 34) from bottom of fuselage.

b. Open ammunition compartment door (8) and remove access panel on aft, center bulkhead inside ammunition compartment. Detach tube assembly (12, 16, and 19, figure 11-12) and force gradient (14) from levers of jackshaft (15). Refer to paragraph 11-65 for procedure.

c. Remove nut (21, figure 11-22), washers (18 and 20), and bolt (17) that attaches lower ear of support (3) to right hand beam and lower ear of support assembly.

d. Remove bolts (5) and washers (4) from remaining two ears of support (3).

e. Detach jackshaft support (8) from its attaching point by removing four bolts (10) and washers (9).

f. Carefully guide outboard lever of jackshaft (1) through the opening in right hand beam assembly and remove jackshaft from fuselage through ammunition compartment.

g. Remove cotter pin (11), nut (12), washers (13 and 14) and remove support (8) from end of jackshaft.

h. Remove support (3) from bearing surface of jackshaft and guide it off end of jackshaft over lever.

### 11-52. INSPECTION - JACKSHAFT - CYCLIC CONTROLS.

a. Inspect jackshaft assembly (1, figure 11-22) and support assemblies (3 and 8) for cracks, using fluorescent penetrant in accordance with TM 43-0103.

b. Inspect bearings (2, 6, 15, 19, and 22) for roughness, freedom of movement, and wear in excess of **0.005** inch radial and **0.030** inch axial play.

c. Inspect plating on bearing surface of jackshaft for wear, damage, and peeling. Minimum allowable diameter of plated bearing surfaces is **1.560** inch.

d. Inspect plug (7) for damaged threads and worn, peeled or damaged plating.

e. Inspect jackshaft (1) and supports (3 and 8) for scratches and corrosion.

### 11-53. REPAIR OR REPLACEMENT - JACKSHAFT CYCLIC CONTROLS.

a. Polish out all scratches and corrosion on jackshaft (1, figure 11-22) or supports (3 and 8) which do not exceed **0.005** inch depth, using 180 grit or finer sandpaper (C102). Polish to a smooth, scratch free finish with abrasive cloth (C36). Blend edges of repair into surrounding area. Apply chemical film coating (C31) to repaired areas. Prime repaired areas with primer (C88 or C91).

b. Replace jackshaft assembly (1, figure 11-19) or supports (3 and 8) if cracked.

c. Replace bearings (2, 6, and 19) when wear or damage exceeds limits of paragraph 11-52. Refer to paragraph 11-13 for replacement procedure.

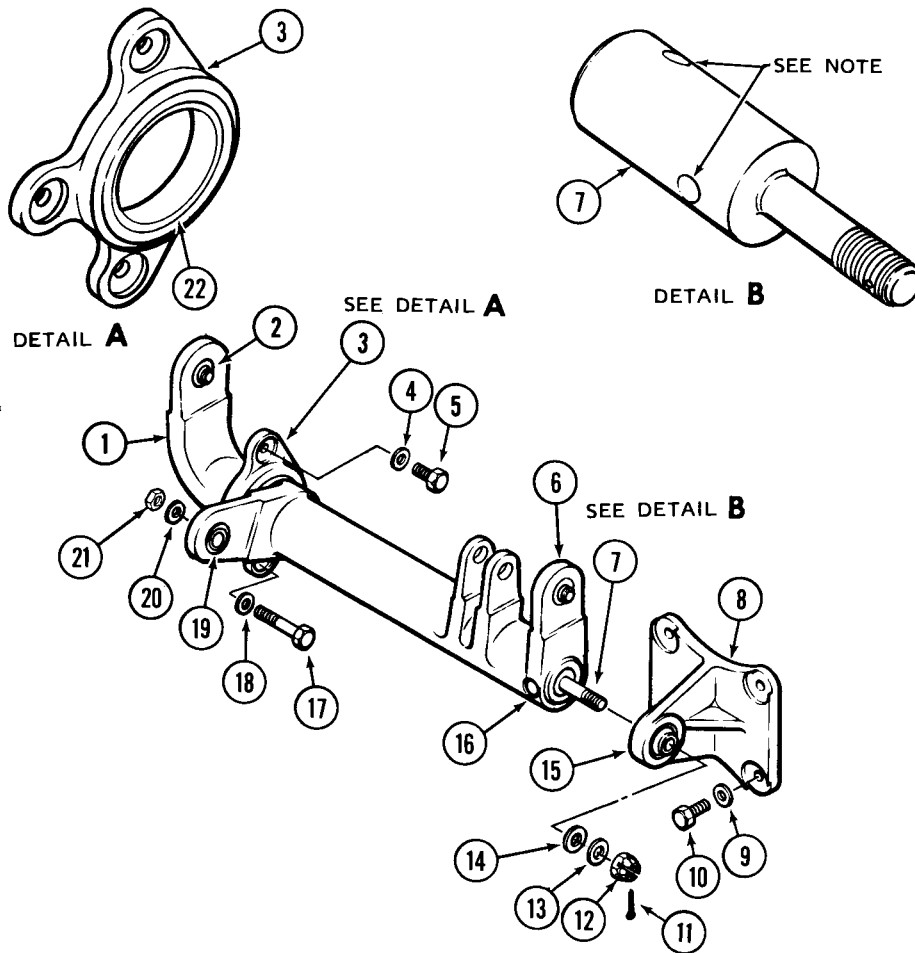

NOTE: Drill two 0.191 TO 0.196 diameter holes to match with holes in jackshaft.

ALL DIMENSIONS ARE IN INCHES UNLESS OTHERWISE NOTED.

- |                     |                |             |
|---------------------|----------------|-------------|
| 1. Jackshaft        | 9. Washer      | 17. Bolt    |
| 2. Bearing          | 10. Bolt       | 18. Washer  |
| 3. Support assembly | 11. Cotter pin | 19. Bearing |
| 4. Washer           | 12. Nut        | 20. Washer  |
| 5. Bolt             | 13. Washer     | 21. Nut     |
| 6. Bearing          | 14. Washer     | 22. Bearing |
| 7. Plug             | 15. Bearing    |             |
| 8. Support          | 16. Rivet      |             |

209001-102A

Figure 11-22. Fore-and-Aft Cyclic Jackshaft Installation

d. Replace bearing (15) in support (8) when wear or damage limits in paragraph 11-52, step b. (Use replacement procedure in paragraph 11-13, except use staking tool (T48) instead of staking tool (T58).

e. Replace bearing (22) in support (3) when wear or damaged exceeds limits in paragraph 11-52.

(1) Carefully press bearing from support.



**Cleaning solvent is flammable and toxic. Provide adequate ventilation. Avoid prolonged breathing of solvent vapors and contact with skin or eyes.**

(2) Clean inside of support with dry cleaning solvent (C112).

(3) Apply primer (C88 or C91) to outer race of bearing.

(4) Carefully press new bearing (22) into support while primer is wet.

f. Replace jackshaft (1) when wear and damage to plated bearing surface is in excess of limits in paragraph 11-52.

g. Inspect plug (7) in end of jackshaft. If inspection reveals any damage, send to next higher maintenance level.

#### 11-54. INSTALLATION - JACKSHAFT - CYCLIC CONTROLS.

a. Install support (3, figure 11-22) on jackshaft (1) and position it on plated bearing surface of jackshaft.

b. Insert threaded end of plug (7) into support (8) bearing. Install two washers (13 and 14), nut (12), and cotter pin (11).

c. Carefully guide outboard lever of jackshaft (1) through opening in right hand beam assembly.

d. Align the three holes in support (3) with holes in right hand beam. Install one bolt (5) with one washer (4) through bolt hole in top and in forward ear of support (3).

e. Install bolt (17) with washer (18) through hole in bottom ear of support (3). Secure with washer (20) and nut (21).

f. Align support (8) to four holes in bulkhead and install four bolts (10), washers (9) under bolt heads.

g. Attach tube assemblies (12, 16, and 19, figure 11-12) and force gradient (14) to levers of jackshaft (15).

h. Check complete control system for security and safetying of components.

i. Check cyclic system rigging (paragraph 11-29).

j. Install access panels, (4,5,9, and 10, figure 2-3) and access panels (32, 33, and 34). Install access panel on aft, center bulkhead inside ammunition compartment and secure ammunition door (8).

k. Perform maintenance test flight (TM 55-1520-236 MTF).

#### 11-55. MAGNETIC BRAKE - CYCLIC CONTROLS.

#### 11-56. DESCRIPTION - MAGNETIC BRAKE - CYCLIC CONTROLS.

A magnetic brake assembly is installed in both the fore-and-aft and lateral cyclic control system. Each brake assembly is secured to the airframe structure. It consists of a rotary shaft which can be mechanically actuated and an electrically actuated magnetic brake that will hold the rotary shaft at any point in its travel when actuated by a switch on the cyclic stick (figures 11-12 and 11-13).

#### Premaintenance Requirements for Magnetic Brake

Conditions	Requirements
Model	AH-1S
Part No. or Serial No.	All
Special TOOLS	None
Test Equipment	None

Conditions	Requirements
Support Equipment	None
Minimum Personnel Required	Two
Consumable Materials	(C88), (C91), (C102), (C112)
Special Environmental Conditions	None

**11-57. INSPECTION - MAGNETIC BRAKE - CYCLIC CONTROL.**

- a. With electrical power off, manually rotate the rotary shaft of the magnetic brake from stop to stop. Check to ensure freedom of rotation and full range of travel.
- b. Apply electrical power to actuate the magnetic brake. Check to ensure that the rotary shaft will not rotate with brake applied.
- c. Check attachment bolts for security, if magnetic brake is attached to the fuselage.
- d. Inspect electrical connector for mechanical damage and corrosion.

**11-58. REMOVAL - MAGNETIC BRAKE - CYCLIC CONTROLS.**

- a. Turn electrical power off.
- b. Remove access panel. For the fore-and-aft system, remove panel in top of ammunition compartment. For lateral system, remove panel on right side of fuselage above ammunition compartment.
- c. Disconnect electrical connector from receptacle on magnetic brake.
- d. Detach force gradient from arm of magnetic brake by removing cotter pin, nut and washer, and from bellcrank by removing cotter pin, nut, washer, and bolt.

e. On lateral system only, unhook springs (29, figure 11-13) from plates (28). Detach plates (28) by removing two bolts.

f. Detach magnetic brake assembly from structure by removing four bolts and washers.



**Cleaning solvent is flammable and toxic. Provide adequate ventilation. Avoid prolonged breathing of solvent vapors and contact with skin or eyes.**

**11-59. CLEANING - MAGNETIC BRAKE - CYCLIC CONTROLS.**

Clean exposed surface of magnetic brake with clean cloth dampened with dry cleaning solvent (C112). Do not allow solvent to enter bearings or electrical components.

**11-60. REPAIR OR REPLACEMENT - MAGNETIC BRAKE - CYCLIC CONTROLS.**

- a. Remove minor corrosion with sandpaper (C102). Prime repaired area with primer (C88 or C91). If corrosion damage is severe enough to affect function, replace the magnetic brake assembly.
- b. Replace magnetic brake assembly if damaged or malfunctioning.

**11-61. INSTALLATION - MAGNETIC BRAKE - CYCLIC CONTROLS.**

- a. Prior to installation of magnetic brake assembly, check the magnetic brake assembly to make sure arm is properly located on the shaft. Mark "F" on the arm must be 90 degrees from line on end of shaft. See detail A, figure 11-12 and detail D, figure 11-13.
- b. Position magnetic brake assembly to mounting holes of structure, and install four attaching bolts with washers.

**NOTE**

**Springs (29, figure 11-13) assist control stick movements by compensating for weight of the actuator (12) and will normally be attached in end holes of plate (28).**

(1) Install magnetic brake (27) for the lateral cyclic system on the outboard side of beam in the right side console at fuselage station 105.78 with the electrical receptacle facing aft and the arm pointing outboard (to right) at midtravel. Install plate (28) on two aft bolts, on outboard side of brake body. Hook springs (29) on plate (28).

(2) Install magnetic brake (17, figure 11-13) for the fore-and-aft cyclic system on the underside of the pilot floor panel inboard of right side beam and aft of pilot control stick at fuselage station 133.76 with the electrical receptacle facing forward and the arm on the inboard side pointing down at midtravel.

c. Connect electrical connector to receptacle on magnetic brake.

d. Install force gradient (paragraph 11-70).

**11-62. FORCE GRADIENT - CYCLIC CONTROLS.**

**11-63. DESCRIPTION - FORCE GRADIENT - CYCLIC CONTROLS.**

A force gradient assembly in each of the two cyclic controls systems performs stick centering and force trim functions. The force gradient is a link equipped with an internal spring and connects the magnetic brake arm to a lever or bellcrank in the cyclic control system (figures 11-12 and 11-13).

**Premaintenance Requirements for Force Gradient in Cyclic Control**

Conditions	REQUIREMENTS
Model	AH-1S
Part No. or Serial No.	All
Special Tools	None
Test Equipment	None
Support Equipment	None
Minimum Personnel Required	Two
Consumable Materials	(C112), (C138)
Special Environmental Conditions	None

**11-64. INSPECTION - FORCE GRADIENT - CYCLIC CONTROLS (AVIM).**

a. Check cap (2, figure 11-23), cylinder (3), and shaft (8) thread condition.

b. Fluorescent penetrant inspect cylinder (3), shaft (8), and guides (9 and 11) in accordance with TM 43-0103, if cracks are suspected. Refer to paragraph 11-67 for disassembly of force gradient.

c. Inspect bearing (4) for binding and/OR FREEDOM OF MOVEMENT\_

**NOTE**

**Free length of spring used in tail rotor force gradient should be 4.50 TO 4.62 inches.**

d. Inspect free length of spring (10) for length of 4.84 to 4.96 inches.

**11-65. REMOVAL - FORCE GRADIENT-CYCLIC CONTROLS.**

a. Remove access panels. Fore-and-aft gradient, remove panel in top of ammunition compartment. For lateral gradient, remove panel on right side of fuselage above ammunition compartment.

b. Detach force gradient from arm of magnetic brake by removing cotter pin, nut, and washer. Detach lateral gradient (21, figure 11-13) from bellcrank or fore-and-aft gradient (14, figure 11-12) from jackshaft by removing cotter pin, nuts, washers, and bolt.



**Cleaning solvent is flammable and toxic. Provide adequate ventilation. Avoid prolonged breathing of solvent vapors and contact with skin or eyes.**



**Do not allow solvent to enter bearings.**

**11-66. CLEANING - FORCE GRADIENT-CYCLIC CONTROLS.**

Clean force gradient components with clean cloth dampened with dry cleaning solvent (C112).



**NOTE**

**Disassembly is only required for fluorescent penetrant inspection or replacement of parts.**

**11-67. DISASSEMBLY - FORCE GRADIENT - CYCLIC CONTROLS (AVIM).**

- a. Cut lockwire and remove cap (2, figure 11-23) from cylinder (3).
- b. Remove spring assembly (1) from cylinder (3).
- c. Remove three nuts (5, 6, and 7) from shaft (8).
- d. Remove spring guides (9 and 11) and spring (10).

**11-68. REPAIR OR REPLACEMENT - FORCE GRADIENT - CYCLIC CONTROLS (AVIM).**

Replace bearing, sleeve, and nuts as necessary.

- a. Fluorescent penetrant inspect housing per MIL-I-6866 (reference TM 55-1500-204-25/1) after bearing removal.
- b. Roll stake sleeve both sides.
- a. Chamfer 0.030 inch depth x 45 degrees each side of hole in housing.
- d. Coat sleeve ID and OD, bearing OD, and housing bore with wet zinc chromate primer (C91) during assembly.

**11-69. ASSEMBLY - FORCE GRADIENT - CYCLIC CONTROLS (AVIM).**

- a. Assemble spring (10, figure 11-23) and guides (9, and 11) on shaft (8) and install one nut (7) onto shaft with edge of nut adjacent to guide (11) on threaded end of shaft.
- b. Preload spring (10) on shaft (8) as follows:
  - (1) Apply a load of **5.5 TO 6.5** pounds on spring of gradient. Measure spring length while at this load, and record length.
  - (2) Tighten nut (7) against guide (11) until length of spring (7) is the same as when under load (step (1) above).

- c. Install nut (6) on shaft (8) adjacent to nut (7).
- d. Hold nut (7) with wrench or other suitable device and tighten nut (6) tightly against it as a jam nut.
- e. Make certain preload on spring is still same as recorded in step b(1).
- f. Insert spring assembly (1) into cylinder (3).
- g. Slide center hole of cap (2) over end of spring shaft (1) with thread end of cap toward cylinder (3).
- h. Screw cap (2) into cylinder (3) until all noticeable end play of spring assembly (1) is removed.
- i. Lockwire cap (2) to cylinder (3) with lockwire (C138) as shown in figure 11-23, to eliminate motion in either direction.
- j. Install remaining nut (5) onto shaft of spring assembly (1) (to be used as jam nut against rod end at installation).

**11-70. INSTALLATION - FORCE GRADIENT - CYCLIC CONTROLS.**

- a. Install rod end on threaded end of spring shaft, with jam nut in place. Final adjustment is made in-rigging procedure.
- b. Connect cylinder end of force gradient assembly on arm of magnetic brake with special washer, nut, and cotter pin. Leave rod end of force gradient disconnected, to be adjusted and connected after rigging cyclic controls.
- c. Attach force gradient assembly (14, figure 11-12) to jackshaft (15). Refer to paragraph 11-29 for rigging instructions of force gradient assembly.
- d. Rig and install force gradient assembly (21, figure 11-13) to bellcrank (19). Refer to paragraph 11-29 for rigging instructions.
- e. After final adjustment, secure rod end (figure 11-13, item 20) with jam nut (figure 11-23, item 5) torqued **150 TO 200** inch-pounds.

**11-71. TAIL ROTOR CONTROL SYSTEM .**

**11-72. DESCRIPTION - TAIL ROTOR CONTROL SYSTEM.**

The tail rotor system consists of two sets of adjustable pedals connected by tube assemblies, bellcranks,

levers, servo actuator (SCAS), magnetic brake and force gradient assembly, and a hydraulic power cylinder which transmits control input from the pedals or SCAS system to the tail rotor tube assembly at tail rotor gearbox (figure 11-24).

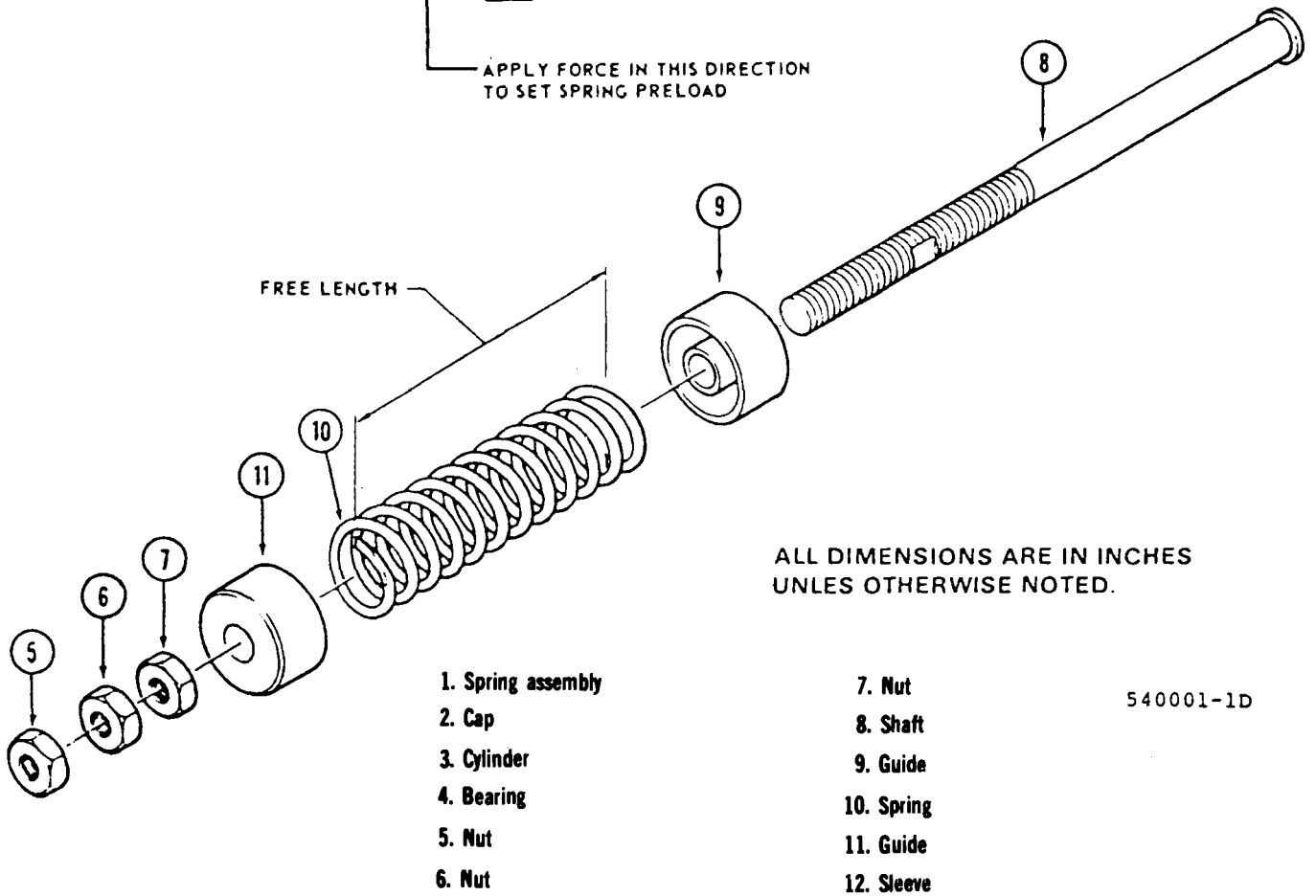
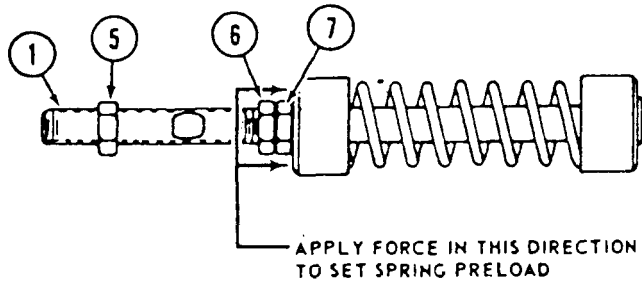
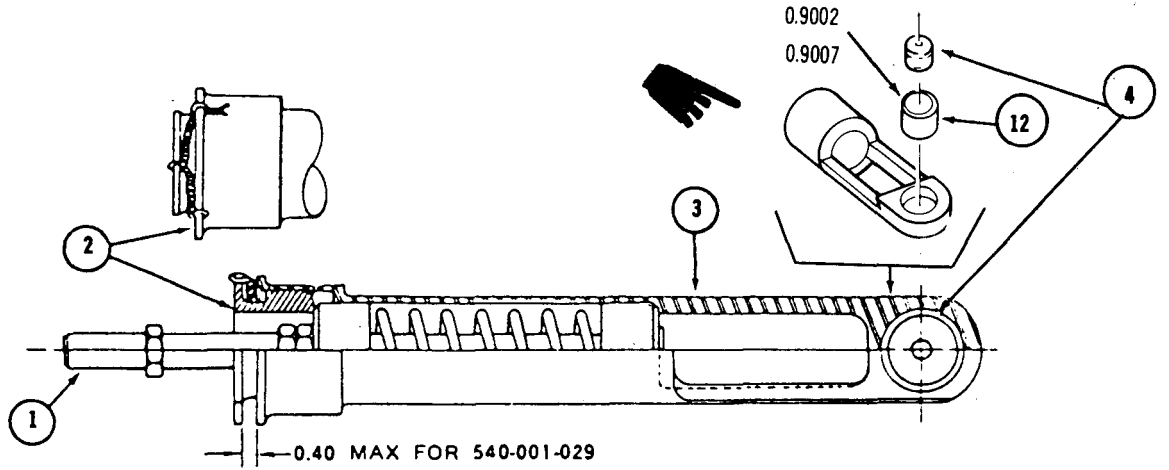

- 1. Spring assembly
- 2. Cap
- 3. Cylinder
- 4. Bearing
- 5. Nut
- 6. Nut

- 7. Nut
- 8. Shaft
- 9. Guide
- 10. Spring
- 11. Guide
- 12. Sleeve

540001-1D

Figure 11-23. Force Gradient Assembly



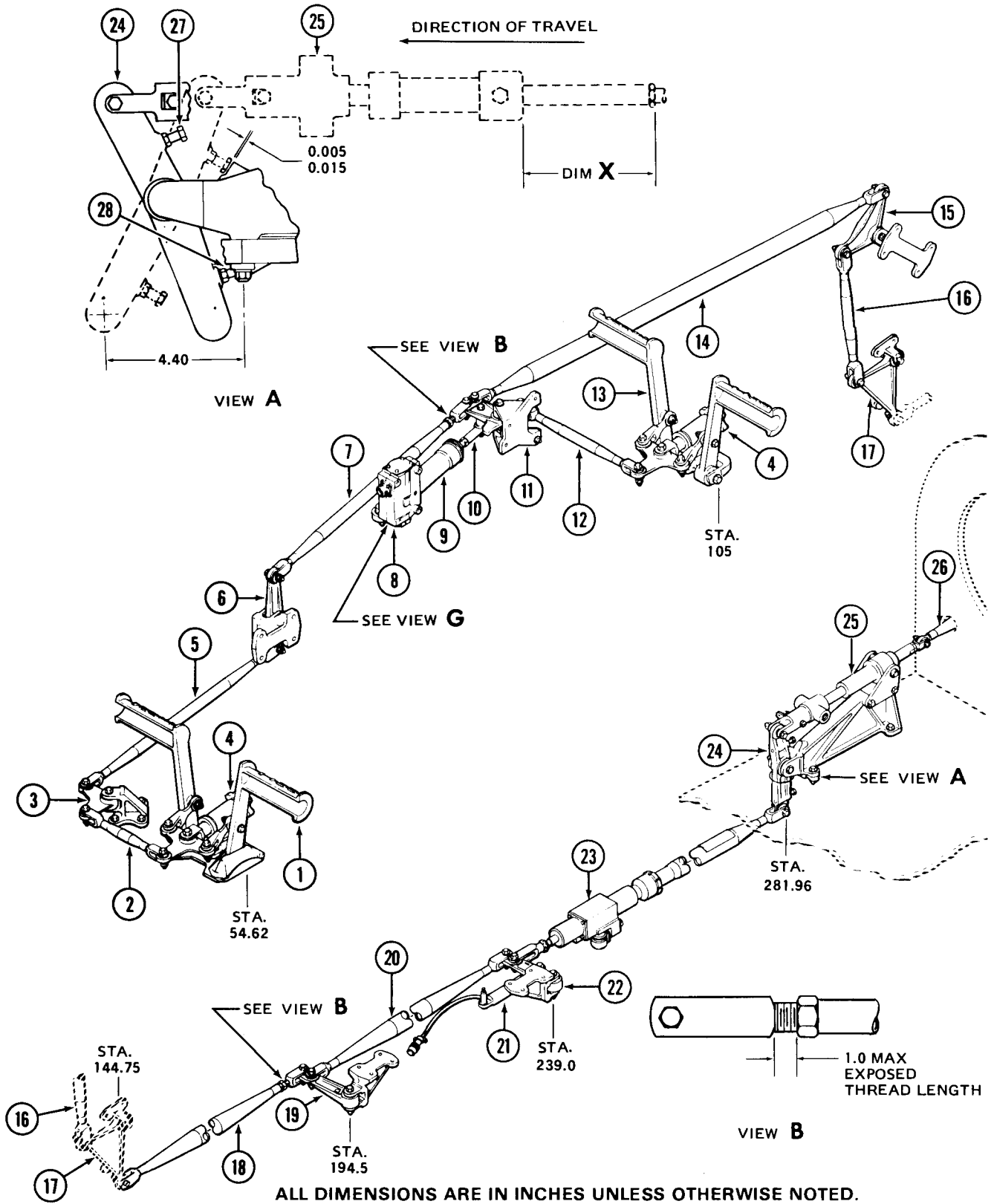

ALL DIMENSIONS ARE IN INCHES UNLESS OTHERWISE NOTED.

209001-110-1A

Figure 11-24. Tail Rotor Controls (Sheet 1 of 3)

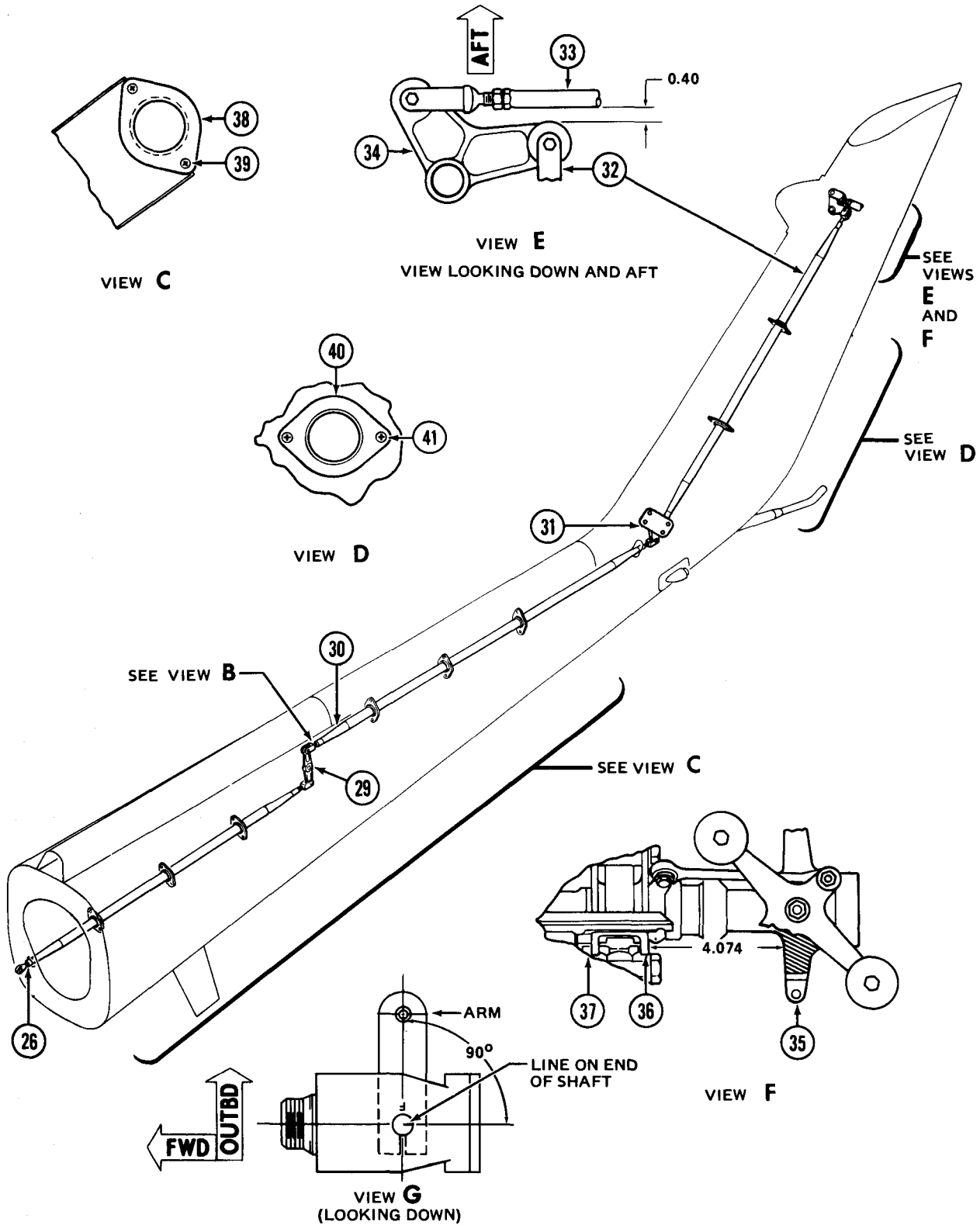

ALL DIMENSIONS ARE IN INCHES UNLESS OTHERWISE NOTED.

209001-110-2A

Figure 11-24. Tail Rotor Controls (Sheet 2 of 3)

- |                           |                                    |
|---------------------------|------------------------------------|
| 1. Gunner control pedals  | 22. Lever                          |
| 2. Tube assembly          | 23. Servo actuator (SCAS)          |
| 3. Bellcrank and support  | 24. Lever                          |
| 4. Adjuster knob          | 25. Hydraulic cylinder and support |
| 5. Tube assembly          | 26. Tube assembly                  |
| 6. Bellcrank assembly     | 27. Top stop bolt                  |
| 7. Tube assembly          | 28. Bottom stop bolt               |
| 8. Magnetic brake         | 29. Lever                          |
| 9. Force gradient         | 30. Tube assembly                  |
| 10. Rod end bearing       | 31. Bellcrank                      |
| 11. Bellcrank and support | 32. Tube assembly                  |
| 12. Tube assembly         | 33. Tube assembly                  |
| 13. Pilot control pedals  | 34. Bellcrank                      |
| 14. Tube assembly         | 35. Crosshead                      |
| 15. Bellcrank             | 36. Trunnion                       |
| 16. Tube assembly         | 37. Tail rotor                     |
| 17. Bellcrank             | 38. Guide                          |
| 18. Tube assembly         | 39. Screw and washer               |
| 19. Lever                 | 40. Guide                          |
| 20. Tube assembly         | 41. Screw and washer               |
| 21. Transducer            |                                    |

209001-110-3A

Figure 11-24. Tail Rotor Controls (Sheet 3 of 3)

**Premaintenance Requirements For  
Tail Rotor Controls**

Conditions	Requirements
Model	AH-1P/E/F
Part No. or Serial No.	All
Special Tools	None
Test Equipment	None
Support Equipment	(S2)
Minimum Personnel Required	Two
Consumable Materials	(C43)
Special Environmental Conditions	N/A

**11-73. RIGGING - TAIL ROTOR CONTROL SYSTEM .**

a. If installed, remove access panels (12, 21, 22, figure 2-2) and access panels (3 and 4 right, 35,45, 53, figure 2-3).

b. Accomplish rigging without hydraulic power unless otherwise stated.

c. Install all fixed length tube assemblies in the anti-torque controls, but do not connect tube assemblies (7, 18, 30, or 33, figure 11-24). Do not connect transducer (21) to lever (22).

d. Adjust pilot and gunner pedals to approximate midposition with adjuster knobs (4).

e. Position pilot pedals even with each other, Position gunner pedals even with each other. Adjust and install tube assembly (7). Coat clevis threads with corrosion preventive compound (C43) when adjusting tube assembly. Ensure that exposed threads on tube (7) do not exceed **1.00** inch as shown on view B.

f. Push right pedal forward against stop. Position lever (24) in position shown in dashed outline in view A. Adjust and install tube assembly (18). Coat clevis threads with corrosion preventive compound (C43) when adjusting tube assembly. Ensure that exposed threads on tube assembly (18) do not exceed 1.00 inch as shown in view B. Check to ensure that right pedal is still forward against stop. Adjust top stop bolt (27) to clear support by **0.005 TO 0.015** inch as shown on detail A.

g. Check to ensure that right pedal is still forward against stop. Push forward on piston rod of hydraulic cylinder (25) to bottom valve. Measure and record dimension X shown on view A. Pivot lever (24) toward position shown by solid outline in view A until dimension X is decreased by **3.02** inches. Keep hydraulic cylinder (25) valve bottomed. Adjust bottom stop bolt (28) to touch stop.

h. Remove tail rotor blade pitch links and adjust to **6.115 ± 0.010** inch dimension. Refer to paragraph 5-104 for instructions to adjust and install tail rotor blade pitch links.

**NOTE**

**Temporarily install tube assembly (30) until left pedal has been pushed forward against stop.**

i. Push left pedal forward against stop and adjust crosshead to **4.074** inch dimensions from outboard face of trunnion as shown in view F. Temporarily disconnect tube assembly (30). Adjust tube assembly (33) to obtain **0.40** inch clearance with bellcrank (34) as shown in view E.

j. Ensure left pedal is still forward against stop. Position bellcrank (34) as noted in preceding step. Push forward on piston rod of hydraulic cylinder (25) to bottom valve. Adjust tube assembly (30) to fit, then lengthen tube by adjusting clevis one turn. Install tube. Ensure that exposed threads on tube (30) do not exceed one inch as shown in view B.

k. Disconnect servo actuator (23) from lever (22). Connect transducer (21) to structure but disconnect from lever (22). Move pilot right pedal full forward against stop. Align transducer (21) for installation on lever and check to ensure that it does not bottom.

i. Move pilot left pedal full forward against stop. Align transducer (21) for installation on lever and check to ensure that it does not bottom. If necessary, adjust rod end on transducer and recheck to ensure

that it does not bottom at either extreme position. Install transducer (21) on lever. Install servo actuator (23) on lever (22).

m. Place pilot control pedals even with each other. Position arm of magnetic brake (8) square within 2 degrees of the beam on which brake is mounted. Adjust force gradient (9) to connect to bellcrank (11) then extend length of rod end by two and one-half turns and install bolt from the top. Use thin aluminum alloy washer under bolt head and standard steel washer under nut. Tighten locknut on rod end.

n. Check complete tail rotor control system for security and safetying of components. Install access panels (12, 21, and 22, figure 2-2, and 35, 45, and 53, figure 2-3).

o. Check operation with hydraulic test stand (S2) if available. If not available, move controls through full throw manually and ensure that there is no binding or interference.

p. Perform tracking check of tail rotor (paragraph 5-115).

**11-74. PEDALS.**

**11-75. DESCRIPTION - PEDALS.**

The pilot and gunner pedal installations are similar. The pedals pivot in support attached beneath the floor. The pedals are connected by short links to a bellcrank mounted on an adjuster which allows variable settings for the comfort and efficiency of crew members. A protective boot covers the openings around the pedals.

**11-76. REMOVAL - PEDALS.**

**NOTE**

**This procedure is the same for both the gunner and pilot tail rotor pedals.**

a. Disconnect tube assembly (1, figure 11-25) from bellcrank (19) at front of pedal assembly by removing cotter pin (18), nut (17), washers (3 and 16) and bolt (2).

b. Disconnect bellcrank links (4 and 23) from pedals (29 and 39) by removing cotter pin (11), nut (12), washers (10 and 40), and bolt (41).

c. Obtain access to area under floor. Remove cotter pin (51), nut (52), washers (45 and 50) and bolt (44) that secure pedals to support (43). Remove pedals upward from support.



d. Remove nuts (46 and 48) and washers (47 and 49) from lower ends of four bolts (31 and 35) that pass through adjuster support (37), boot retainer, floor panel, and pedals support (43). Remove support below floor.



Keep solvent out of bearings.

**Premaintenance Requirements for Pedals**

Conditions	Requirements
Model	AH-1S
Part No. or Serial No.	All
Special Tools	None
Test Equipment	None
Support Equipment	None
Minimum Personnel Required	Two
Consumable Materials	(C30), (C31), (C36), (C43), (C88), (C91), (C102), (C112)
Special Environmental Conditions	None

e. Detach, bellcrank (19) from links (4 and 23) and adjuster clevis (9) by removing bolts (8 and 13), nuts (15 and 27), washers (6, 7, 22 and 25), and cotter pins (14 and 26).

f. If disassembly of adjuster is required, remove nut (34) and retaining washer (33) and unscrew knob (32) from threaded end of clevis (9). Slide clevis out of adjuster support. Handle parts with care to avoid damaging threads and mating surfaces coated with dry film lubricant.



**Cleaning solvent is flammable and toxic. Provide adequate ventilation. Avoid prolonged breathing of solvent vapors and contact with skin or eyes.**

**11-77. CLEANING - PEDALS.**

Clean parts with dry cleaning solvent (C112). Use care to avoid removing solid film lubrication from shank of adjuster clevis and interior surfaces of adjuster knob and housing.

**11-78. INSPECTION - PEDALS.**

a. If cracks are suspected, fluorescent penetrant inspect bellcrank (19, figure 11-25), links (4 and 23), clevis (9), pedals (29 and 39), and supports (37 and 43) in accordance with TM 43-0103.

b. Inspect bearings (5, 20, 21, 28 and 42) for roughness, freedom of movement, and wear in excess of **0.005** inch radial and **0.030** inch axial play.

c. Inspect clevis (9) and bellcrank (19) for corrosion, damaged threads, and elongated holes.

d. Inspect knob (32) for corrosion and damage.

e. Inspect links (4 and 23) for corrosion and worn or elongated bushings.

f. Inspect pedals (29 and 39) and support (37 and 43) for corrosion and elongated holes.

**11-79. REPAIR OR REPLACEMENT - PEDALS.**

a. Replace parts which fail to meet inspection requirements of paragraph 11-78.

b. Polish out all scratches and corrosion that do not exceed **0.005** inch depth, using 180 grit or finer sandpaper (C102). Polish to a smooth, scratch free finish with abrasive cloth (C36). Blend edges of repair into surrounding area. Apply chemical film cpating (C31) to repaired area. Prime repaired areas with primer (C88 or C91).

c. Refer to paragraph 11-13 for procedure to replace bearing (5, 21 and 28, figure 11-25).

d. Replace worn or elongated bushings (24) in links (4 and 23) as follows: (AVIM)

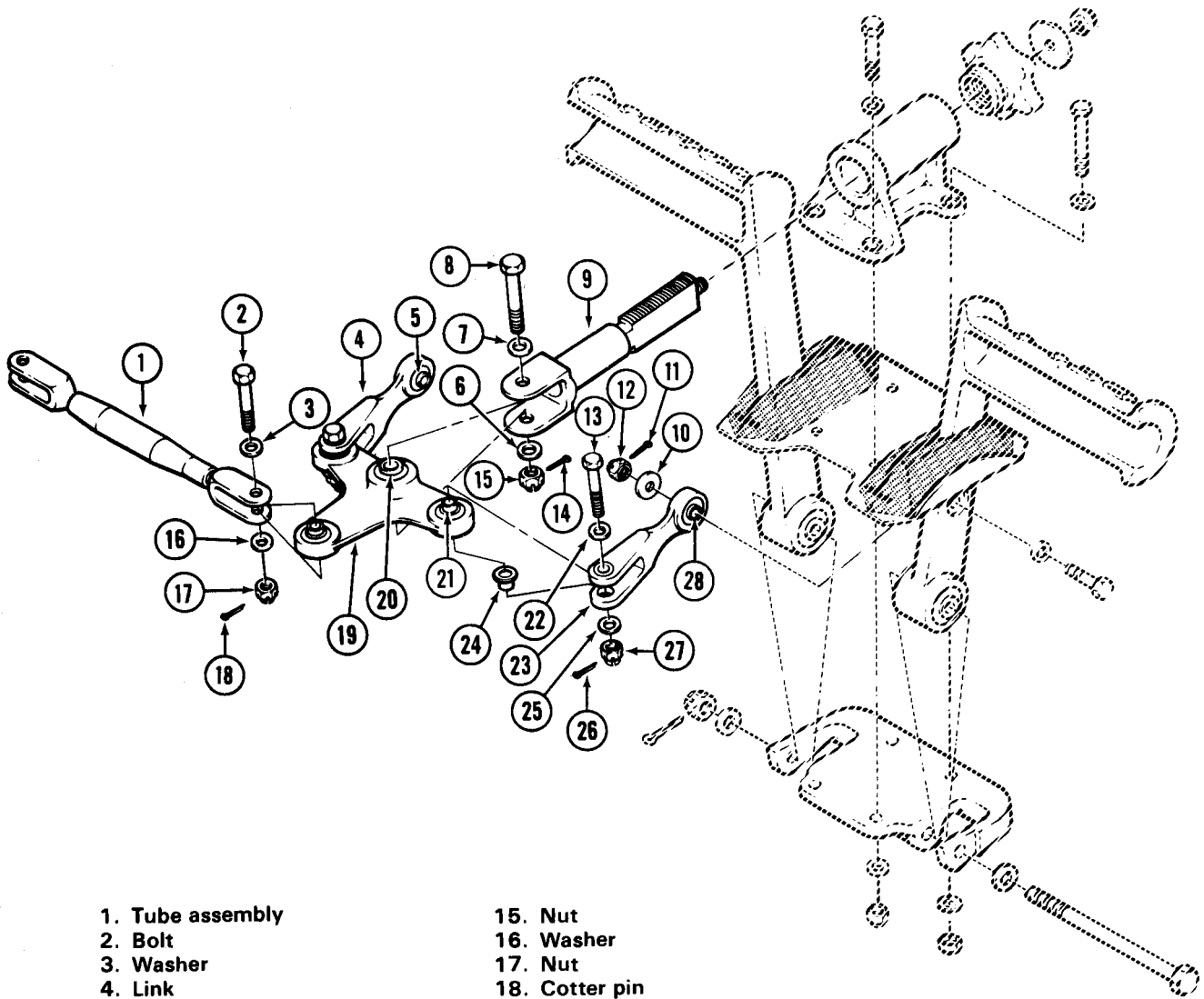

- |                  |                |
|------------------|----------------|
| 1. Tube assembly | 15. Nut        |
| 2. Bolt          | 16. Washer     |
| 3. Washer        | 17. Nut        |
| 4. Link          | 18. Cotter pin |
| 5. Bearing       | 19. Bellcrank  |
| 6. Washer        | 20. Bearing    |
| 7. Washer        | 21. Bearing    |
| 8. Bolt          | 22. Washer     |
| 9. Clevis        | 23. Link       |
| 10. Washer       | 24. Bushing    |
| 11. Cotter pin   | 25. Washer     |
| 12. Nut          | 26. Cotter pin |
| 13. Bolt         | 27. Nut        |
| 14. Cotter pin   | 28. Bearing    |

209001-83-1B

Figure 11-25. Tail Rotor Pedal Installation (Sheet 1 of 2)

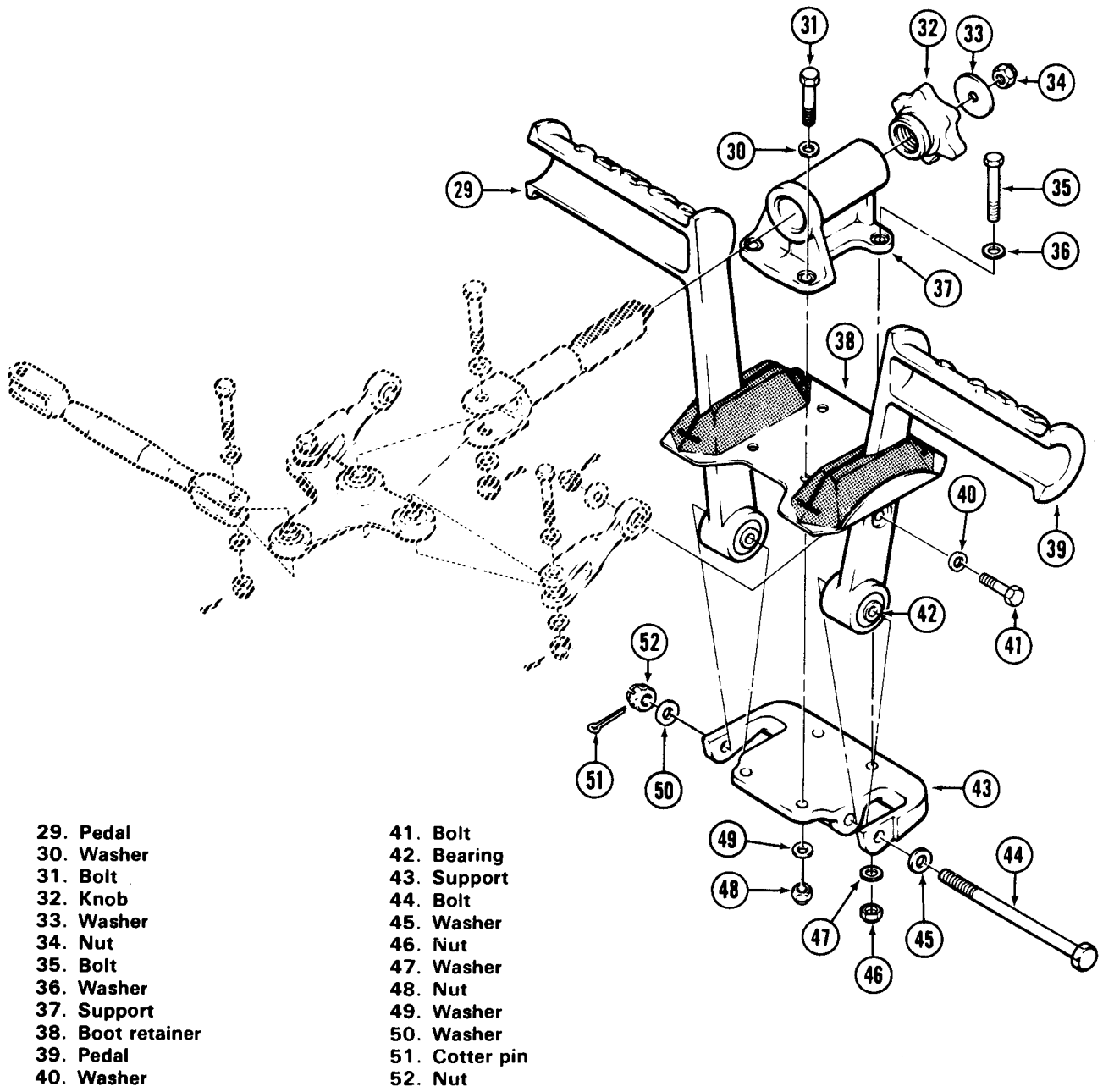

209001-83-2B

Figure 11-25. Tail Rotor Pedal Installation (Sheet 2 of 2)

- (1) Press old bushing from link.



**Cleaning solvent is flammable and toxic. Provide adequate ventilation. Avoid prolonged breathing of solvent vapors and contact with skin or eyes.**

- (2) Clean hole in link with clean cheese cloth (C30) dampened with dry cleaning solvent (C112).

- (3) Prime outer race of bushing with primer (C88 or C91) and press new bushing into link (4 or 23).

- (4) Line ream hole in bushing (24) to **0.2495 TO 0.2505** inch diameter. Polish to a smooth scratch free finish with abrasive cloth (C36).

- e. Replace bellcrank (19) or pedals (29 and 39) when damage to bearings (20 or 42) exceeds limits of paragraph 11-78.

## 11-80. INSTALLATION - PEDALS.

### NOTE

**This procedure is typical for either pilot or gunner pedal and adjuster assemblies.**

- a. Coat clevis threads with lubricant (C43) and insert threaded end of clevis (9, figure 11-25) into adjuster support (37) from flared lower end. Position knob (32) on opposite end, with lip engaged in retaining groove. Screw knob on clevis threads. Install retaining washer (33) and nut (34) on small threaded end.

- b. Align pedal interconnecting bellcrank (19) in adjuster clevis (9). Install bolt (8) from top through clevis and bellcrank. Use aluminum alloy washers (6 and 7) under bolt head and under nut. Secure nut (15) with cotter pin (14). In the same manner, attach two links (4 and 23) to bellcrank, using bolts (13), washers (22 and 25), nut (27) and cotter pin (26).

- c. Position pedal support (43) under floor openings, with open sides of pedal slots forward. Place boot retainer (38) and adjuster assembly over floor openings. Align holes and install two bolts (31)

and two bolts (35) through adjuster support, boot retainer, floor panel, and pedal support. Use one washer (30 and 36) under each bolt head and one washer (47 and 49) under each nut (46 and 48).

- d. Insert pedals (29 and 39) down through boot slots. Align holes in support. Install bolt (44) with one washer (45), from left side through support and both pedals. Install washer (50), nut (52) and cotter pin (51).

- e. Align a link (4 or 23) from bellcrank (19) to inner side of pedal. Place one washer (40) on bolt (41), and insert through pedal and link. Install safety washer (spacer) (10), nut (12), and cotter pin (11) on inboard end of bolt. Attach link to other pedals in the same manner.

- f. Align tube assembly (1) on forward end of bellcrank (19). Install bolt (2), washers (3 and 16), nut (17) and cotter pin (18).

- g. Check installation to ensure that all cotter pins are installed.

## 11-81. OPERATIONAL CHECK - PEDALS.

- a. Adjust the position of pedals by rotating knob (32, figure 11-25) to set a variety of pedal positions. Actuate the pedals in each position through full range of travel and check for freedom of movement and any binding.

- b. Check tail rotor rigging to ensure that rigging had not been disturbed by pedal installation (paragraph 11-73).

## 11-82. MAGNETIC BRAKE - TAIL ROTOR CONTROLS.

## 11-83. DESCRIPTION - MAGNETIC BRAKE - TAIL ROTOR CONTROLS.

A magnetic brake and force gradient assembly are connected to the linkage for force trim and control centering functions. The brake is secured on the right main beam, and has an arm on its rotary shaft which can be braked and held at any point of travel by use of a switch on the cyclic control stick.

**Premaintenance Requirements for  
Magnetic Brake in Tail Rotor  
Control System**



Conditions	Requirements
Model	AH-1S
Part No. or Serial No.	None
Special Tools	None
Test Equipment	None
Support Equipment	None
Minimum Personnel Required	Two
Consumable Materials	(C88), (C91), (C122)
Special Environmental Conditions	None

**Do not allow solvent to enter bearings or electrical components.**

**11-86. CLEANING - MAGNETIC BRAKE - TAIL ROTOR CONTROL.**

Clean exposed surface of magnetic brake with a clean cloth dampened with dry cleaning solvent (C112).

**11-87. REPAIR OR REPLACEMENT - MAGNETIC BRAKE - TAIL ROTOR CONTROLS.**

a. Clean up minor corrosion and touch up with primer (C88 or C91). If corrosion damage is severe enough to affect function, replace the magnetic brake.

b. Replace magnetic brake assembly if damaged or malfunctioning.

**11-88. INSTALLATION - MAGNETIC BRAKE - TAIL ROTOR CONTROLS.**

a. Prior to installation of magnetic brake assembly, check the magnetic brake assembly, check the magnetic brake assembly to make sure the arm is properly located on the shaft. Mark "F" on the arm must be 90 degrees from line on end of shaft (view G, figure 11-24).

b. Position magnetic brake assembly (8) to mounting holes on outboard side of beam, in gunner right side console between walking beam and bellcrank with the electrical receptacle facing forward and arm on lower side pointing outboard (to right) at midtravel. Install four attaching bolts with thin washers.

c. Connect electrical connector to receptacle on magnetic brake (8).

d. Install force gradient (paragraph 11-97).

**11-84. INSPECTION - MAGNETIC BRAKE - TAIL ROTOR CONTROLS.**

Refer to paragraph 11-57.

**11-85. REMOVAL - MAGNETIC BRAKE - TAIL ROTOR CONTROLS.**

a. Turn electrical power off.

a. Remove access panels.

c. Disconnect electrical connector from receptacle on magnetic brake.

d. Detach force gradient (9, figure 11-24) from arm of magnetic brake by removing cotter pin, nut and washers, and from bellcrank (11) by removing cotter pin, nuts, washers, and bolts.

e. Detach magnetic brake (8) assembly from structure by removing four bolts and washers.



**Cleaning solvent is flammable and toxic. Provide adequate ventilation. Avoid prolonged breathing of solvent vapors and contact with skin or eyes.**

**11-89. FORCE GRADIENT - TAIL ROTOR CONTROLS.**

**11-90. DESCRIPTION - FORCE GRADIENT - TAIL ROTOR CONTROLS.**

A force gradient is used in the tail rotor control system for pedal centering and force trim functions. The force gradient is a link equipped with an internal spring and connects the magnetic brake arm to a bellcrank of the tail rotor controls. Although similar in appearance the lateral and fore-and-aft force gradients are different from the tail rotor force gradient and are not interchangeable.

**Premaintenance Requirements for Force Gradient in Tail Rotor Control System**

Conditions	Requirements
Model	AH-1S
Part No. or Serial No.	All
Special Tools	None
Test Equipment	None
Support Equipment	None
Minimum Personnel Required	Two
Consumable Materials	(C138)
Special Environmental Conditions	None

**11-91. INSPECTION - FORCE GRADIENT - TAIL ROTOR CONTROLS.**

Refer to paragraph 11-64.

**11-92. REMOVAL - FORCE GRADIENT - TAIL ROTOR CONTROLS.**

a. Remove access panels as necessary for access to force gradient (9, figure 11-24).

b. Detach force gradient rod end bearing from bellcrank (11) by removing cotter pin, washers, and bolt.

c. Detach force gradient from arm on magnetic brake by removing cotter pin, nut and washer.

**11-93. CLEANING - FORCE GRADIENT - TAIL ROTOR CONTROLS.**

Refer to paragraph 11-66.

**11-94. DISASSEMBLY - FORCE GRADIENT - TAIL ROTOR CONTROLS (AVIM).**

Refer to paragraph 11-67.

**11-95. REPAIR OR REPLACEMENT - FORCE GRADIENT - TAIL ROTOR CONTROLS (AVIM).**

Replace bearing, sleeve, and nuts as necessary.

a. Fluorescent penetrant inspect housing per MIL-I-6866 (reference TM 55-1500-204-25/1) after bearing removal.

b. Roll stake sleeve both sides.

c. Chamfer 0.030 inch depth x 45 degrees each side of hole in housing.

d. Coat sleeve ID and OD, bearing OD, and housing bore with wet zinc chromate primer (C91) during assembly.

**11-96. ASSEMBLY - FORCE GRADIENT - TAIL ROTOR CONTROLS (AVIM).**

a. Assemble spring (10, figure 11-23) and guides (9 and 11) on shaft (8) and install one nut (7) onto shaft with edge of nut adjacent to guide (11) on threaded end of shaft.

b. Preload spring (10) on shaft (8) as follows:

(1) Apply a load of **2.5 TO 3.0** pounds on spring of gradient. Measure spring length while at this load.

(2) Tighten nut (7) against guide (11) until length of spring (10) is the same as when under load (step (1) above).

**c.** Install nut (6) on shaft (8) adjacent to the nut (7) installed.

**d.** Hold first nut (7) with wrench or other suitable device and tighten nut (6) tightly against it as a jamnut.

**e.** Make certain preload on spring is still same as recorded in step b(1).

**f.** Insert spring assembly (1) into cylinder (3).





g. Slide center hole of cap (2) over end of spring shaft (1) with thread end of cap toward cylinder (3).

h. Screw cap (2) into cylinder (3) until all noticeable end play of spring assembly (1) is removed.

i. Lockwire cap (2) to cylinder (3) with wire (C138) as shown in figure 11-23, to eliminate motion in either direction.

j. Install remaining nut (5) onto shaft of spring assembly (1), to be used as jam nut against rod end at installation.

### 11-97. INSTALLATION - FORCE GRADIENT - TAIL ROTOR CONTROLS.

a. Install rod end bearing (10, figure 11-24) in threaded end of spring shaft, with jam nut in place. Final adjustment is made during rigging procedure.

b. Attach force gradient to arm on magnetic brake by installing cotter pin, nut, and washer.

c. Rig and install force gradient to bellcrank (11) (paragraph 11-73).

### 11-98. STABILITY AND CONTROL AUGMENTATION SYSTEM (SCAS).

#### 11-99. **P** DESCRIPTION - STABILITY AND CONTROL AUGMENTATION SYSTEM (SCAS).

The SCAS is a three axis stability and control augmentation system. It is integrated into fore and aft, lateral, and directional (anti-torque) flight controls to improve stability and handling qualities of the helicopter. The system consists of electro-hydraulic servo actuator control tube assemblies, fore-and-aft cyclic, lateral cyclic, and anti-torque, control motion transducers, pitch, roll, and yaw sensor/a amplifier unit, pylon compensator unit, pylon transducer and control panel. The sensor/amplifier unit produces electrical inputs to servo actuators. Servo actuators are installed as series extensible links in appropriate flight controls and provide compensating control motions to augment stability and control of the helicopter. Operation of servo actuators is not felt in pilot controls provided proper control friction is present. Servo actuators are limited to  $\pm 12.5$  percent of the pilot control authority, and center and lock in case of electrical and/or hydraulic failure. SCAS provides a highly damped airframe for external

disturbances yet maintains high quality control/response characteristics for pilot inputs. Rate gyros (located in sensor/amplifier unit) provide electrical signals to airframe damping against external disturbances. A transducer mounted on the transmission tail rotor driveshaft quill (26, figure 11-26) and a bracket on the fifth mount monitors pylon pitch motion. Control motion transducers provide a compensating electrical signal to prevent system from opposing the pilot during maneuvers and to augment control/response characteristics.

#### 11-100. **E M** DESCRIPTION - STABILITY AND CONTROL AUGMENTATION SYSTEM (SCAS).

The SCAS consists of the following: two circuit breakers, a control panel, sensor amplifier unit; three-axis rate sensor (three rate gyros in one unit); three servo actuators; three solenoid-controlled hydraulic valves; and three control motion transducers. The armament compensator unit supplies signals to each sensor amplifier module (SAM) when the guns are fired. All equipment is interconnected with multi conductor cable assemblies for transferring signal data and power within the system. The SCAS receives 28 Vdc power from the essential do bus through the circuit breaker labeled SCAS PWR. When the SCAS is engaged, 28 Vdc power is also supplied by the battery so that loss of power to the essential do bus will not disengage SCAS. AC power is supplied by the 115 Vac essential bus through the circuit breaker labeled SCAS PWR. Hydraulic power is provided to the longitudinal and lateral electrohydraulic servo actuators by the No. 2 hydraulic system while the directional electrohydraulic servo actuator is supplied by the No. 1 hydraulic system. The three servo-actuator assemblies include one control tube attached to one end of each servo-actuator and a clevis attached to the other end. The control tube and clevis provide for the mounting of the servo actuator in series in the helicopter mechanical control systems. The internal piston and shaft of the actuator is hydraulically moved in and out of the actuator case to provide for mechanical displacement of helicopter controls. The internal centering and locking feature provides a solid link in the helicopter control linkage if hydraulic pressure to the actuator is lost or the channel is disengaged. An internal servo hydraulic valve provides for controlling hydraulic pressure to the piston in the proper direction of displacement. Servo actuators are electro-hydraulically operated and receive command signals from sensor amplifier unit

to hydraulically driven helicopter control system. Servo actuators are limited to  $\pm 12.5$  percent of total pilot control authority. Pitch and roll servo actuators control movement of the swashplate with no resultant motion of the cyclic stick as a result of external forces. Yaw servo actuator moves the tail rotor blade pitch angle in same manner as pitch and roll servo actuators move helicopter swashplate. Yaw servo actuator control authority is also limited to  $\pm 12.5$  percent of control authority available to the pilot through control pedals.

**Premaintenance Requirements for SCAS**

Conditions	Requirements
Model	AH-1S
Part No. or Serial No.	All
Special Tools	None
Test Equipment	None
Support Equipment	None
Minimum Personnel Required	One
Consumable Materials	None
Special Environmental Conditions	None

**11-101. TROUBLESHOOTING AND OPERATIONAL CHECK - (SCAS).**

Refer to TM 11-1520-236 series manuals.

**11-102. SENSOR AMPLIFIER UNIT (SCAS).**

**11-103. P DESCRIPTION - SENSOR AMPLIFIER UNIT (SCAS).**

Sensor Amplifier Unit located in pilot compartment left rear is operationally the center of SCAS and contains components and circuitry to implement stabilization of the AH-1S helicopter. Sensor

Amplifier Unit contains rate gyros to sense helicopter rates, power circuits to power other parts of system, and compensating networks and valve drivers to provide command signals to servo actuators. The sensor amplifier unit is housed in a metal case with four holddown attach points. Front of the case contains two pushbutton switches, labeled GYRO TEST and ACTR TEST and a hinged access door held in place by two captive screws. Right side of case contains one fuse and fuseholder, one spare fuse and fuseholder, and one 41 pin connector, for transferring signal data and power within system. The aft wall of case is utilized as a common mount for three rate gyros within case. Rate signal from rate gyro and control position signal, from control motion transducers, and actuator feedback signal are summed and shaped in compensating network to provide desired helicopter control response.

**11-104. E M DESCRIPTION - SENSOR AMPLIFIER UNIT (SCAS).**

The sensor amplifier unit (SAU) contains three sensor amplifier modules (SAM). One SAM is used for each channel (PITCH, ROLL and YAW). They are housed in a metal case with four holddown attach points. The front of each SAM contains two pushbutton switches, labeled RATE TEST and ACTR TEST, and a NULL light. Each SAM is held in place by four captive screws. The switches isolate inputs from the rate gyros and servo actuators in conjunction with the built-in test equipment (BITE). If, after 30 seconds, a NULL lamp is lighted and the light extinguishes when the RATE TEST switch is depressed, a rate gyro or interconnecting wiring may be defective. Similarly, if a NULL lamp is lighted, and depressing the ACTR TEST switch causes the NULL lamp to extinguish, a servo actuator or interconnecting wiring may be defective. When, either No. 1 or No. 2 hydraulic pressure is lost, the No. 1 or No. 2 hydraulic pressure switch will close. This illuminates the No. 1 HYDR PRESS or the No. 2 HYDR PRESS caution light and disengages the sensor amplifier module(s) (YAW or PITCH and ROLL) relay(s) circuit, thus disengaging the affected channel servo actuator.

**NOTE**

**Refer to TM 11-1520-236 series manuals for removal, troubleshooting, testing and replacement of sensor amplifier unit.**

**11-105. P INSPECTION - SENSOR AMPLIFIER UNIT (SCAS).**

Inspect sensor amplifier, (4, figure 11-26) for the following conditions.

- a. Loose mounting (loose mounting screws and insufficient electrical bonding).
- b. Loose control channel assemblies.
- c. Loose or inoperative NO-GO indicator lights.
- d. Burned fuse.
- e. Account for spare fuse.
- f. Loose or corroded module mounts.
- g. Corroded or damaged connectors, internal or external.

**11-106. EM INSPECTION - SENSOR AMPLIFIER UNIT (SCAS).**

Inspect sensor amplifier (4, figure 11-27) for the following conditions:

- a. Loose mounting (loose mounting screws and insufficient electrical bonding).
- b. Loose control channel assemblies.
- c. Loose or inoperative NO-GO indicator lights.
- d. Loose or corroded module mounts
- e. Corroded or damaged connectors, internal or external.

**11-107. REPAIR OR REPLACEMENT - SENSOR AMPLIFIER UNIT (SCAS) (AVIM).**

- a. Tighten loose mounting screws or bolts.
- b. Replace damaged parts. Refer to TM 11-1520-236 series manuals.

**11-108. P PYLON COMPENSATION UNIT (SCAS).**

**11-109. P DESCRIPTION - PYLON COMPENSATION UNIT (SCAS).**

The pylon compensation unit (PCU) (3, figure 11-26) is located aft and above SCAS sensor amplifier unit. Only 28 Vdc is supplied to the unit from SCAS control panel. The Pylon Compensation Unit electrically detects motion of the pylon with respect to the airframe, and operates in conjunction with SCAS to provide automatic damping. Under certain conditions of power loading, g-loading and velocity, it is possible to set up a low frequency oscillation which causes the pylon to lean or rock in a circular pattern opposite to the direction of rotor rotation. The Pylon Compensation Unit consists of a compensation network and one pylon motion transducer. The transducer measures fore and aft pylon motion relative to the airframe. The compensation network provides necessary signal shaping and phasing to apply corrective signals to the roll channel of SCAS, effectively damping the pylon suspension system to cancel undesired motion.

**NOTE**

Refer to TM 11-1520-236 series manuals for removal and installation of pylon compensation unit.

**11-110. P INSPECTION - PYLON COMPENSATION UNIT (SCAS).**

Inspect the pylon compensation unit (3, figure 11-26) for the following:

- a. Loose mounting or bonding.
- b. Damaged or corroded connectors.
- c. Case damage.
- d. Proper operation. Refer to TM 11-1520-236 series manuals for procedure.

**11-111. P REPAIR OR REPLACEMENT-PYLON COMPENSATION UNIT (SCAS).**

- a. Tighten loose connections.
- b. Replace damaged parts. Refer to TM 11-1520-236 series manuals.

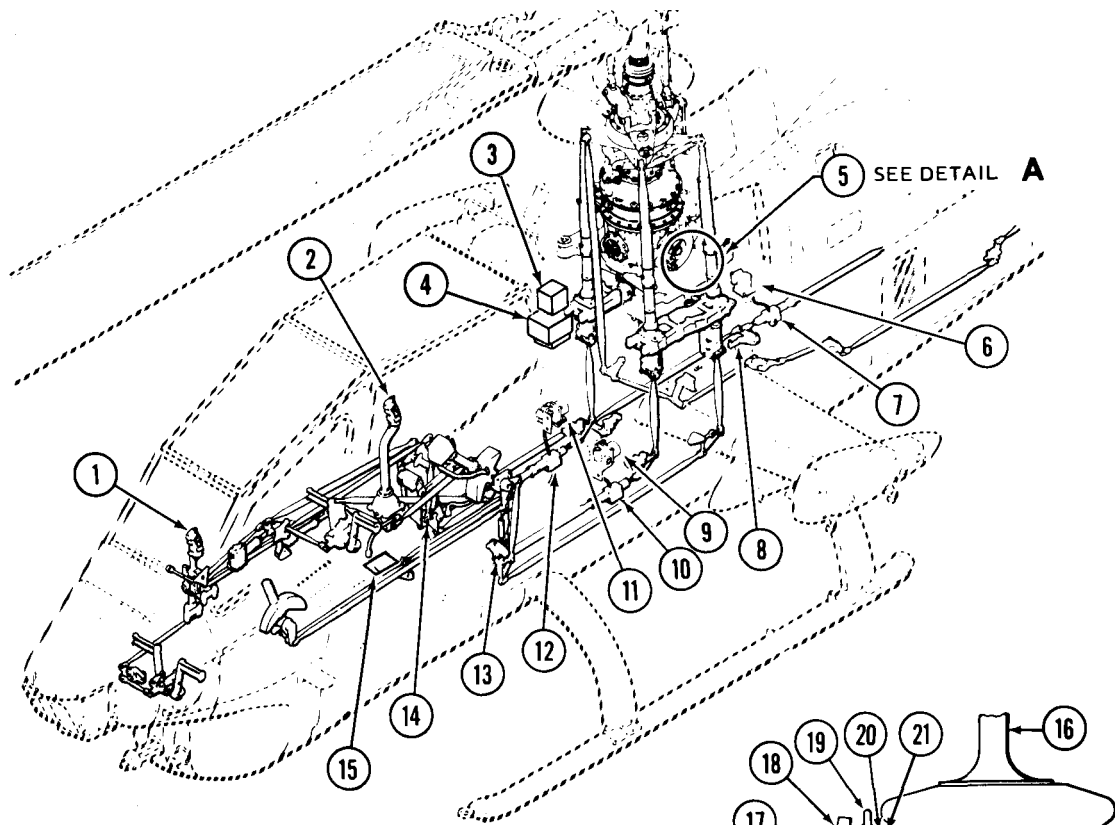

1. Gunner SCAS release switch
2. Pilot SCAS release switch
3. Pylon compensation unit
4. Sensor amplifier unit (SCAS)
5. Pylon transducer
6. Yaw hydraulic solenoid valve
7. Yaw servo actuator (anti-torque)
8. Yaw control motion transducer
9. Roll hydraulic solenoid valve
10. Roll servo actuator (lateral cyclic)
11. Pitch hydraulic solenoid valve
12. Pitch servo actuator (fore and aft cyclic)
13. Roll control motion transducer
14. Pitch control motion transducer
15. SCAS control panel

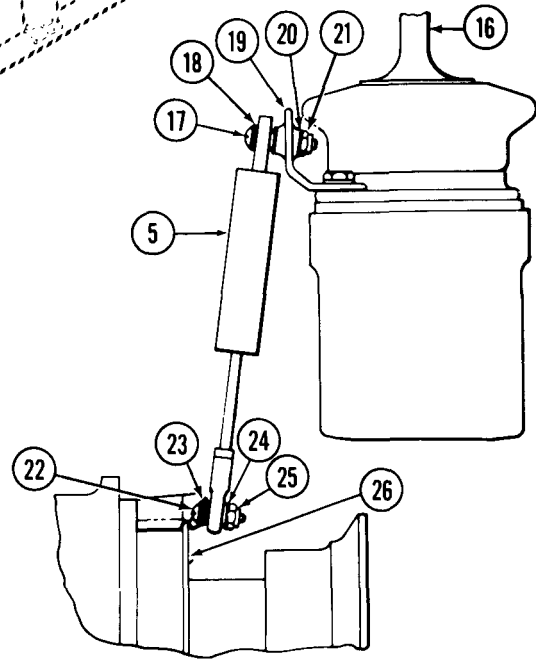

DETAIL A

Figure 11-26. **P** Stability and Control Augmentation System (SCAS)

574074-15E

**11-112. E M ARMAMENT COMPENSATION UNIT (SCAS).**

**11-113. E M DESCRIPTION - ARMAMENT COMPENSATION UNIT (SCAS).**

The armament compensation unit (ACU) (3, figure 11-27) is located in the left side of fuselage forward of the wing. When the weapon is fired, three-axis turret position signals are applied to the ACU to provide weapon recoil damping of helicopter movement. The armament compensation unit electrically interfaces the turret system with the Stability and Control Augmentation System (SCAS). Turret position

signals are applied to the armament compensation unit and, when the M197 gun is fired, output signals are applied to the SCAS servo actuators to provide recoil damping. **E M** The ACU receives 115 Vac power from the RECOIL COMP switch located on the pilot armament control panel. The magnitude of the ACU output signals can be set to either LO-MED-HI by using the RECOIL COMPEN selector switch located on the right side of the pilot instrument panel.

**NOTE**

**Refer to TM 11-1520-236 series manuals for removal and installation of armament compensation unit.**

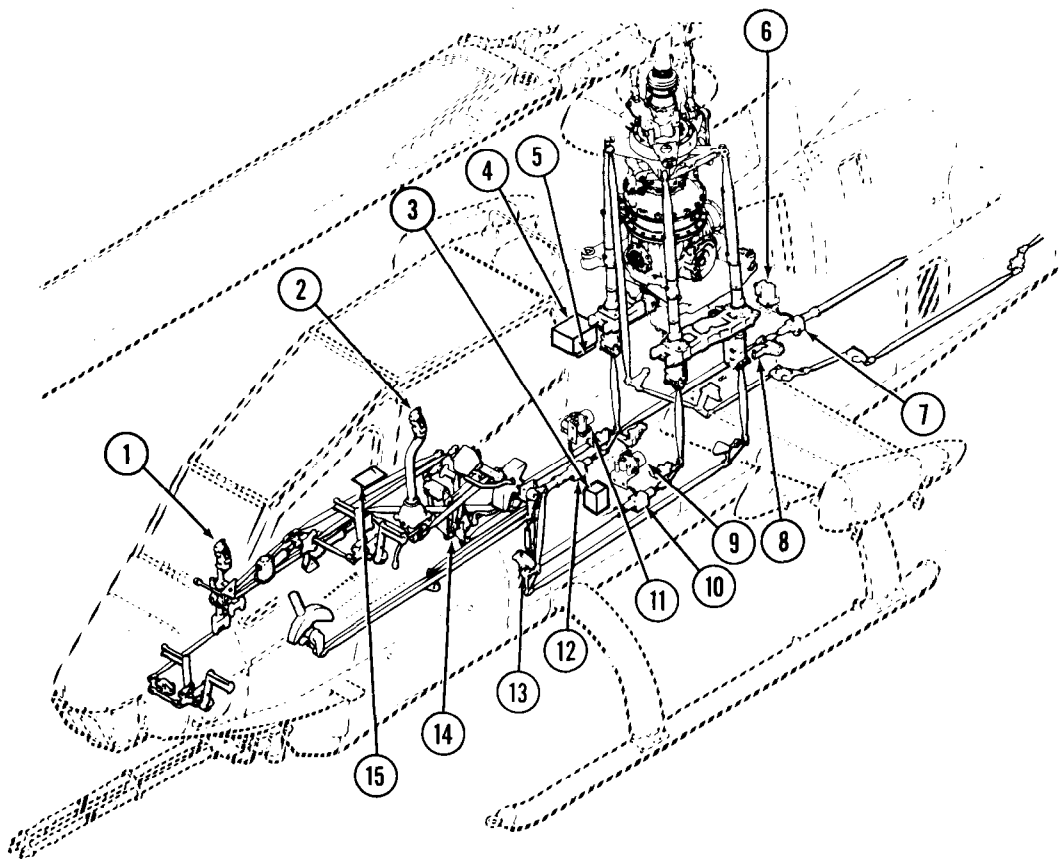

- |  |   |
|--|---|
| <ul style="list-style-type: none"> <li>1. Gunner SCAS release switch</li> <li>2. Pilot SCAS release switch</li> <li>3. Armament compensation unit</li> <li>4. Sensor amplifier unit (SCAS)</li> <li>5. Three-axis rate sensor</li> <li>6. Yaw hydraulic solenoid valve</li> <li>7. Yaw servo actuator (anti-torque)</li> <li>8. Yaw control motion transducer</li> </ul> | <ul style="list-style-type: none"> <li>9. Roll hydraulic solenoid valve</li> <li>10. Roll servo actuator (lateral cyclic)</li> <li>11. Pitch hydraulic solenoid valve</li> <li>12. Pitch servo actuator (fore-and-aft cyclic)</li> <li>13. Roll control motion transducer</li> <li>14. Pitch control motion transducer</li> <li>15. SCAS control panel</li> </ul> |
|--|---|

209001-170

**Figure 11-27. E M Stability and Control Augmentation System (SCAS)**

**11-114. E M INSPECTION - ARMAMENT COMPENSATION UNIT (SCAS).**

Inspect the armament compensation unit for the following:

- a. Loose mounting or bonding.
- b. **E M** Damaged or corroded connectors.
- c. Case damage.
- d. Proper operation. Refer to TM 11-1520-236 series manuals for procedure.

**11-115. E M REPAIR OR REPLACEMENT ARMAMENT COMPENSATION UNIT (SCAS).**

- a. Tighten loose connections.
- b. Replace damaged parts. (Refer to TM 11-1520-236 series manuals.

**11-116. E M THREE-AXIS RATE SENSOR (SCAS).**

**11-117. DESCRIPTION - THREE-AXIS RATE SENSOR.**

Three-axis rate sensor (5, figure 11-27) consists of a mounting surface and holes for four hold-down screws, one cable assembly, and one connector. Three rate gyros within the package sense helicopter rates in each of the three stabilized axis. Electrical rate signal outputs from each of the rate gyros are applied to each of the sensor amplifier modules compensation and logic networks.

**NOTE**

Refer to TM 11-1520-236 series manuals for removal and installation of three-axis rate sensor.

**11-118. INSPECTION - THREE-AXIS RATE SENSOR (SCAS).**

Inspect the three-axis rate sensor (5, figure 11-27), for the following:

- a. Loose mounting or bonding.

- b. Damaged or corroded connectors.

- c. Case damage.

- d. Proper operation. Refer to TM 11-1520-236 series manuals for procedure.

**11-119. E M REPAIR OR REPLACEMENT - THREE-AXIS RATE SENSOR (SCAS).**

- a. Tighten loose connections.

- b. Replace damaged parts. Refer to TM 11-1520-236 series manuals.

**11-120. CONTROL MOTION TRANSDUCER (SCAS).**

**11-121. DESCRIPTION - CONTROL MOTION TRANSDUCER (SCAS).**

Each control channel (pitch, roll and yaw) receives signals from an individual transducer. The signal is processed and summed with rate signals from rate gyros to provide correction signals for instantaneous control of helicopter motion. Transducer signals are one source of control of servo actuators which allow pilot to "fly" system with less effort and provide helicopter flight stabilization. Control motion transducer consists of an internal linear potentiometer, a cylindrical case, a movable shaft, two attach points (one on case and one on shaft), and an electrical connector for transferring signal data to the sensor amp unit.

**11-122. REMOVAL - CONTROL MOTION TRANSDUCER (SCAS).**

- a. Turn all electrical power off.

- b. Remove access panels.

c. Disconnect electrical connector from fore-and-aft (pitch), lateral (roll), or directional (yaw) transducer (8, 13 or 14, figure 11-26 or 11-27). Detach cylinder or transducer from fuselage structure by removing bolt, washer, spacer, and washer. Detach adjustable rod end from bellcrank by removing nut, washers, and screw.

### 11-123. INSPECTION - CONTROL MOTION TRANSDUCER (SCAS).

Inspect control motion transducers as follows:

- a. Bearings for binding corrosion and wear in excess of **0.005** inch radial and **0.030** inch axial play.
- b. Attachment for security.
- c. Electrical connector for condition.
- d. Threads for damage.

#### 11-123.1. CALIBRATION - CONTROL MOTION TRANSDUCER (SCAS).

Calibrate the SCAS transducer as follows:

- a. Disconnect the transducer from the aircraft wiring and airframe.
- b. Support the transducer in order to measure the position of the output shaft length per figure 11-27.1.
- c. Using multimeter (T-2 or T-3), measure the resistance across pins A and B.
- d. The resistance (OHMS) at output shaft positions 1, 2 and 3 must be within the tolerance specified in figure 11-27.1.

### 11-124. REPAIR OR REPLACEMENT - CONTROL MOTION TRANSDUCER (SCAS).

- a. Replace adjustable rod end when worn or binding. Nominal length of transducer in neutral position measured between centers of cylinder bearing and rod end bearing should be **6.18** inch.
- b. Tighten loose attachments.
- c. Replace transducer with damage in excess of that listed in paragraph 11-123.

### 11-125. INSTALLATION-CONTROL MOTION TRANSDUCER (SCAS).

- a. Install pitch control motion transducer (13, figure 11-12).
  - (1) Align pitch control motion transducer cylinder housing bearing to fuselage structure with electrical wire inboard.

- (2) Position stainless steel washer on bait. Install bolt with washer through the rod end bearing, then slide spacer and washer on bolt. Align bolt to outboard side of bellcrank; then secure with bolt and nut.

#### NOTE

**Attach rod end to bellcrank only after completion of rigging. (Refer to paragraph 11-29).**

- (3) Position stainless steel washer on screw. Position cylinder bearing on inboard side of bracket at fuselage. Position washer between bracket and bearing. Then install screw with washer and tighten.

- b. Install roll control motion transducer (15, figure 11-13).

- (1) Align roll control motion transducer cylinder housing bearing to fuselage structure with electrical wire inboard.

- (2) Position stainless steel washer on bolt. Install bolt with washer through the rod end bearing, then slide spacer and washer on bolt. Align bolt to outboard side of bellcrank; then secure with bolt and nut.

#### NOTE

**Attach rod end to bellcrank only after completion of rigging (paragraph 11-29).**

- (3) Position stainless steel washer on screw. Position cylinder bearing on inboard side of bracket at fuselage. Position washer between bracket and bearing. Then install screw with washer and tighten.

- c. Install yaw control motion transducer (21, figure 11-24).

- (1) Align yaw control motion transducer cylinder housing bearing to fuselage structure.

- (2) Position stainless steel washer on bolt. Install bolt with washer through the rod end bearing, then slide spacer and washer on bolt. Align bolt to outboard side of bellcrank; then secure with bolt and nut.

**NOTE**

Attach rod end to directional bellcrank only after completion of rigging (paragraph 11-73).

(3) Position stainless steel washer on screw. Position cylinder bearing on inboard side of bracket at fuselage. Position washer between bracket and bearing. Then install screw with washer and tighten.

**11-126. TEST PROCEDURE - CONTROL MOTION TRANSDUCER (SCAS).**

Refer to TM 11-1520-236 series manuals.

**11-127. P PYLON TRANSDUCER (SCAS).**

**11-128. P DESCRIPTION - PYLON TRANSDUCER (SCAS).**

Pylon transducer (5, figure 11-26) is located between pylon fifth mount and transmission tail rotor driveshaft quill as shown in figure 11-24. The transducer senses pitch motion of pylon. Output signals of transducer are inserted into pylon compensation unit where signals are summed, shaped, attenuated, and inserted into the roll channel of sensor amplifier for retardation of pylon oscillation.

**11-129. P REMOVAL - PYLON TRANSDUCER (SCAS).**

- a. Turn electrical power off.
- b. Gain access to transmission.
- c. Disconnect transducer plug and protect with cover.
- d. Disconnect transducer (5, figure 11-26) from transmission tail rotor driveshaft quill (26), by removing screw (22), washers (23 and 24), and nut (25).
- e. Disconnect transducer (5) from bracket (19) on fifth mount (16) by removing screw (17), washers (18 and 20) and nut (21). Remove transducer.

**NOTE**

For inspection and repair procedures, refer to paragraph 11-123 and 11-124.

**11-130. P INSTALLATION - PYLON TRANSDUCER (SCAS).**

Install transducer (5, figure 11-26) on bracket (19), using screw (17), washers (18 and 20) and nut (21).

b. Install transducer (5) on transmission tail rotor driveshaft quill (26), using screw (22), washers (23 and 24), and nut (25).

c. Remove covers from transducer plug and receptacles. Engage and secure connector.

d. Close and secure transmission cowling.

**11-131. SOLENOID VALVE (SCAS).**

**11-132. DESCRIPTION - SOLENOID VALVES (SCAS).**

The three solenoid valves are two position valves which control hydraulic pressure to servo actuators. In de-energized position, there is not hydraulic pressure, and servo actuators are mechanically locked in center position. When solenoid valve is energized from the SCAS pitch, roll or yaw engage switch, hydraulic pressure is applied to servo actuator to unlock actuator and move actuator piston in response to command signals. Solenoid valve consists of metal case, three hydraulic ports (labeled CYL, RET, and PRESS) to provide for hydraulic connection to helicopter hydraulic system and servo actuators in the SCAS. Two attach points are provided for installation on helicopter structure. One 6 pin electrical connector is attached to case to provide electrical connection to system.

**NOTE**

Refer to paragraph 7-68 for removal, inspection, and installation procedures for SCAS hydraulic solenoid valves.

**11-133. CONTROL PANEL (SCAS).**

**11-134. DESCRIPTION - CONTROL PANEL (SCAS).**

The SCAS control panel (15, figures 11-26 and 11-27) contains a POWER switch for applying 28 Vdc (essential bus) and 115 Vac operating voltages to the system. The circuits are protected by the SCAS PWR



dc and SCAS PWR ac circuit breakers. The panel also contains three channel engage switches which energize electric solenoid valves controlling hydraulic pressure to the system. The panel has three NO-GO lights; one associated with each PITCH, ROLL, and YAW channel engage switch. These lights are illuminated during the warmup to indicate the presence of current in each associated channel actuators. When engagement is made, the NO-GO lights are locked out of the circuit and do not operate as malfunction indicators. Disengaging a channel, however, restores the associated light to operation.

The NO-GO lights have a built-in press-to-test feature for ensuring that the indicator is operational.

**P** This feature works only prior to channel engagement.

#### NOTE

**Refer to TM 11-1520-236 series manuals for removal, repair, and installation procedures.**

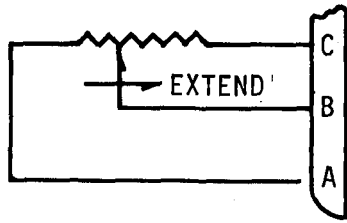

**SCHEMATIC**

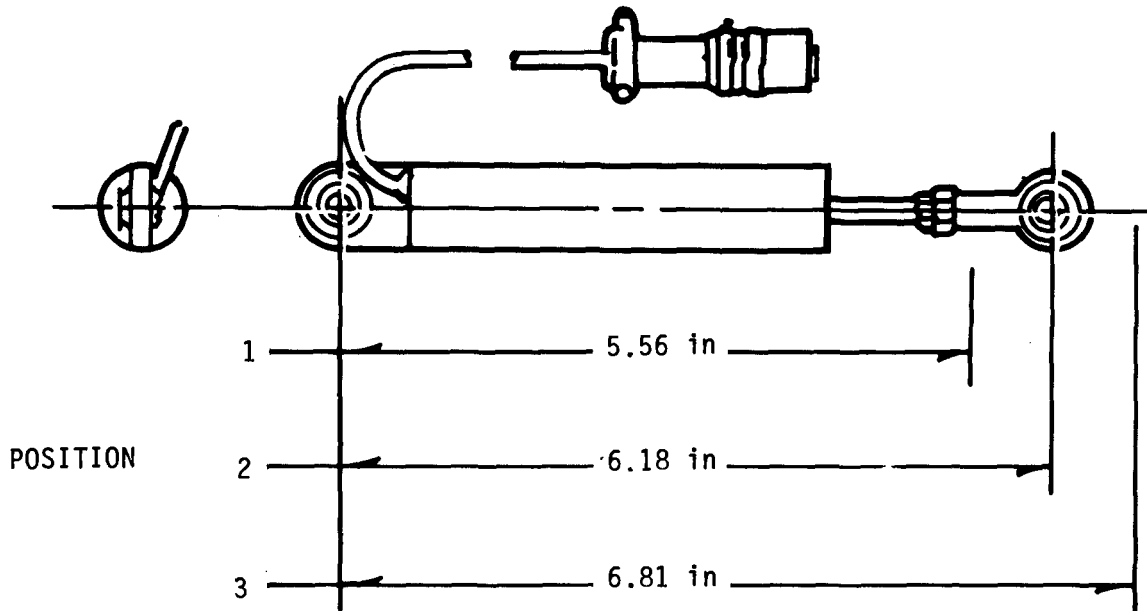

POSITION	FROM PINS	RESISTANCE (OHMS)	TOLERANCE (OHMS)
1	B TO C	1000	±100
2	B TO C	500	±50
3	B TO C	0	±10
Any Position	A TO C	1000	±100

**NOTES:**

1. Extend and retract transducer and observe the resistance reading. Resistance should vary between 0.1000 ohms smoothly without any intermittent or erratic readings.

2. Nominal length of transducer neutral position should be adjusted to 6.18 inches prior to making resistance checks in positions 1, 2 and 3. (Refer to paragraph 11-124a.)

Figure 11-27.1. SCAS TRANSDUCER CALIBRATION

**11-135. INSPECTION - CONTROL PANEL (SCAS).**

- a. Inspect control panel for security.
- b. With electrical power ON, check control panel for the following:
  - (1) Indicator lights for operation.
  - (2) Switches for security and proper operation.

**11-136. ELEVATOR CONTROL SYSTEM.**

**11-137. DESCRIPTION - ELEVATOR CONTROL SYSTEM.**

The elevator control system consists of two elevator assemblies, a horn assembly and a mechanical control linkage of tube assemblies and bellcranks connected in series from the right forward swashplate horn to the elevator horn. Movement of the cyclic control stick in the fore and aft direction actuates the swashplate. This movement is transmitted through the elevator control linkage and changes the angle of attack of the elevator assemblies (figure 11-28).

**Premaintenance Requirements for Elevator Control System Rigging**

Conditions	Requirements
Model	AH-1S
Part No. or Serial No.	All
Special Tools	None
Test Equipment	None
Support Equipment	(S2)
Minimum Personnel Required	Two
Consumable Materials	None
Special Environmental Conditions	None

**11-138. RIGGING - ELEVATOR CONTROL SYSTEM.**

a. Rig cyclic controls if not previously accomplished (paragraph 11-29).

b. If installed, remove right side access (9, figure 2-3) and tailboom access door (21, figure 2-2). Install all components of the elevator control system, but leave tube assembly (18, figure 11-28) disconnected from swashplate inner ring (20), and tube (7) disconnected from elevator horn. Support tube assembly (18) so that control linkage can be moved during rigging procedure.

c. Adjust and attach tube assembly (7) as follows:

(1) Position elevator with trailing edge up so that there is 0.055 to 0.065 inch clearance between forward side of stop (4) and stop (3) on horn (detail C, figure 11-28).

(2) Pull tube assembly (7) to its extreme aft position. Ensure that bellcrank (12) is dead centered with control tube (11).

(3) Adjust length of control tube (7) to fit arm on elevator horn and attach. Do not exceed 1.0 inch exposed thread (detail B, figure 11-28).

d. Adjust and attach tube assembly (18) as follows:

(1) Hold pilot cyclic stick full forward against stop.

(2) Position elevator with trailing edge down so that there is a **0.055 TO 0.065** inch clearance between aft side of stop (4) and stop (3) on horn, (detail C, figure 11-28).

(3) Adjust length of tube assembly (18) to fit on bolt at inboard side of right forward horn of swashplate inner ring (20), then lengthen tube assembly (18) by one turn of rod end to compensate for hydraulic valve position.

(4) Ensure that not more than one inch of thread is exposed at rod end (detail A, figure 11-28). Attach control tube bolt on horn of swashplate inner ring (20).

e. Check rigging with hydraulic boost on.

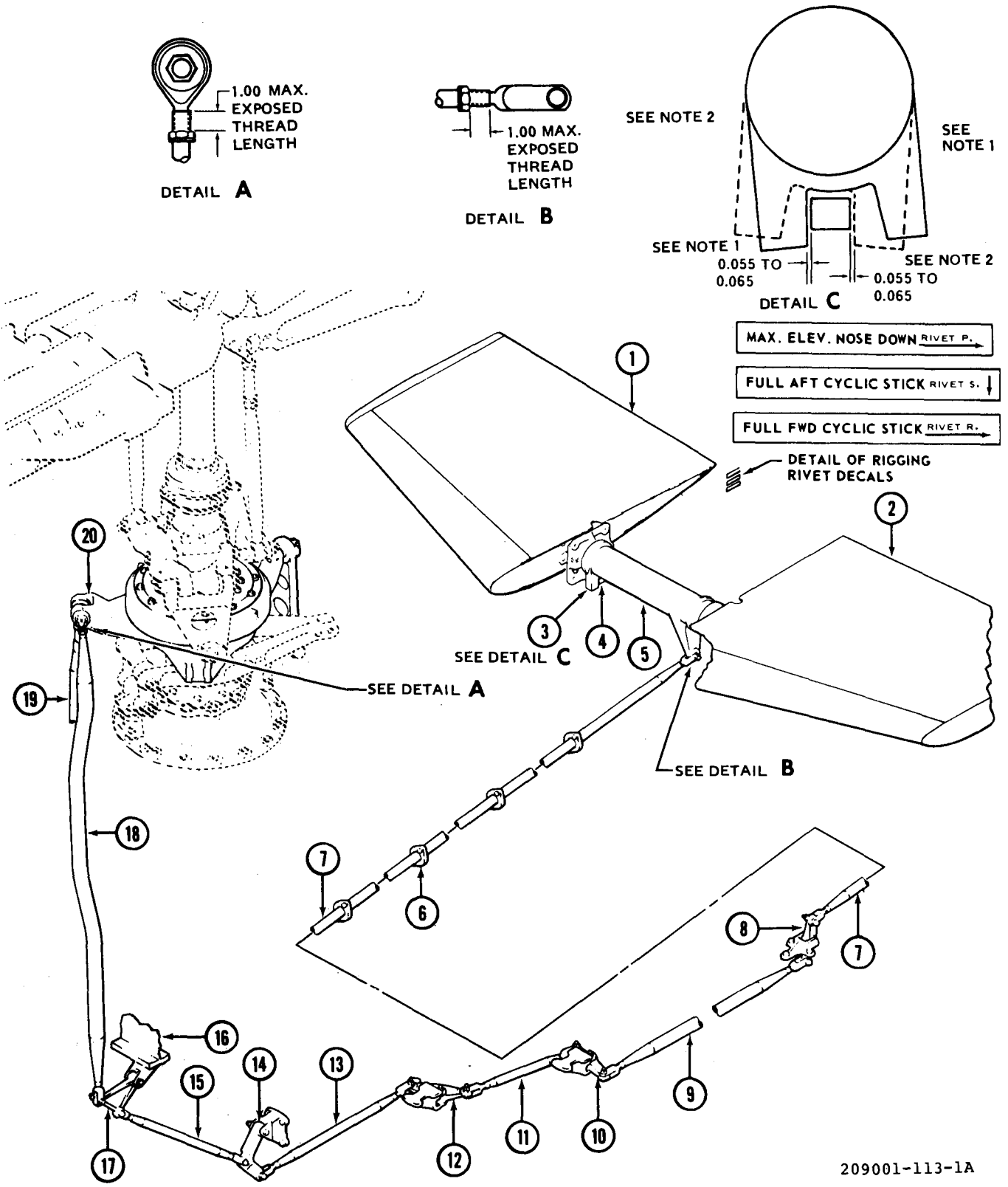

209001-113-1A

ALL DIMENSIONS ARE IN INCHES UNLESS OTHERWISE NOTED.

Figure 11-28. Elevator Control System (Sheet 1 of 2)

**NOTES:**

1. With elevator positioned (trailing edge up) so that there is 0.055 to 0.065 clearance between forward side of stop on horn and stop on support.
2. With elevator positioned (trailing edge down) so that there is 0.055 to 0.065 clearance between aft side of stop on horn and stop on support.

- |  |  |
|--|--|
| <ol style="list-style-type: none"> <li>1. Right elevator</li> <li>2. Left elevator</li> <li>3. Stops (on horn)</li> <li>4. Stop (on support)</li> <li>5. Elevator horn assembly</li> <li>6. Guide (4 reqd)</li> <li>7. Tube assembly</li> <li>8. Walking beam and support</li> <li>9. Tube assembly</li> <li>10. Walking beam and support</li> </ol> | <ol style="list-style-type: none"> <li>11. Tube assembly</li> <li>12. Bellcrank and support</li> <li>13. Tube assembly</li> <li>14. Bellcrank and support</li> <li>15. Tube assembly</li> <li>16. Lift beam</li> <li>17. Bellcrank</li> <li>18. Tube assembly</li> <li>19. Fore-and-aft cyclic hydraulic cylinder tube</li> <li>20. Swashplate inner ring</li> </ol> |
|--|--|

209001-113-2A

Figure 11-28. Elevator Control System (Sheet 2 of 2)

(1) Using hydraulic test stand, (S2) apply hydraulic power to helicopter.

(2) Position pilot cyclic stick full forward against stop. Check that trailing edge of elevator points to rivet "R" on tailboom within **0.40** inch and that there is a **0.055 TO 0.065** inch clearance between stops (3 and 4) as described in step d.(2). Adjust tube assembly (7) if necessary as described in step c.

(3) Move pilot cyclic stick aft. Check for a clearance of **0.055 TO 0.065** inch between stops (3 and 4) when bellcrank (12) passes thru dead center; also, that elevator trailing edge points to rivet "P" within **0.4** inch bellcrank (12) is at dead center as described in step c(2).

(4) Position pilot cyclic stick full aft against stop. Check trailing edge of elevator to ensure that it stops at rivet "S" within **0.4** inch.

f. Move pilot cyclic stick through full range fore-and-aft and ensure that there is no binding or interference in the elevator control system.

g. Disconnect hydraulic test stand.

h. Check complete elevator control system for security and safetying of components. Install access panel (9, figure 2-3) and tailboom access door (21, figure 2-2).

i. Perform maintenance test flight Refer to TM 55-1520-236 MTF.

**11-139. ELEVATOR INSTALLATION.**

**11-140. DESCRIPTION - ELEVATOR INSTALLATION.**

The elevator installation consists of two elevator assemblies and a horn assembly (12, figure 11-29). Each elevator assembly is a horizontal airfoil section built up on a spar tube, which is inserted into a projecting end of the horn assembly and secured by a single bolt. The horn assembly is mounted horizontally through the sides of the tail boom, and is secured to the structure by supports, which serve as bearings for rotational movement. A control arm on the horn provides attachment for elevator control system linkage from the fore-and-aft cyclic control system at the swashplate.

**Premaintenance Requirements for Elevator**

Conditions	Requirements
Model	AH-1S
Part No. or Serial No.	All
Special Tools	None

Conditions	Requirements
Test Equipment	Dial Indicator
Support Equipment	None
Minimum Personnel Required	Two
Consumable Materials	(C31), (C41), (C37), (C88), (C91), (C110)
Special Environmental Conditions	None

**11-141. REMOVAL - ELEVATORS AND HORN ASSEMBLY.**

**NOTE**

**Perform inspection of installed elevators and elevator control system prior to removal (paragraph 11-1 42).**

a. Remove retaining bolt (2, figure 11 -29) and washer (3). Move elevator (1) outboard until spar tube (4) is clear of horn assembly (12).

b. Remove opposite elevator in the same manner.

c. Remove horn assembly (12) as follows:

(1) Remove cotter pin (31), nut (32), washers (33 and 35) and bolt (36). Disconnect tube assembly (34) from horn assembly (12).

**NOTE**

**If horn assembly is to be reinstalled on the same helicopter, index shims (23 and 27) for reinstallation in the same location. Support assemblies (9 and 22) are different part numbers and must be reinstalled in the same location.**

**NOTE**

**Support assemblies (9 and 22) have bearing material bonded to the surfaces that contact the horn assembly. Handle support assemblies carefully to avoid damage.**

(2) Remove nuts (15 and 25), washers (16 and 26), bolts (7 and 20), and washers (8 and 21).

(3) Remove bolts (11) and washers (10). Remove upper half of support assembly (9), shim (6) and shims (17).

(4) Remove upper half of support assembly in the same manner outlined in the preceding step.

(5) Remove bolts (13) and washers (14). Remove lower half of support assembly (9) and shim (6).

(6) Remove lower half of support assembly in the same manner outlined in the preceding step.

(7) Move horn assembly (12) to the right through bracket (5) as far as possible, rotating the control arm as necessary to allow passage of end lug through bracket. Lower left side of horn assembly and move horn assembly inboard and toward access door while removing opposite end of horn and lug through bracket. Remove horn assembly.

**11-142. INSPECTION - ELEVATORS AND ELEVATOR CONTROL SYSTEM.**

a. Inspect installed elevators and elevator control system as follows:

(1) Inspect elevators and elevator control system for secure installation, damage and freedom of operation through full throw.

(2) If damage is detected during accomplishment of step (1), make detailed inspection as outlined in step b.

(3) Inspect elevator support brackets (5, figure 11-29) for loose rivets. Apply enough pressure to elevator at outboard end to provide normal deflection. Inspect rivets visually and by hand contact for signs of movement. No loose or cocked rivets are acceptable. Request assistance of next higher maintenance level if any loose or cocked rivets are found.

b. Inspect elevators and elevator control system components after removal as follows:

(1) Inspect both elevators (1, figure 11-29) for scratches, dents, nicks, cracks, tears and holes. Refer to paragraph 2-330 for damage limits.

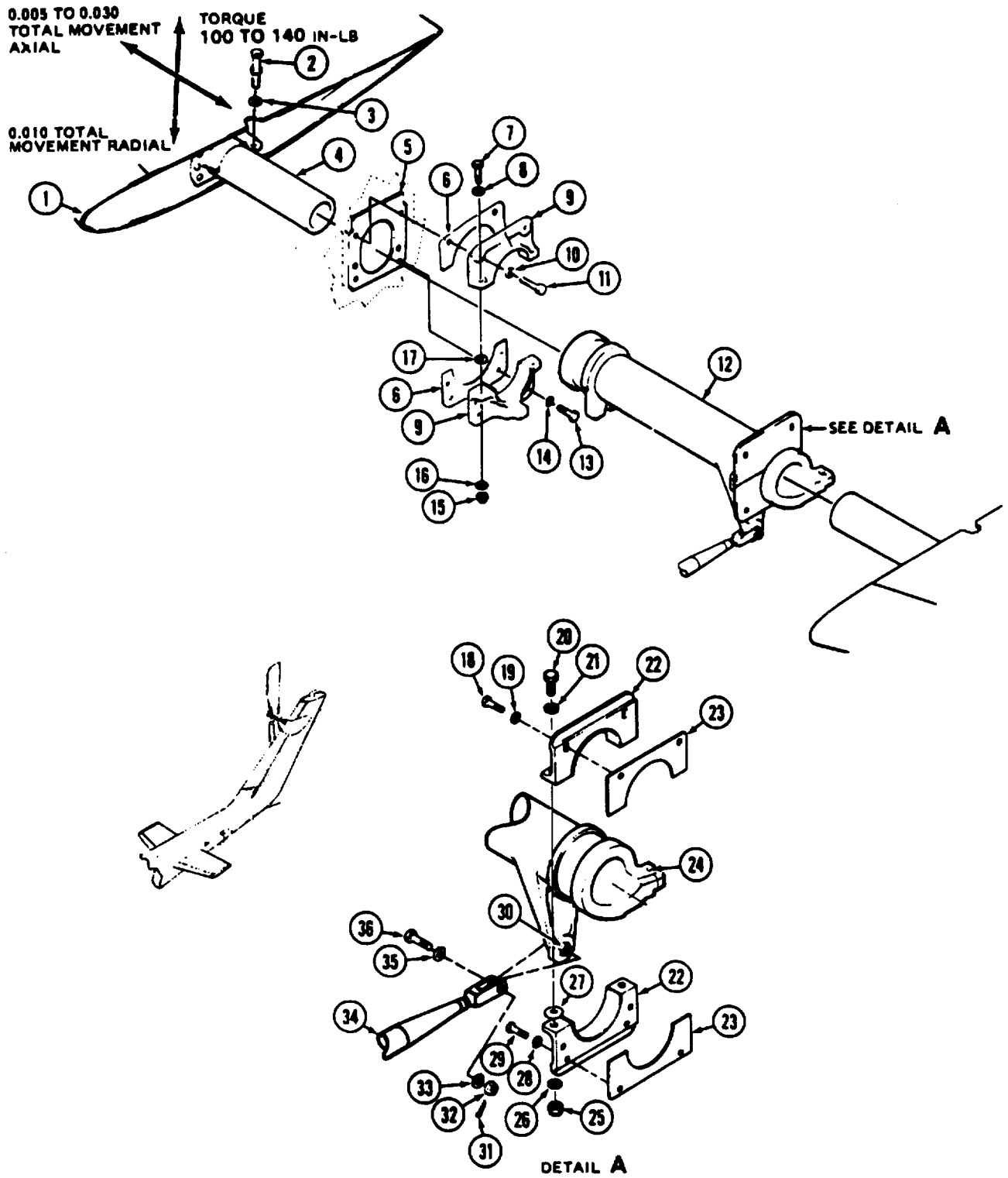

ALL DIMENSIONS ARE IN INCHES UNLESS OTHERWISE NOTED.

Figure 11-29. Elevator Installation (Sheet 1 of 2)

- |                          |                          |                          |
|--------------------------|--------------------------|--------------------------|
| 1. Elevator              | 13. Bolt                 | 25. Nut                  |
| 2. Retaining bolt        | 14. Thin aluminum washer | 26. Thin aluminum washer |
| 3. Aluminum washer       | 15. Nut                  | 27. Shim (2)             |
| 4. Spar tube             | 16. Thin aluminum washer | 28. Thin aluminum washer |
| 5. Support bracket       | 17. Shim (2)             | 29. Bolt                 |
| 6. Shim (2)              | 18. Bolt                 | 30. Bearing              |
| 7. Bolt                  | 19. Thin aluminum washer | 31. Cotter pin           |
| 8. Thin aluminum washer  | 20. Bolt                 | 32. Nut                  |
| 9. Support assembly      | 21. Thin aluminum washer | 33. Steel washer         |
| 10. Thin aluminum washer | 22. Support assembly     | 34. Control tube         |
| 11. Bolt                 | 23. Shim (2)             | 35. Steel washer         |
| 12. Horn assembly        | 24. Nutplate             | 36. Bolt                 |

Figure 11-29. Elevator Installation (Sheet 2 of 2)

(2) Inspect support assemblies (9 and 22, figure 11-29) for mechanical and corrosion damage. See figure 11-33 for damage limits. Inspect support assemblies for damaged and/or loose bearing material. Damaged, loose or excessively worn bearing material is not acceptable.

(3) Clean elevator horn with solvent (C112). Inspect horn assembly (12, figure 11-29) for mechanical and corrosion damage. See figure 11-33 for damage limits. Inspect horn assembly bearing in accordance with instructions in paragraph 11-164. Inspect horn assembly (12, figure 11-29) for cracks by fluorescent penetrant method (TM 43-0103). No sacks are acceptable.

(4) Inspect elevator control system tubes and links shown on figure 11-28 for mechanical and corrosion damage. See figure 11-30 for damage limits.

(5) Inspect elevator control system walking beams, supports, and bellcranks shown on figure 11-28 for mechanical and corrosion damage. See figure 11-33 for damage limits.

(6) Inspect all bearings in the elevator control system shown on figure 11-28 in accordance with instructions in paragraph 11-164.

#### 11-143. REPAIR OR REPLACEMENT — ELEVATORS, HORN ASSEMBLY AND SUPPORT ASSEMBLIES.

a. Replace components that do not meet inspection requirements of paragraph 11-142.

b. Repair elevators with corrosion or mechanical damage that is within repairable limits. Refer to paragraph 2-331 for repair instructions.

c. Polish out mechanical and corrosion damage on horn assembly (12, figure 11-29) that is within limits shown on figure 11-32. Polish to a smooth, scratch free finish with crocus cloth (C37). Blend edges of repair into surrounding area. Apply chemical film coating (C31) to repair areas. Prime repaired areas with primer (C88 or C91).

d. Replace faulty bearing in horn assembly (12, figure 11-33). Refer to paragraph 11-184 for procedure.

#### 11-144. INSTALLATION — ELEVATORS AND HORN ASSEMBLY.

a. Insert horn assembly (12, figure 11-23) through access opening in tailboom with control arm toward left side of tailboom. Rotate control arm to approximate vertical position and insert lug of horn through support bracket (5) on left side of tailboom. Move horn assembly outboard as far as possible. Raise opposite end of horn assembly and rotate control arm downward as necessary to allow lug at horn assembly to pass through support brackets (5) on right side of tailboom.

b. Position lower shim (23) and support assembly (9) on support bracket (5). Install bolts (13) and thin aluminum washers (14). Install shim (23) and support assembly (22) in the same manner.





**c.** Position upper shim (6) and support assembly (9) on bracket (5). Install bolts (11) and thin aluminum washers (10). Install upper shim (6) and support assembly (22) in the same manner.

**d.** Move horn assembly (12) from side to side and measure movement between support assembly (9) and horn assembly (12). If lateral movement is not **0.005 TO 0.030** inch, add or remove shims (6 and 23) to obtain movement within limits.

**e.** Coat spar tube (4) of elevator (1) with corrosion preventive compound (C41). Insert spar tube (4) of elevator (1) in horn assembly (12). Align holes of elevator fitting with horn assembly lug and install bolt (2) and aluminum washers (3), torque bolt (2) **100 TO 140** inch-pounds. Install opposite elevator in the same manner.

**f.** Check clearance between elevators and tailboom. If there is not adequate clearance on both sides, move shim sets (6 and 23) as required to obtain equal clearance after removing the elevator.

**g.** Remove two bolts (11) and washers (10). install two shims (17), bolts (7), thin aluminum washers (8), thin aluminum washers (16), and nuts (15). Torque nuts (15) **50 TO 70** inch-pounds. Install shims (27) in the same manner but do not torque nuts (25) at this time.

**h.** Measure amount of force required to rotate horn assembly (12), Use a force gage (fish scale) with a **0 TO 50** pound range. Attach gage at bearing (30) and pull perpendicular to control arm. Force required should be **13 TO 16** pounds. Adjust thickness of shims (17) until force required to rotate horn is **13 TO 16** pounds with nuts (15) torqued **50 TO 70** inch-pounds.

**i.** Torque nuts (25) that were installed in step g, **50 TO 70** inch-pounds.

**j.** Measure amount of force required to rotate horn assembly as outlined in step h. The force required should now be **26 TO 32** pounds. Adjust thickness of shims (27) until force required to rotate horn is **26 TO 32** pounds with nuts (25) torqued **50 TO 70** inch-pounds.

**k.** Install two bolts (11) and thin aluminum washers (10). Install two bolts (18) and thin aluminum washers (19).

**l.** Position control tube (34) on horn assembly (12). Install bolt (36), steel washers (35 and 33), nut (32), and cotter pin (31).

**m.** Install elevator in accordance with paragraph 11-144e. Check elevator rigging (paragraph 11-138).

## SECTION II. FLIGHT CONTROL COMPONENTS

### 11-145. FLIGHT CONTROL COMPONENTS.

#### 11-146. DESCRIPTION - FLIGHT CONTROL COMPONENTS.

The flight control components covered in this section are the control tubes, links, bellcranks, levers, walking beams, and supports illustrated in figure 11-31.

#### 11-147. FLIGHT CONTROL TUBES AND LINKS.

#### 11-148. DESCRIPTION - FLIGHT CONTROL TUBES AND LINKS.

The flight control system tube assemblies and links (figure 11-31) are used in all the flight control systems. Fixed length tube assemblies are used as much as possible, but adjustable lengths are required in some locations to rig the controls.

### Premaintenance Requirements for Control Tubes - Cyclic, Collective Anti-torque and Synchronized Elevator System

Conditions	Requirements
Model	AH-1S
Part No. or Serial No.	All
Special Tools	None
Test Equipment	Force Gage (Fish Scale)
Support Equipment	None
Minimum Personnel Required	Two
Consumable Materials	(C31), (C36) (C88), (C102)
Special Environmental Conditions	None

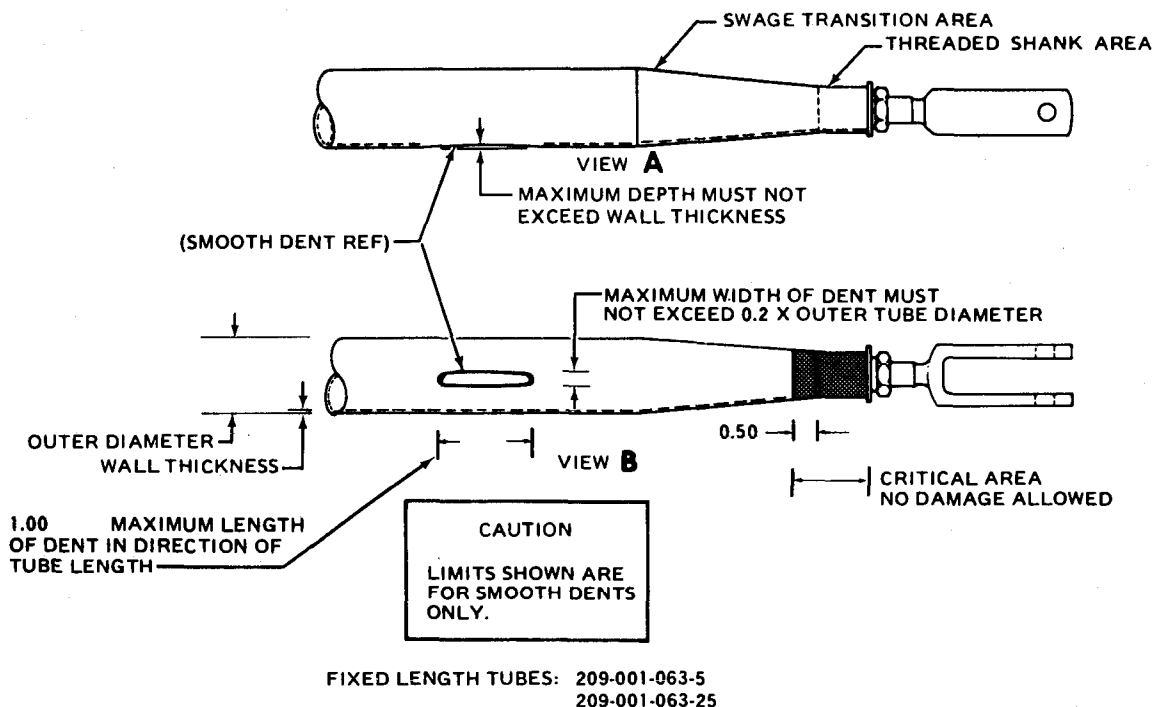

ALL DIMENSIONS ARE IN INCHES UNLESS OTHERWISE NOTED

TYPE OF DAMAGE      MAXIMUM DEPTH AND REPAIR AREAS ALLOWED

CRACKS ALLOWED      NONE

MECHANICAL AND CORROSION DAMAGE ALLOWED OTHER THAN DENTS

PART NUMBER	TUBE DIAMETER	WALL THICKNESS	CIRCUMFERENCIAL WIDTH OF REPAIRED AREA		
			.25 IN	25 PERCENT	50 PERCENT
209-001 -063-5 Before Repair After Repair	.875	.035	.002	.0015	.001
			.0035	.003	.002
209-001-063-25 Before Repair After Repair	.750	.049	.0025	.002	.002
			.005	.004	.003
Remaining P/N to be added later. Before Repair After Repair	Diameter to be added later.	.058	.003	.002	.002
			.006	.004	.004

NOTES:

Rework parts by smoothing out scratches, nicks or corrosion with 400 grit sandpaper (CI 02), and finish to original surface condition. Finish in a longitudinal direction.

209001-175-1

Figure 11-30. Damage Limits - Fixed Length Flight Control Tubes and Links (Typical) (Sheet 1 of 3)

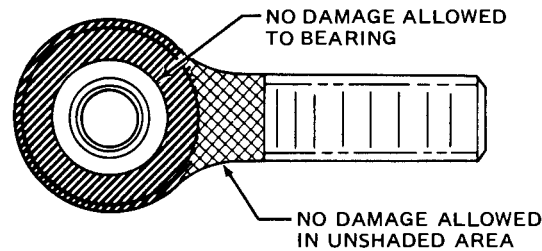
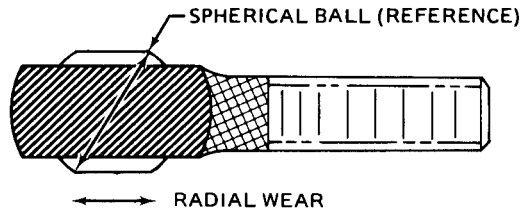

FIXED LENGTH TUBES: 209-001-063-5  
209-001-063-25

**DAMAGE LOCATION SYMBOLS**



TYPE OF DAMAGE	MAXIMUM DEPTHS AND REPAIR AREAS ALLOWED	
	Symbol 1 (Cross-hatched)	Symbol 2 (Diagonal hatched)
CRACKS	None	None
NICKS, SCRATCHES, DENTS AND CORROSION (AFTER CLEAN UP)	None	0.007
MAXIMUM AREA PER FULL DEPTH REPAIR	None	0.10 Sq. In.
NUMBER OF REPAIRS	None	Two
EDGE CHAMFER	None	0.02 x 0.02
THREAD DAMAGE:	N/A	
DEPTH:	One-third of thread	
LENGTH:	One-fourth inch	
NUMBER:	Two	
BEARING/RADIAL WEAR	Maximum acceptable radial play is 0.006	
BEARING/AXIAL WEAR	Maximum acceptable axial play is 0.015	

ALL DIMENSIONS ARE IN INCHES UNLESS OTHERWISE NOTED

209001-175-2

Figure 11-30. Damage Limits - Fixed Length Flight Control Tubes and Links (Typical) (Sheet 2 of 3)

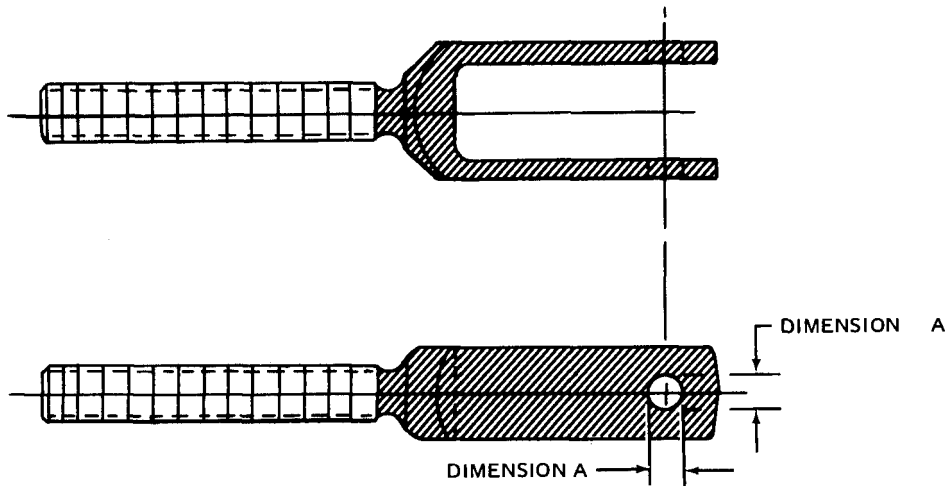

FIXED LENGTH TUBES: 209-001-063-5  
209-001-063-25

**DAMAGE LOCATION SYMBOL**



TYPE OF DAMAGE	MAXIMUM DEPTHS AND REPAIR AREAS ALLOWED
CRACKS ALLOWED	None
NICKS, SCRATCHES, SHARP DENTS	0.005
CORROSION	
AFTER REPAIR	0.005
MAXIMUM AREAR PER FULL DEPTH REPAIR	0.10 Sq. In.
NUMBER OF REPAIRS	One Per Segment
EDGE CHAMFER	0.020 x 0.020
THREAD DAMAGE:	
DEPTH:	One-third of thread
LENGTH:	One-quarter inch
NUMBER:	Two
RADIAL WEAR/ELONGATION OF CLEWS HOLE (DIMENSION A)	0.005

ALL DIMENSIONS ARE IN INCHES UNLESS OTHERWISE NOTED

209001-175-3

Figure 11-30. Damage Limits - Fixed Length Flight Control Tubes and Links (Typical) (Sheet 3 of 3)

**NOTES:**

1. Coat clevis threads with corrosion prevention compound. MIL-C-16173, grade II on assembly.
2. Typical bolt installation for control tubes and links. One washer under bolt head and one under nut. Safety with cotter pin.
3. Typical bolt installation for bellcranks. One washer under bolt head and one under nut. Safety with cotter pin.

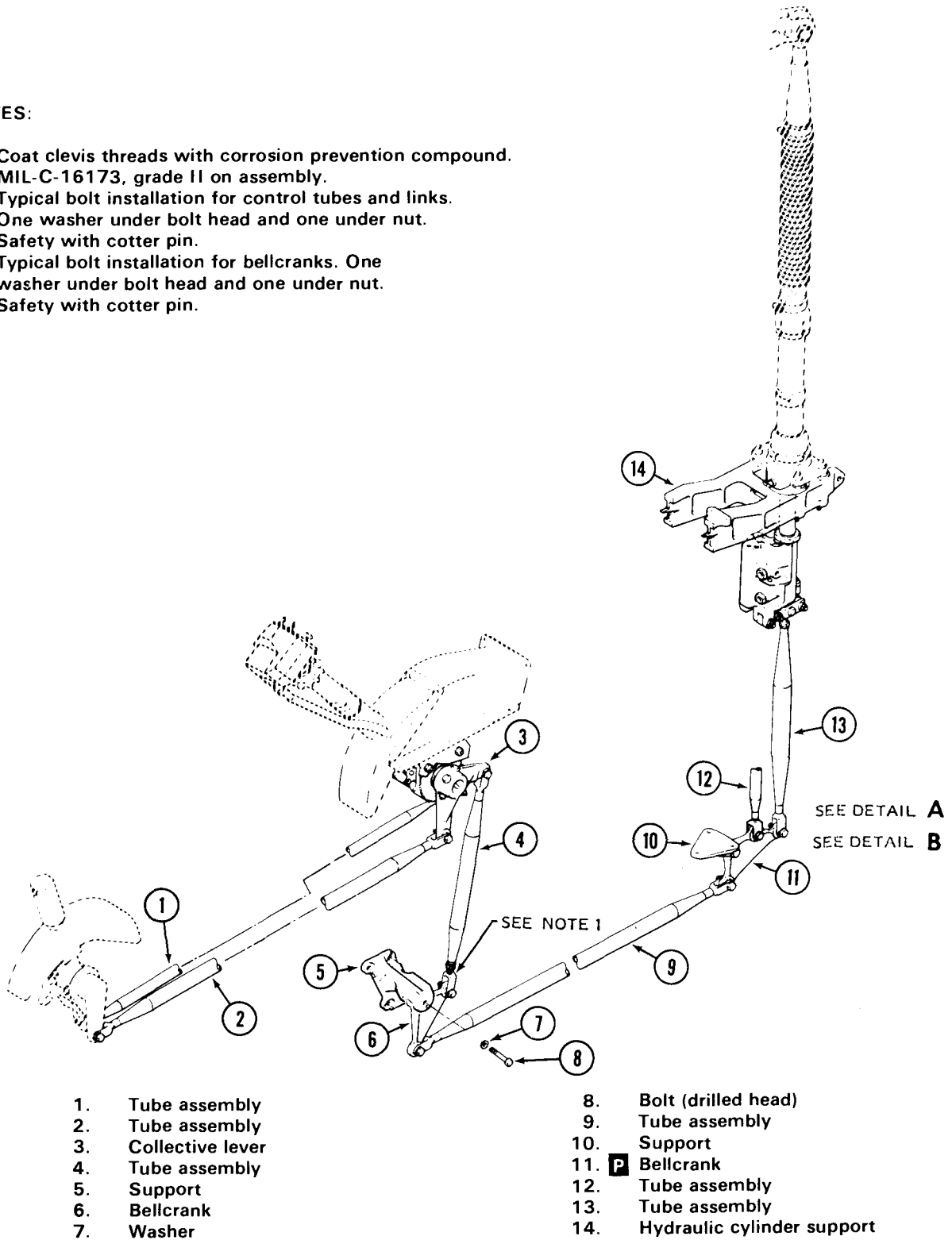

- |                     |                                |
|---------------------|--------------------------------|
| 1. Tube assembly    | 8. Bolt (drilled head)         |
| 2. Tube assembly    | 9. Tube assembly               |
| 3. Collective lever | 10. Support                    |
| 4. Tube assembly    | 11. <b>P</b> Bellcrank         |
| 5. Support          | 12. Tube assembly              |
| 6. Bellcrank        | 13. Tube assembly              |
| 7. Washer           | 14. Hydraulic cylinder support |

209001-171-1

Figure 11-31. Control System Linkage Installation (Sheet 1 of 7)

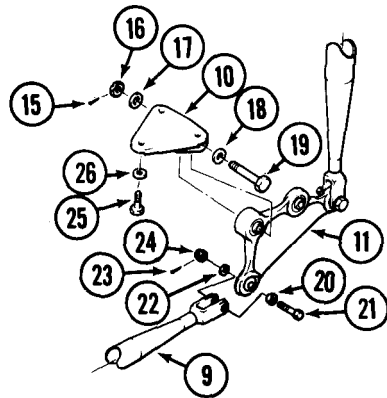

**P E** DETAIL A

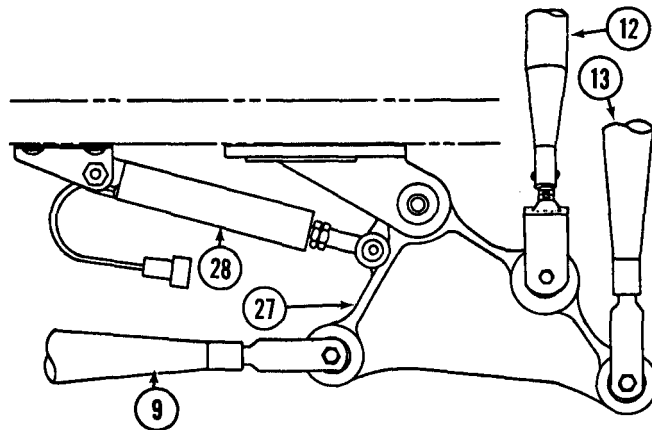

**M M** DETAIL B

- 15. Cotter pin
- 16. Nut
- 17. Washer
- 18. Washer
- 19. Bolt
- 20. Washer
- 21. Bolt
- 22. Washer
- 23. Cotter pin
- 24. Nut
- 25. Bolt
- 26. Washer
- 27. **M** Bellcrank
- 28. **M** Transducer

209001-171-2

Figure 11-31. Control System Linkage Installation (Sheet 2 of 7)

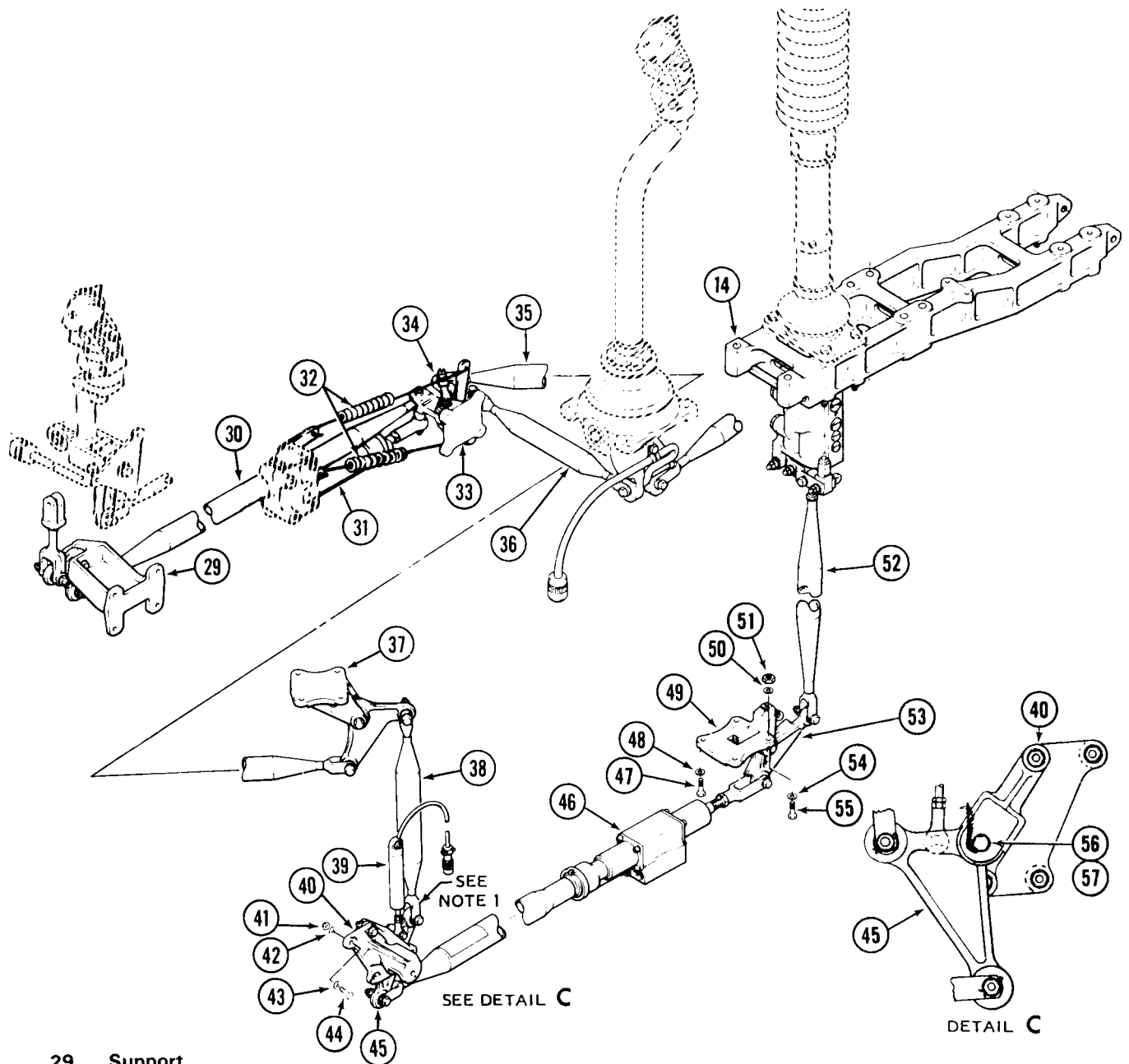

- |   |                         |                         |
|---|-------------------------|-------------------------|
| 29. Support                               | 40. Support             | 49. Support             |
| 30. Tube assembly                         | 41. Nut                 | 50. Washer              |
| 31. Force gradient                        | 42. Washer              | 51. Nut                 |
| 32. Gunner lateral cyclic control springs | 43. Washer              | 52. Tube assembly       |
| 33. Bellcrank                             | 44. Bolt                | 53. Bellcrank           |
| 34. Support                               | 45. Bellcrank           | 54. Washer              |
| 35. Tube assembly                         | 46. SCAS servo actuator | 55. Bolt                |
| 36. Tube assembly                         | 47. Bolt                | 56. Washer              |
| 37. Support                               | 48. Washer              | 57. Bolt (drilled head) |
| 38. Tube assembly                         |                         |                         |
| 39. Lateral motion transducer             |                         |                         |

209001-171-3

Figure 11-31. Control System Linkage Installation (Sheet 3 of 7)

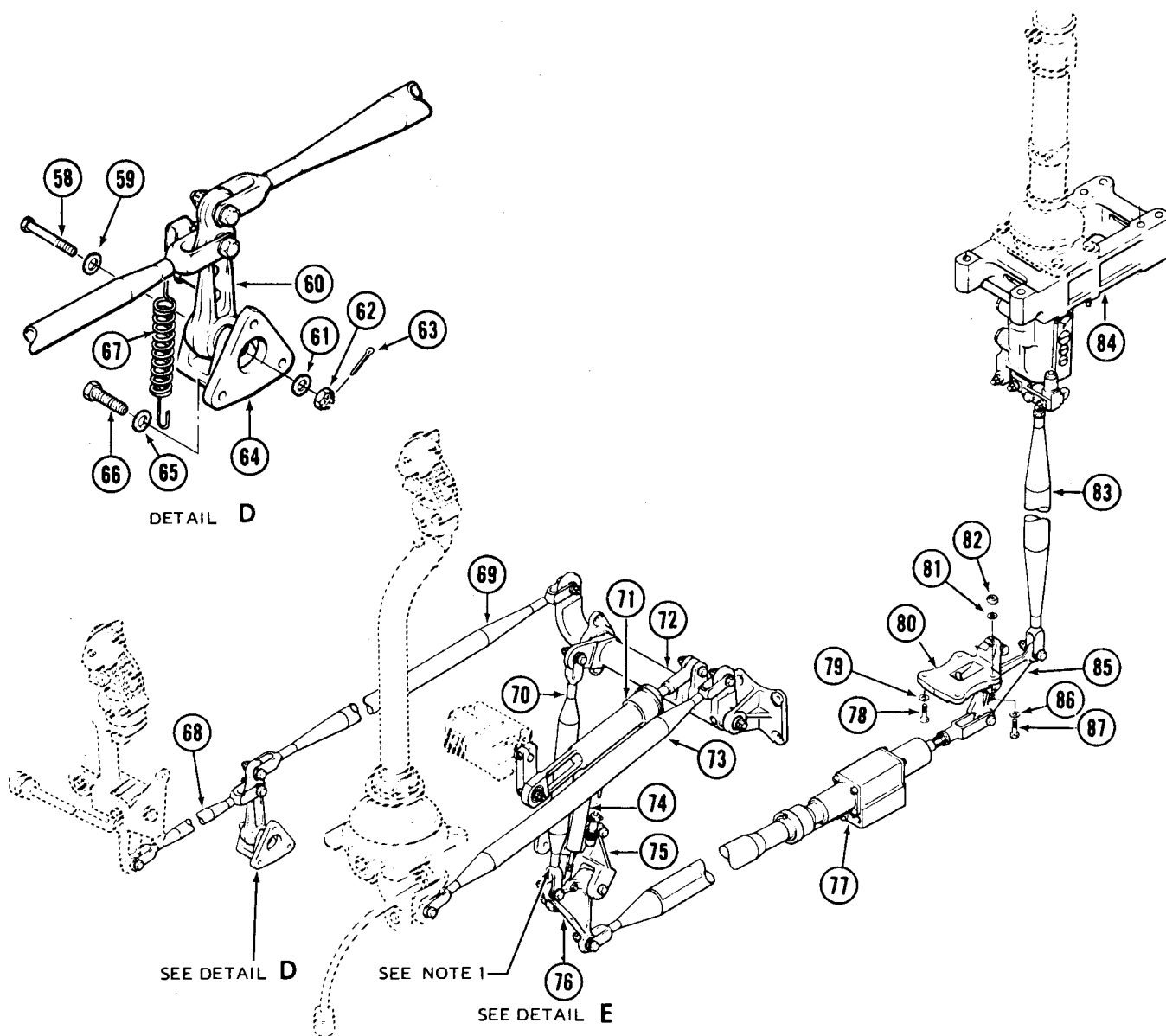

- |  |                                    |                                |
|--|------------------------------------|--------------------------------|
| 58. Bolt                                       | 69. Tube assembly                  | 79. Washer                     |
| 59. Washer                                     | 70. Tube assembly                  | 80. Support                    |
| 60. Idler crank                                | 71. Force gradient                 | 81. Washer                     |
| 61. Washer                                     | 72. Jackshaft                      | 82. Nut                        |
| 62. Nut  | 73. Tube assembly                  | 83. Tube assembly              |
| 63. Cotter pin                                 | 74. Fore-and-aft motion transducer | 84. Hydraulic cylinder support |
| 64. Idler support                              | 75. Support                        | 85. Bellcrank                  |
| 65. Washer                                     | 76. Bellcrank                      | 86. Washer                     |
| 66. Bolt                                       | 77. SCAS servo actuator            | 87. Bolt                       |
| 67. Gunner longitudinal cyclic control springs | 78. Bolt                           |                                |
| 68. Tube assembly                              |                                    |                                |

209001-171-4

Figure 11-31. Control System Linkage Installation (Sheet 4 of 7)



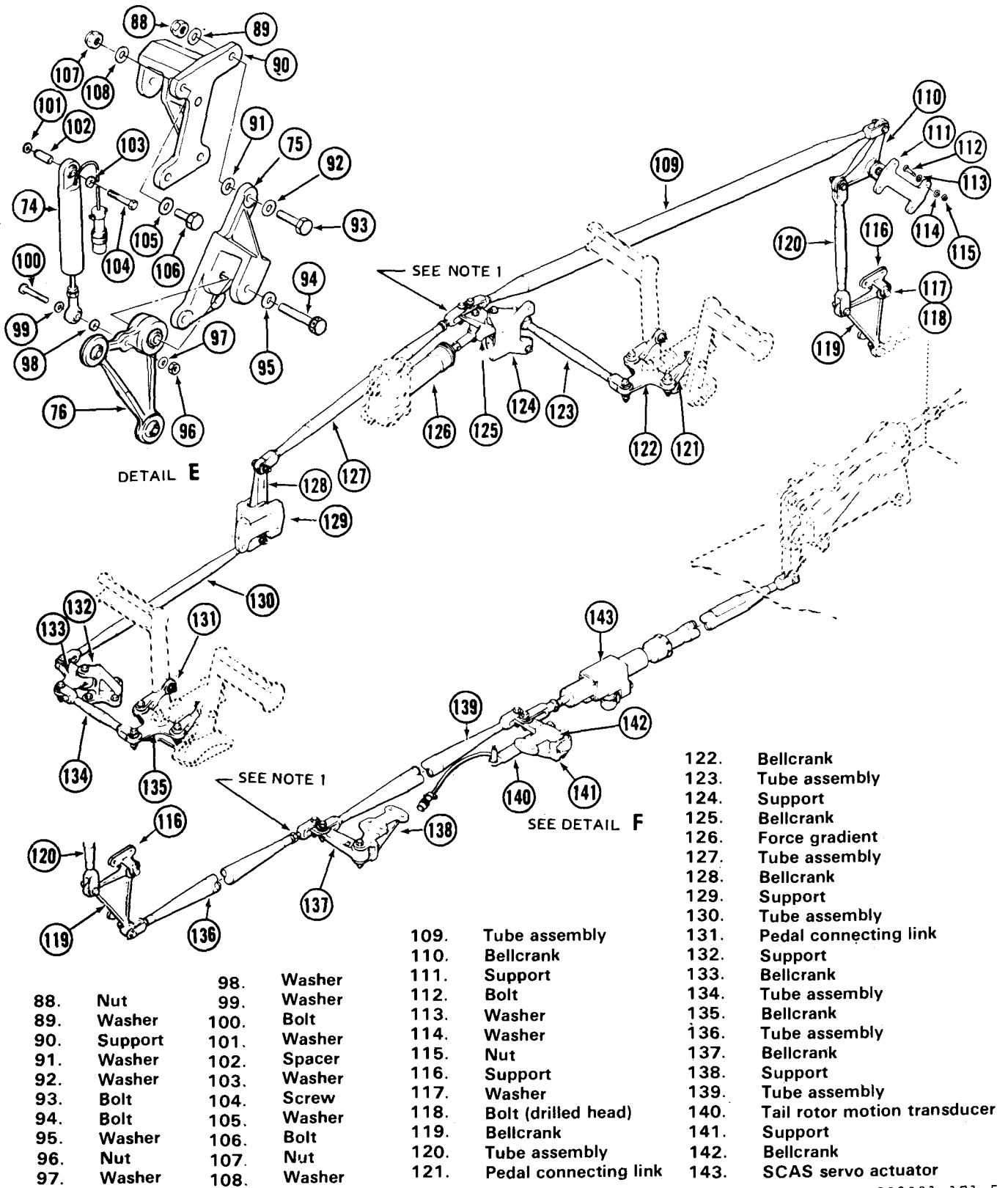

- 88. Nut
- 89. Washer
- 90. Support
- 91. Washer
- 92. Washer
- 93. Bolt
- 94. Bolt
- 95. Washer
- 96. Nut
- 97. Washer
- 98. Washer
- 99. Washer
- 100. Bolt
- 101. Washer
- 102. Spacer
- 103. Washer
- 104. Screw
- 105. Washer
- 106. Bolt
- 107. Nut
- 108. Washer

- 109. Tube assembly
- 110. Bellcrank
- 111. Support
- 112. Bolt
- 113. Washer
- 114. Washer
- 115. Nut
- 116. Support
- 117. Washer
- 118. Bolt (drilled head)
- 119. Bellcrank
- 120. Tube assembly
- 121. Pedal connecting link
- 122. Bellcrank
- 123. Tube assembly
- 124. Support
- 125. Bellcrank
- 126. Force gradient
- 127. Tube assembly
- 128. Bellcrank
- 129. Support
- 130. Tube assembly
- 131. Pedal connecting link
- 132. Support
- 133. Bellcrank
- 134. Tube assembly
- 135. Bellcrank
- 136. Tube assembly
- 137. Bellcrank
- 138. Support
- 139. Tube assembly
- 140. Tail rotor motion transducer
- 141. Support
- 142. Bellcrank
- 143. SCAS servo actuator

209001-171-5

Figure 11-31. Control System Linkage Installation (Sheet 5 of 7)

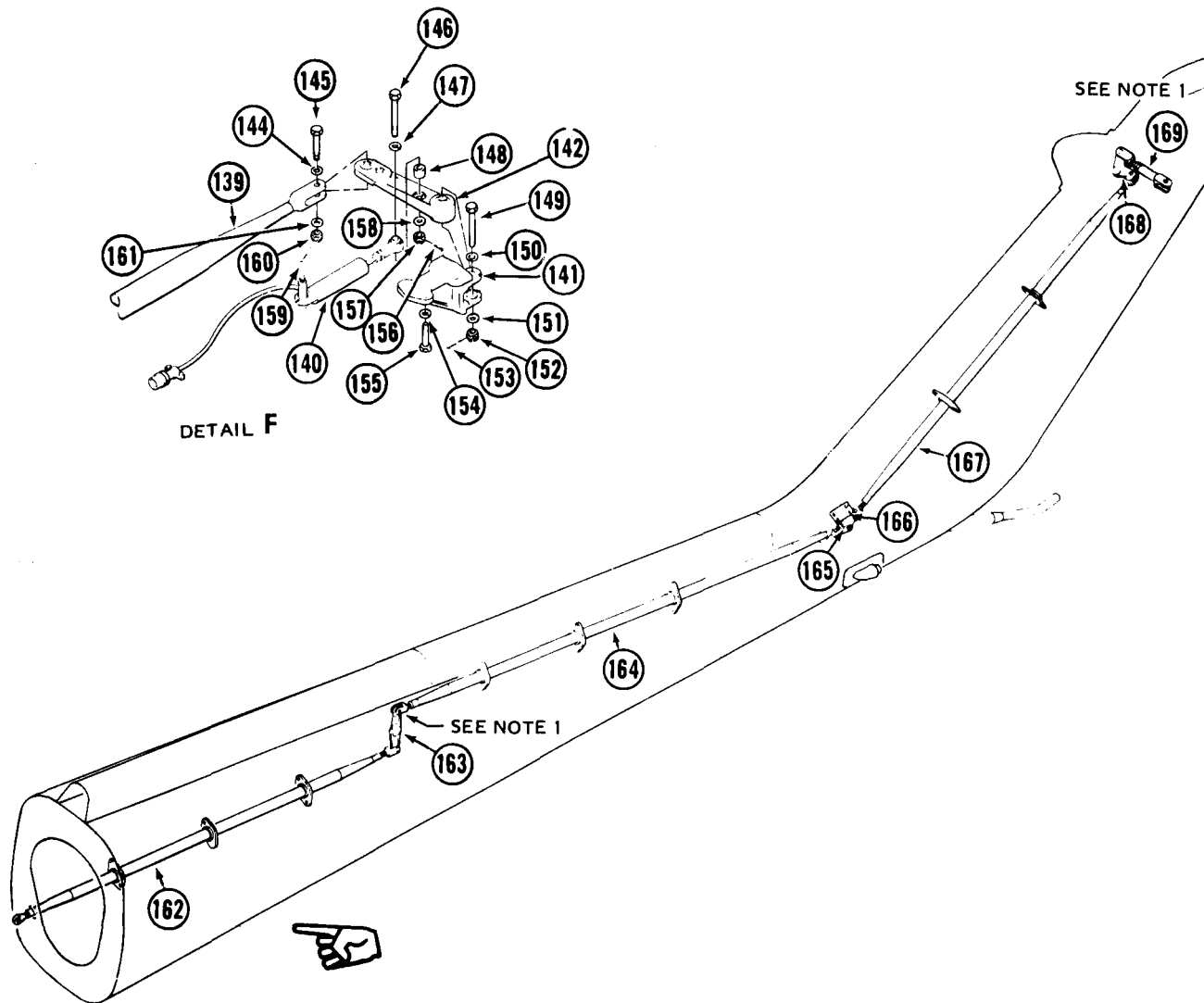

- 144. Washer
- 145. Bolt
- 146. Bolt
- 147. Washer
- 148. Spacer
- 149. Bolt
- 150. Washer
- 151. Washer
- 152. Nut
- 153. Cotter pin
- 154. Washer
- 155. Bolt
- 156. Cotter pin

- 157. Nut
- 158. Washer
- 159. Cotter pin
- 160. Nut
- 161. Washer
- 162. Tube assembly
- 163. Beam assembly
- 164. Tube assembly
- 165. Bellcrank
- 166. Support
- 167. Tube assembly
- 168. Bellcrank
- 169. Control link

209001-171-6

Figure 11-31. Control System Linkage Installation (Sheet 6 of 7)

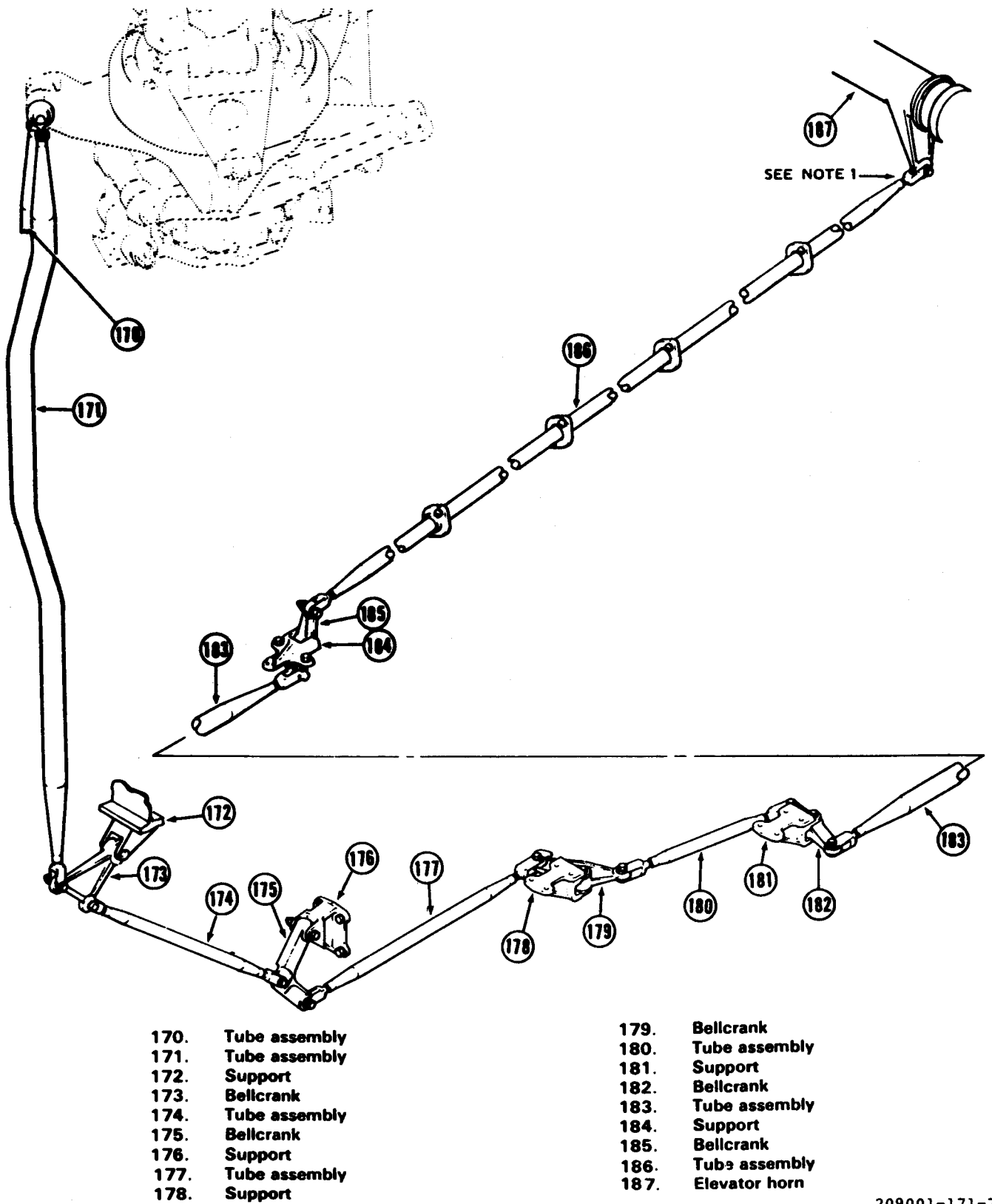

209001-171-7

Figure 11-31. Control System Linkage Installation (Sheet 7 of 7)

**11-149. REMOVAL - FLIGHT CONTROL TUBES AND LINKS.**

**NOTE**

Parts of control system can be removed separately as need occurs, or completely, in practical sequence. Take precautions against accidental movement of linkage while disconnected.

**NOTE**

Elevator Control tube (186, figure 11-31) may be removed by first removing the four guides (6, figure 11-28) and sliding tube out or in through access panel under the elevator.

- a. Remove access covers as required.
- b. Remove components as required to gain access to flight control tubes or links. Refer to chapter that pertains to obstructing component for removal procedures.
- c. Remove control tubes and/or links as required.

**11-150. INSPECTION - FLIGHT CONTROL TUBES AND LINKS.**

a. Inspect all fixed length control tubes for dents, scratches, corrosion, friction wear, nicks and abrasions. See figure 11-30.

**NOTE**

**A smooth dent is one that does not contain a scratch and/or a nick.**

(1) The maximum allowable depth of a smooth dent is equal to the wall thickness of the tube body. See figure 11-30.

(2) The maximum allowable width of a smooth dent is equal to 20 percent of the outer tube diameter. See figure 11-30.

b. Scratches, nicks, and/or abrasions maybe grouped together and reworked, provided repair areas do not exceed the limits shown in figure 11-30.

c. Inspect all rod end bearings, anti-torque pedal connecting link bearing, and bearings installed in bellcranks (paragraph 11-164). Refer to TM 55-1500-204-25/1 for

additional bearing inspection information.

d. If any evidence is noted in steps a. through h. that a part is cracked, make fluorescent penetrant inspection in accordance with TM 43-0103. No cracks are acceptable.

**NOTE**

When chafing strips become worn through, you may rotate control tube 180° (on straight tubes). Do not turn end for end or change tube length. If this is not possible, you should replace the tube when the inspection limitations for the tube have been exceeded.

e. Inspection criteria for control tubes not listed in figure 11-30:

(1) Inspect tube portion for scratches and score marks as follows:

(a) Maximum allowable dents when scratches and scores are less than 45 degrees to lengthwise center line of tube is 0.010 inch.

(b) Maximum allowable depth when scratches and score marks are more than 45 degrees to center line of tube is 0.005 inch.

(2) Inspect tube portion for corrosion damage. Maximum allowable depth is 0.005 inch before repair and 0.010 inch after repair.

(3) Maximum allowable width of repair area at any given section of tube is one-third of tube circumference.

(4) No thread damage is acceptable. No repair to any surface is acceptable if the repair will affect threads.

(5) Inspect clevises and rod ends for nicks, scratches and corrosion. Maximum allowable depth of mechanical damage is 0.010 inch. Maximum allowable corrosion damage is 0.005 inch before repair and 0.010 after repair.

(6) Inspect bolt holes for wear. Maximum allowable wear is 0.005 inch.

(7) Inspect area on surfaces surrounding bolt holes for mechanical and corrosion damage. Maximum allowable repair of mechanical and/or corrosion damage within distance of one diameter from edge of hole is 25 percent of area.

(8) Inspect bearings for wear and/or damage in excess of limits. Refer to paragraph 11-162.

**11-151. REPAIR OR REPLACEMENT - FLIGHT CONTROL TUBES AND LINKS.**

**a.** Replace all parts that fail to meet inspection requirements of paragraph 11-150. Polish out all minor corrosion and mechanical damage that does not exceed damage limits. Do not remove more material than necessary to blend repair smoothly into surrounding surface. Use fine to medium grades of sandpaper (C102) or abrasive cloth (C36). Do not use grinding wheels. Polish out mechanical damage only deep enough to remove traces of damage. Polish out corrosion damage to twice the depth of the deepest pit.

**b.** Touch up repair area on aluminum parts with chemical film (C31) and primer (C88 or C91). Touch up repair area on steel parts with primer (C88 or C91).

**c.** Refer to paragraph 11-165 if bearings are worn beyond acceptable limits.

**d.** Replace worn bushings in pedal connecting links (119 and 129, figure 11-31). Refer to paragraph 11-97.

**11-152. INSTALLATION - FLIGHT CONTROL TUBES AND LINKS.**

**a.** Install bellcranks, levers, walking beams and supports if these parts were removed. Refer to paragraph 11-159 and 11-160.

**b.** Install fixed length tubes and links. See figure 11-34. Ensure that cotter pins are installed where applicable. See figure 11-31, detail A for typical installations.

**c.** Adjust (rig) and install adjustable length tubes and links. Refer to paragraphs 11-7, 11-29, 11-55, and 11-38 as applicable.

**d.** Install components that were removed to gain access to flight control tubes and links.

**e.** Ensure that all safety devices (cotter pins and lockwire) are installed in the flight control system being repaired.



f. Move controls through full throw and ensure that there is no binding or interference.

g. Install access panels.

**11-153. FUNCTIONAL CHECK - FLIGHT CONTROL TUBES AND LINKS.**

Perform maintenance test flight.

**11-154. BELLCRANKS, LEVERS, WALKING BEAMS, AND SUPPORTS.**

**NOTE**

Refer to paragraph 11-167 for maintenance instructions for cyclic and collective power cylinder (hydraulic cylinder assembly) supports.

**11-155. DESCRIPTION – BELLCRANKS, LEVERS, WALKING BEAMS AND SUPPORTS (figure 11-31).**

Bellcranks, levers and walking beams are utilized in all control systems to change direction of movement and amount of motion in the control system. Supports provide for attachment of the flight controls to the airframe.

**Premaintenance Requirements for Bellcranks, Levers, Walking Beams, and supports**

Conditions	Requirements
Model	AH-IS
Part No. or Serial No.	All
Special Tools	None
Test Equipment	Force Gage (Fish Scale)
Support Equipment	None
Minimum Personnel Required	Two
Consumable Materials	(C31), (C36), (C88), (C91), (C99), (C138), (C102)
Special Environmental Conditions	None

**11-156. REMOVAL - BELLCRANKS, LEVERS, WALKING BEAMS, AND SUPPORTS.**

**NOTE**

Parts of control system can be removed separately as need occurs or completely, in practical sequence. Take precautions against accidental movement of linkage while disconnected.

- a. Remove access covers as required.
- b. Remove flight control tubes and links as required (paragraph 11-149).
- c. Disconnect cyclic force gradient if required (paragraph 11-65).
- d. Disconnect tail rotor force gradient if required (paragraph 11-92).
- e. Disconnect SCAS motion transducers if required (paragraph 11-122).
- f. Disconnect springs (32, figure 11-31) from lateral bellcrank (32) and spring (67) from longitudinal idler crank (59) if required.
- g. Disconnect droop compensator tube assembly (12). Refer to paragraph 4-85.
- h. Remove SCAS servo actuators (46, 77, and 143). Refer to paragraph 7-73.
- i. Remove lockwire, cotter pins, nuts, washers, and bolts that attach bellcranks, levers, and walking beams to supports. Remove bellcranks, levers, and walking beams.
- j. Remove collective support (5), lateral support (40), fore-and-aft support (75), and tail rotor support



Lateral and collective supports (5 and 40) and tail rotor and fore-and-aft supports (75, 110, and 116) use some common hardware for airframe attachment. Immobilize both systems if either support is removed.

(111 or 116) by removing bolts, (44, 93, 118, and 112), washers (42, 43, 89, 91, 92, 113, 114, and 117), and nuts (41, 88, and 115).

**k.** Remove idler crank support (64) by removing three bolts (66) and washers (65).

**l.** Separate idler crank (60) from support by removing cotter pin (63), nut (62), washers (59 and 61), and bolt (58).

**NOTE**

Lateral and fore-and-aft support (49 and 80) have nuts on aft bolts. Tail rotor supports (111 and 124) have a nut on lower bolt (58).

**m.** Remove remaining supports by removing bolts and washers.

**11-157, INSPECTION - BELLCRANKS, LEVERS, WALKING BEAMS, AND SUPPORTS.**

**a.** Inspect bearings for wear and/or damage. Refer to paragraph 11-164 for limits.

**b.** Inspect all parts for mechanical and corrosion damage. See figures 11-33 through 11-35 for limits.

**c.** Inspect bolt holes (bushings) for wear. Maximum acceptable elongation is 0.005 inch.

**d.** Inspect area on surfaces surrounding bolt holes for mechanical and corrosion damage. Maximum acceptable repair or mechanical and/or corrosion damage within distance of one diameter from edge of hole is 25 percent of area.

**e.** Inspect all threaded areas for damaged threads.

**11-158, REPAIR OR REPLACEMENT - BELLCRANKS, LEVERS, WALKING BEAMS, AND SUPPORTS,**

**a.** Replace damaged threaded inserts (paragraph 11-13).

**b.** Replace bushings that are worn beyond acceptable limits.

**c.** Polish out minor corrosion and mechanical damage that does not exceed inspection limits. Do not remove more material than necessary to blend repair smoothly into surrounding surface. Use fine to medium grade of sandpaper (C102) or abrasive cloth (C36). Do not use grinding wheels. Polish out mechanical damage only deep enough to remove traces of damage. Polish out corrosion damage to twice the depth of the deepest pit.

**d.** Touch up repair area on aluminum parts with chemical film (C31) and primer (C88 or C91), Touch up repair area on steel parts with primer (C88 or C91).

**e.** Refer to paragraph 11-165 for instructions to replace bearings.

**11-159. INSTALLATION - BELLCRANKS, LEVERS, WALKING BEAMS, AND SUPPORTS.**

**a.** Install bellcranks, levers, walking beams and supports that are removed. See figure 11-31, detail A for typical installations.

**b.** Attach lateral and collective supports (5 and 40) to airframe with bolts (44), washers (42 and 43), and nuts (41). Place one washer under bolt head and one washer under nut.



**Washers (91) must be installed between tail rotor control support (90) and airframe. Failure to do so will cause binding in tail rotor controls.**

**c.** Attach fore-and-aft and tail rotor supports (75 and 90) to airframe with bolts (93), washers (89, 91, and 92), and nuts (88). Place washers (91) between tail rotor support and airframe. Place one washer under bolt head and one under nut.

**NOTE**

Lateral and collective supports (5 and 40) and tail rotor and fore-and-aft supports (75, 111, and 116) use common hardware for airframe attachment.

**d.** Install idler crank (60) in support (64) with bolt (58), washers (59 and 61), and nut (62). Place one washer under bolt head and one washer under nut.



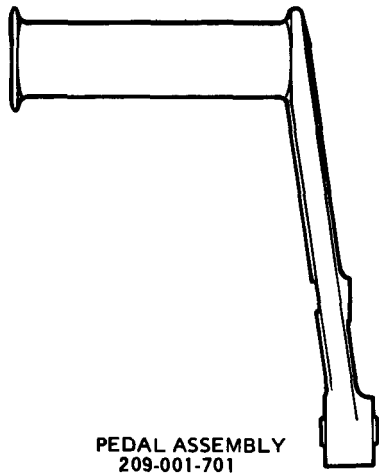

PEDAL ASSEMBLY  
209-001-701

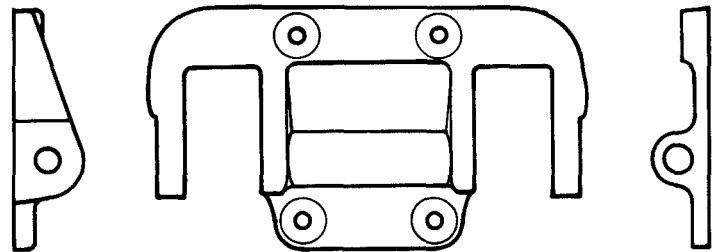

PEDAL SUPPORT  
209-001-702

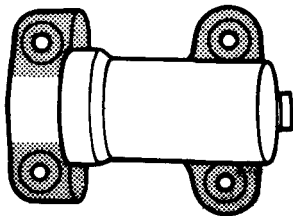

PEDAL ADJUSTER SUPPORT  
209-001-703

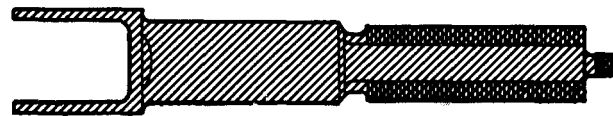

PEDAL ADJUSTER CLEVIS  
209-001-704

**DAMAGE LOCATION SYMBOLS**



**TYPE OF DAMAGE**

**MAXIMUM DEPTH AND REPAIR AREAS ALLOWED**

TYPE OF DAMAGE	Hatched Symbol	Dotted Symbol	White Symbol
CRACKS	None	None	None
MECHANICAL DAMAGE	0.005	0.015	0.030
CORROSION DAMAGE			
Before Repair	0.0025	0.0075	0.015
After Repair	0.005	0.015	0.030
MAXIMUM AREA PER FULL DEPTH REPAIR	0.1 Sq. In.	0.5 Sq. In.	1.0 Sq. In.
NUMBER OF REPAIRS	One Per Area	One Per Area	One Per Area
EDGE CHAMFER	0.02	0.04	0.06
BORE DAMAGE	0.002 for one-fourth circumference		
THREAD DAMAGE	Length	0.25	
	Depth	0.005	
	Number	Three	

ALL DIMENSIONS ARE IN INCHES UNLESS OTHERWISE NOTED

209001-124B

Figure 11-32. Damage Limits - Anti-Torque System (Sheet 1 of 7)

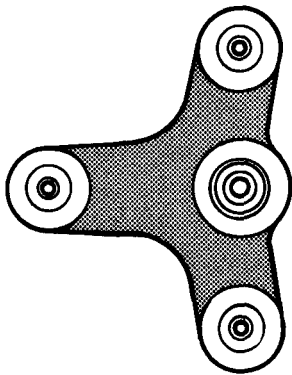

BELLCRANK  
209-001-706

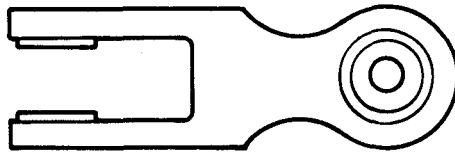

LINK  
209-001-707

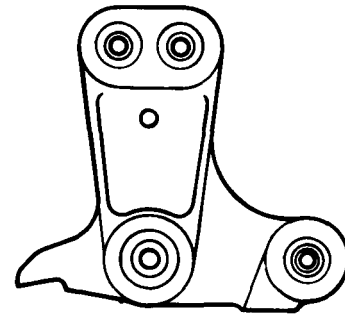

BELLCRANK  
209-001-708

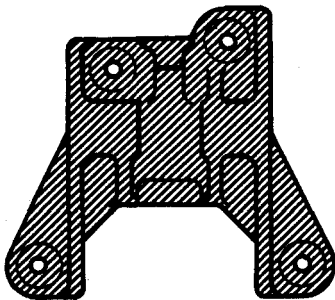

SUPPORT  
209-001-709

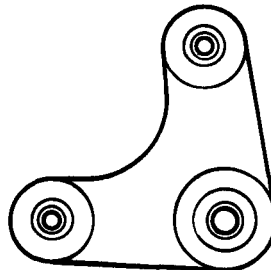

BELLCRANK  
209-001-710

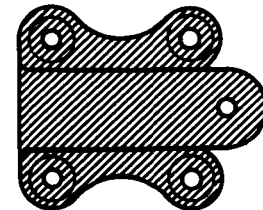

SUPPORT  
209-001-711

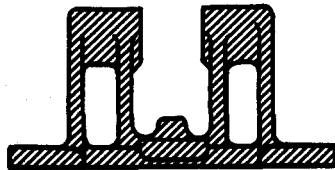

DAMAGE LOCATION SYMBOLS



TYPE OF DAMAGE

MAXIMUM DEPTHS AND REPAIR AREAS ALLOWED

<u>TYPE OF DAMAGE</u>	<u>MAXIMUM DEPTHS AND REPAIR AREAS ALLOWED</u>	<u>MAXIMUM DEPTHS AND REPAIR AREAS ALLOWED</u>	<u>MAXIMUM DEPTHS AND REPAIR AREAS ALLOWED</u>
CRACKS	None	None	None
MECHANICAL DAMAGE	0.005	0.015	0.030
CORROSION DAMAGE			
Before Repair	0.0025	0.0075	0.015
After Repair	0.005	0.015	0.030
MAXIMUM AREA PER FULL DEPTH REPAIR	0.1 Sq. In.	0.05 Sq. In.	1.0 Sq. In.
NUMBERS OF REPAIRS	1 Per Area	1 Per Area	1 Per Area
EDGE CHAMFER	0.02	0.04	0.06
BORE DAMAGE	0.002 for 1/4 Circumference		

ALL DIMENSIONS IN INCHES UNLESS OTHERWISE NOTED. 209001-127B

Figure 11-32. Damage Limits - Anti-Torque System (Sheet 2 of 7)

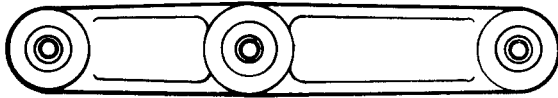

WALKING BEAM  
209-001-712

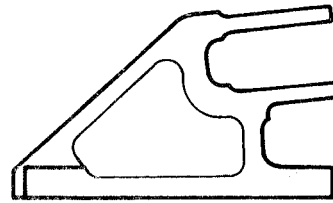

SUPPORT  
209-001-713

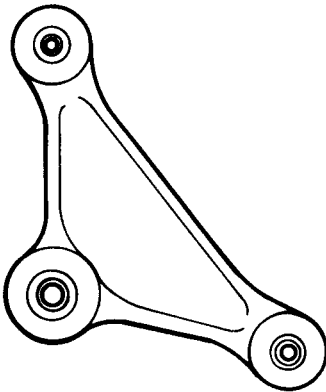

BELLCRANK  
209-001-714

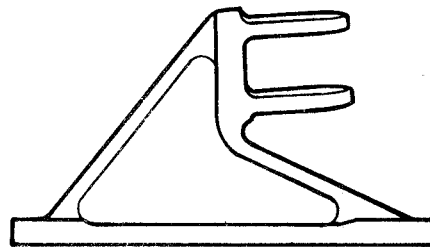

SUPPORT  
209-001-715

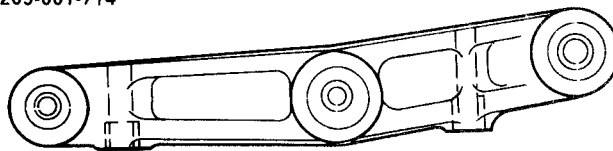

WALKING BEAM  
209-001-720

<u>TYPE OF DAMAGE</u>	<u>MAXIMUM DEPTHS AND REPAIR AREAS ALLOWED</u>
CRACKS	None
MECHANICAL DAMAGE	0.030
CORROSION DAMAGE	
Before Repair	0.015
After Repair	0.030
MAXIMUM AREA PER FULL DEPTH REPAIR	1.0 Sq. In.
NUMBER OF REPAIRS	1 Per Area
EDGE CHAMFER	0.06
BORE DAMAGE	0.002 for 1/4 Circumference

ALL DIMENSIONS ARE IN INCHES UNLESS OTHERWISE NOTED.

209001-126B

Figure 11-32. Damage Limits - Anti-Torque System (Sheet 3 of 7)

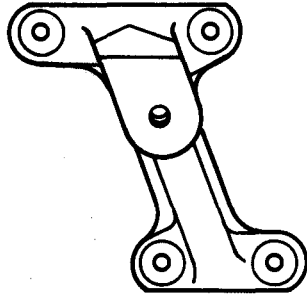

SUPPORT  
209-001-717



LEVER  
209-001-718

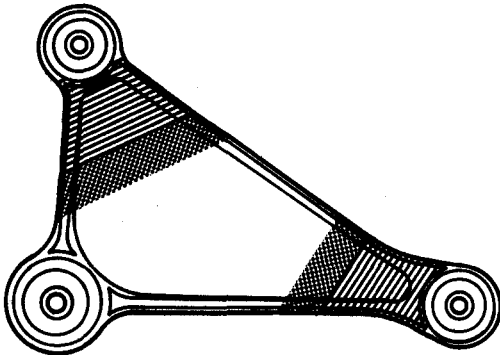

BELLCRANK  
209-001-754

DAMAGE LOCATION SYMBOLS



TYPE OF DAMAGE

MAXIMUM DEPTH AND REPAIR AREAS ALLOWED

CRACKS	None	None	None
MECHANICAL DAMAGE	0.005	0.015	0.030
CORROSION DAMAGE			
Before Repair	0.0025	0.0075	0.015
After Repair	0.005	0.015	0.030
MAXIMUM AREA PER FULL DEPTH REPAIR	0.1 Sq. In.	0.5 Sq. In.	1.0 Sq. In.
NUMBER OF REPAIRS	One Per Area	One Per Area	One Per Area
EDGE CHAMFER	0.02	0.04	0.06
BORE DAMAGE	0.002 for one-fourth circumference		

ALL DIMENSIONS ARE IN INCHES UNLESS OTHERWISE NOTED

209001-125B

Figure 11-32. Damage Limits - Anti-Torque System (Sheet 4 of 7)

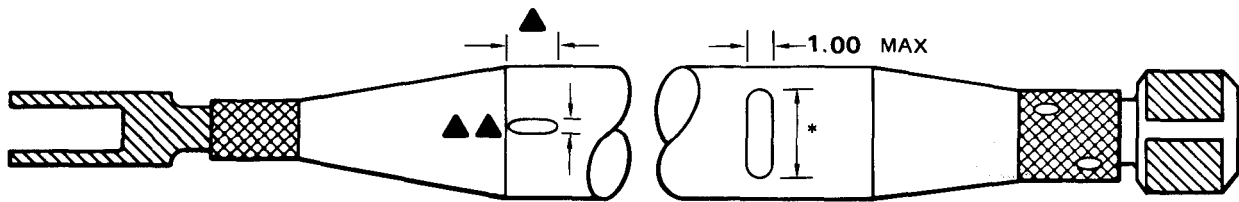

**LIMITS FOR SMOOTH DENTS ONLY**

- ▲ 1.00 inch maximum length of dent in direction of tube length.
- ▲▲ Maximum diameter of dent must not exceed 0.2 times outer tube diameter.

**DAMAGE LOCATION SYMBOLS**



**TYPE OF DAMAGE**

**MAXIMUM DEPTHS AND REPAIR AREAS ALLOWED**

CRACKS	None	None	None
MECHANICAL DAMAGE	No Damage Allowed	0.005	↑ See table below ↓
CORROSION DAMAGE		0.0025	
Before Repair		0.005	
After Repair			
MAXIMUM AREA PER FULL DEPTH REPAIR		0.1 Sq. In.	
NUMBER OF REPAIRS	————— One Per Area —————		
EDGE CHAMFER		0.02	
BORE DAMAGE	0.002 for one-fourth circumference		

LENGTH OF CIRCUMFERENCE (*) OVER WHICH REPAIR PERMITTED	0.25	25%	50%
Maximum Depth of:			
Corrosion Damage before Cleanup (**)	0.002	0.0015	0.001
Mechanical and Corrosion Repair after Cleanup (**)	0.004	0.003	0.002

\*\* Values shown for a 0.035 wall thickness, in no case will the mechanical and corrosion depth after cleanup exceed 10% of the tube wall thickness, nor corrosion depth before cleanup exceed 5% of the tube wall thickness.

ALL DIMENSIONS ARE IN INCHES UNLESS OTHERWISE NOTED

209001-136A

Figure 11-32. Damage Limits - Anti-Torque System (Sheet 5 of 7)

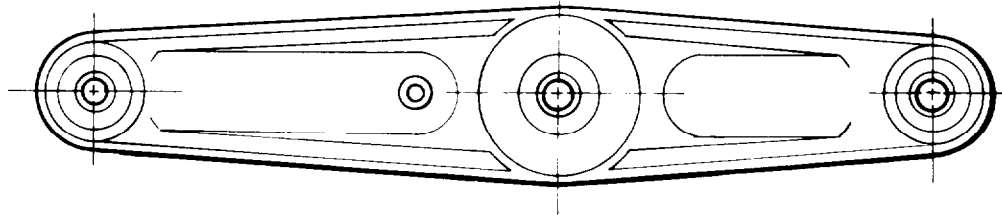

WALKING BEAM  
209-001-761

<u>TYPE OF DAMAGE</u>	<u>MAXIMUM DEPTHS AND REPAIR AREAS ALLOWED</u>
CRACKS	None
MECHANICAL DAMAGE	0.010
CORROSION DAMAGE	
Before Repair	0.005
After Repair	0.010
MAXIMUM AREA PER FULL DEPTH REPAIR	Not Critical
NUMBER OF REPAIRS	Not Critical
BORE DAMAGE	0.002 for one-fourth circumference

ALL DIMENSIONS ARE IN INCHES UNLESS OTHERWISE NOTED

209001-137A

Figure 11-32. Damage Limits – Anti-Torque System (Sheet 6 of 7)

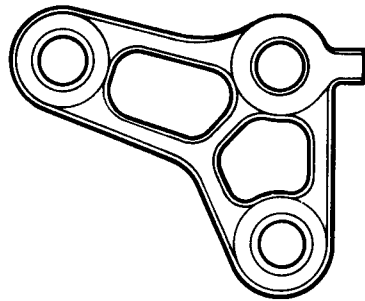

209-001-764 BELLCRANK

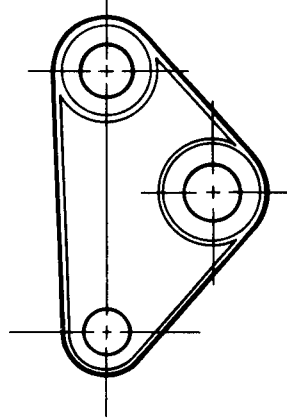

209-001-762 BELLCRANK

TYPE OF DAMAGE

MAXIMUM DEPTHS  
AND REPAIR AREAS ALLOWED

CRACKS	NONE
MECHANICAL DAMAGE	0.020
CORROSION DAMAGE	
Before repair	0.010
After reappear	0.020
MAXIMUM AREA PER FULL DEPTH REPAIR	Not Critical
NUMBER OF REPAIRS	Not Critical
BORE DAMAGE	0.002 for 1/4 of circumference

ALL DIMENSIONS ARE IN INCHES UNLESS OTHERWISE NOTED

209001-138A

Figure 11-32. Damage Limits - Anti-Torque System (Sheet 7 of 7)

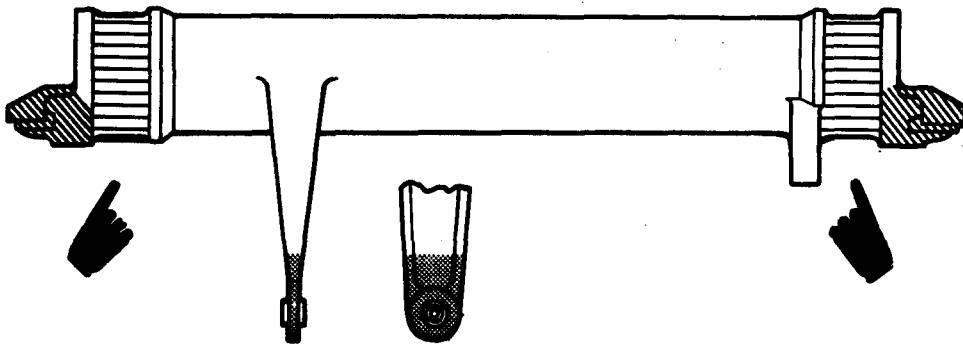

\*ELEVATOR HORN  
209-001-908

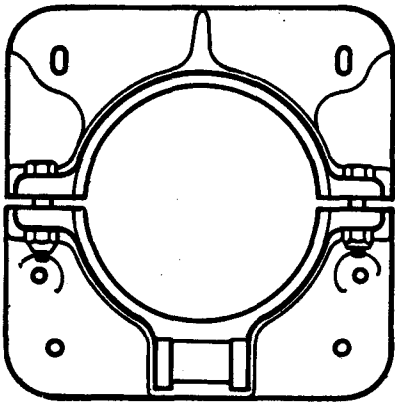

ELEVATOR SUPPORT  
209-030-834-1

NO REPAIR  
TO MATING SURFACES

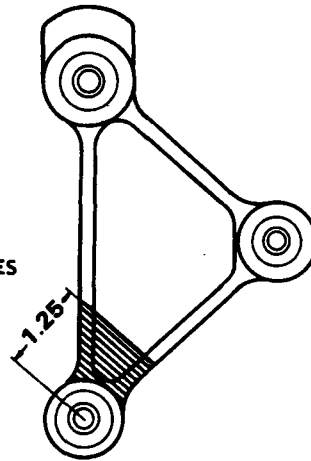

BELLCRANK  
209-001-900







**DAMAGE LOCATION SYMBOLS**



**TYPE OF DAMAGE**

**MAXIMUM DEPTHS AND REPAIR AREAS ALLOWED**

				
<b>CRACKS</b>	None	None	None	None
<b>MECHANICAL DAMAGE</b>	0.005	0.015	0.030	0.005
<b>CORROSION DAMAGE</b>				None
Before Repair	0.0025	0.0075	0.015	
After Repair	0.005	0.015	0.030	
<b>MAXIMUM AREA PER FULL DEPTH REPAIR</b>	0.1 Sq. In.	0.05 In. Sq.	1.0 In. Sq.	None
<b>NUMBERS OF REPAIRS</b>	1 Per Area	1 Per Area	1 Per Area	None
<b>EDGE CHAMFER</b>	0.02	0.04	0.06	
<b>BORE DAMAGE</b>	0.002 for 1/4 Circumference			
Minimum Outside Diameter				3.2475

ALL DIMENSIONS IN INCHES UNLESS OTHERWISE NOTED.

209001-129

\*Elevator horn will become polished which is considered "Normal Wear". Normal wear is permitted.

Figure 11-33. Damage Limits - Elevator Control System (Sheet 1 of 2)





WALKING BEAM  
209-001-905

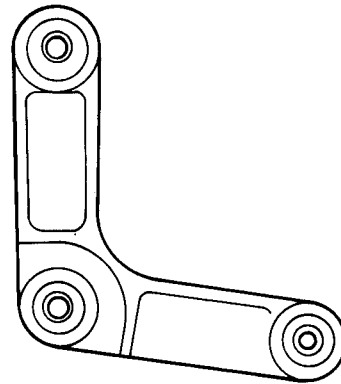

BELLCRANK  
209-001-901

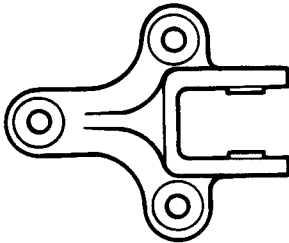

SUPPORT  
209-001-906

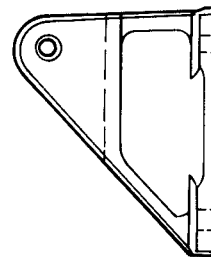

SUPPORT  
209-001-902

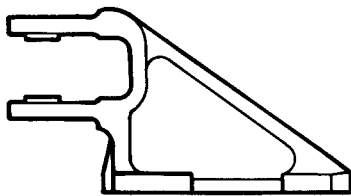

SUPPORT  
209-001-904

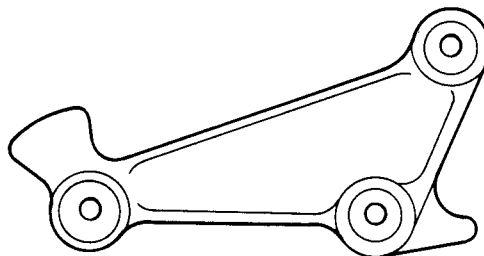

BELLCRANK  
209-001-903

**TYPE OF DAMAGE**

**MAXIMUM DEPTHS AND REPAIR AREAS ALLOWED**

**CRACKS**

**None**

**MECHANICAL DAMAGE**

**0.030**

**CORROSION DAMAGE**

Before Repair

**0.015**

After Repair

**0.030**

**MAXIMUM AREA PER  
FULL DEPTH REPAIR**

**1.0 Sq. In**

**NUMBER OF REPAIRS**

**1 Per area**

**EDGE CHAMFER**

**0.06**

**BORE DAMAGE**

**0.002 for 1/4 Circumference**

**ALL DIMENSIONS ARE IN INCHES UNLESS OTHERWISE NOTED.**

209001-128B

Figure 11-33. Damage Limits - Elevator Control System (Sheet 2 of 2)

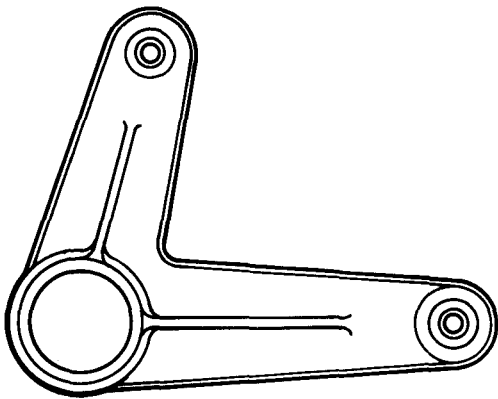

LEVER  
209-001-115

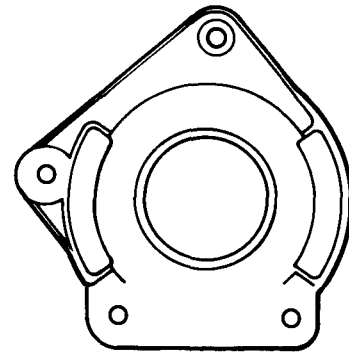

SUPPORT  
209-001-103

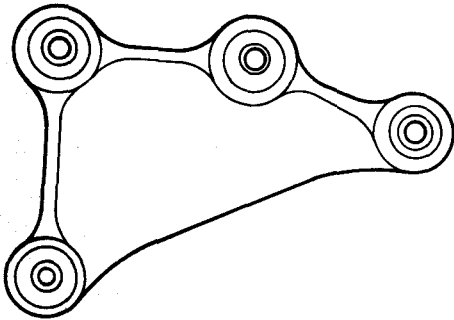

BELLCRANK  
209-001-107

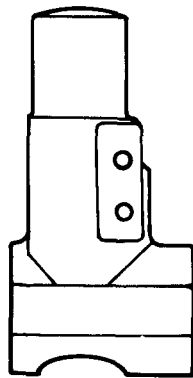

ELBOW  
209-001-118

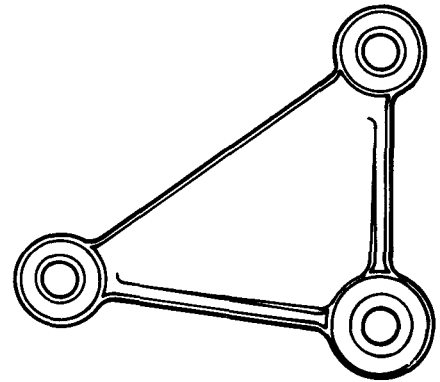

BELLCRANK  
209-001-105

**TYPE OF DAMAGE**

**MAXIMUM DEPTHS AND REPAIR AREAS ALLOWED**

**CRACKS**

**None**

**MECHANICAL DAMAGE**

**0.030**

**CORROSION DAMAGE**

**Before Repair**

**0.015**

**After Repair**

**0.030**

**MAXIMUM AREA PER  
FULL DEPTH REPAIR**

**1.0 Sq. In.**

**NUMBER OF REPAIRS**

**1 per area**

**EDGE CHAMFER**

**0.06**

**BORE DAMAGE**

**0.002 for 1/4 Circumference**

**ALL DIMENSIONS ARE IN INCHES UNLESS OTHERWISE NOTED.**

209001-130B

Figure 11-34. Damage Limits - Collective Control System (Sheet 1 of 6)

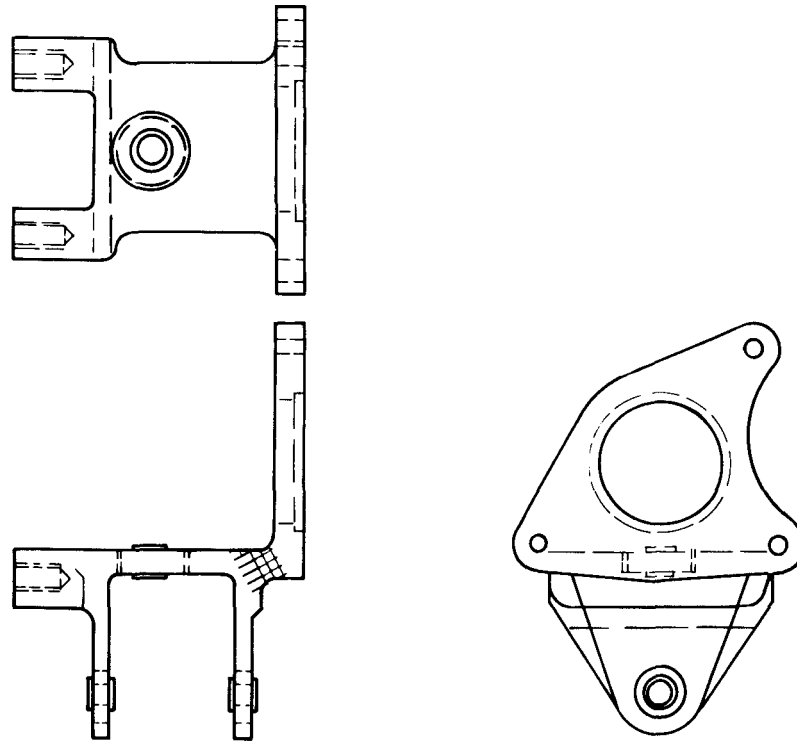

SUPPORT  
209-001-102

DAMAGE LOCATION SYMBOLS



MAXIMUM DEPTHS  
AND REPAIR AREAS ALLOWED

TYPE OF DAMAGE	MAXIMUM DEPTHS AND REPAIR AREAS ALLOWED		
	NONE	NONE	NONE
CRACKS	NONE	NONE	NONE
MECHANICAL DAMAGE	0.005	0.015	0.030
CORROSION DAMAGE			
Before repair	0.0025	0.0075	0.015
After repair	0.005	0.015	0.030
MAXIMUM AREA PER FULL			
DEPTH REPAIR	0.1 Sq. In.	0.5 Sq. In.	1.0 Sq. In.
NUMBER OF REPAIRS		One per area	
EDGE CHAMFER	0.02	0.04	0.06
BORE DAMAGE	0.0C2 for 1/4 of circumference		

ALL DIMENSIONS ARE IN INCHES UNLESS OTHERWISE NOTED

209001-143A

Figure 11-34. Damage Limits - Collective Control System (Sheet 2 of 6)

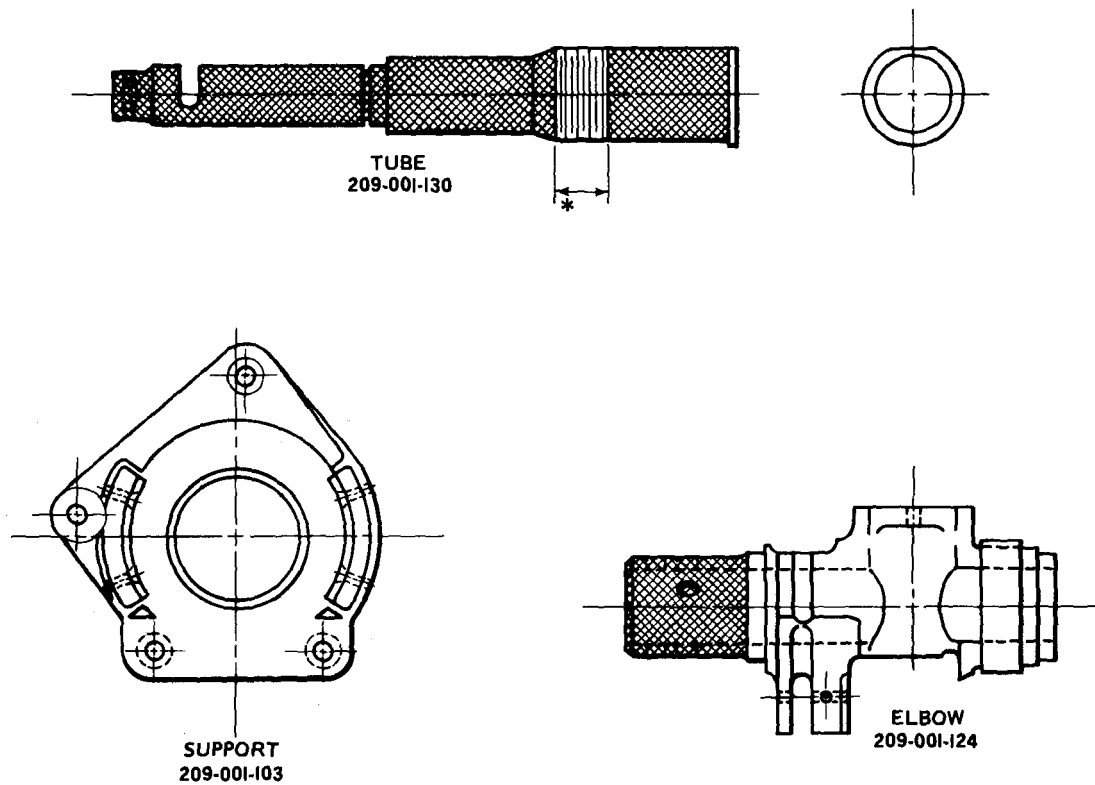

**DAMAGE LOCATION SYMBOLS**



**MAXIMUM DEPTHS AND REPAIR AREAS ALLOWED**

**TYPE OF DAMAGE**

CRACKS	NONE	NONE
MECHANICAL DAMAGE	0.005	0.030
CORROSION DAMAGE		
Before repair	0.0025	0.015
After repair	0.005	0.030
MAXIMUM AREA PER FULL DEPTH REPAIR	0.1 Sq. In.	1.0 Sq. In.
NUMBER OF REPAIRS		One par area
EDGE CHAMFER	0.2	0.6
BORE DAMAGE	0.2 for 1/4 of circumference	

\* NO THREAD DAMAGE IS ACCEPTABLE.

ALL DIMENSIONS ARE IN INCHES UNLESS OTHERWISE NOTED

209001-139A

Figure 11-34. Damage Limits - Collective Control System (Sheet 3 of 6)

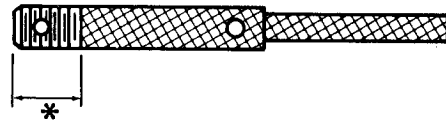

SHAFT  
204-001-258

**DAMAGE LOCATION SYMBOLS**



**TYPE OF DAMAGE**

**MAXIMUM DEPTHS  
AND REPAIR AREAS ALLOWED**

CRACKS	NONE
MECHANICAL DAMAGE	0.005
CORROSION DAMAGE	
Before repair	0.0025
After repair	0.005
MAXIMUM AREA PER FULL DEPTH REPAIR	0.1 Sq. In.
NUMBER OF REPAIRS	One per area
EDGE CHAMFER	
BORE DAMAGE	

**\*NO THREAD DAMAGE IS ACCEPTABLE**

**ALL DIMENSIONS ARE IN INCHES UNLESS OTHERWISE NOTED**

209001-142A

Figure 11-34. Damage Limits - Collective Control System (Sheet 4 of 6)

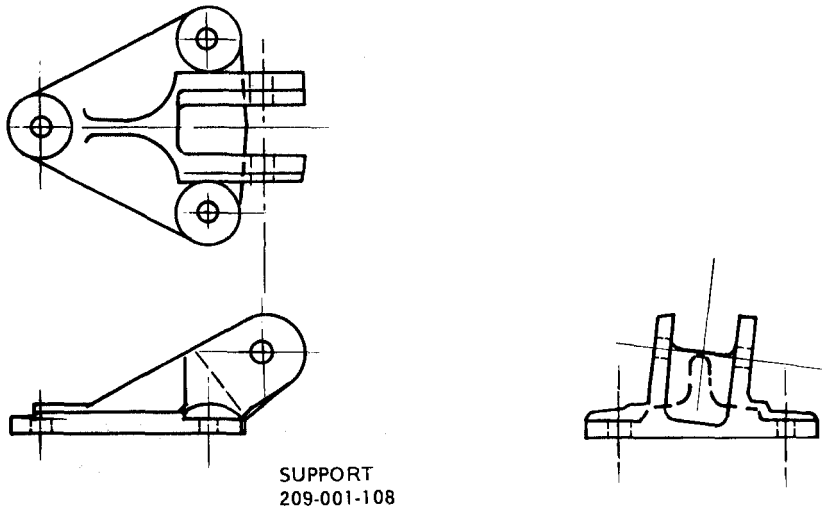

<u>TYPE OF DAMAGE</u>	<u>MAXIMUM DEPTHS AND REPAIR AREAS ALLOWED</u>
CRACKS	None
MECHANICAL DAMAGE	0.030
CORROSION DAMAGE	
Before repair	0.015
After repair	0.030
AREA OF FULL DEPTH REPAIR	1.0 Sq. In.
NUMBER OF REPAIRS	One per area
EDGE CHAMFER	0.06
BORE DAMAGE	0.002 for 1/4 of circumference

ALL DIMENSIONS ARE IN INCHES UNLESS OTHERWISE NOTED

209001-146A

Figure 11-34. Damage Limits -Collective Control System (Sheet 5 of 6)

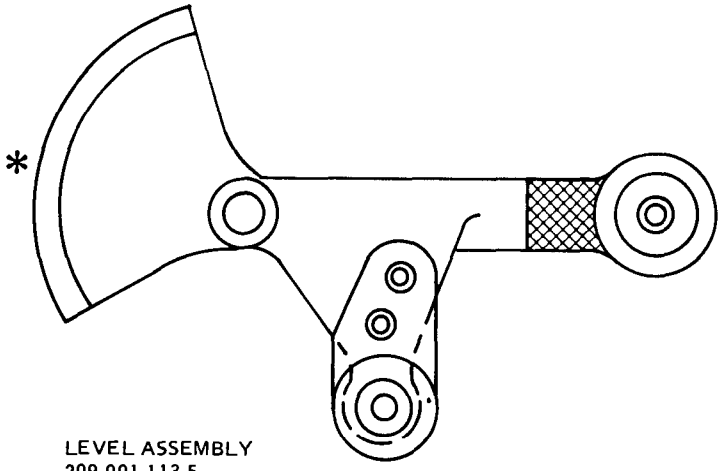

**DAMAGE LOCATION SYMBOLS**



**TYPE OF DAMAGE**

**MAXIMUM DEPTHS AND REPAIR AREAS ALLOWED**

CRACKS	NONE	NONE
MECHANICAL DAMAGE	0.005	0.030
CORROSION DAMAGE		
Before repair	0.0025	0.015
After repair	0.005	0.030
MAXIMUM AREA PER FULL DEPTH REPAIR	0.1 Sq. In.	1.0 Sq. In.
NUMBER OF REPAIRS	One per area	
EDGE CHAMFER	0.02	0.06
BORE DAMAGE	0.02 for 1/4 of circumference	

\* NO THREAD DAMAGE IS ACCEPTABLE.

ALL DIMENSIONS ARE IN INCHES UNLESS OTHERWISE NOTED

209001-145A

Figure 11-34. Damage Limits - Collective Control System (Sheet 6 of 6)

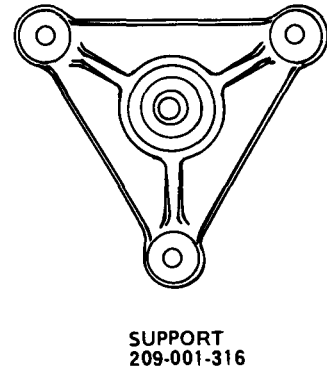
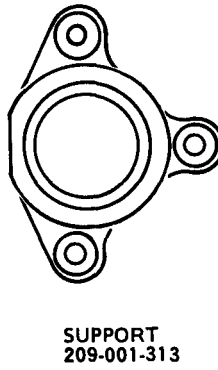
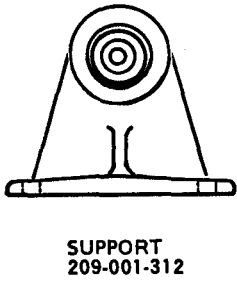
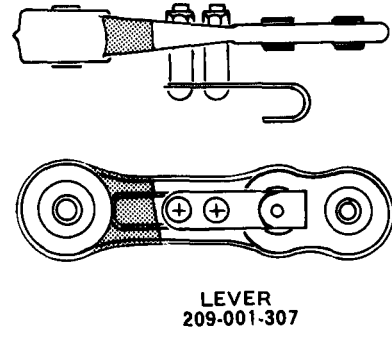
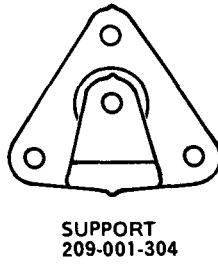
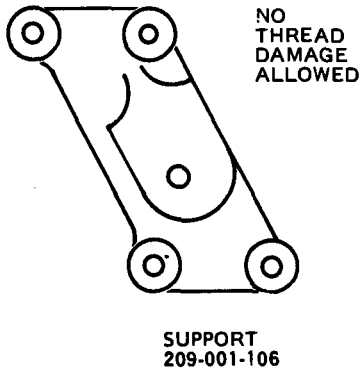

**DAMAGE LOCATION SYMBOLS**



**TYPE OF DAMAGE**

**MAXIMUM DEPTHS AND REPAIR AREAS ALLOWED**

**CRACKS**

NONE

NONE

**MECHANICAL DAMAGE**

0.015

0.030

**CORROSION DAMAGE**

**Before Repair**

0.0075

0.015

**After Repair**

0.015

0.030

**MAXIMUM AREA PER  
FULL DEPTH REPAIR**

0.5 SQ IN

1.0 SQ IN

**NUMBER OF REPAIRS**

1 PER AREA

1 PER AREA

**EDGE CHAMFER**

0.04

0.06

**BORE DAMAGE**

0.002 For 1/4 Circumference

**ALL DIMENSIONS ARE INCHES UNLESS OTHERWISE NOTED**

209001-131-1B

Figure 11-36. Damage Limits - Cyclic Control System (Sheet 1 of 5)



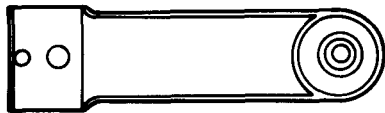

BELLCRANK  
209-001-318

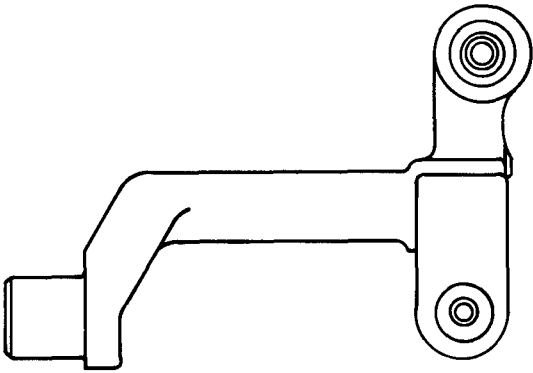

STICK  
209-001-320

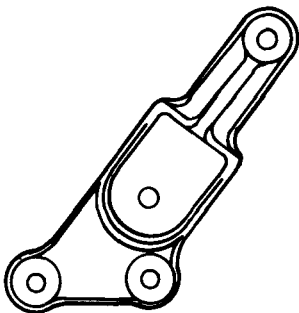

SUPPORT  
209-001-322

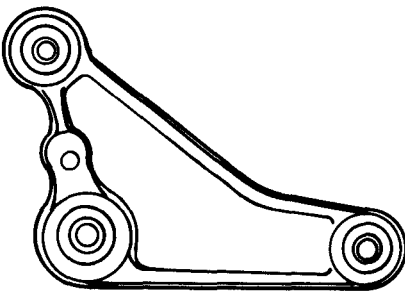

BELLCRANK  
290-001-324

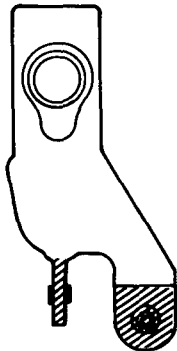

LEVER  
209-001-326

**DAMAGE LOCATION SYMBOLS**



**TYPE OF DAMAGE**

**MAXIMUM DEPTHS AND REPAIR AREAS ALLOWED**

**CRACKS**

NONE

NONE

**MECHANICAL DAMAGE**

0.005

0.030

**CORROSION DAMAGE**

**Before Repair**

0.0025

0.015

**After Repair**

0.005

0.030

**MAXIMUM AREA PER FULL DEPTH REPAIR**

0.1 SQ IN

1.0 SQ IN

**NUMBER OF REPAIRS**

1 PER AREA

1 PER AREA

**EDGE CHAMFER**

0.02

0.06

**BORE DAMAGE**



0.002 For 1/4 Circumference

ALL DIMENSIONS ARE INCHES UNLESS OTHERWISE NOTED

209001-131-2B

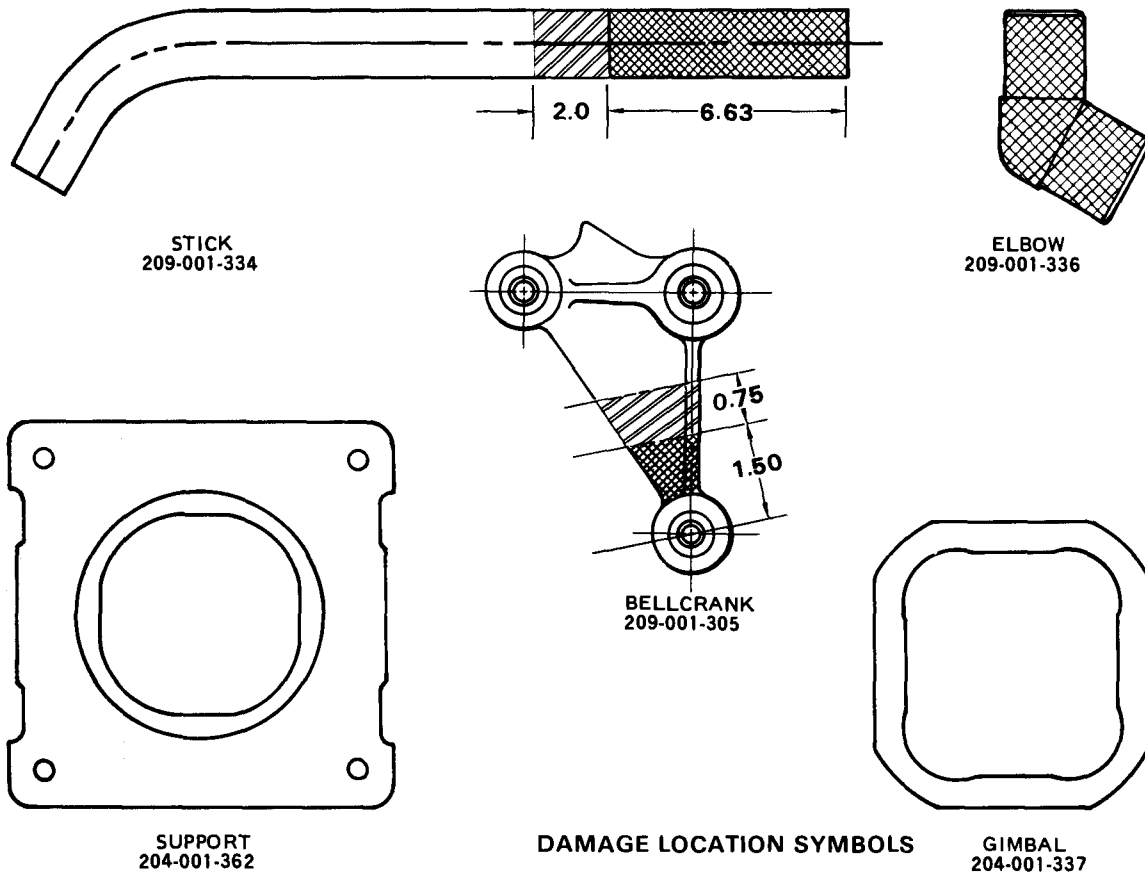
Figure 11-35. Damage Limits - Cyclic Control System (Sheet 2 of 5)



TYPE OF DAMAGE	DAMAGE LOCATION SYMBOLS		
			
	MAXIMUM DEPTHS AND REPAIR AREAS ALLOWED		
CRACKS	NONE	NONE	NONE
MECHANICAL DAMAGE	0.005	0.015	0.030
CORROSION DAMAGE			
Before Repair	0.0025	0.015	0.015
After Repair	0.005	0.015	0.030
MAXIMUM AREA PER FULL DEPTH REPAIR	0.1 SQ IN	0.5 SQ IN	1.0 SQ IN
NUMBER OF REPAIRS	1 PER AREA	1 PER AREA	1 PER AREA
EDGE CHAMFER	0.02	0.04	0.06
BORE DAMAGE	0.002 For 1/4 Circumference		

ALL DIMENSIONS ARE INCHES UNLESS OTHERWISE NOTED

209001-131-3B

Figure 11-35. Damage Limits - Cyclic Control System (Sheet 3 of 5)

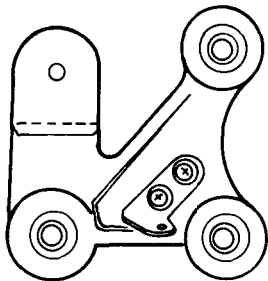

BELLCRANK  
209-001-505

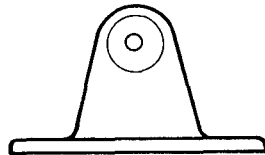

SUPPORT  
209-001-507

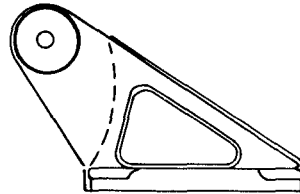

SUPPORT  
209-001-508

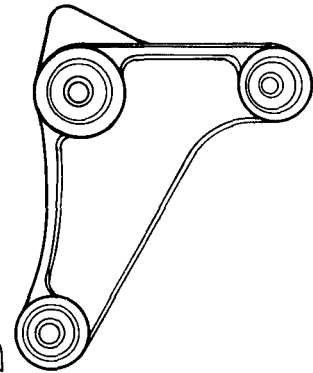

BELLCRANK  
209-001-510

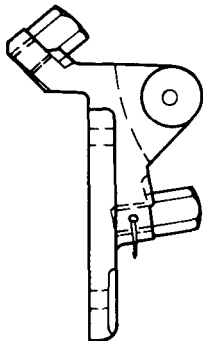

BELLCRANK SUPPORT  
209-001-303

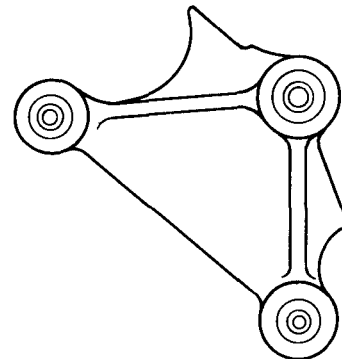
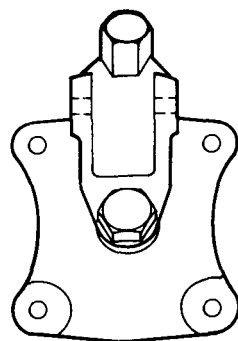

BELLCRANK  
209-001-501

TYPE OF DAMAGE	MAXIMUM DEPTHS AND REPAIR AREAS ALLOWED
CRACKS	NONE
MECHANICAL DAMAGE	0.030
CORROSION DAMAGE	
Before Repair	0.015
After Repair	0.030
MAXIMUM AREA PER FULL DEPTH REPAIR	0.1 SQ. IN.
NUMBER OF REPAIRS	1 PER AREA
EDGE CHAMFER	0.06
BORE DAMAGE	0.002 for 1/4 Circumference

ALL DIMENSIONS ARE IN INCHES UNLESS OTHERWISE NOTED

209001-131-4B

Figure 11-35. Damage Limits - Cyclic Control System (Sheet 4 of 5)

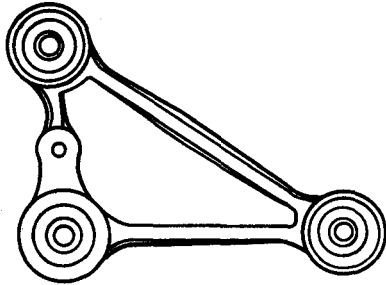

BELLCRANK  
209-001-514

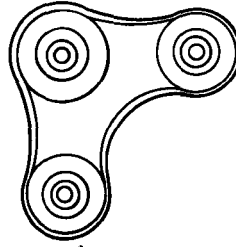

BELLCRANK  
209-001-518

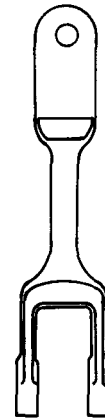

LINK  
209-001-520

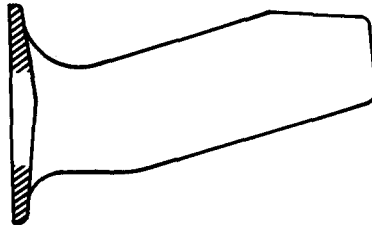

SUPPORT  
209-001-522

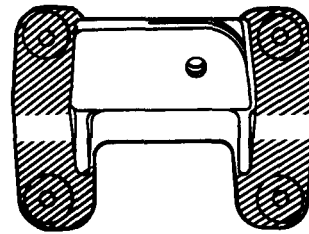

**DAMAGE LOCATION SYMBOLS**



**TYPE OF DAMAGE**

**MAXIMUM DEPTHS AND REPAIR AREAS ALLOWED**

CRACKS	NONE	NONE
MECHANICAL DAMAGE	0.005	0.030
CORROSION DAMAGE		
Before Repair	0.0025	0.015
After Repair	0.005	0.030
MAXIMUM AREA PER FULL DEPTH REPAIR	0.1 SQ IN	1.0 SQ IN
NUMBER OF REPAIRS	1 PER AREA	1 PER AREA
EDGE CHAMFER	0.02	0.06
BORE DAMAGE	0.002 FOR CIRCUMFERENCE	

ALL DIMENSIONS ARE IN INCHES UNLESS OTHERWISE NOTED

209001-131-5B

Figure 11-35. Damage Limits - Cyclic Control System (Sheet 5 of 5)

Secure nut with cotter pin (63). Attach support to airframe with bolts (66) and washers (65). Attach longest hook of spring (23, figure 11-12) to idler crank and attach opposite end to fuselage.

e. Install remaining supports with bolts and washers.

**NOTE**

**Lateral and fore-and-aft supports (49 and 80, figure 11-31) require nuts on aft bolts. Tail rotor supports (111 and 124) require a nut on lower bolt.**

f. Install lateral bellcrank (45), fore-and-aft bellcrank (76), tail rotor bellcrank (119), and collective bellcrank (6) in supports with bolts (8, 57, and 94) and washers (7, 56, and 95). Secure bolts to supports with lockwire (C138).

g. Install remaining bellcranks, levers, and walking beams in supports with bolts, washers, and nuts. Install one washer under bolt head and one washer under nut.

h. Connect spring (67) to longitudinal idler crank (60) and springs (32) to lateral bellcrank (33).

i. Connect tail rotor force gradient (paragraph 11-97).

j. Connect cyclic force gradient (paragraph 11-87).

k. Connect SCAS transducers (paragraph 11-96).

l. Connect droop compensator control tube (12) (paragraph 4-112).

m. Install SCAS servo actuators (46, 77, and 143) (paragraph 7-74).

n. Install dual hydraulic cylinders (paragraph 7-63).

o. Install flight control tubes and links (paragraph 11-152).

p. Install components that were removed to gain access to flight controls.

q. Ensure that all safetying devices (cotter pins and lockwire) are installed in the flight control system being repaired.

r. Move controls through full throw and ensure that there is no binding or interference.

s. Install access panels.

**11-160. OPERATIONAL CHECK - BELLCRANKS, CONTROL TUBES, AND LINKS.**

Perform maintenance test flight.

**11-161. BEARINGS - CYCLIC, COLLECTIVE, ANTI-TORQUE, AND SYNCHRONIZED ELEVATOR SYSTEMS.**

**11-162. DESCRIPTION - BEARINGS - CYCLIC, COLLECTIVE, ANTI-TORQUE, AND SYNCHRONIZED ELEVATOR SYSTEMS.**

Bearings are installed in force gradient rod ends, bellcranks, levers, and other components of the control systems. Inspect and replace in accordance with this paragraph and with TM 55-1 500-204-25/1.

**Premaintenance Requirements for Bearings - Cyclic, Collective Anti-Torque and Synchronized Elevator Systems**

Conditions	Requirements
Model	AH-1S
Part No. or Serial No.	All
Special Tools	(T61)
Test Equipment	None
Support Equipment	Drill Press, Arbor Press, Roll Staking Tool
Minimum Personnel Required	Two
Consumable Materials	(C30), (C31), (C74), (C75), (C79), (C88), (C96), (C102)
Special Environmental Conditions	None

**11-163. REMOVAL - BEARINGS - CYCLIC, COLLECTIVE, ANTI-TORQUE, AND SYNCHRONIZED ELEVATOR SYSTEMS.**

- a. Remove the flight control system part the bearing is installed in . Refer to paragraph 11-149 or 11-156 as applicable.
- b. Refer to paragraph 11-165 for procedures to remove bearing from flight control system parts.

**11-164. INSPECTION - BEARINGS - CYCLIC, COLLECTIVE, ANTI-TORQUE, AND SYNCHRONIZED ELEVATOR SYSTEMS.**

- a. Inspect bearings visually for obvious mechanical damage, corrosion and for secure installation.
- b. Rotate bearings and check for binding and roughness. Binding or roughness that can be detected by feel is cause to replace the affected bearing.
- c. Inspect bearings for wear. Maximum acceptable wear (looseness) is as follows:

**(1) Force gradient rod ends:**

- 0.012** inch radial
- 0.030** inch axial

**(2) Pivot bearings in bellcranks, levers, walking beams, and pedals.**

- 0.005** inch radial
- 0.030** inch axial

**(3) Rod end bearings on dual hydraulic cylinder and control tube assemblies and bearings other than pivots in bellcranks, levers, walking beams, pedal links, stick assemblies, jackshaft, and elevator horn:**

- 0.012** inch radial
- 0.030** inch axial

**11-165. REPAIR - BEARINGS - CYCLIC, COLLECTIVE, ANTI-TORQUE AND SYNCHRONIZED ELEVATOR SYSTEMS.**

**NOTE**

**Repair consists of replacing faulty bearings or the part containing the bearing.**

- a. Replace rod end bearings (figure 11-36, detail C) as the unit. If the rod end bearing is bonded to the part, replace the entire part.

- b. Do not replace individual bearings that have been installed in figure 11-36, detail A. This type bearing has a chamfered outer race. Parent metal of the part the bearing is installed in is forced over the bearing chamfer by segment staking or roll staking. When bearings that have been installed by this method fail to pass inspection, replace the part containing the bearing.

- c. Bearings which have been roll staked by forcing the bearing outer race or bearing sleeve over the chamfer at the part containing the bearing as shown on figure 11-36, detail B, can be replaced as follows:

- (1)** Place housing over suitable support with clearance for bearing. Press on outer race to remove bearing. Refer to TM 55-1500-204-25/1.



Cleaning solvent is flammable and toxic, Provide adequate ventilation. Avoid prolonged breathing of solvent vapors and contact with skin or eyes.

- (2)** Clean housing with cheesecloth (C30) and MEK (C74).

- (3)** Inspect housing bore for damage. Maximum acceptable bore damage is **0.002** inch deep for one-fourth of circumference.

- (4)** Remove burrs and light scoring from bore and from chamfer with **320** grit or finer sandpaper (C102).

- (5)** Inspect housing by fluorescent penetrant method. Refer to TM 43-0103. Clean with cheesecloth (C30) and naphtha (C75).

(6) Apply chemical film (C31) to hole in housing. Allow to dry one to three minutes. Rinse with water. Dry with cloth or force dry.

**CAUTION**

**Avoid excessive application of primer.  
Do not allow primer to enter bearing.**

(7) Apply one coat of primer (C88 or C91) to housing hole and bearing outer race just prior to installation.

**CAUTION**

**If extreme interference fit occurs at beginning of press operation, stop and determine cause before proceeding. Do not install bearing with extreme interference fit as it will cause bearing to bind.**

(8) Press bearing into housing hole while primer is still wet. Ensure bearing is started square and not cocked.

**CAUTION**

**Use steady hand pressure on drill during roll staking procedure. Excessive pressure may result in reduction of the outer lip metal thickness adjacent to the 0.008 inch dimension on figure 11-36, detail B.**

(9) Roll or ring stake pregrooved bearings. Use tool set (T-61 or T-61.1) to stake bearings. For roll staked bearings, attach tool set to a stand-type drill press. Operate drill press **250 to 350** rpm. Support bearing on lower part of tool and roll stake outer lip of bearing race over housing. Apply reasonably steady hand pressure on drill press for a minimum of ten seconds to allow staking tool to flow metal out. Apply oil (C79) sparingly and cautiously to staking tool rolls. Remove all oil immediately after staking. Refer to TM 55-1500-322-24 for complete bearing replacement.

(10) Inspect installed bearing as follows:

(a) Inspect for gap between chamfer on housing and lip on bearing race. Maximum acceptable gap is **0.008** inch as shown in figure 11-36, detail B.

(b) Inspect bearing for cocking. The bearing must be square to the housing surface.

(c) Rotate bearing and check for binding and roughness by feel.

(d) Inspect for looseness between race and housing. There must be no evidence of bearing walking or looseness.

(e) Inspect housing by dye penetrant method. Refer to TM 43-0103.

**11-166. INSTALLATION - BEARINGS - CYCLIC, COLLECTIVE, ANTI-TORQUE, AND SYNCHRONIZED ELEVATOR SYSTEMS.**

a. Install bearing in or on next higher assembly part as applicable (paragraph 11-165).

b. After bearing is assembled on next higher assembly part, install the part in the helicopter. Refer to paragraph 11-144, 11-152, or 11-159 as applicable.

**11-167. POWER CYLINDER SUPPORTS - LATERAL CYCLIC, FORWARD AND AFT CYCLIC, AND COLLECTIVE SYSTEMS.**

**11-168. DESCRIPTION - POWER CYLINDER SUPPORTS, LATERAL CYCLIC, FORWARD-AND-AFT CYCLIC, AND COLLECTIVE SYSTEMS .**

a. The lateral cyclic and collective controls power cylinder support (13, figure 11-37) is mounted at the left side of the transmission bay. It is the supporting member for the two control power cylinders (hydraulic cylinder assemblies) named above.

b. THE FORWARD AND AFT CYCLIC POWER CYLINDER SUPPORT (3, figure 11-38) is mounted at the right side of the transmission bay. It is the supporting member for the forward and aft control power cylinder (hydraulic cylinder assembly).

**11-169. REMOVAL - POWER CYLINDER SUPPORTS, LATERAL CYCLIC, FORE-AND-AFT CYCLIC, AND COLLECTIVE SYSTEMS.**

a. Remove lateral cyclic and collective controls power cylinder support (13, figure 11-39) as follows:

(1) Remove lateral cyclic and collective power cylinder assemblies (paragraph 7-55).

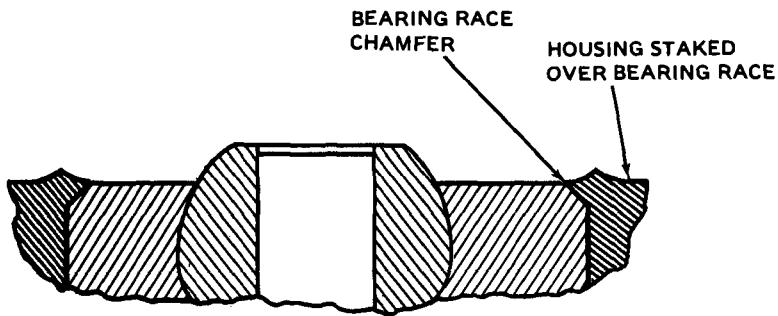

DETAIL A  
BEARING WITH CHAMFER ON OUTER RACE  
(TYPICAL)

NOTE

Bearing replacement  
not recommended.

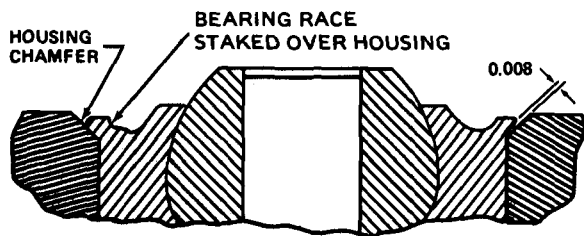

DETAIL B  
PREGROOVED BEARING  
(TYPICAL)

NOTE

Bearing may be replaced.  
Refer to text.

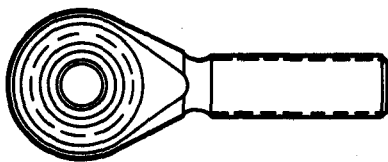

DETAIL C  
ROD END BEARING  
(TYPICAL)

NOTE

Typical rod end bearing  
is replaced as a unit.  
If bonded in, replace  
next assembly.

ALL DIMENSIONS ARE IN INCHES UNLESS OTHERWISE NOTED

Figure 11-36. Flight Control System Bearings



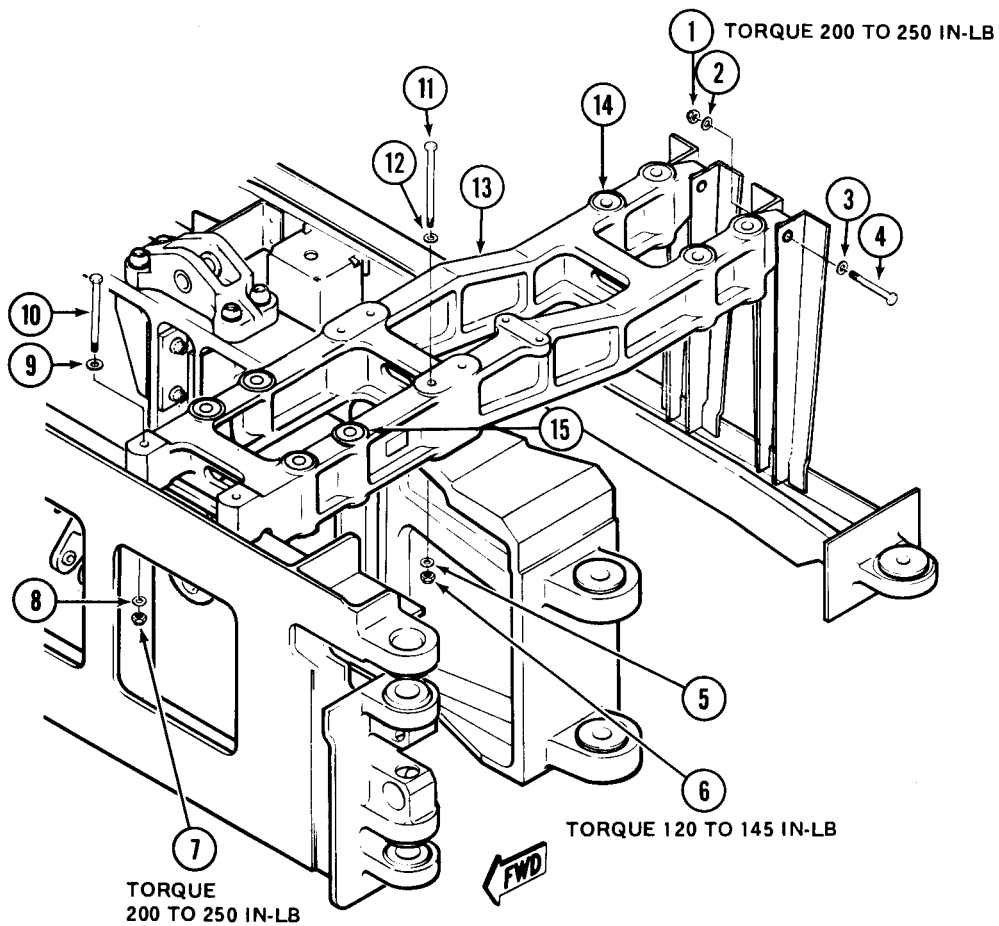

- |           |             |
|-----------|-------------|
| 1. Nut    | 9. Washer   |
| 2. Washer | 10. Bolt    |
| 3. Washer | 11. Bolt    |
| 4. Bolt   | 12. Washer  |
| 5. Washer | 13. Support |
| 6. Nut    | 14. Washer  |
| 7. Nut    | 15. Washer  |
| 8. Washer |             |

210001-107A

Figure 11-37. Lateral Cyclic and Collective Controls Power Cylinder Support installation

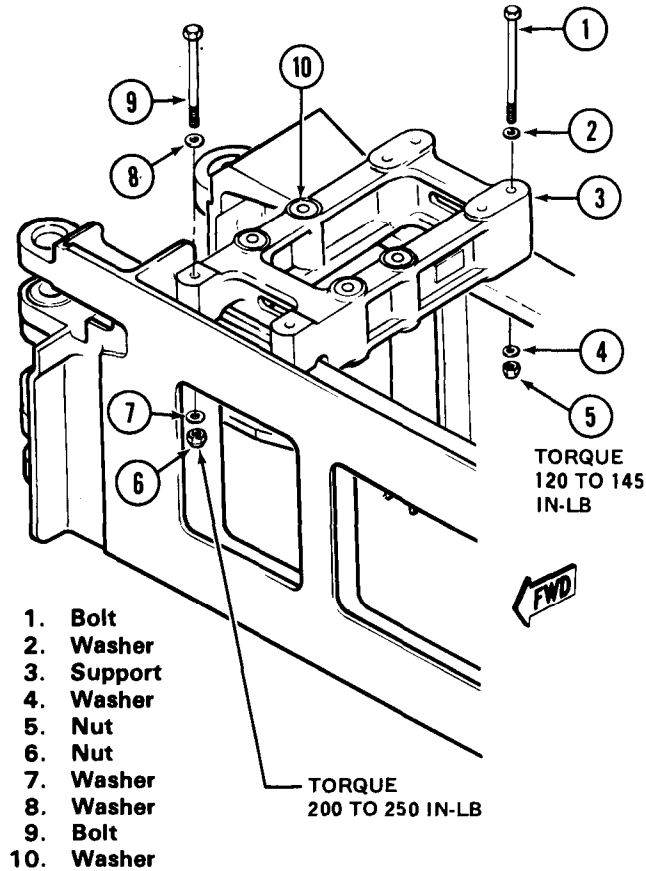

210001-108A

**Figure 11-38. Fore-And-Aft Cyclic Controls Power Cylinder Support Installation**

(2) Remove nuts (6), washers (5 and 12) and four bolts (11) that attach support to lift beam.

(3) Remove nuts (7), washers (8 and 9), and two bolts (10).

(4) Remove nuts (1), washers (2 and 3) and two bolts (4) that attach support to airframe.

(5) Remove support (13).

**b.** Remove fore-and-aft cyclic controls power cylinder support (3, figure 11-38) as follows:

(1) Remove fore-and-aft cyclic power cylinder assembly (paragraph 7-55).

(2) Remove System No. 2 hydraulic pump paragraph 7-23).

(3) Remove nuts (5), washers (2 and 4), and four bolts (1) that attach support (3) to lift beam.

(4) Remove nuts (6), washers (7 and 8), and two bolts (9) that attach support to bulkhead fitting.

(5) Remove support (3).

**11-170. INSPECTION - POWER CYLINDER SUPPORTS, LATERAL CYCLIC, FORE-AND-AFT CYCLIC, AND COLLECTIVE SYSTEMS.**

**a.** Inspect supports for damage in excess of limits shown on figure 11-39.

**b.** Inspect four washers (14 and 15, figure 11-37) and (10, figure 11-38) at each cylinder installation point (total of twelve washers on both supports) for secure bonding to the supports.

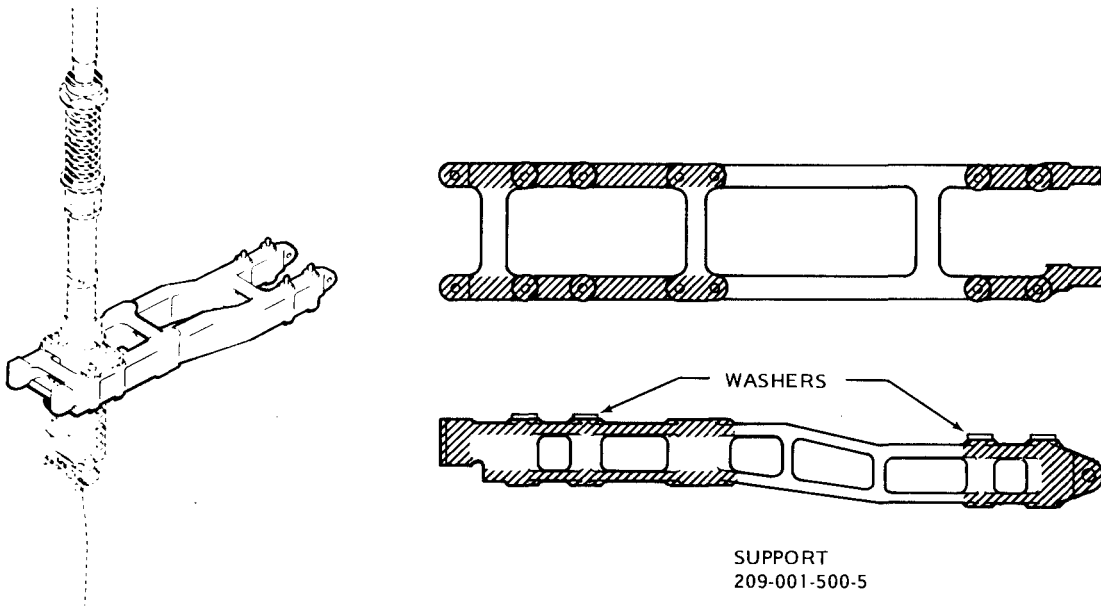

**DAMAGE LOCATION SYMBOLS**



TYPE OF DAMAGE	MAXIMUM DEPTHS AND REPAIR AREAS ALLOWED	
	(Hatched Symbol)	(Empty Symbol)
<b>CRACKS ALLOWED</b>	None	None
<b>MECHANICAL</b>	0.020	0.030
<b>CORROSION</b>	0.010	0.015
<b>MAXIMUM AREA PER FULL DEPTH REPAIR</b>	0.25 Sq. In.	0.50 Sq. In.
<b>NUMBER OF REPAIRS</b>	Two Per Segment	
<b>EDGE CHAMFER</b>	0.040	0.060
<b>BORE DAMAGE</b>	0.002 Inch For 1/4 Circumference	

**ALL DIMENSIONS ARE IN INCHES UNLESS OTHERWISE NOTED**

209001-155-1

**Figure 11-39. Damage Limits - Power Cylinder Supports (Sheet 1 of 2)**

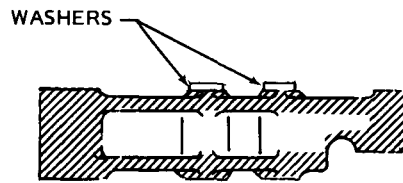
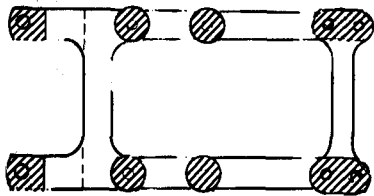

SUPPORT  
209-001-302-3

**DAMAGE LOCATION SYMBOLS**



**TYPE OF DAMAGE**

**MAXIMUM DEPTHS AND REPAIR AREAS ALLOWED**

**CRACKS ALLOWED**

None

None

**MECHANICAL DAMAGE**

0.020

0.030

**CORROSION DAMAGE  
BEFORE CLEANUP  
AFTER CLEANUP**

0.010  
0.020

0.015  
0.030

**AREA OF FULL DEPTH REPAIR**

0.50 Sq. In.

**NUMBER OF REPAIRS**

Not Critical

Not Critical

**EDGE CHAMFER**

0.050

0.060

**BORE DAMAGE**

0.002 Inch for Full Circumference

**ALL DIMENSIONS ARE IN INCHES UNLESS OTHERWISE NOTED**

209001-155-2

Figure 11-39. Damage Limits - Power Cylinder Supports (Sheet 2 of 2)

**11-171. REPAIR - POWER CYLINDER SUPPORTS, LATERAL CYCLIC, FORE-AND-AFT CYCLIC, AND COLLECTIVE SYSTEMS.**

a. Polish out mechanical and corrosion damage that is within limits shown on figure 11-39 with abrasive paper (C102).

b. Touch up repair area with chemical film (C31) and primer (C88 or C91).

**WARNING**

**Cleaning solvent is flammable and toxic. Provide adequate ventilation. Avoid prolonged breathing of solvent vapors and contact with skin or eyes.**

c. (AVIM) Replace missing washers (14 and 15, figure 11-37) and (10, figure 11-38). Clean old adhesive with sandpaper (102). Clean mating surface of washer and support with MEK (C74). Bond washer to support with adhesive (C8). Refer to table 1-11, for adhesive, mix ratio, pot life, and curing schedule.

**11-172. INSTALLATION - POWER CYLINDER SUPPORTS, LATERAL CYCLIC, FORE-AND-AFT CYCLIC, AND COLLECTIVE SYSTEMS.**

a. Install lateral cyclic and collective controls power cylinder support (13, figure 11-37) as follows:

(1) Attach power cylinder support (13) to lift beam with four bolts (11), washers (12 and 5) and nuts (6). Place one washer (12) under bolt head with

countersunk side against head, and one washer (5) under nut. Do not tighten.

(2) Attach support (13) to forward carry-through fitting with two bolts (10), washers (8 and 9), and nuts (7). Place one washer (9) under head with countersunk side against head, and one washer (8) under nut. Attach support to aft bulkhead with bolts (4), washers (2 and 3), and nuts (1). Place one washer (3) under head with countersunk side against head, and one washer (2) under nut (1).

(3) Torque nuts (6) **120 TO 145** inch-pounds. Torque nuts (7) **200 TO 250** inch-pounds. Torque nuts (1) **200 TO 250** inch-pounds.

(4) Install lateral cyclic and collective power cylinder assemblies (paragraph 7-66).

b. Install forward and aft cyclic controls power cylinder support (3, figure 11-38) as follows:

(1) Attach power cylinder support (3) to lift beam with four bolts (1), washers (2 and 4), and nuts (5). Place one washer (2) under bolt head with countersunk side against head, and one washer (4) under nut. Do not tighten.

(2) Attach support to forward carry-through fitting with two bolts (9), washers (7 and 8), and nuts (6). Place one washer (8) under bolt head with countersunk side against head, and one washer (7) under nut (6).

(3) Torque nuts (5) **120 TO 145** inch-pounds. Torque nuts (6) **200 TO 250** inch-pounds.

(4) Install System No. 2 hydraulic pump (paragraph 7-23).

(5) Install fore-and-aft cyclic power cylinder assembly (paragraph 7-66).



## CHAPTER 12

### UTILITY SYSTEMS

---

#### SECTION I. FIRE DETECTION SYSTEM

#### 12-1. FIRE DETECTION SYSTEM - ENGINE.

#### 12-2. DESCRIPTION - ENGINE FIRE DETECTION SYSTEM .

The fire detection system consists of a control unit (10, figure 12-1), a FIRE indicator light (2), a fire detector test switch (9), and a heat sensing element (6). The FIRE light will illuminate when the engine compartment temperature reaches approximately 480 degrees F (249 degrees C). The heat sensing element exhibits high electrical resistance at normal ambient temperature, but the resistance drops

rapidly when heated causing an internal relay of the control unit to activate and illuminate the FIRE light. The system is powered by the 28 Vdc essential bus and protected by the FIRE DET<sup>P</sup>, FIRE DETR<sup>E</sup> <sup>M</sup> circuit breaker (8). The FIRE DET TEST switch provides a means of testing the fire detection system. Pressing the FIRE DET TEST switch to TEST places a low resistance across the heat sensing element, simulating a fire condition, thus causing the FIRE light to illuminate.

#### 12-3. TROUBLESHOOTING – ENGINE FIRE DETECTION SYSTEM. Refer to table 12-1.

#### NOTE

Before you use this table, be sure you have performed all normal operational checks. If you have a malfunction which is not listed in this table, notify the next higher level of maintenance.

**Table 12-1. Troubleshooting - Engine Fire Detection System**

---

#### CONDITION

#### TEST OR INSPECTION

#### CORRECTIVE ACTION

FIRE light fails to illuminate when FIRE DET TEST switch is depressed to TEST.

STEP 1. Ensure that voltage is present at pins A & H of control unit.

**If voltage is not present, check wiring (paragraph F-9) and/or replace circuit breaker (paragraph 9-23).**

**If voltage is present, go to step 2.**

STEP 2. Ensure that proper resistance is present at terminal 1 of FIRE DET TEST switch.

**If resistance is not present, check wiring (paragraph F-9) and/or replace 8R2 resistor (paragraph 9-16).**

**If resistance is present, go to step 3.**

**Table 12-1. Troubleshooting - Engine Fire Detection System (Cont)**

---

CONDITION

TEST OR INSPECTION

CORRECTIVE ACTION

STEP 3. Ensure that proper resistance is present at pin 2 of FIRE DET TEST switch.

If resistance is not present, replace switch (paragraph 9-16).

If resistance is present, go to step 4.

STEP 4. Ensure that approximately **245** ohms are present at terminal C of control unit.

If 245 ohms are not present, check wiring (paragraph F-9) and/or replace heat sensing element (paragraphs 12-5 and 12-8).

If 245 ohms are present, go to step 5.

STEP 5. Ensure that 28 Vdc is present at pin 52 of NVG PC (Night vision goggle printed circuit) board.

If voltage is not present, check wiring (paragraph F-9) and/or replace control unit (paragraph 9-16).

If voltage is present, go to step 6.

STEP 6. Ensure that 28 Vdc is present at pin 51 of NVG PC board.

If voltage is not present, replace NVG PC board. If voltage is present, go to step 7.

STEP 7. Ensure that 28 Vdc is present at terminal 1 of FIRE light.

If voltage is not present, check wiring (paragraph F-9). If voltage is present, replace bulb (paragraph 9-16).

---

12-4. TESTING - ENGINE FIRE DETECTION SYSTEM.

- a. Position BAT SWITCH to ON **P**. Position BATTERY switch to RUN or START **E M**
- b. Close Fire Det **P**, FIRE DTR **E M** circuit breaker (8, figure 12-1).
- c. Depress FIRE DET TEST switch (9) to TEST. FIRE light (2) should illuminate. If light does not illuminate, troubleshoot system (paragraph 12-3),

12-5. REMOVAL - ENGINE FIRE DETECTION SYSTEM.

- a. Position BAT **P** BATTERY **E M** switch to OFF.
- b. Disconnect heat sensing element (6, figure 12-1) from connectors (5) at aft firewall. Cover openings with tape (C127).
- c. Remove heat sensing element (6) from 16 quick release clamps. Remove heat sensing element.



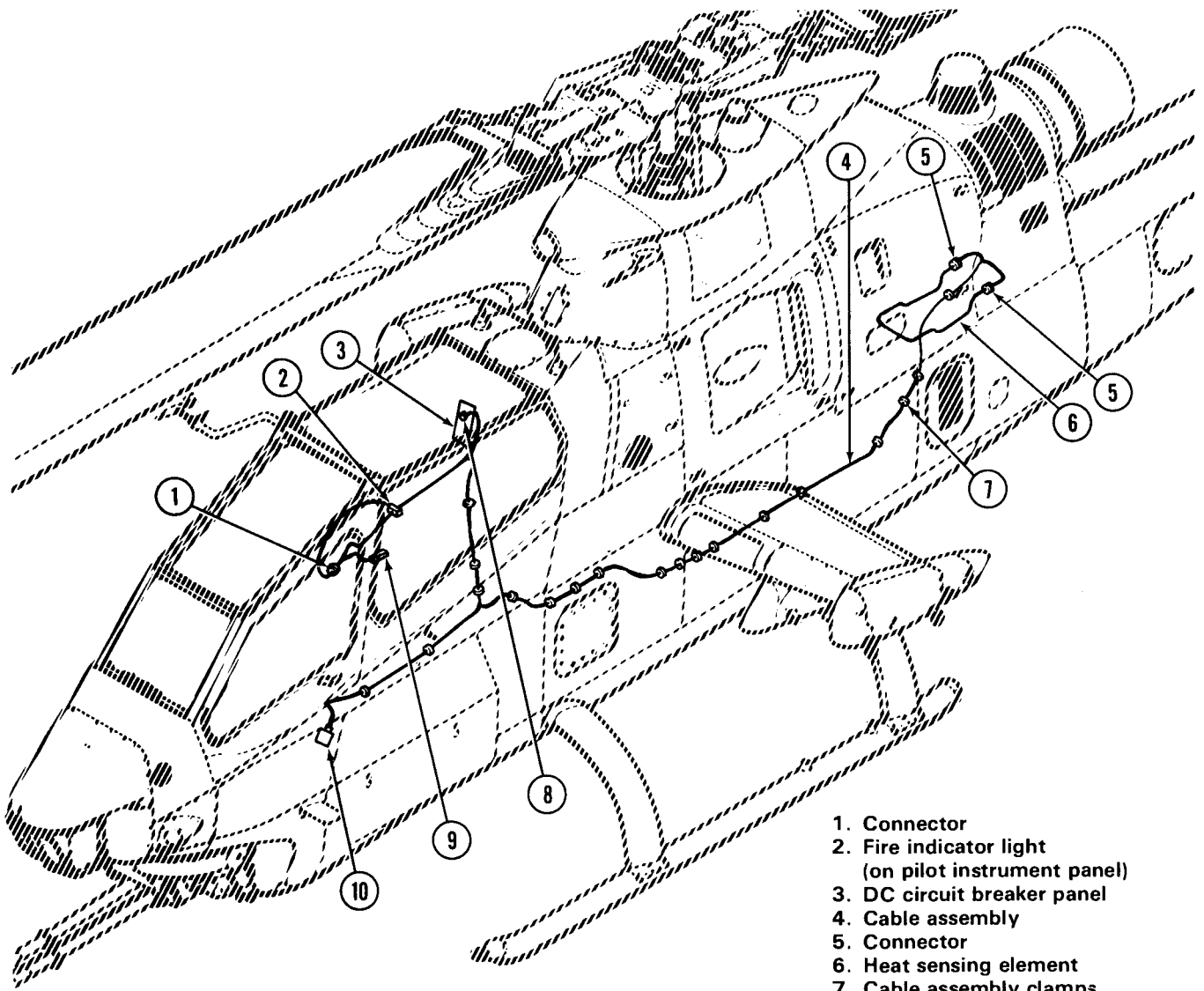

- 1. Connector
- 2. Fire indicator light  
(on pilot instrument panel)
- 3. DC circuit breaker panel
- 4. Cable assembly
- 5. Connector
- 6. Heat sensing element
- 7. Cable assembly clamps
- 8. Circuit breaker
- 9. Fire detector test switch  
(on pilot instrument panel)
- 10. Control unit  
(under gunner left console)

209060-127

Figure 12-1. Engine Fire Detection System

**d.** Remove control unit (10) as follows:

**(1)** Disconnect cable connector from control unit.

**(2)** Disconnect control unit ground cable.

**(3)** Remove four screws, washers, and nuts, securing control unit. Remove control unit.

### **12-6. INSPECTION - ENGINE FIRE DETECTION SYSTEM.**

**a.** Inspect cable assembly (4, figure 12-1) and heat sensing element (6) for damage and wear.

**b.** Inspect cable assembly clamps (7) for cracks and serviceability.

### **12-7. REPAIR OR REPLACEMENT - ENGINE FIRE DETECTION SYSTEM.**

**a.** Replace cable assembly (4, figure 12-1) and heat sensing element (6) if damaged or worn.

**b.** Replace cable assembly clamps (7) if broken, cracked, or unserviceable.

**c.** Replace control unit (10) if case is cracked or damaged.

### **12-8. INSTALLATION - ENGINE FIRE DETECTION SYSTEM.**

**a.** Route heat sensing element (6, figure 12-1) to position.

**b.** Connect heat sensing element (6) to connectors (5).

**c.** Secure heat sensing element (6) with 16 quick release clamps.

**d.** Install control unit (10) with four screws, washers, and nuts.

**e.** Connect cable connector to control unit (10) and secure ground cable to structure.

## **SECTION II. RAIN REMOVAL SYSTEM**

### **12-9. RAIN REMOVAL SYSTEM.**

#### **NOTE**

A rain removal system incorporated in the environmental control system is used in lieu of windshield wipers. Refer to Chapter 13.

## **SECTION III. DEFROSTER SYSTEM**

### **12-10. DEFROSTER.**

#### **NOTE**

A defroster system is incorporated in the environmental control system. Refer to chapter 13.

## SECTION IV. LOW G WARNING SYSTEM

## 12-11. LOW G WARNING SYSTEM (MWO 55-1520-236-50-9 INCORPORATED).

## 12-12. DESCRIPTION - LOW G WARNING SYSTEM.

The low G warning system alerts the pilot that the helicopter is approaching high main rotor flapping angles resulting from low G maneuvers. The warning system consists of a low G warning assembly 8A10 (7, figure 12-2), accelerometer 8A11 (2), low G warning light/switch 8DS25 (1), counter 8M1 (4), relays 8K1 and 8K2 (5), terminal board 8TB15 (6), and circuit breaker 8CB15 (3).

## 12-13. TROUBLESHOOTING - LOW G WARNING SYSTEM. Refer to table 12-2 and figure F-12.2 (MWO 55-1520-236-50-9 Incorporated).

## NOTE

Before using this table, assure that all normal operational checks have been performed. If a malfunction exists and is not listed in this table, notify the next higher level of maintenance.

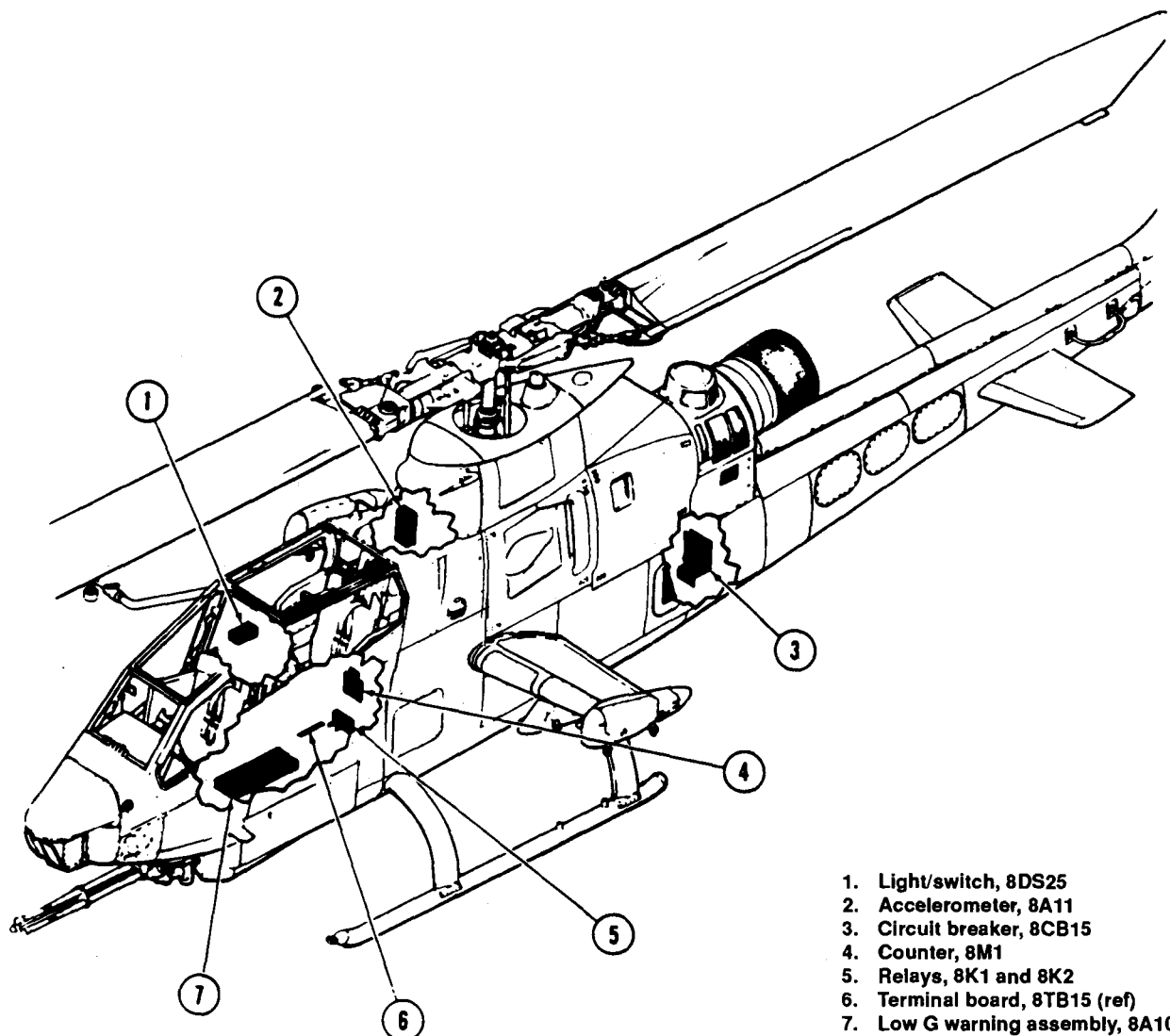

1. Light/switch, 8DS25
2. Accelerometer, 8A11
3. Circuit breaker, 8CB15
4. Counter, 8M1
5. Relays, 8K1 and 8K2
6. Terminal board, 8TB15 (ref)
7. Low G warning assembly, 8A10

Figure 12-2. Low G Warning System

Table 12-2. Troubleshooting - LOW G Warning System

CONDITION

TEST OR INSPECTION

**CORRECTIVE ACTION**

LOW G warning light fails to illuminate and warning audio is absent when 8DS25 is pressed to test.

STEP 1. Ensure that 28 Vdc is present at pin L of 8A10P1 and P27B22.

**If voltage is not present, check wire W219A22 and/or replace circuit breaker 8CB15.**

**If voltage is present, go to step 2.**

STEP 2. Ensure that near zero resistance to ground is present at pin K of 8A10P1 with 8DS25 pressed.

**If resistance is not near zero, check continuity of W216A22 from 8A101-K to 4A1J1-F, W216B22 from 4A1P-F to splice, W216C22 from splice to 8DS25-A-COM, and W217A22 from 8DS25-A-N-O to splice, and W217B22N from splice to ground.**

**If continuity check is good, go to step 3.**

STEP 3. Ensure near zero resistance is present between 8DS25-A-COM and 8DS25-A-N.O. When switch is pressed.

**If resistance is not near zero, replace 8DS25.**

**If resistance check is good, replace 8A10.**

LOW G warning light fails to illuminate, but warning audio is present when 8DS25 is pressed.

STEP 1. Ensure continuity between 8A10P1-E and ground (bulb resistance expected).

**If circuit is open, check wires W216A22, W208A22, W208B22, W210A22, W210B22, W214A22, W214B22, W214C22, W214D22, W215A22N, W215B22N and/or replace 8K1 or 8K2.**

**If circuit is shorted, substitute relays 8K1 and 8K2 and/or check all wires listed above except W215A22N and W215B22N.**

**If continuity check is good, replace 8A10.**

LOW G warning light fails to dim when FLT INSTR LT switch is switched on (press 8DSD25 to illuminate light).

STEP 1, Ensure 28 Vdc on 8XK1-X1 and continuity to ground on 8XK1-X2.

**If circuits check good, replace 8K1.**

LOW G warning light fails to illuminate when FLT INSTR LT switch is on and 8DS25 is pressed.

STEP 1. Remove 8K1 and measure resistance between 8XK1-B1 and B3.

**Table 12-2. Troubleshooting - LOW G Warning System - Continued**

**If circuit reads approximately 161 ohms, replace 8K1.**

**If circuit is open, repair wiring and/or replace 8R20.**

LOW G warning light fails to reduce to NVG level when NVG mode is selected (Press 8DS25 to test light).

STEP 1. Remove 8K2, select NVG mode, check for approximately 28 Vdc at 8XK2-X1 and continuity to ground on 8XK2-X2.

**If voltage is present on X1 and ground is good on X2, replace 8K2.**

**If voltage is missing, troubleshoot NVG system.**

**If ground on 8XK2-X2 is missing, repair circuit.**

LOW G warning light totally extinguishes when NVG mode is selected.

STEP 1. Remove 8K2 and measure resistance between 8XK2-B1 and B3.

**If circuit reads approximately 911 ohms, replace 8K2.**

**If circuit reads open or in error, repair wiring and/or replace 8R21.**

LOW G warning audio not present when warning light is on.

STEP 1. Press LOW G warning light and check for audio in pilot and gunner positions.

**If audio is missing in both positions, replace 8A10.**

**If audio is missing in pilot position only, repair wire W121B22 between 8A10P1-C and 2301TB1-1 and/or refer to TM 11-1520-236-20 for repair of the pilot ICS.**

**If audio is missing in gunner position only, repair wire W122B22 between 8A10P1-D and 2301TB2-1 and/or refer to TM 11-1520-236-20 for repair of the gunner ICS.**

**If any single audio is missing and the preceding corrective actions did not correct the problem, replace 8A10.**

Counter does not register LOW G warning signals.

STEP 1. Disconnect 8A10P1 and measure continuity of wire W220A22 between 8A10P1-M and positive (+) terminal of 8M1. Measure continuity to ground of wire W221A22N between the negative (-) terminal of 8M1 and helicopter ground.

**If wiring check is good, replace 8M1 and/or 8A10 as required.**

LOW G warning system does not generate warning signals.

**Table 12-2. Troubleshooting - LOW G Warning System - Continued**

STEP 1. Disconnect 8A10P1 and 8A11 P1 and check continuity of the following circuits:

From 8A10P1 Pin	Wire No.	To 8A11P1 Pin
C	W191A22	F
A	W190A22 ORN	E
W	W190A22 WHT	c
V	W190A22 BLU	D
H	W194A22 WHT	A
B	W194A22 BLU	B
Shield	W195A22N	Ground
Shield	W196A22N	Ground

**If wiring check is good, replace 8A11 and/or 8A10 as required.**

**12-14. TESTING - LOW G WARNING SYSTEM.**

a. Ensure LOW G circuit breaker 8CB15 (3, figure 12-2) is closed.

b. Position BAT SWITCH to ON **P** Position BATTERY switch to RUN or START **E M**

c. Depress LOW G light/switch (1). Warning light should illuminate and warning audio should be heard in the pilot and gunner headsets. If test results are not achieved, troubleshoot system (paragraph 12-13).

**12-15. REMOVAL - LOW G WARNING SYSTEM.**

a. Position BAT **P**, BATTERY **M** switch to OFF.

b. Open ammunition bay door to access LOW G warning assembly (2, figure 12-3).

c. Remove LOW G warning assembly as follows:

(1) Disconnect connector (1).

(2) Remove screws (4) and washers (3) securing LOW G warning assembly (2). Remove LOW G warning assembly (2).

d. Open right engine air inlet/transmission access door.

e. Remove accelerometer (1, figure 12-4) as follows:

(1) Disconnect connector (2).

(2) Remove screws (3) and washers (4) securing accelerometer (1) to forward bulkhead. Remove accelerometer (1).

f. Gain access to pilot compartment.

g. Remove LOW G warning light/switch (2, figure 12-5) as follows:

(1) Loosen clamp securing LOW G warning lighth/switch (2) in instrument panel (3).

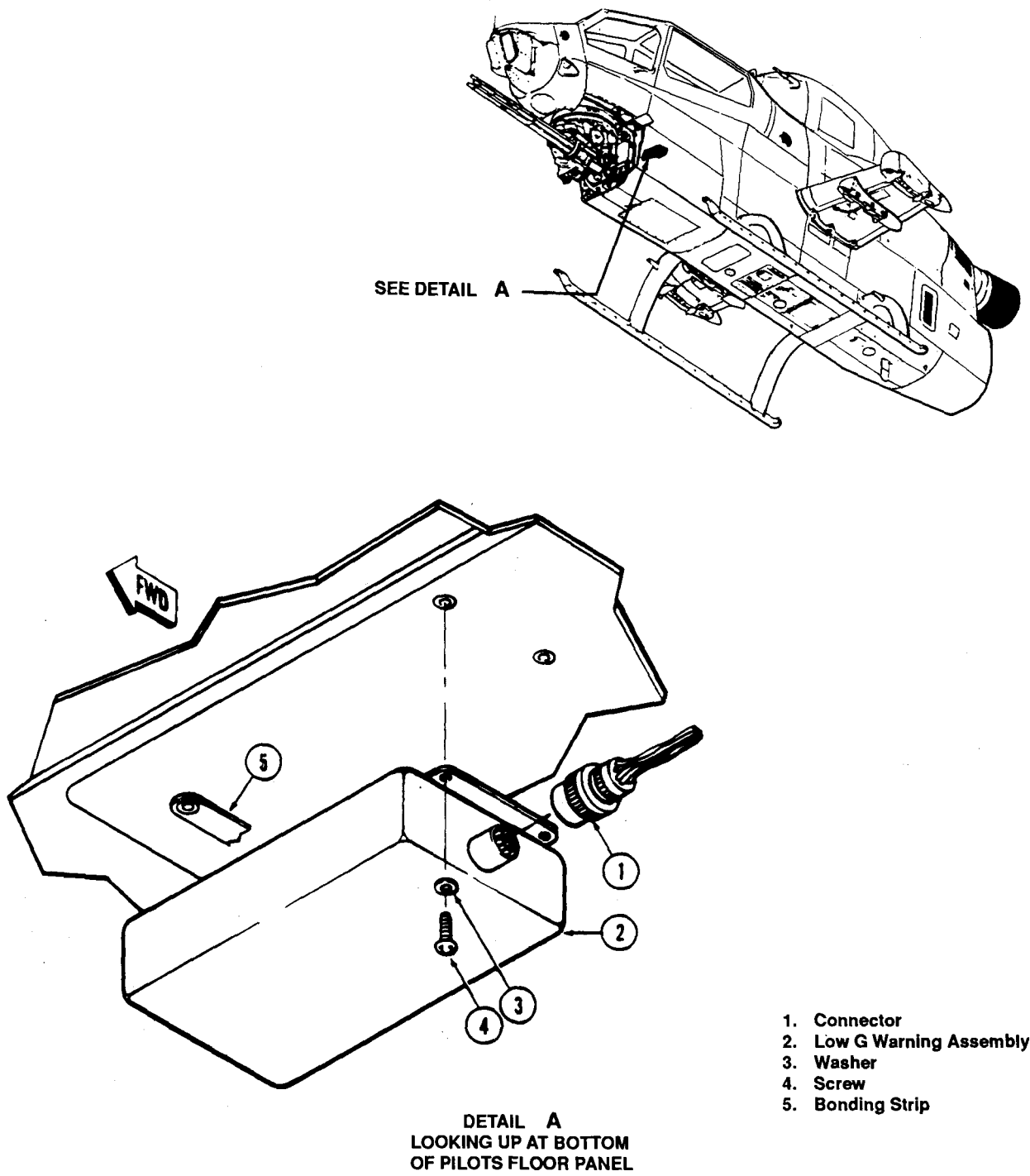

Figure 12-3. Low G Warning Assembly 8A10

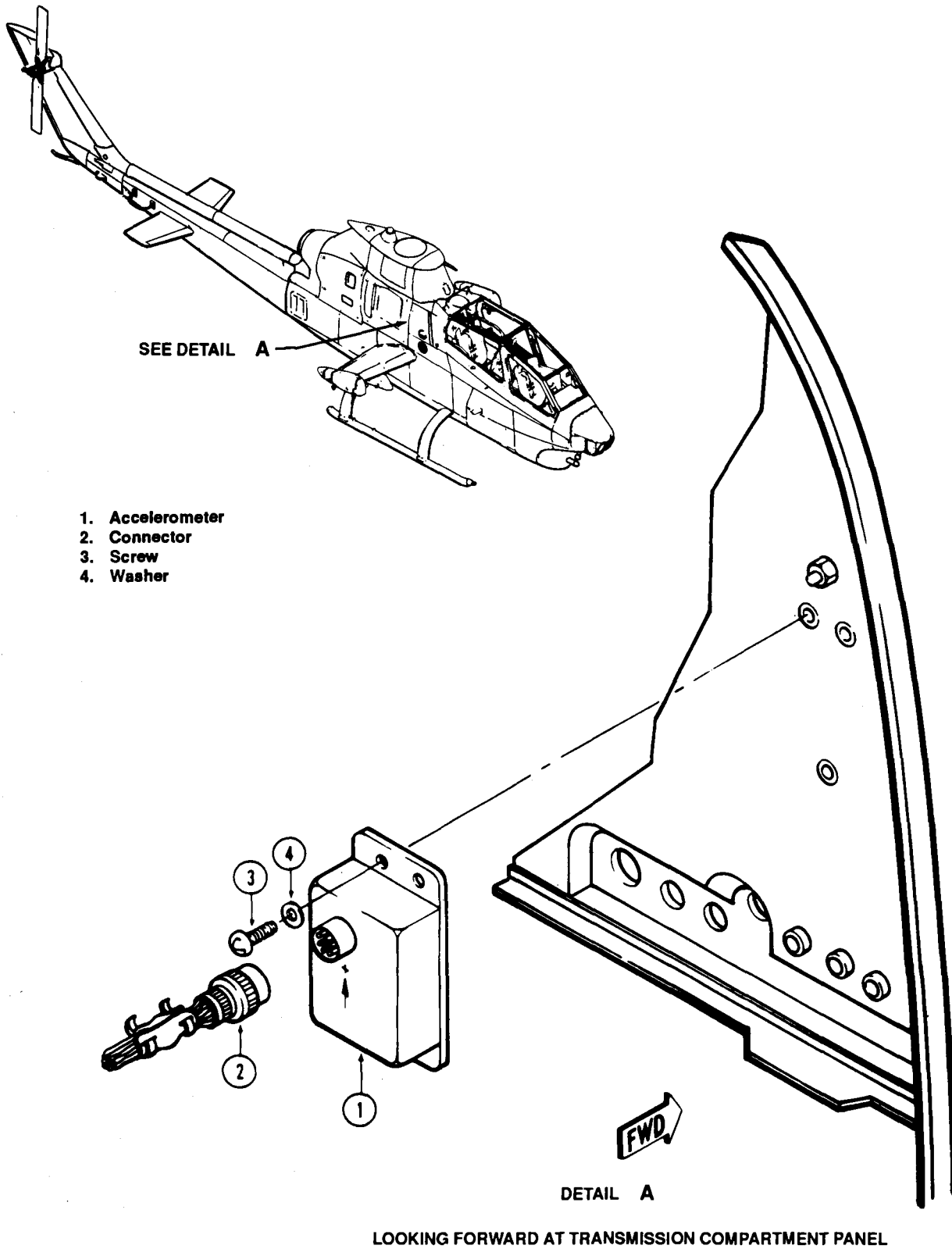

Figure 12-4. Accelerometer 8A11



(2) Extract LOW G warning light/switch (2) from instrument panel (3) between pilot clock (1) and HSI cent (4).

(3) Unsolder wires as required.

h. Remove control panels on pilot left console to access counter (1, figure 12-6).

i. Remove counter (1) as follows:

(1) Remove screws (2) and washers (3) securing counter (1) to bottom of console.

(2) Tag and remove wires attached to counter (1).

(3) Remove counter (1).

### 12-16. INSPECTION - LOW G WARNING SYSTEM.

a. Inspect LOW G warning assembly 8A10, accelerometer 8A11, LOW G warning light/switch 8DS25, and counter 8M1, for dents or damage that would impair normal operation of the units.

b. Inspect connectors for bent, recessed or corroded pins.

c. Inspect cable assembly, terminal board, and relays for damage and serviceability.

### 12-17. REPAIR OR REPLACEMENT - LOW G WARNING SYSTEM.

a. Repair or replace connectors, wiring and terminal boards that fail to meet minimum serviceability standards.

b. Replace LOW G warning assembly, accelerometer, LOW G warning light/switch, and counter if inspection requirements are not satisfied.

### 12-18. INSTALLATION - LOW G WARNING SYSTEM.

a. Install LOW G warning assembly 8A10 as follows:

(1) Open ammunition bay door.

### NOTE

**Ensure bonding strip (5) is positioned between airframe and LOW G warning assembly (2) in accordance with TM 55-1500-323-23.**

(2) Position LOW G warning assembly (2, figure 12-3) on the bottom of the pilot floor panel under the left heel rest.

(3) Install bonding strip (5), washers (3) and screws (4).

(4) Connect connector (1).

b. Install accelerometer 8A11 as follows:

(1) Open right engine air inlet/transmission access door.

(2) Position accelerometer (1, figure 12-4) on forward transmission compartment panel.

(3) Install screws (3) and washers (4).

(4) Connect connector (2).

c. Install LOW G warning light/switch 8DS25 as follows:

(1) Pull wires through clamp and instrument panel hole.

(2) Connect wires to LOW G warning light/switch (2, figure 12-5).

(3) Install LOW G warning light/switch (2) in instrument panel (3) between pilot clock (1) and HSI cent (4).

(4) Secure clamp.

d. Install counter 8M1 as follows:

(1) Position counter (1, figure 12-6) in pilot left console (4).

(2) Install screws (2) and washers (3).

(3) Observe polarity and install wires on counter (1).

(4) Replace panels removed for access.

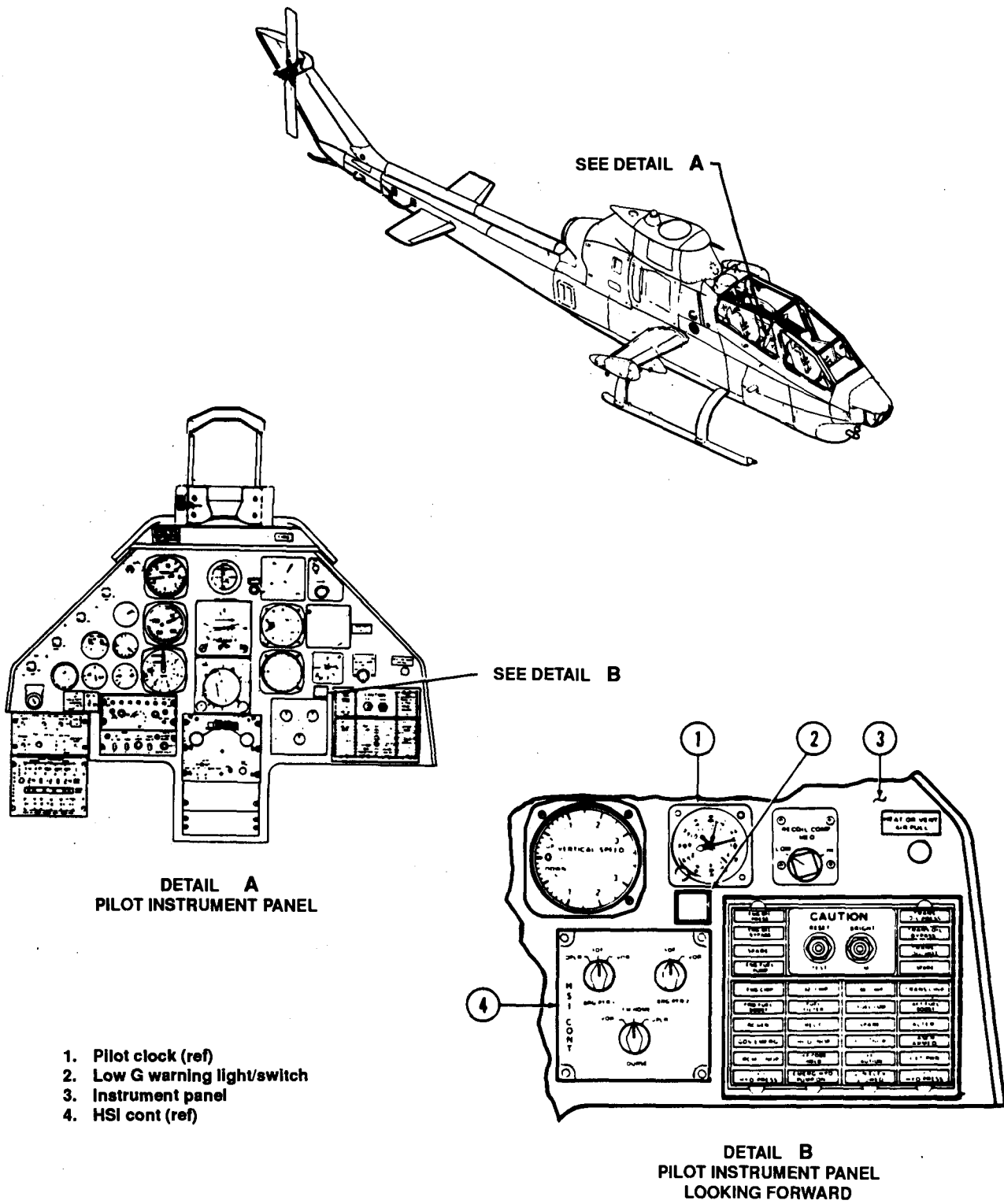

Figure 12-5. Low G Warning Light/Switch 8DS25

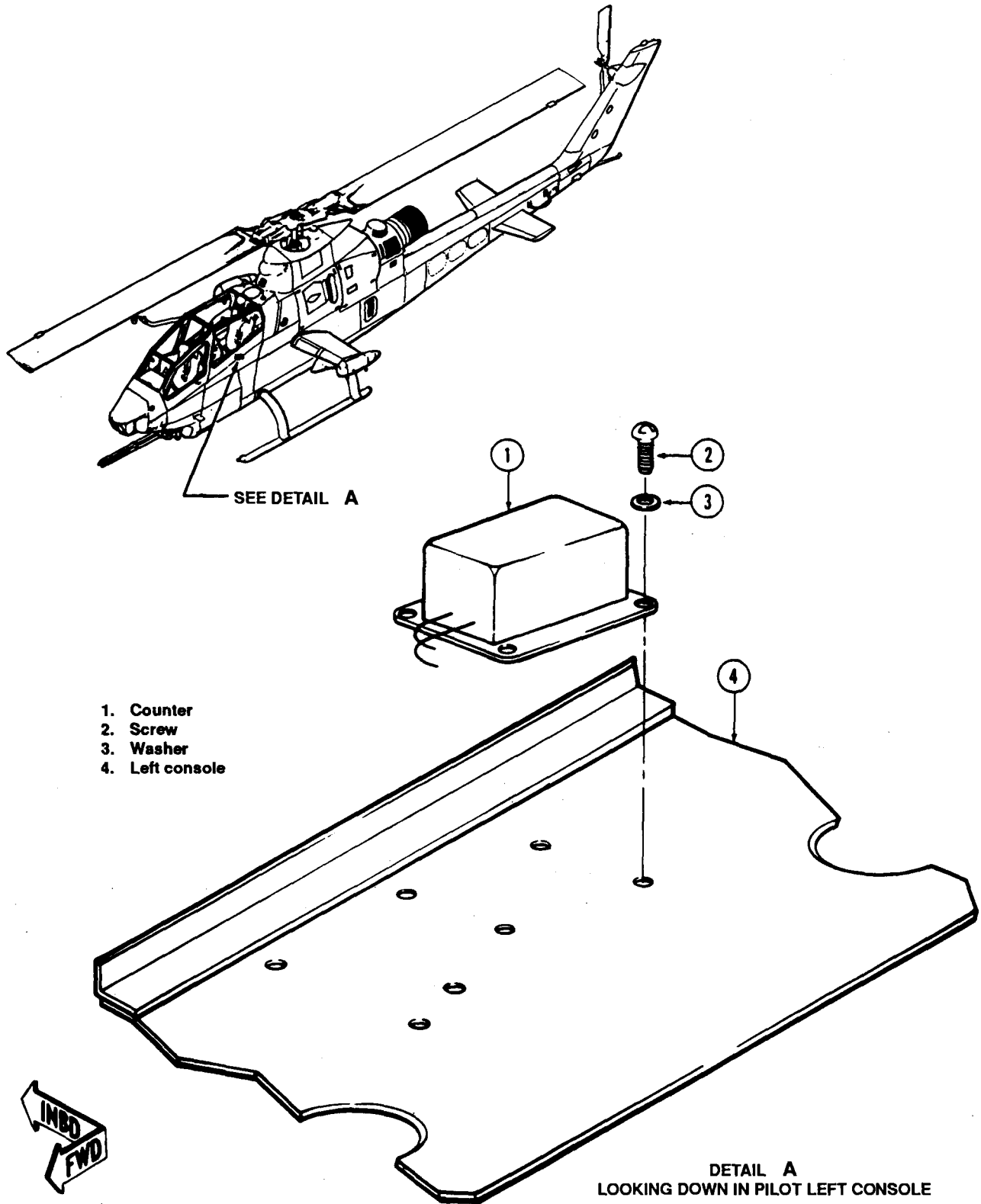

Figure 12-6. Counter 8M1



## CHAPTER 13

### ENVIRONMENTAL CONTROL SYSTEM

---

#### SECTION I. HEATING SYSTEM

##### 13-1. ENVIRONMENTAL CONTROL SYSTEM.

##### 13-2. DESCRIPTION - ENVIRONMENTAL CONTROL SYSTEM.

The environmental control system (ECS) (figure 13-1) provides ventilating air at ambient temperature, or at controlled temperatures, to air distribution ducts and outlets in pilot and gunner compartments. Air is drawn in through a screen on the pylon fairing and delivered to the distribution ducts by a transmission-driven blower operating continuously when the engine is running. Heating and cooling at controlled settings is provided by an environmental control unit (ECU) using bleed air from the engine compressor (figure 13-2). The ECU will provide comfort in ambient air temperatures from -65 degrees F (-54 degrees C) to 125 degrees F (52 degrees C). A rain removal subsystem also uses engine bleed air to clear the windshield of moisture or ice.

##### 13-3. MODES OF OPERATION - ENVIRONMENTAL CONTROL SYSTEM.

a. Airflow to crew compartments is controlled by a HEAT OR VENT AIR PULL control knob on the pilot instrument panel. Each crew seat also has a manual valve controlling airflow through seat cushions. The gunner instrument panel has two butterfly valve outlets. Defog and ventilation outlets on the pilot pedestal have manual control handles.

b. Cool air is provided by the environmental control unit when the HTR/OFF/RAIN RMV switch is at HTR and the ECS COOL/WARM selector is at a COOL setting (figure 13-1). Air for the ECU is bled from the engine compressor through a venturi which restricts the flow. Bleed air pressure is reduced to 35 psi at the pressure regulator and shutoff valve. In the ECU, bleed air is cooled almost to ram air temperature in the heat exchanger, and further cooling is accomplished in the reheater-condenser by recirculating cold turbine discharge air. The bleed air is then expanded through the turbine to complete the cooling cycle. Air flows from the ECU past a control-sensor which is manually set by the temperature selector and regulates output air temperature.

c. Heated air is provided by the ECU when the temperature selector is turned to a WARM setting while the ECS switch is at HTR. Interconnections to the control/sensor, temperature control valve, and vent air control valve regulate output air temperature to the air distribution ducts. A thermal probe (overheat) switch in the duct protects against excessive heat in event of malfunction and would cause the ECU to cycle off and on until trouble is corrected.

##### 13-4. TROUBLESHOOTING - ENVIRONMENTAL CONTROL SYSTEM.

Accomplish troubleshooting of the environmental control system according to table 13-1.

**NOTE**

**Before using this table, ensure all normal operational checks have been performed. If a malfunction occurs which is not listed in this table, notify the next higher level of maintenance.**

**Table 13-1. Troubleshooting ECU**

---

**CONDITION**

TEST OR INSPECTION

**CORRECTIVE ACTION**

1. No airflow from outlets with HEAT OR VENT AIR PULL control full out.

STEP 1. Check position of flapper valve lever on air distribution valve.

**Adjust control cable connection to obtain valve opening.**

STEP 2. Place ECS switch to OFF. Check for airflow.

**If no airflow and shaft driven blower is operating, replace vent air control valve (paragraph 13-66).**

STEP 3. Place ECS switch to HTR. If no airflow, check pressure regulator and shutoff valve for valve stroked open and escaping air from relief valve. If no such signs, disconnect electrical connector from valve, check for 28 Vdc at pin 3 and for ground at pin 6.

**If no power or ground, check and repair wiring circuit.**

**If power and ground are correct, replace valve (paragraphs 13-39 and 13-44).**

2. Airflow from outlets does not become cool when ECS switch is positioned at HTR and temperature selector is positioned COOL.

STEP 1. Disconnect electrical connector from control/sensor. Connect ohmmeter (set at highest resistance) to pins F and G of electrical plug. Rotate temperature selector, observing change in resistance. If meter shows no change, replace temperature selector. Reconnect control/sensor.

STEP 2. Disconnect regulated supply air line from magnetic actuator (figure 13-4) on temperature control valve of ECU.

**If valve closes (goes to cold condition), replace magnetic actuator (paragraph 13-29).**

**If magnetic actuator is operative and valve remains open, replace valve (paragraph 13-22).**

3. Airflow does not become warmer when ECS switch is at HTR and temperature selector turned to WARM.

STEP 1. If all preceding checks have been made, replace control/sensor (paragraph 13-15).

STEP 2. If all preceding checks have been made and all components found operative, replace environmental control unit (paragraph 13-8).

---

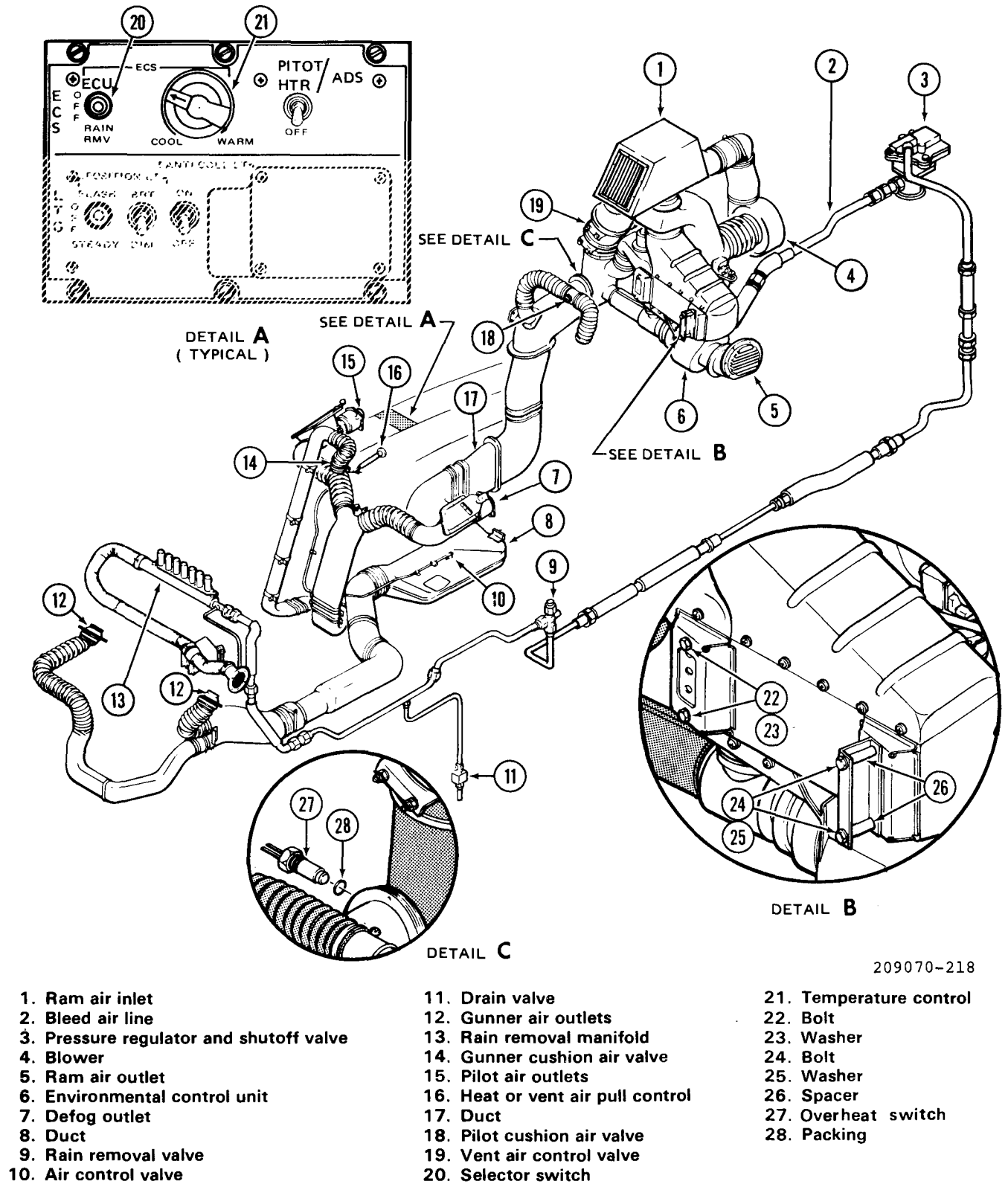

Figure 13-1. Environmental Control System

### 13-5. ENVIRONMENTAL CONTROL UNIT.

#### 13-6. DESCRIPTION - ENVIRONMENTAL CONTROL UNIT.

The environmental control unit (ECU) is the heating and cooling unit for the pilot and gunner, The environmental control system (ECS) is basically composed of a heat exchanger, a reheater-condenser, an expansion turbine, and a jet pump (figure 13-2).

#### 13-7. INSPECTION - ENVIRONMENTAL CONTROL UNIT.

- a. Refer to table 13-1 for functional check.
- b. ECU for visible damage or evidence of leakage.
- c. ECU for security of attachment.
- d. Check to see if interference exists between turbine housing of the ECU and hydraulic compartment floor. Clearance minimum is **0.06** inch. When minimum is exceeded request assistance from next higher maintenance level.

#### 13-8. REPAIR OR REPLACEMENT - ENVIRONMENTAL CONTROL UNIT.

- a. Replace ECU if ECU fails to meet inspection requirements.
- b. Replace if damaged or leakage is evident.
- c. Tighten hardware if not securely attached.

#### 13-9. REMOVAL - ENVIRONMENTAL CONTROL UNIT.

- a. Open hydraulic compartment doors on left and right side.
- b. Disconnect ducts and tubes (1, 5, 10, 12, and 18, figure 13-2) to ECU.
- c. Disconnect electrical plugs from control/sensor (9) and magnetic actuator (2).
- d. Remove bolts (22 and 24, figure 13-1), washers (23 and 25), and spacers (26) attaching ECU to bulkhead in cockpit behind pilot headrest and remove ECU.

### 13-10. INSTALLATION - ENVIRONMENTAL CONTROL UNIT.

- a. Position ECU in hydraulic compartment and align ducts.
- b. Secure ECU to bulkhead with bolts (22 and 24, figure 13-1), washers (23 and 25) and spacers (26). Do not tighten mounting bolts.
- c. Connect ducts and tubes (1, 5, 10, 12, and 18, figure 13-2) to ECU.
- d. Connect electrical plugs to control/sensor (9) and magnetic actuator (2).
- e. Tighten mounting bolts.

#### NOTE

**Ensure minimum clearance between ECU and hydraulic compartment floor is 0.06 inches. Where clearance cannot be obtained, request assistance from next higher maintenance level.**

- f. Connect the fitting connecting bleed air duct (1) to ECU. Torque fitting to **17** foot-pounds and lockwire.

### 13-11. TEMPERATURE CONTROL/SENSOR.

#### 13-12. DESCRIPTION - TEMPERATURE CONTROL/SENSOR.

The temperature control/sensor (9, figure 13-2) is manually set by positioning the rheostat on the pilot ECS control panel, marked COOL WARM. It regulates the output temperature.

#### 13-13. INSPECTION - TEMPERATURE CONTROL/SENSOR.

Visually inspect for cracks, dents, and external damage.

#### 13-14. REMOVAL - TEMPERATURE CONTROL/SENSOR

- a. Disconnect electrical wiring from control/sensor (9, figure 13-2).
- b. Remove screws (20) and washers (21). Then remove control/sensor (9) and gasket (22) from duct (10).



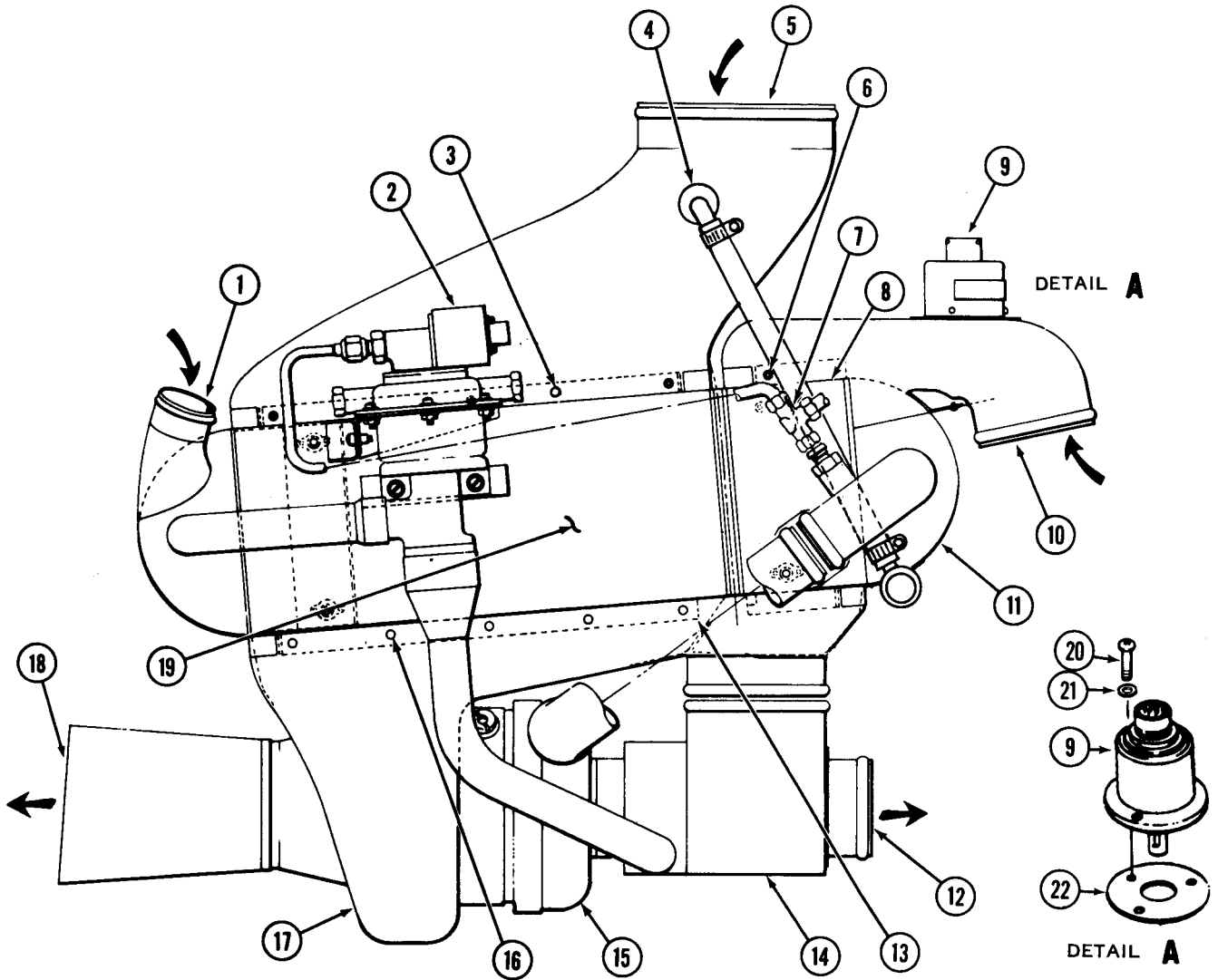

- |   |                                  |
|---|----------------------------------|
| *1. Bleed air inlet duct                            | *12. Conditioned air outlet duct |
| *2. Temperature control valve and magnetic actuator | *13. Bracket clamp and screw     |
| *3. Screw and clamp                                 | *14. Jet pump                    |
| *4. Water injector                                  | *15. Cooling turbine             |
| *5. Ram air inlet duct                              | *16. Screw                       |
| *6. Screw and clamp                                 | *17. Fan                         |
| *7. Tee   | *18. Ram air outlet              |
| *8. Reheater condenser                              | *19. Heat exchanger              |
| *9. Temperature control/sensor                      | *20. Screw                       |
| *10. Recirculated air inlet duct                    | *21. Washer                      |
| *11. Water separator                                | *22. Gasket                      |

\*Disconnect points for ECU removal

209704-1D

Figure 13-2. Environmental Control Unit

**13-15. REPAIR OR REPLACEMENT - TEMPERATURE CONTROL/SENSOR. (AVIM)**

Replace temperature control/sensor if it does not meet inspection requirements.

**13-16. INSTALLATION - TEMPERATURE CONTROL/SENSOR.**

a. Position temperature control/sensor (9, figure 13-2) and gasket (22) on duct (10). Install control/sensor (9), using washers (21) and screws (20).

b. Connect electrical plug to control/sensor (9).

**13-17. TEMPERATURE CONTROL VALVE - ECU.**

**13-18. DESCRIPTION - TEMPERATURE CONTROL VALVE.**

Output air from the ECU is supplied to the magnetic actuator on the temperature control valve. This enables the magnetic actuator to control the temperature control valve and allow the correct amount of hot bleed air to bypass the turbine. The hot bleed air is mixed with conditioned air to maintain the desired temperature in the cabin.

**Premaintenance Requirements for Temperature Control Valve**

Conditions	Requirements
Model	AH-1S
Part No. or Serial No.	All
Special Tools	None
Test Equipment	(T7)
Support Equipment	(S12) (S15)
Minimum Personnel Required	One
Consumable Materials	(C112) (C26) (123) (C79) (C80) (C17)
Special Environmental Conditions	None

**13-19. INSPECTION - TEMPERATURE CONTROL VALVE.**

a. All threads on parts for damage, crossing, cracks, or breakage.

b. Check all valve parts for excessive wear or damage.

**13-20. TESTING - TEMPERATURE CONTROL VALVE. (AVIM)**

Refer to figures 13-4 and 13-5.

**NOTE**

**Perform all tests on helicopter if possible. Equipment required for testing the temperature control valve is listed in premaintenance requirements.**

a. Connect a pressure gage (T7) to the test port (4, figure 13-4). Plug opposite port.

b. Connect a controlled pressure of **15 TO 16** psig to the magnetic actuator inlet (1).

c. Connect a pneumatic source of **32 TO 38** psig with maximum flow of **14.5 TO 15.5** lbs per minute to valve air flow inlet (7).

d. Connect a variable source of **28** Vdc (S12) to pins L and M of the magnetic actuator (2). Slowly increase current until the valve starts to open and a flow is observed. The actuation pressure on the gage should read **4 TO 6** psig.

e. Slowly increase current until valve strokes full open. The actuation pressure on the gage should read 14 psig minimum.

f. Remove voltage supply from magnetic actuator (2).

g. Increase inlet pressure. Check for excessive leakage. Check valve seat for damage or obstruction causing excessive leakage.

**NOTE**

**A small amount of leakage is acceptable.**

h. Decrease inlet pressure to zero and disconnect pressure source from magnetic actuator inlet (1).

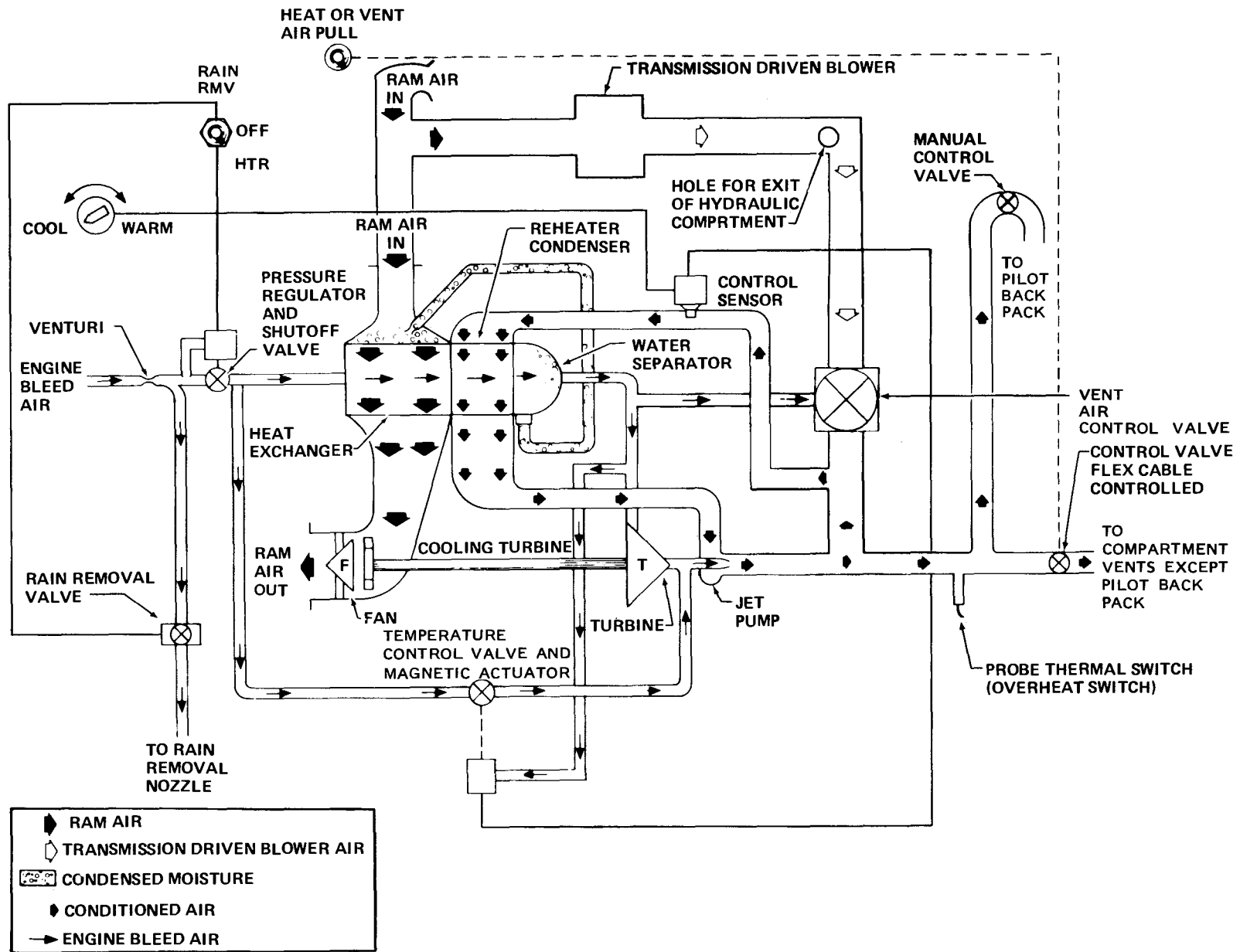

209070-32E

Figure 13-3. Environmental Control System Schematic

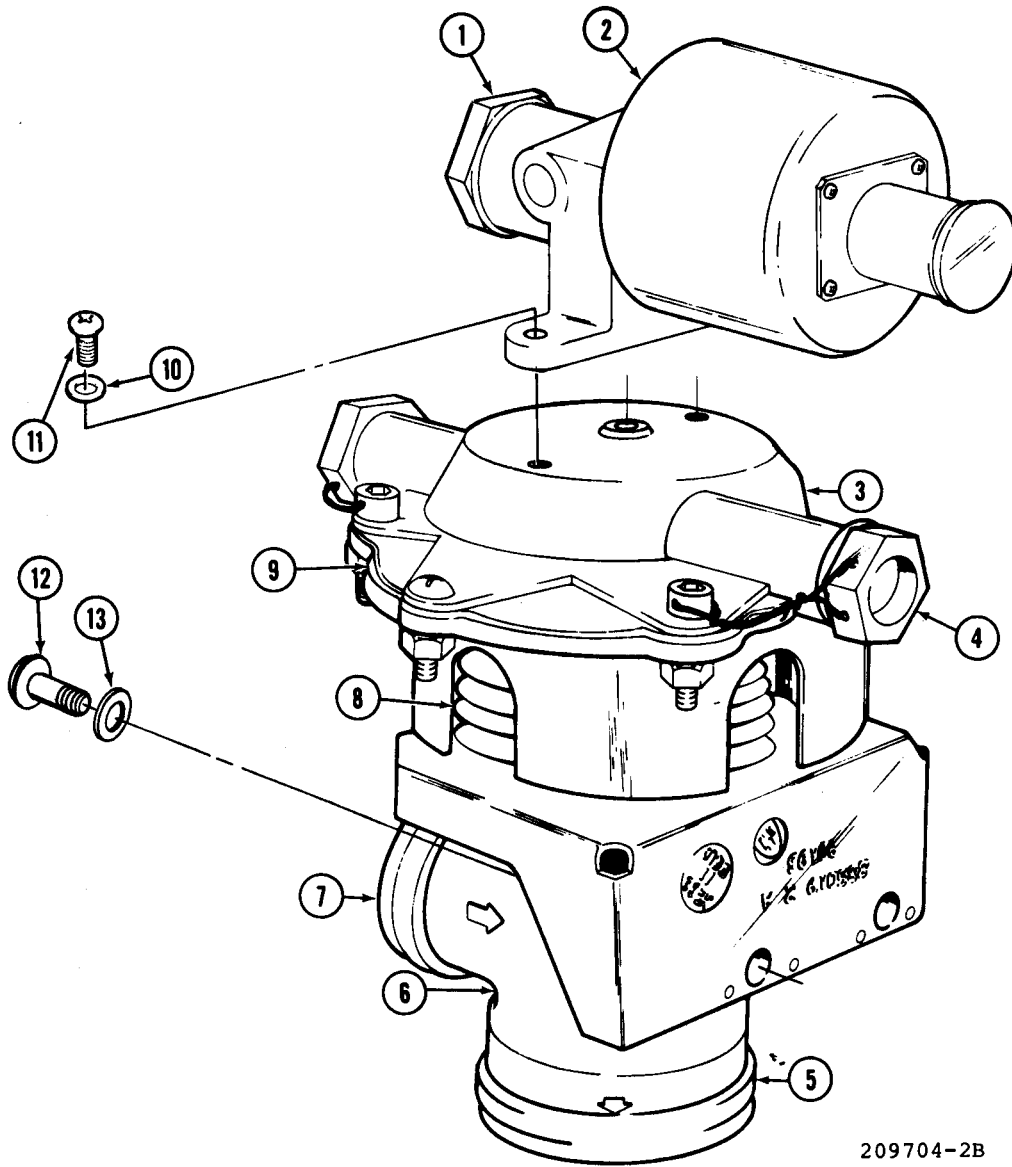

209704-2B

- |                            |                   |
|----------------------------|-------------------|
| 1. Magnetic actuator inlet | 8. Closing spring |
| 2. Magnetic actuator       | 9. Diaphragm      |
| 3. Actuator cover          | 10. Washer        |
| 4. Test port plug          | 11. Screw         |
| 5. Air flow outlet         | 12. Screw         |
| 6. Valve body              | 13. Washer        |
| 7. Air flow inlet          |                   |

Figure 13-4. Temperature Control Valve

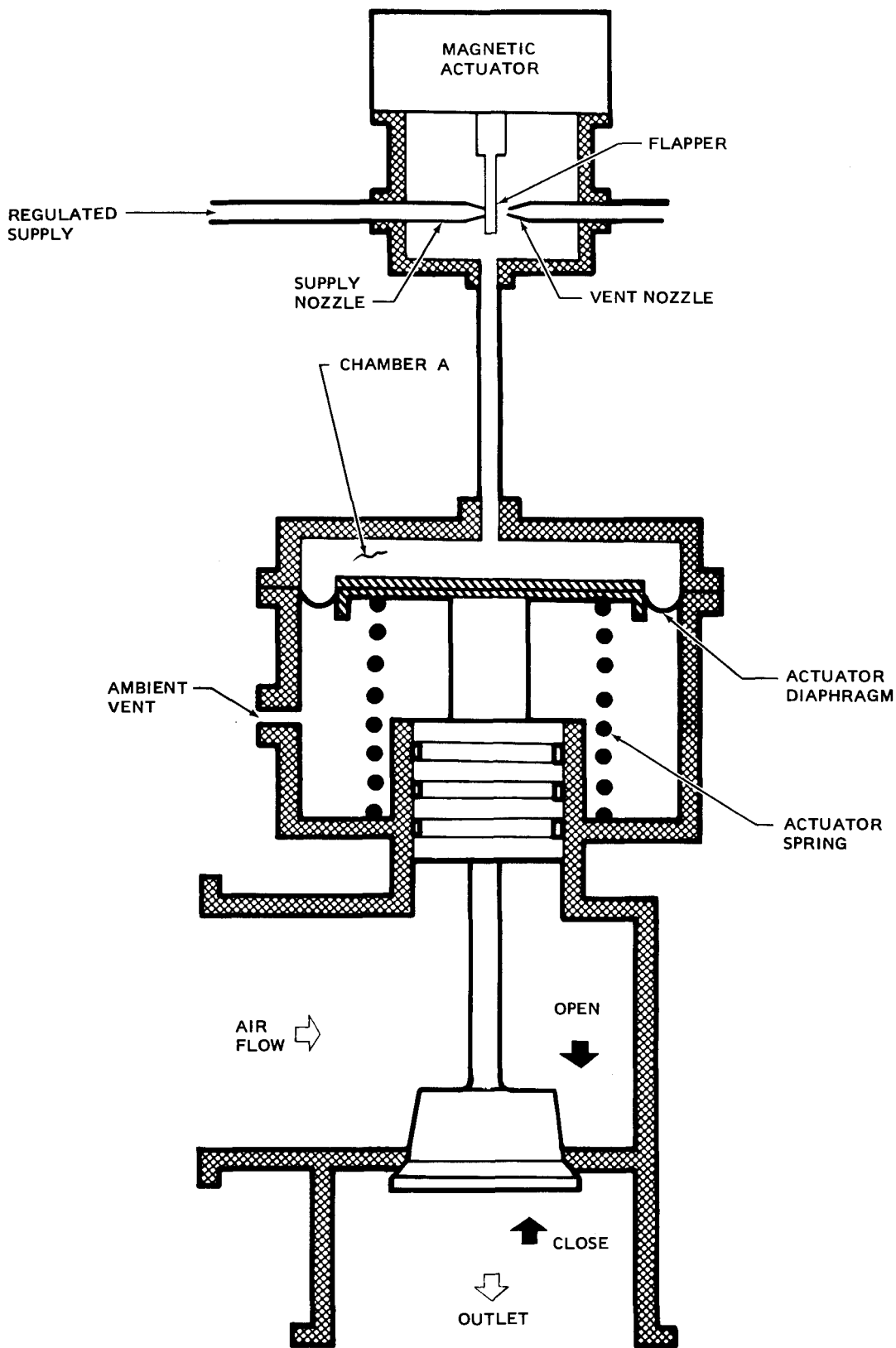

209704-3A

Figure 13-5. Temperature Control Valve Schematic

## TM 55-1520-236-23

- i. Disconnect pressure gage (T7) from test port (4).
- j. Disconnect pneumatic source from airflow inlet (7).
- k. Replace the temperature control valve if it does not operate within limits noted above.

### 13-21. REMOVAL - TEMPERATURE CONTROL VALVE.

- a. Disconnect electrical plug from magnetic actuator (2, figure 1 3-4).
- b. Remove attaching hardware and disconnect duct at inlet air port (7).
- c. Remove attaching hardware and disconnect duct at outlet air flow port (5),
- d. Disconnect tube at regulated pressure supply port (1).
- e. Remove screw (12) and washer (13) attaching valve to bracket. Remove valve from helicopter.

### 13-22. REPAIR OR REPLACEMENT - TEMPERATURE CONTROL VALVE. (AVIM)

- a. Replace valve if damaged, crossed, cracked or broken threads are found.
- b. Replace valve if excessive leakage is detected or seat is damaged,

### 13-23. INSTALLATION - TEMPERATURE CONTROL VALVE.

- a. Position valve and secure to bracket with screws (12, figure 13-4) and washers (13).
- b. Connect tube to magnetic actuator inlet port (1).
- c. Position duct to inlet airport (7) and secure with attaching hardware.
- d. Position duct to outlet air port (5) and secure with attaching hardware.
- e. Connect electrical plug to magnetic actuator (1).

## 13-10

### 13-24. MAGNETIC ACTUATOR.

### 13-25. DESCRIPTION - MAGNETIC ACTUATOR .

The magnetic actuator is attached to the upper part of temperature control valve. As the electrical power to the magnetic actuator is increased, the valve will start to open and allow the passage of air.

### 13-26. INSPECTION - MAGNETIC ACTUATOR.

Inspect for damage and security.

### 13-27. REMOVAL - MAGNETIC ACTUATOR (figure 13-4).

- a. Disconnect electrical connector on magnetic actuator.
- b. Disconnect tube at magnetic actuator inlet (1, figure 13-4).
- c. Remove screws (11) and washers (10).
- d. Remove magnetic actuator from temperature control valve.

### 13-28. CLEANING - MAGNETIC ACTUATOR.

#### **WARNING**

**Cleaning solvent is flammable and toxic. Provide adequate ventilation. Avoid prolonged breathing of solvent vapors and contact with skin or eyes.**

- a. Clean magnetic actuator with a clean lint-free cloth moistened with solvent (C112).
- b. Dry with a clean lint-free cloth.

### 13-29. REPAIR OR REPLACEMENT - MAGNETIC ACTUATOR.

Replace magnetic actuator if it is damaged or fails to meet inspection requirements.

### 13-30. INSTALLATION - MAGNETIC ACTUATOR (FIGURE 13-4).

- a. Position magnetic actuator on temperature control valve and secure with washers (10) and screws (11).
- b. Connect tube at magnetic actuator inlet (1).
- c. Connect electrical connector to magnetic actuator.

### 13-31. ECU COOLING TURBINE.

### 13-32. DESCRIPTION - ECU COOLING TURBINE.

The cooling turbine is an integral part of the ECU. The purpose of the cooling turbine is to take the cool high-pressure bleed air leaving the reheater-condenser and expand it, causing its temperature to be reduced by the extraction of energy from the air. The shaft energy produced in the turbine is transmitted through the common shaft to a fan which, in turn, loads the turbine and induces ram air across the heat exchanger. The cooling turbine consists of a straight bladed radial inflow turbine wheel mounted on a common shaft with an axial flow fan. The rotating assembly is supported on ball bearings and is lubricated by wool-felt wicks leading to the shaft from a cotton-packed oil sump.

### 13-33. INSPECTION - ECU COOLING TURBINE.

- a. Inspect for unusual noises while operating.
- b. Inspect for binding rotating assembly, rough operation, or binding bearings and rubbing of turbine blades in scroll.
- c. Do not perform any maintenance on the ECU cooling turbine except the inspection.

### 13-34. REMOVAL - ECU COOLING TURBINE.

- a. Remove environmental control unit (ECU) (6, figure 13-1) (paragraph 13-9).
- b. Remove cooling turbine.

(1) Remove housing assembly (8, figure 13-6) and nozzle (9) by loosening clamps (5) and (7) and

removing housing assembly (8), with nozzle (9), and hose (6).

(2) If housing assembly (8), nozzle (9), or hose (6) requires replacement, remove retainer (10); cut out adhesive between housing assembly (8), nozzle (9), and hose (6). Separate parts.

(3) Remove packing (11) from cooling turbine (12). Replace packing regardless of condition.

#### **WARNING**

**Cleaning solvent is flammable and toxic. Provide adequate ventilation. Avoid prolonged breathing of solvent vapors and contact with skin or eyes.**

(4) Wash all parts with solvent (C112) and dry parts with compressed air.

(5) If housing assembly (8) and nozzle (9) are separated, cut out adhesive residue on mating surfaces. Inspect housing assembly and nozzle for cracks. Inspect duct of housing assembly for loose cement joints.

(6) Loosen couplings (19) and disconnect valve (23) with couplings and sleeve (20).

(7) Remove screw (17) and washer (16) and duct assembly (18) from cooling turbine (12) and remove packing (15). Replace packing (15) regardless of condition.

(8) Remove bolts (13) washers (14), and cooling turbine (12).

(9) Remove washer (21).

#### **WARNING**

**Cleaning solvent is flammable and toxic. Provide adequate ventilation. Avoid prolonged breathing of solvent vapors and contact with skin or eyes.**

(10) Wipe exterior surfaces of turbine with a clean, lint-free cloth moistened with solvent (C112).

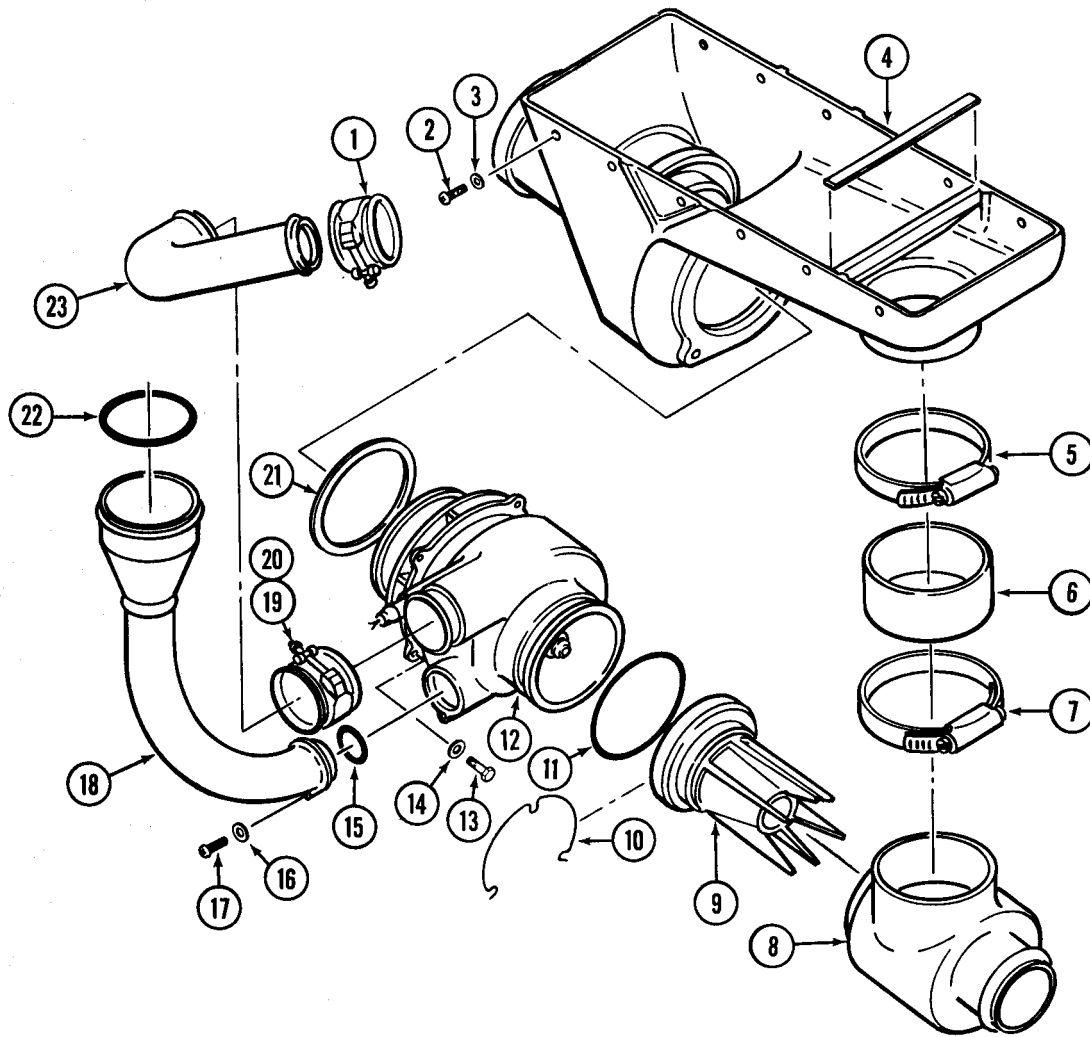

209706-53A

- |                     |              |                   |
|---------------------|--------------|-------------------|
| 1. Coupling         | 9. Nozzle    | 17. Screw         |
| 2. Screw            | 10. Retainer | 18. Duct assembly |
| 3. Washer           | 11. Packing  | 19. Coupling      |
| 4. Duct assembly    | 12. Turbine  | 20. Sleeve        |
| 5. Clamp            | 13. Bolt     | 21. Washer        |
| 6. Hose             | 14. Washer   | 22. Packing       |
| 7. Clamp            | 15. Packing  | 23. Tube          |
| 8. Housing assembly | 16. Washer   |                   |

Figure 13-6. ECU Cooling Turbine



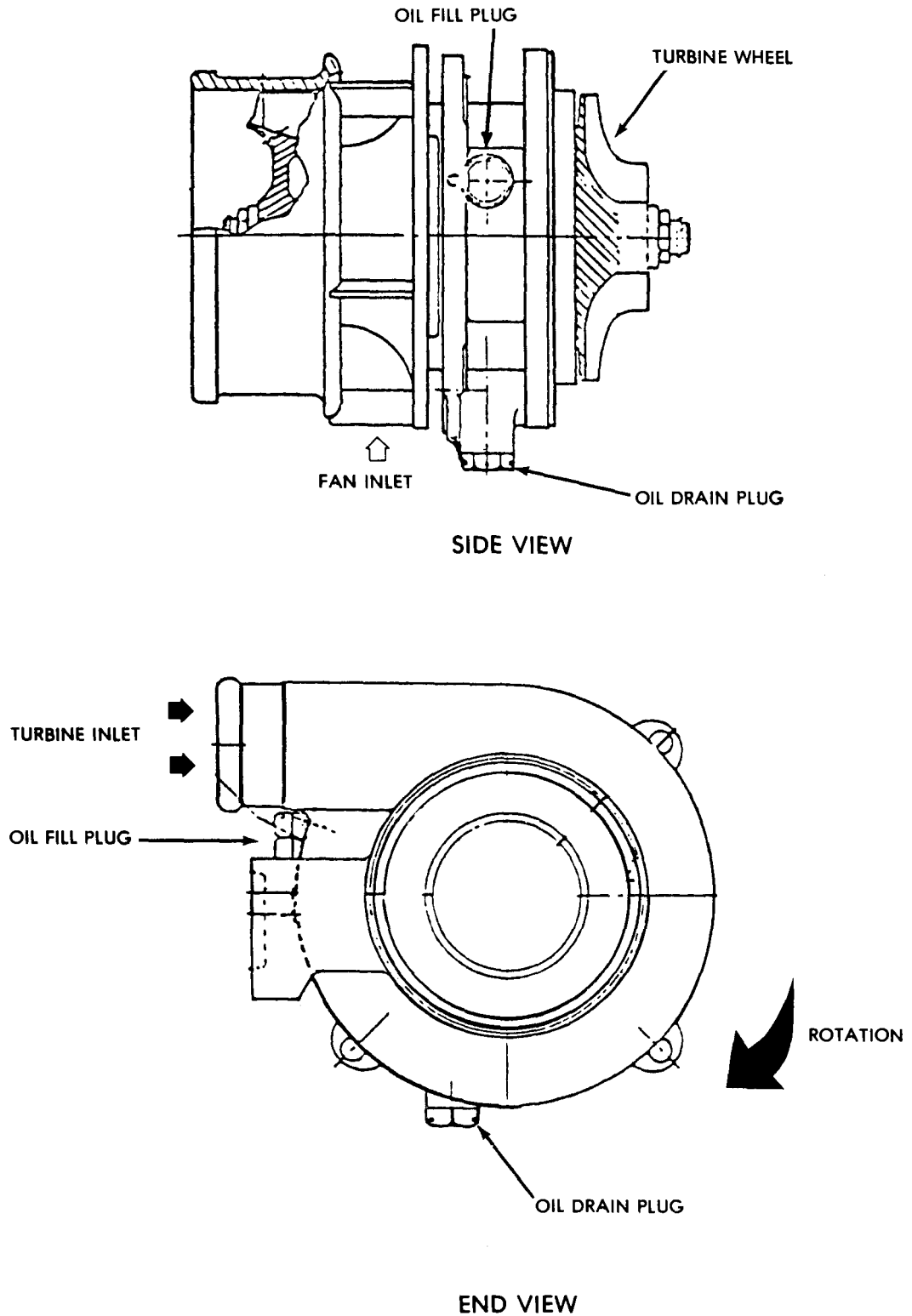

Figure 13-6.1. ECU Cooling Turbine Lubrication

(11) Install moisture and dust seal protective cap over impeller outlet. Also place masking tape (CI 23) over impeller inlet.

(12) Install moisture and dust seal protective cap (P/N FC300) (FSCM 1581) over turbine outlet.

(13) Install protective cap (26) over turbine inlet.

(14) Install protective plug (NAS816-123) in turbine inlet port.

**13.34.1. INSPECTION – HEAT EXCHANGER DUCTS.**

inspect for damage or leaks in ducts. No deterioration, cracks, or loose bonded joints allowed.



**13-34.2. REPAIR OR REPLACEMENT - HEAT EXCHANGER DUCTS.**

Repair minor damage to polycarbonate plastic items as follows:

- a. Stop drill cracks with a No. 30 drill.
- b. Fabricate a patch from material (C86.1). Form the material to nest over the damaged area with a 0.75 inch overlap.
- c. Lightly sand the mating surfaces of the part to be repaired and the patch with 300 grit sandpaper (C102). Wipe clean areas with a clean cloth. Do not use solvents.
- d. Mix adhesive (C17.1) and apply to repair patch mating surface. Place patch on repair and apply 5 to 20 psi pressure during cure cycle of 7 days at 70 to 80°F, or two hours at 160°F.
- e. After cure of adhesive, apply a coat of Ixocote (C72.1).

**13-35. REPAIR OR REPLACEMENT - ECU COOLING TURBINE.**

Replace ECU cooling turbine if it fails to meet inspection requirements.

**13-35.1. LUBRICATION - ECU COOLING TURBINE.**

- a. Remove filler plug (figure 13-6.1).
- b. Add approximately 50cc of lubricating oil (C79 or C80).
- c. Allow two minutes for oil wicks to become saturated.
- d. Remove drain plug. Allow excess oil to drain out.



**Do not over lubricate. Excessive lubrication may cause damage to turbine. Excess oil must be drained before operation. Excess oil drained from turbine must not be reused.**

- e. Insert wires into housing if protruding. Wires are utilized for functional test of turbine.
- f. Install drain plug and filler plug and safety with lockwire (C137).

**13-36. INSTALLATION - ECU COOLING TURBINE.**

**NOTE**

**Refer to paragraph 13-35.1 for lubrication instructions prior to installation.**

a. Install washer (21, figure 13-6) in outlet of duct assembly (4), position turbine (12) against washer (21) and align bolt holes. Install bolts (13) and washers (14).

b. Apply lubricating oil (C79 or C80) on packing (11), and install packing on groove or turbine scroll.

c. Mix adhesive and activator (C17), and apply to joining surfaces of hose (6), housing assembly (8), and nozzle (9); then install hose (6) on housing assembly (8). Insert nozzle (9) into housing assembly (8). Position housing assembly (8) and nozzle (9) on turbine scroll. Install retainer (10). Position hose (6) on duct assembly (4). Install clamps (5 and 7) to secure hose (6) on duct assembly (4) and housing assembly (8). Tighten upper clamp (5) on hose but snug lower clamp (7) lightly to prevent squeezing out adhesive, Check that nozzle (9) is aligned in turbine scroll.

d. Install sleeve (20) over each end of tube (23). Position duct and sleeves in place and install couplings (1 and 19).

e. Install packing (15) in groove of turbine scroll.

f. Insert duct assembly (18) in turbine scroll and install screw (17) and washer (16).

**13-37. PRESSURE REGULATING AND SHUTOFF VALVE.**

**13-38. DESCRIPTION - PRESSURE REGULATING AND SHUTOFF VALVE.**

The pressure regulating and shutoff valve is located in the engine compartment and limits the flow of bleed air to the ECU. It also acts as an ON-OFF valve for the ECS.

**Premaintenance Requirements for Pressure Regulating and Shutoff Valve**

Condition	Requirements
Model	AH-1P/E/F
Part No. or Serial No.	All
Special Tools	None
Test Equipment	(T7)
Support Equipment	(S12) (S15)
Minimum Personnel Required	Two
Consumable Materials	(C112)
Special Environmental Conditions	None

**13-39. REMOVAL - PRESSURE REGULATING AND SHUTOFF VALVE.**

a. Open engine cowling on left side, and disconnect electrical plug from solenoid (2, figure 13-7.)

b. Disconnect supply pressure tube at supply inlet port (1).

c. Disconnect duct at air flow outlet (6).

d. Disconnect tube at air flow inlet (7).

e. Remove screws (10), washers (11), and nuts (12), holding bracket (9) to structure and remove valve (5).

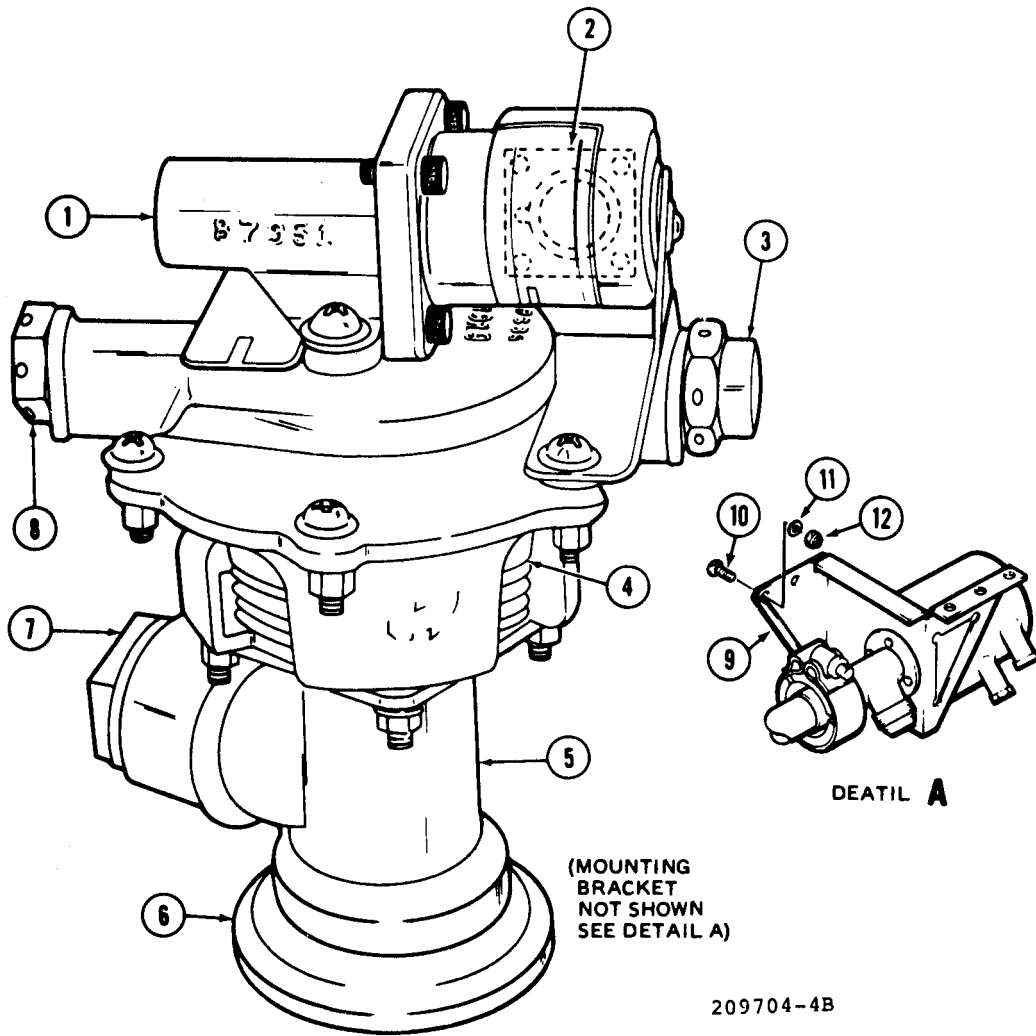

- 1. Supply inlet
- 2. Solenoid
- 3. Relief valve
- 4. Closing spring

- 5. Valve body
- 6. Air flow outlet
- 7. Air flow inlet
- 8. Test port

- 9. Bracket
- 10. Screw
- 11. Washer
- 12. Nut

**Figure 13-7. Pressure Regulator and Shutoff Valve**

**13-40. CLEANING - PRESSURE REGULATING AND SHUTOFF VALVE.****WARNING**

**Cleaning solvent is flammable and toxic. Provide adequate ventilation. Avoid prolonged breathing of solvent vapors and contact with skin or eyes.**

- a. Clean pressure regulator and shutoff valve with solvent (C112).
- b. Wipe dry with a clean lint-free cloth.

**13-41. INSPECTION - PRESSURE REGULATING AND SHUTOFF VALVE.**

- a. Visually inspect all threaded parts for crossed, broken, or cracked threads.
- b. Inspect for excessive wear or damage and leaking.

**13-42. REPAIR OR REPLACEMENT - PRESSURE REGULATING AND SHUTOFF VALVE.**

- a. Replace valve if damaged, cracked, crossed, or broken threads are found.
- b. Replace valve if excessive leakage is detected or seat is damaged. (Refer to troubleshooting chart, table 13-1, for operational check).

**13-43. TESTING - PRESSURE REGULATING AND SHUTOFF VALVE (FIGURES 13-7 and 13-8). (AVIM)****NOTE**

**Perform all tests on helicopter if possible. Equipment required for testing the pressure regulating and shutoff valve is listed in the premaintenance requirements.**

- a. Connect regulated air to supply inlet (1, figure 13-7).
- b. Connect pressure gage (T7) to test port (8).

c. Apply **28** Vdc power (S12) to pins 3 and 6 to energize solenoid (2). Confirm that solenoid shifts position by audible click when the power is applied.

d. Increase inlet pressure to **20** psig.

e. If valve fails to stroke open, replace solenoid (2).

f. Actuator head pressure should be between **7** and **8** psig. Relief valve (3) should relieve at **7 TO 8** psig. If pressure exceeds **8** psig or no valve action is seen, replace relief valve.

g. Set downstream flow control gate to flow maximum of **14.5 TO 15.5** lbs per minute at **35** psig during test.

h. Reduce inlet pressure to **40** psig. Valve should regulate to **32 TO 38** psig. If valve fails to regulate, replace valve.

i. De-energize solenoid (2). Valve should close.

j. Energize solenoid (2). Valve should open and regulate **32 TO 38** psig.

k. De-energize solenoid (2) and increase inlet pressure. Check for leakage. Check valve seat for damage or obstruction causing excessive leakage.

**NOTE**

**Some leakage is acceptable.**

l. Decrease inlet pressure to zero and disconnect from valve.

m. Disconnect pressure gage.

n. Disconnect electrical power source.

o. Replace pressure regulating and shutoff valve if it fails to meet the inspection requirements.

**13-44. INSTALLATION - PRESSURE REGULATING AND SHUTOFF VALVE.**

a. Secure valve to structure with bracket (9, figure 13-7), using screws (10), washers (11), and nuts (12).

b. Position tube to airflow outlet (6) and secure with attaching hardware.

c. Position duct to supply inlet (1) and secure with attaching hardware.

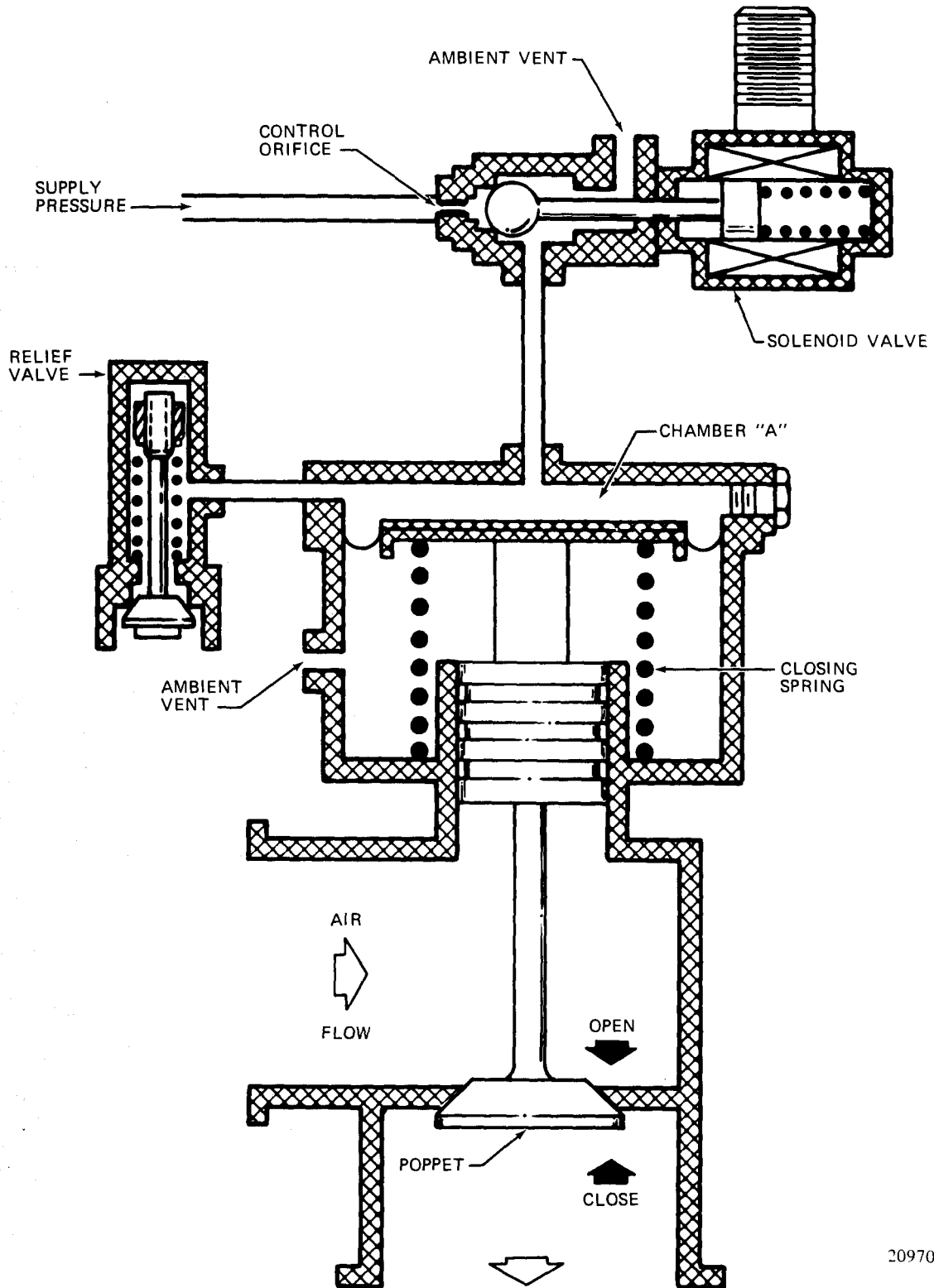

209704-5

Figure 13-8. Pressure Regulator and Shutoff Valve Schematic

- d. Connect electrical plug to solenoid on valve (2).
- e. Install engine cowling on left side of helicopter.

**13-44.1. AIR DISTRIBUTION PRESSURE REGULATOR VALVE SOLENOID FILTER.**

**13-44.2. DESCRIPTION - AIR DISTRIBUTION PRESSURE REGULATOR VALVE SOLENOID FILTER.**

The solenoid filter is located in the supply pressure port of solenoid valve. The purpose of the filter is to filter supply air to the pressure solenoid.

**13-44.3. REMOVAL - AIR DISTRIBUTION PRESSURE REGULATOR VALVE SOLENOID FILTER.**

Remove the pressure supply line and remove filter assembly from solenoid.

**13-44.4. CLEANING - AIR DISTRIBUTION PRESSURE REGULATOR VALVE SOLENOID FILTER.**

Disassemble filter and clean with solvent (C112). Dry with compressed air.

**13-44.5 INSPECTION - AIR DISTRIBUTION PRESSURE REGULATOR VALVE SOLENOID FILTER.**

Inspect filter for cleanliness and deformation  
Reassemble filter.

**13-44.6. INSTALLATION - AIR DISTRIBUTION PRESSURE REGULATOR VALVE SOLENOID FILTER.**

Install filter assembly into solenoid and connect air supply line.

**13-45. THERMAL PROBE SWITCH.**

**13-46. DESCRIPTION - THERMAL PROBE SWITCH.**

A thermal probe switch is installed in a duct in the outlet side of the ECU to prevent excessively hot air from entering the distribution system. If excessive heat reaches the overheat switch, the switch opens,

actuating the solenoid valve to shut off the flow of bleed air to the ECU.

**13-47. REMOVAL - THERMAL PROBE SWITCH.**

- a. Remove electrical wiring.
- b. Remove thermal switch (27, figure 13-1) and packing (28) from duct.

**13-48. INSPECTION - THERMAL PROBE SWITCH.**

Inspect thermal switch for corrosion and condition.

**13-49. REPAIR OR REPLACEMENT - THERMAL PROBE SWITCH.**

Replace switch if it fails to meet inspection or operational requirements. Switch opens at **225** degrees F  $\pm$  8 degrees F, switch closes at **260** degrees F  $\pm$  6 degrees F.

**13-50. INSTALLATION - THERMAL PROBE SWITCH.**

- a. Place packing (28, figure 13-1) on thermal probe switch (27) and install switch in duct.
- b. Connect electrical wiring.

**13-51. AMBIENT AIR BLOWER.**

**13-52. DESCRIPTION - AMBIENT AIR BLOWER.**

A continuously operated transmission drive blower (4, figure 13-1) is mounted on a pad provided on the forward side of the transmission.

**Premaintenance Requirements for Blower**

Condition	Requirements
Model	AH-1E, F, & P
Part No. or Serial No.	All
Special Tools	None
Test Equipment	None

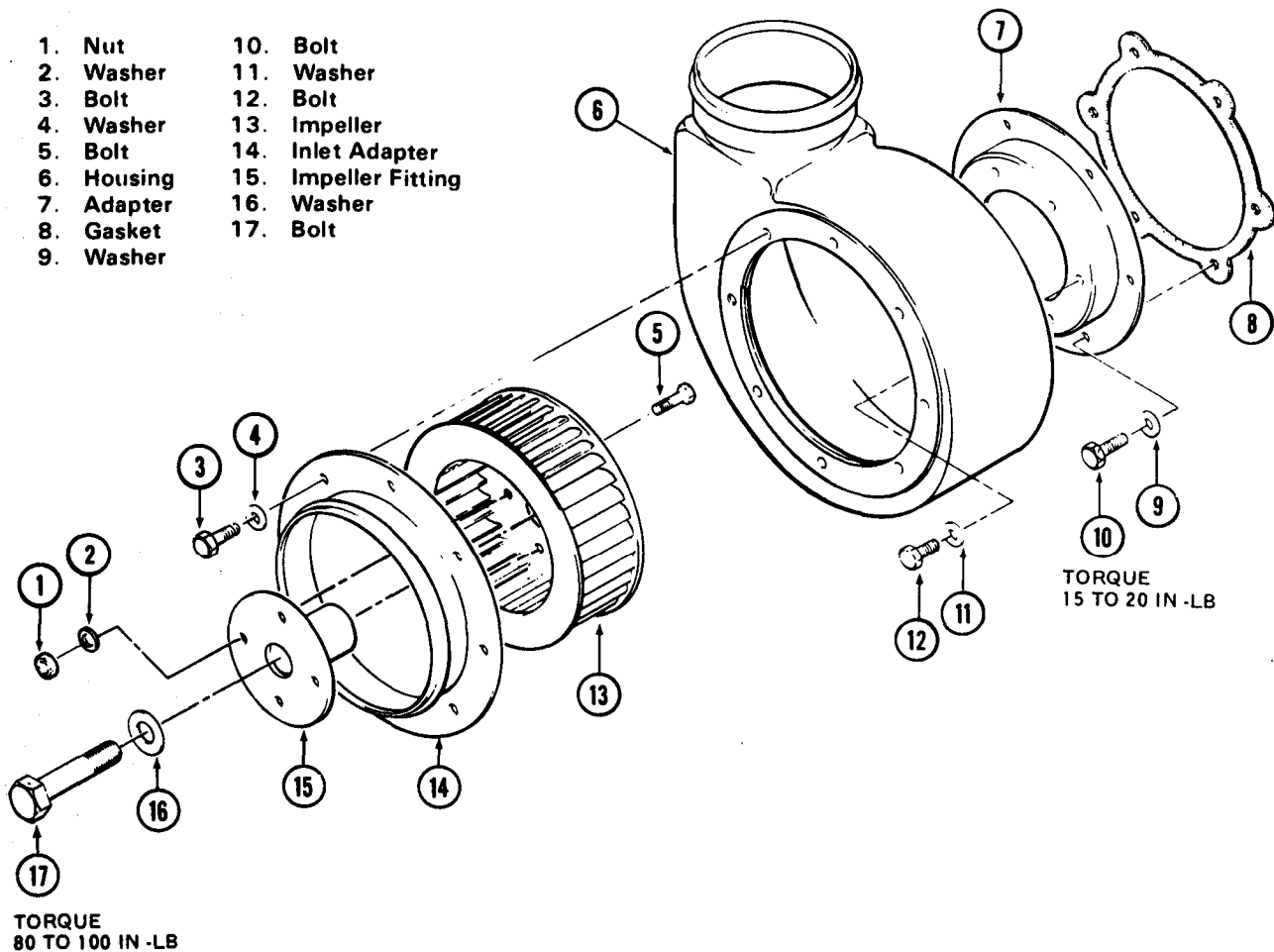

Figure 13-9. Blower Impeller Assembly

Support Equipment None

Minimum Personnel Two  
Required

Consumable Materials (C36) (C88) (C91) (C112)  
(C138)

Special Environmental None  
Conditions

**13-53. REMOVAL - AMBIENT AIR BLOWER.**

a. Open hydraulic compartment door on right side of helicopter and remove right side transmission cowling to gain access to blower area.

b. Remove intake and exhaust ducts by removing clamps and hardware.

c. Remove eight attaching bolts (3, figure 13-9), washers (4), and remove inlet adapter (14).

d. Cut lockwire and remove bolt (17) and washer (16).

e. Separate housing (6) from transmission pad by cutting lockwire and removing bolts (10) and washers (9).

**13-54. DISASSEMBLY - AMBIENT AIR BLOWER.**

a. Move impeller (13, figure 13-9) forward to clear housing (6) then remove housing and gasket (8).

b. Remove impeller and separate impeller fitting (15) from impeller (13) by removing nuts (1), washers (2), and bolts (5).

c. Remove bolts (12) and washers (11) and separate adapter (7) from housing (6).



**13-55. CLEANING - AMBIENT AIR BLOWER.**



Cleaning solvent is flammable and toxic. Provide adequate ventilation. Avoid prolonged breathing of solvent vapors and contact with skin or eyes.

- a. Clean disassembled parts with solvent (C112).
- b. Dry with a clean lint-free cloth.

**13-56. INSPECTION - AMBIENT AIR BLOWER.**

Inspect blower assembly components as follows: (figure 13-9).

- a. Adapters. Inspect adapters (7 and 14) for cracks or breaks in material and for corrosion damage.



**b. Housing.** Inspect blower housing (6) for dents and deformity, cracks, and corrosion damage.

**c. Impeller Fitting.** Inspect impeller fitting (15) for cracks, damaged internal splines, and corrosion damage.

**d. Impeller.** Inspect impeller (13) for deformity, broken welds, cracked or damaged blades, and corrosion damage.

### 13-57. REPAIR OR REPLACEMENT - AMBIENT AIR BLOWER.

#### a. Adapters.

(1) Replace adapter (7 and 14, figure 13-9) if cracked.

(2) Cleanup minor corrosion damage with abrasive cloth (C36), and touch up with primer (C88 or C91). If corrosion damage is severe enough to affect function, replace the adapter.

#### b. Housing.

(1) Replace blower housing (6) if cracked

(2) Clean up minor corrosion damage with abrasive cloth (C36), and touch up with primer (C88 or C91). If corrosion damage is severe enough to affect function, replace the housing.

#### c. Impeller Fitting.

(1) Replace impeller fitting (15) if cracked or for damaged internal splines.

(2) Clean up minor corrosion damage with abrasive cloth (C36) and touch up with primer (C88 or C91). If corrosion damage is severe enough to affect function, replace the impeller fitting.

#### d. Impeller.

(1) Replace impeller (13) with deformed or cracked blades, or broken welds.

(2) Clean up minor corrosion damage with abrasive cloth (C36) and touch up with primer (C88 or C91). If corrosion damage is severe enough to affect function, replace the impeller fitting.

### 13-58. ASSEMBLY - AMBIENT AIR BLOWER.

**a.** Attach impeller fitting (15, figure 13-9) to impeller (13) with four bolts (5), aluminum washers (2) and nuts (1).

**b.** Attach adapter (7) to housing (6) with bolts (12) and aluminum washers (11).

### 13-59. INSTALLATION - AMBIENT AIR BLOWER.

**a.** Position impeller (13) in opening in firewall.

**b.** Place gasket (8) and housing (6) on transmission pad; install six bolts (10) with aluminum washers (9). Torque bolts (10) **15 TO 20** inch-pounds. Secure bolts with lockwire (C137).

**c.** Position impeller (13) in housing (6),

**d.** Place washer (16) under head of bolt (17), and install bolt through fitting (15). Torque bolt (17) **80 TO 100** inch-pounds and lockwire to shank of bolt (5). Use lockwire (C138).

**e.** Install intake and exhaust ducts with clamps and attaching hardware.

**f.** Close hydraulic compartment door and transmission cowling.

### 13-60. VENT AIR CONTROL VALVE.

### 13-61. DESCRIPTION - VENT AIR CONTROL VALVE.

The vent air control valve located between the transmission-driven blower and the ducts distributing air to the crew compartment is an on-off valve. When the ECS is functioning, the valve is normally closed. Lack of bleed air pressure against the valve permits the valve to open, allowing the transmission driven blower to force ambient air into the crew compartment (figure 13-1).

**Premaintenance Requirements for  
Vent Air Control**

Condition	Requirements
Model	AH-1S
Part No. or Serial No.	All
Special Tools	None
Test Equipment	(T18)
Support Equipment	(S12) (S14) (S15)
Minimum Personnel Required	Two
Consumable Materials	(C17) (C63) (C73) (C112) (C124)
Special Environmental Conditions	None

**13-62. REMOVAL - VENT AIR CONTROL VALVE.**

- a. Remove hydraulic compartment access door located on right side of helicopter and aft of pilot door.
- b. Disconnect hose assembly (3, figure 13-10) from regulator (4), loosen nut on opposite end of hose assembly (3), and rotate tube away from regulator.
- c. Remove screw (6), washer (7), and nuts (8). Slide clamp (9) up on flex duct (5) until it is clear of bracket (10).
- d. Remove screw (19), washer (20), and nut (21). Slide clamp (18) upon coupling (17).
- e. Use a round-edged probe to separate coupling (17) from duct assembly (22) and flex duct (5) from valve (11).
- f. Remove screw (14), washer (15), and nut (16). Slide clamp (12) off bracket (13). Lift valve (11), regulator (4), and coupling (17) out of the compartment.
- g. Cover open ends of hose assembly (3) and ducts (5 and 22) to prevent entry of foreign material.

h. Remove coupling (17) from valve (11).

i. Loosen nut (2) and remove regulator (4) from union (1). Remove union from valve (11).

**13-63. DISASSEMBLY - VENT AIR CONTROL VALVE.**

a. Remove nuts (12, figure 13-11), screws (1), washers (11), and cover (3).

b. Remove cotter pin (27; and pin (24) to disconnect links (22 and 25) from rod end connector (8).

c. Remove diaphragm (6) with assembled plate (5) and rod end connector (8). Remove spring (9).

d. Remove screw (4), rod end connector (8), plate (5), and cup (7).

e. Remove links (22 and 25) from butterfly assembly (20).

f. Remove screws (19), stiffener (18), and butterfly assembly (20).

g. Slide shaft (21) out of body and remove spacer (19), bearing (15), special washer (16), and spacer (18) from both sides of body assembly (10).

**13-64. CLEANING - VENT AIR CONTROL VALVE.**

a. Clean bearings (15, figure 13-11) with a clean, lint-free cloth.



**Cleaning solvent is flammable and toxic. Provide adequate ventilation. Avoid prolonged breathing of solvent vapors and contact with skin or eyes.**

b. Clean all parts except bearings with solvent (C112). Dry parts with filtered compressed air at **20 TO 25** psig. Do not spin or dry bearings with compressed air.

**13-65. INSPECTION - VENT AIR CONTROL VALVE.**

a. Inspect cover assembly (3, figure 3-11) for damaged threads in port.

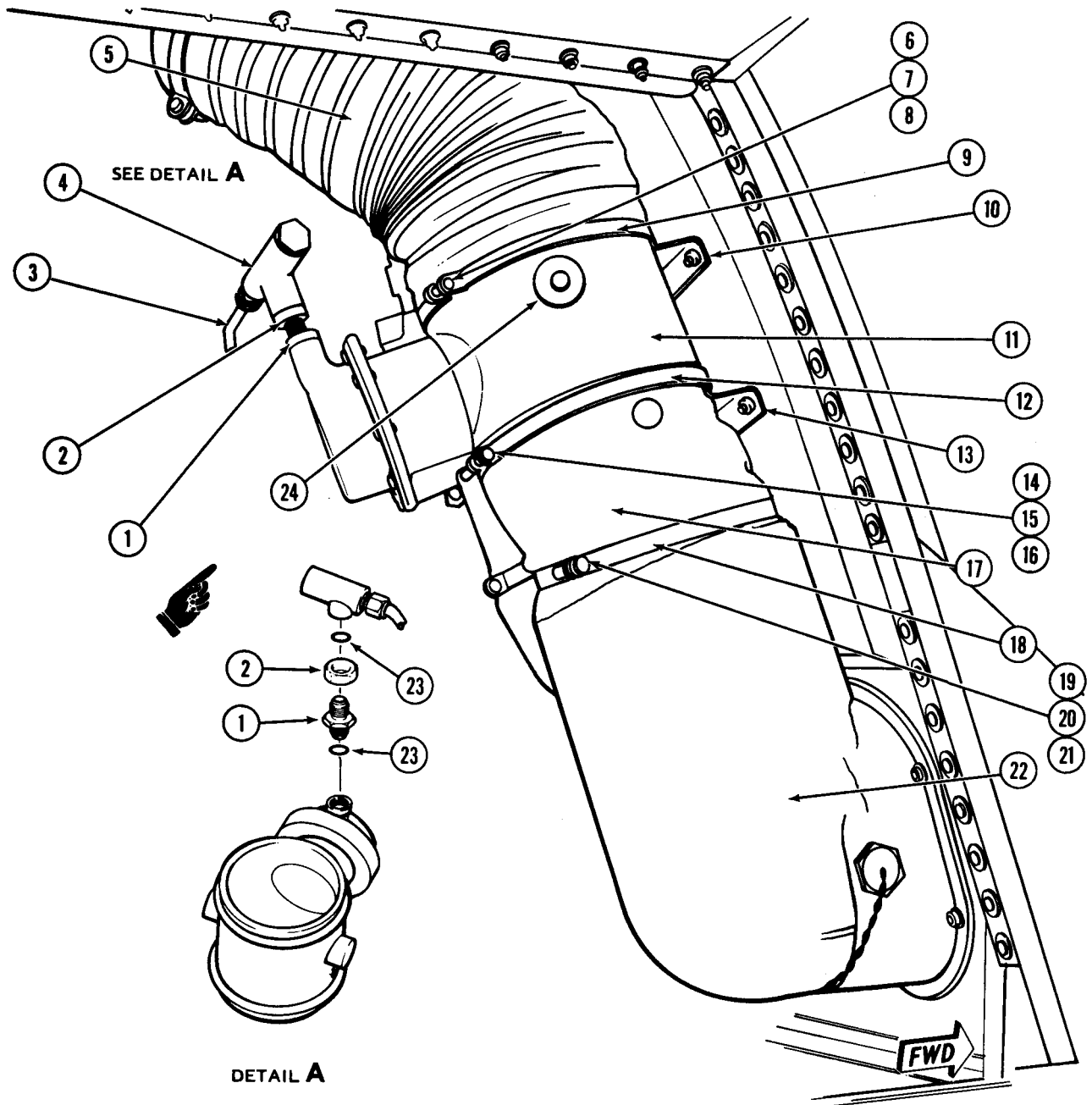

209704-24A

- |                         |                            |                          |
|-------------------------|----------------------------|--------------------------|
| 1. Union                | 9. Clamp                   | 17. Coupling             |
| 2. Nut                  | 10. Bracket                | 18. Clamp                |
| 3. Tube assembly        | 11. Vent air control valve | 19. Screw                |
| 4. Regulator            | 12. Clamp                  | 20. Thin aluminum washer |
| 5. Flex duct            | 13. Bracket                | 21. Nut                  |
| 6. Screw                | 14. Screw                  | 22. Duct assembly        |
| 7. Thin aluminum washer | 15. Thin aluminum washer   | 23. Packing              |
| 8. Nut                  | 16. Nut                    | 24. Boss                 |

Figure 13-10. Vent Air Control Valve – Installation

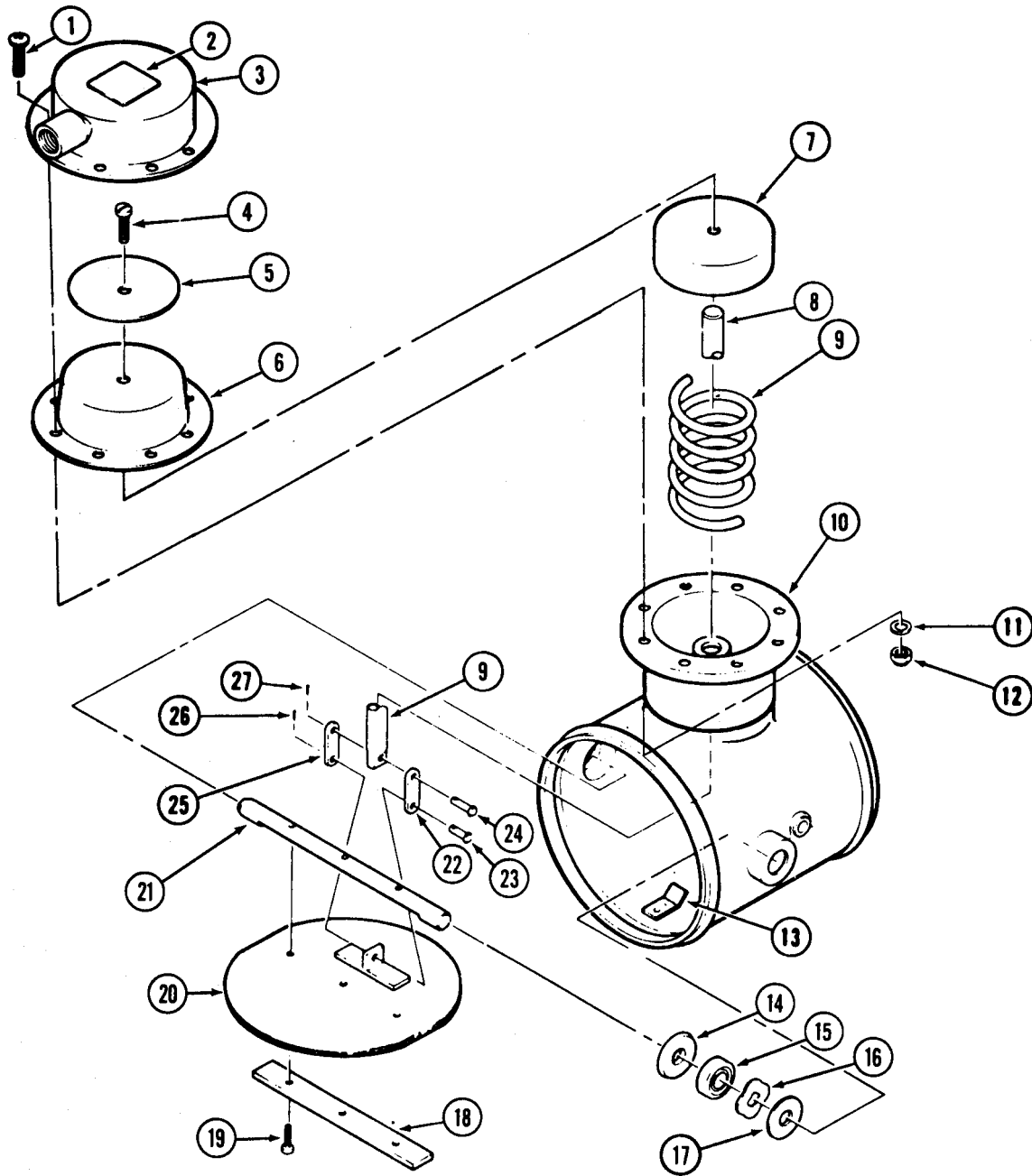

- |                         |                      |                        |
|-------------------------|----------------------|------------------------|
| 1. Screw                | 10. Body assembly    | 19. Screw              |
| 2. Identification plate | 11. Flat washer      | 20. Butterfly assembly |
| 3. Cover                | 12. Self-locking nut | 21. Shaft              |
| 4. Screw                | 13. Stop             | 22. Link               |
| 5. Plate                | 14. Spacer           | 23. Pin                |
| 6. Diaphragm            | 15. Bearing          | 24. Pin                |
| 7. Cup                  | 16. Special washer   | 25. Link               |
| 8. Rod end connector    | 17. Spacer           | 26. Cotter pin         |
| 9. Spring               | 18. Stiffener        | 27. Cotter pin         |

209070-220

Figure 13-11. Vent Air Control Valve

b. Inspect rod and connector (8) for damaged threads and for wear. Minimum diameter is **0.370** inch.

c. Inspect plate (5) and cup (7) for distortion. Also check diameter of cup. Maximum outside diameter is **2.312** inches.

d. Inspect diaphragm (6) for tears, cracks, and distortion.

e. Inspect spring (9) for deformation and for free length of **3.06** inch. Check spring tension. The weight required to compress the spring to **2.25** inches must be **10.4 TO 12.4** pounds. The weight required to compress the spring to **0.95** inch must be **26.6 TO 32.6** pounds.

f. Inspect holes in links (22 and 25) for wear. Manufacturing tolerance is **0.1245 TO 0.1255**. Center to center dimension is **0.745 TO 0.755** inch. No distortion is allowed.

g. Inspect stiffener (18) for deformation.

h. Inspect butterfly (20) for distortion and wear. Minimum diameter is **4.893** inches. Minimum dimension across flats is **4.770** inches.

i. Inspect shaft (21) for deformation and for damaged threads. Check diameter. Minimum diameter is **0.3740** inch.

j. Inspect body assembly (10) for damaged bushings. No scoring is allowed. Inspect stop (13) for secure installation.

k. Inspect bearings (15) for galling and scoring. None allowed.

l. Inspect identification plate (2) for legibility and secure attachment.

### **13-66. REPAIR OR REPLACEMENT - VENT AIR CONTROL VALVE.**

Do not attempt to repair any parts of the control valve. Replace any parts which fail to pass inspections described in paragraph 13-65.

### **13-67. ASSEMBLY - VENT AIR CONTROL VALVE.**

a. Lubricate bearings (15, figure 3-11) with lubricant (C73).

b. Slide shaft (21) partially into body (10) and position spacer (17), special washer (16), bearing (15), and spacer (14) on shaft in sequence illustrated. Install spacer (14) with the beveled side toward bearing (15). Position these parts in boss of body (10) and install corresponding bearing spacers and washer on opposite side.

c. Install links (22 and 25) on butterfly assembly (20) with pin (23) and cotter pin (26).

d. Position butterfly assembly on shaft (21) in same relative position illustrated so that it will be on the correct side of stop (13) when assembly is complete. Secure butterfly assembly to shaft (21) with stiffener (18) and three screws (19). Move the butterfly assembly manually to ensure that it moves freely through full range of travel.

e. Assemble rod end connector (8), cup (7), diaphragm (6), plate (5), and screw (4) in same relative positions illustrated. Install screw (4) snug but do not torque.

f. Make trial installation of parts assembled in preceding step. Align holes in diaphragm with holes in body (10) and insert three screws (1) to maintain alignment. Rotate rod end connector (8) so that it will align with links (22 and 25) and tighten screw (4). Remove diaphragm (6) and attached parts from body assembly.

g. Position spring (9) in body assembly (10) and install diaphragm (6) with attached parts. Secure links (22 and 25) to rod end connector (8) with pin (24) and cotter pin (27). Check diaphragm to ensure that the holes line up with the holes in the body without twisting the diaphragm. Position cover assembly (3) on body assembly with threaded boss oriented with the body assembly (10) and stop (13) as illustrated. Install screws (1), washers (11), and nuts (12).

### **13-68. TESTING - VENT AIR CONTROL VALVE (FIGURES 13-11 AND 13-12).**

a. If the test set-up shown on figure 13-12 is not available, perform functional check on helicopter after installation, paragraph 13-69.

b. If the test set-up shown on figure 13-12 is available, install the vent air control valve as illustrated.

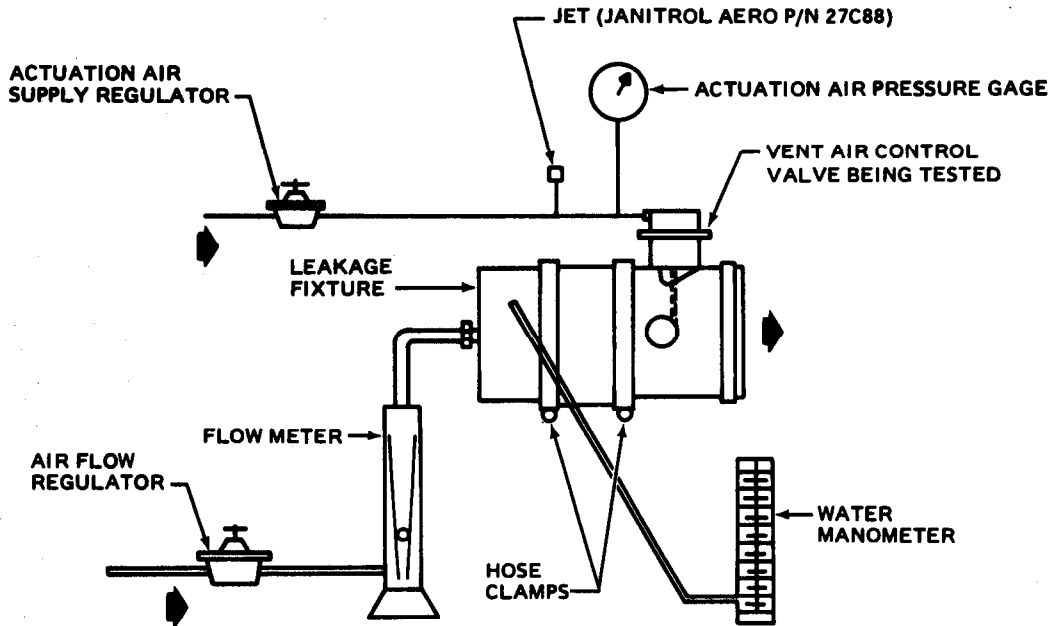

209070-82

**Figure 13-12. Vent Air Control Valve Test Set-up**

c. Adjust pressure at actuation air supply regulator (T18) to apply  $7.0 \pm 0.5$  psig pressure to the vent air control valve. The butterfly assembly should move to full closed.

d. Decrease pressure to vent air control valve to zero. The butterfly assembly (20), figure 13-11) should move to full open.

e. Repeat steps c. and d. except apply  $25 \pm 1.0$  psig pressure to the vent air control valve. The butterfly assembly (20) should be full open while pressure is applied and full closed when pressure is removed.

f. Adjust pressure at the actuation air supply regulator (T18) to apply  $7.0 \pm 0.5$  psig pressure to the vent air control valve and maintain pressure to keep butterfly assembly (20) closed. Adjust air flow regulator to increase pressure until reading on the water manometer (S14) is 27.0 inches. Check the flowmeter. and record the leakage rate across the butterfly assembly. If the leakage rate is more than five cubic feet per minute, remove the vent air control valve from the test set-up and remove one special washer (16, figure 13-11). Reassemble the vent air control valve and repeat the tests.

g. If the vent air control valve fails to pass the tests in steps b. through f., forward the assembly to next higher level of maintenance.

### 13-69. INSTALLATION - VENT AIR CONTROL VALVE.

a. Thread nut (2, figure 13-10) on union (1), Lubricate two packings (23) lightly with hydraulic fluid (C63) or other suitable lubricant and position packings on union (1). Install union (1) on valve (11) and install regulator (4) on union (1). Do not tighten nut (2) at this time.

b. Apply a light coat of adhesive (C17) to lower flange of valve (11). Position coupling (17) on valve. Install clamp (12) with screw (14), thin aluminum washer (15), and nut (16) but do not tighten at this time.

c. Place clamp (18) on duct (22) and place clamp (9) on flex duct (5).

d. Position valve (11) in the right side of the hydraulic compartment with the boss (24) uppermost as illustrated. Slide clamp (12) over bracket (13).



e. Apply a light coat of adhesive (C17) to upper flange of valve (11). Position flex duct (5) on valve (11) and slide clamp (9) into position on the flex duct and also on bracket (10). Install screw (6), thin aluminum washer (7), and nut (8), but do not tighten at this time.

f. Attach tube assembly (3) to regulator (4). Turn the regulator or union (1) and/or rotate valve (11), if required to obtain alignment with hose assembly (3). Tighten nuts at each end of hose assembly (3) and also nut (2).

g. Check clamps (9, 12, and 18) to ensure that they are properly positioned on the ducts and valve and that the two upper clamps are positioned properly on the brackets. Tighten the nuts and screws on each of the three clamps.

h. If the helicopter is operational, perform a functional check of the vent air control valve.

#### NOTE

**The vent air control valve is normally open and is closed by bleed air pressure.**

(1) Ground run the helicopter. Position the HTR/RAIN RMV (ECU) switch to OFF. Open one of the air outlet nozzles in the pilot compartment. There should be a flow of air at ambient temperature. Move the ECU COOL/WARM selector to full WARM and check temperature of air flowing from outlet by feel. Move temperature selector to full COOL and check temperature of air flowing from outlet. The temperature should not change.

(2) Position the HTR OFF, RAIN RMV (ECU) switch to HTR. Repeat the check of the temperature of air flow from outlet nozzle with the temperature selector at full WARM and at full COOL as outlined in step (1). The vent air control valve should be closed and the temperature of the air should change when the temperature selector is changed.

### 13-70. VENTILATING DUCTS.

#### 13-71. DESCRIPTION - VENTILATING DUCTS.

The ducts transport air from the inlet duct into the cabin and are of two types, rigid and flexible. They are attached to components by couplings and clamps (figure 13-1).

#### 13-72. REMOVAL - VENTILATING DUCTS.

Remove insulation, attaching hardware and /or clamps and remove components.

### 13-73. INSPECTION - VENTILATING DUCTS.

a. Ducting and insulation for damage, chafing, or leakage.

b. Clamps and connections for security and for leakage around clamps.

c. Intake screen for obstruction.

### 13-74. REPAIR OR REPLACEMENT - VENTILATING DUCTS.

a. Replace damaged or leaking ducts.

b. Clean intake screen if clogged, using compressed air.

c. Tighten clamps or connection if loose or leaking.

d. Repair insulation if torn or damaged.

### 13-75. INSTALLATION - VENTILATING DUCTS.

#### CAUTION

**When installing ducts, insure that adequate clearance exists between the ducts and the cyclic control tubes to allow free movement over the full travel range of the tubes.**

a. Position ducts and secure with hardware and/or clamps.

b. Install insulation and secure with tape (C122).

### 13-76. AIR CONTROL VALVE.

#### 13-77. DESCRIPTION - AIR CONTROL VALVE.

An air control valve (figure 13-1) is operated by a cable control from the pilot instrument panel. The valve regulates the amount of air entering the distribution system. When fully closed, all air to crew compartment is shut off, except to pilot seat cushion. When cabin air is desired, the control should be full out and air control valve full open.

### **13-78. REMOVAL - AIR CONTROL VALVE.**

a. Remove cotter pin, washer, and pin from clevis end of control cable at control valve and duct assembly.

b. Remove screws, washers, and nuts from clamps, brackets, and supports securing heat or vent air pull control (16, figure 13-1) to fuselage and ducting.

c. Loosen locknut from control valve housing. Remove control from helicopter.

### **13-79. INSPECTION - AIR CONTROL VALVE.**

a. Inspect control valve (10, figure 13-1) for locking in all positions. Lock should hold a load of 8 pounds without slippage. Apply 8 pounds pressure using a force gage (fish scale).

b. Inspect control, housing, cable, and clevis for damage and corrosion.

c. Inspect valve in duct assembly for freedom of operation and range of travel.

d. Control valve assembly is nonrepairable and must be replaced if it fails to meet inspection requirements.

### **13-80. INSTALLATION - AIR CONTROL VALVE.**

a. Route heat or vent air pull control (16, figure 13-1) through instrument panel opening through fuselage structure to air control valve and duct assembly.

b. Secure assembly with previously removed screws, washers, clamps, brackets, and supports.

c. Attach clevis end of heat or vent air pull control (16) to lever on air control valve and duct assembly. Secure with pin, washers, and cotter pin.

d. Check heat or vent air pull control (16) for freedom of movement and locking in intermediate position.

e. With heat or vent air pull control (16) pushed full in, check that lever on valve and duct assembly is

approximately perpendicular to surface of duct. With control full out, lever on valve should be approximately horizontal to surface of duct.

### **13-81. AIR OUTLET VALVES.**

#### **13-82. DESCRIPTION - AIR OUTLET VALVES.**

The outlet valves (7, 12, and 15, figure 13-1) are located in gunner and pilot compartments or at left and right sides of instrument panels. The air outlet valves are adjustable to direct flow and/or amount of conditioned air, as desired. The defog outlets (7, figure 13-1) are located in the pilot compartment at right and left sides of instrument panel console. The defog outlets consist of a tab slider mounted to plenum assembly. Adjustment of slider directs conditioned air to defog canopy.

#### **13-83. REMOVAL - AIR OUTLET VALVES.**

Remove attaching screws and washers and remove air outlet valves.

#### **13-84. INSPECTION - AIR OUTLET VALVES.**

a. Inspect air outlet valves (7, 12, and 15, figure 13-1) for condition and operation.

b. Inspect defog outlets slider tab and plenum for wear and damage.

c. inspect connecting ducts for serviceability.

#### **13-85. REPAIR OR REPLACEMENT - AIR OUTLET VALVES.**

Replace valves that do not meet inspection requirements.

#### **13-86. INSTALLATION - AIR OUTLET VALVE.**

a. Position air outlet valves on connecting ducts.

b. Install attaching screws and washers.

### **13-87. RAIN REMOVAL SYSTEM.**

#### **13-88. DESCRIPTION - RAIN REMOVAL SYSTEM (FIGURE 13-13).**

The rain removal system consists of a series of tubes from the engine compressor section to the nozzle next

to lower windshield where it is vented. This nozzle provides air to force moisture from the outer surface of windshield in a standard pattern (figure 13-15). Seven small nozzles are grouped together and distribute the air from the nozzle assembly. A selector switch on the pilot instrument panel allows bleed air to flow through the tubes and out the vent to the windshield. A drain valve (16) is provided to prevent the collection of moisture in tube system.

### 13-89. RAIN REMOVAL MANIFOLD.

#### 13-90. DESCRIPTION - RAIN REMOVAL MANIFOLD.

There are seven small nozzles which are grouped together in line and direct the flow of air from the manifold assembly to the windshield.

#### 13-91. REMOVAL - RAIN REMOVAL MANIFOLD.

a. Remove the following components from the gunner instrument panel.

- (1) Gyro horizon
- (2) Airspeed indicator
- (3) Tow control set
- (4) **P E** ARC 14 Radio  
**M** Doppler Navigation Set

b. Disconnect tube (12, figure 13-13) from manifold assembly (4).

c. Remove lockwire (11), loosen ring (10), and disconnect bleed air tube from manifold.

d. Remove four screws (6) and washers (7). Separate manifold from helicopter structure.

e. Loosen nut (23) and remove duct assembly (22) from manifold. Remove manifold from helicopter,

#### 13-92. INSPECTION - RAIN REMOVAL MANIFOLD.

Inspect manifold assembly (4, figure 13-13) for cleanliness and damage.

#### 13-93. REPAIR OR REPLACEMENT - RAIN REMOVAL MANIFOLD.

Replace rain removal manifold assembly if damaged. No repairs are acceptable.

#### 13-94. INSTALLATION - RAIN REMOVAL MANIFOLD.

a. If not previously accomplished, remove components listed in paragraph 13-91, a.

b. Position rain removal manifold (4, figure 13-13) in helicopter and position duct assembly (22) on the manifold. Tighten nut (23).

c. Hold rain removal manifold next to helicopter structure and install four screws (6) and washers (7).

d. Position bleed air tube on left end of manifold and tighten ring (10), lockwire ring (10) with lockwire (C137).

e. Install tube (12) on left end of manifold assembly.

f. Install the following components in the gunner instrument panel.

- (1) Gyro horizon
- (2) Airspeed Indicator
- (3) Tow control set
- (4) **P E** ARC 14 Radio  
**M** Doppler Navigation Set

g. Perform functional check of components installed in step f.

h. Perform operational check of rain removal system.

#### 13-95. TEMPERATURE CONTROL VALVE.

#### 13-96. DESCRIPTION - TEMPERATURE CONTROL VALVE.

A windshield clearing temperature control valve (18), figure 13-13) is located at F.S. 46 and W.L. 67.00 in the ambient air line to the manifold. The valve is

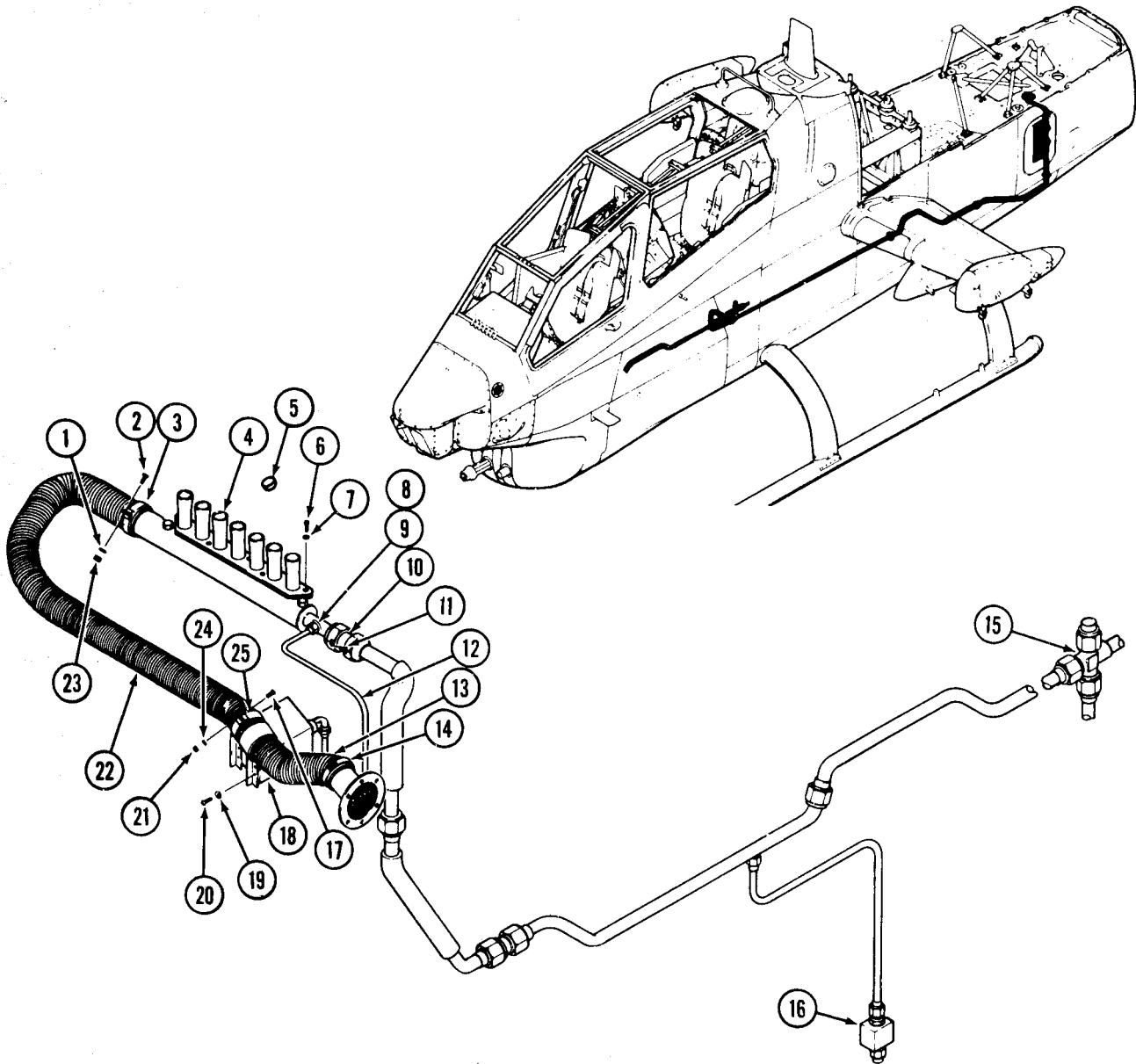

- |                      |                               |
|----------------------|-------------------------------|
| 1. Washer            | 13. Duct assembly             |
| 2. Screw             | 14. Clamp                     |
| 3. Clamp             | 15. Air distribution valve    |
| 4. Manifold assembly | 16. Drain valve               |
| 5. Thermal switch    | 17. Screw                     |
| 6. Screw             | 18. Temperature control valve |
| 7. Washer            | 19. Washer                    |
| 8. Union             | 20. Screw                     |
| 9. Packing           | 21. Nut                       |
| 10. Ring             | 22. Duct assembly             |
| 11. Lockwire         | 23. Nut                       |
| 12. Tube             | 24. Washer                    |
|                      | 25. Clamp                     |

209070-219

Figure 13-13. Rain Removal Manifold

actuated by bleed air pressure and controlled by a solenoid. The valve is normally open to supply ambient air to the manifold (4). A thermal switch (5), imbedded in the windshield, controls valve operation. When the system is turned on, the valve closes. The valve remains closed and bleed air is supplied to the nozzle assembly until the thermal switch opens at **125 degrees F (52 degrees C)**, de-energizing the valve solenoid. The valve then opens and supplies ambient air to the manifold. The cooler ambient air mixes with bleed air flow as it is distributed through nozzles to the windshield.

### **13-97. REMOVAL - TEMPERATURE CONTROL VALVE.**

- a. Disconnect electrical plug at temperature control valve (18, figure 13-13).
- b. Disconnect one end of tube (12) at temperature control valve (18).
- c. Remove screws (20) and washers (19).
- d. Remove nuts (21), washers (24), screws (17), and clamps (14 and 25) from each end of temperature valve. Remove temperature control valve from ducts (13 and 22) and helicopter.

### **13-98. INSPECTION - TEMPERATURE CONTROL VALVE.**

- a. Inspect temperature control valve for damage.
- b. Apply 12 Vdc power (S12) to determine if part is operating properly.

### **13-99. REPAIR OR REPLACEMENT - TEMPERATURE CONTROL VALVE.**

Replace temperature control valve if damaged or inoperative. No repairs are acceptable.

### **13-100. INSTALLATION - TEMPERATURE CONTROL VALVE.**

- a. Install washers (19, figure 13-13) and screws (20) to attach temperature control valve (18) to structure.
- b. Slip end of ducts (13 and 22) over ends of temperature control valve and install clamp (14), screws (17), washers (24), and nuts (21).
- c. Connect one end of tube (12) to temperature control valve.
- d. Connect electrical plug to temperature control valve (18).

### **13-101. RAIN REMOVAL THERMAL SWITCH.**

#### **13-102. DESCRIPTION - RAIN REMOVAL THERMAL SWITCH.**

A thermal switch mounted in the windshield (figure 13-14) provides thermal protection to the windshield. When rain removal air exceeds preset limits, the switch opens and actuates temperature control valve (18, figure 13-13) to prevent overheating the windshield.

#### **13-103. INSPECTION - RAIN REMOVAL THERMAL SWITCH.**

Switch should open at **125 ±5 degrees F (52 ±3 degrees C)** and close at **100 ±5 degrees F (38 ±3 degrees C)**.

#### **13-104. REMOVAL - RAIN REMOVAL THERMAL SWITCH (FIGURE 13-14).**

Press thermal switch (figure 13-14) from windshield and disconnect wiring.

#### **13-105. INSTALLATION - RAIN REMOVAL THERMAL SWITCH.**

- a. Scrape old sealant from windshield and clean area by using crocus cloth (C37) and damp cloth to remove old adhesive from windshield.
- b. Prepare adhesive (C14) according to manufacturer's instructions.

#### **NOTE**

**Pot life of adhesive at room temperature is approximately 30 minutes.**

- c. Apply light coat of adhesive (C14) to mating surface of thermoswitch and windshield and press thermoswitch into opening in windshield. Allow adhesive to cure in accordance with table 1-11.

#### **NOTE**

**Remove any adhesive accidentally applied to outside surface of thermoswitch.**

- d. Connect electrical wiring (Appendix F).

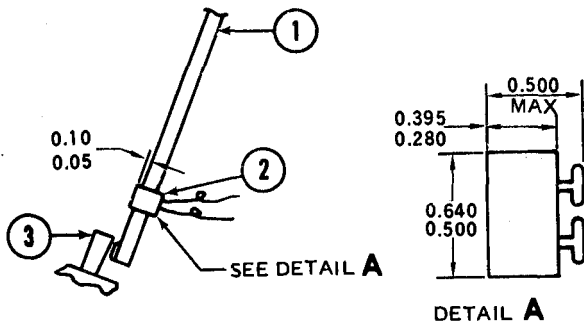

- 1. Windshield
- 2. Thermostwitch
- 3. Windshield frame

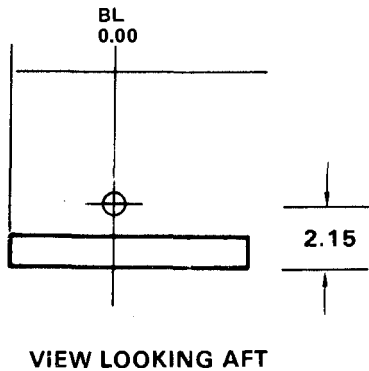

ALL DIMENSIONS IN INCHES UNLESS OTHERWISE NOTED.

209073-3A

**Figure 13-14. Rain Removal Thermal Switch — Installation**

**13-106. RAIN REMOVAL TUBING.**

**13-107. DESCRIPTION - RAIN REMOVAL TUBING.**

A series of tubes is located from the engine compressor section to the rain removal manifold assembly. Also, a drain tube is provided to prevent the collection of moisture in tube system.

**13-108. REMOVAL - RAIN REMOVAL TUBING.**

- a. Remove panel on left side of helicopter below windshield.
- b. Remove panels (28, 30, 32, 33, 36, and 37, figure 2-3) in order to gain access to tubing.
- c. Remove attaching hardware and/or clamps and couplings, and remove components.

**13-109. INSPECTION - RAIN REMOVAL TUBING.**

Inspect tubing for security, damage, and leaks (figure 13-1).

- b. Inspect couplings for leakage and security.
- c. Check drain valve (16, figure 13-13) for proper operation.

**13-110. REPAIR OR REPLACEMENT - RAIN REMOVAL TUBING.**

- a. Tighten couplings if loose or leaking.
- b. Replace drain valve (16, figure 13-13) if damaged or inoperative.
- c. Replace tubing if damaged.

**13-111. INSTALLATION - RAIN REMOVAL TUBING:**

- a. Install hardware and/or clamps and couplings to attach tubing.
- b. Install panels (28,30,32,33,36, and 37,figure 2-3).
- c. Install panel left side of helicopter below windshield.

**13-112. RAIN REMOVAL VALVE.**

**13-113. DESCRIPTION - RAIN REMOVAL VALVE.**

The rain removal valve (9, figure 13-1) serves to route a portion of engine bleed air to the helicopter windshield rain removal nozzle. When the pilot ECS switch is positioned to RAIN RMV, the solenoid

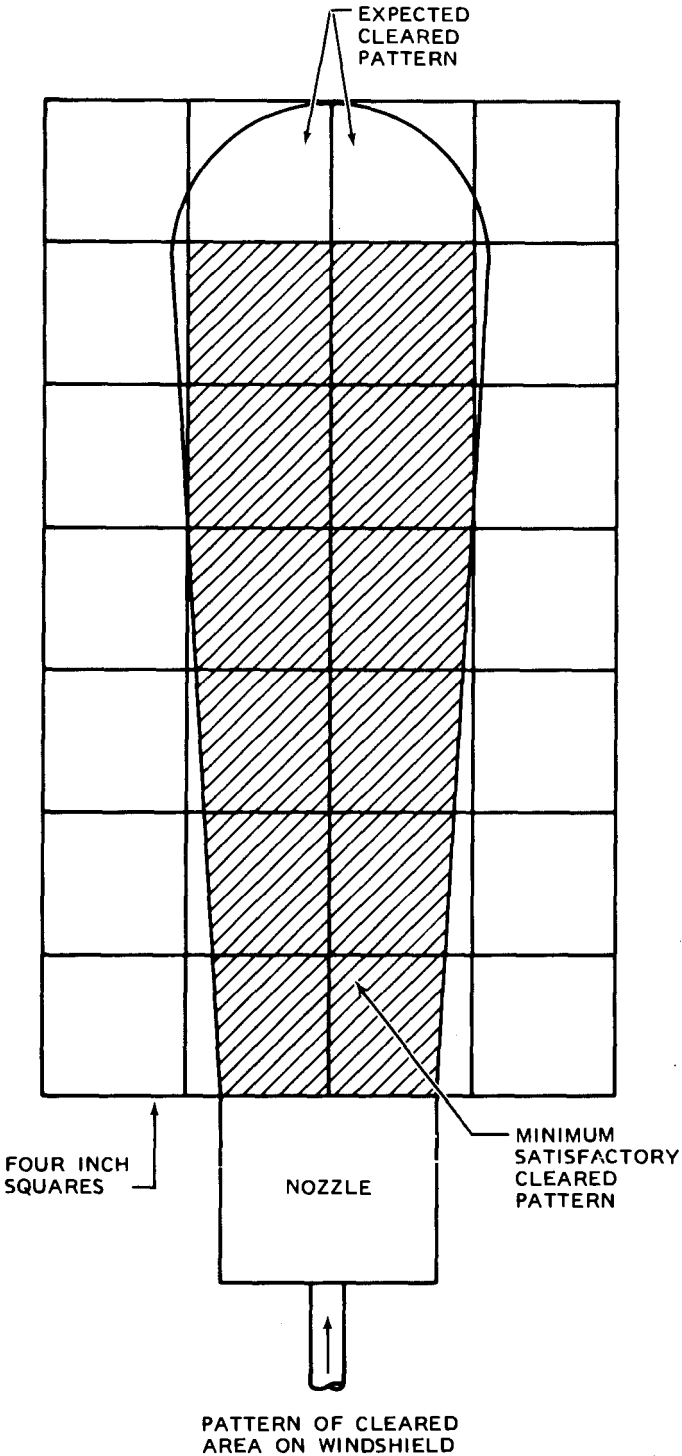

Figure 13-15. Rain Removal Nozzle and Cleared Air Pattern

actuated pilot valve allows a small amount of bleed air to vent through a series of flow-control orifices to atmosphere. This creates a pressure imbalance which causes line pressure to lift the poppet assembly off the seat inside the body. This allows bleed air to flow to the rain removal nozzle located at the base of the windshield.

**13-114. ADJUSTMENT - RAIN REMOVAL VALVE.**

**Premaintenance Requirements for Inspection and Adjustment of Rain Removal Valve**

Condition	Requirements
Model	AH-1S
Part No. or Serial No.	All
Special Tools	(T76) (T2)
Test Equipment	None
Support Equipment	(S12)(S15)
Minimum Personnel Required	Two
Consumable Materials	(C32) (C36) (C37) (C59) (C112) (C137)
Special Environmental Conditions	None

**13-115. FUNCTIONAL TEST - RAIN REMOVAL VALVE.**

**NOTE**

If there are any malfunctions during this test, refer to Troubleshooting Chart, paragraph 13-116.

a. Attach solenoid leads to a source of 18-30 Vdc electrical power (S12) that is controlled by a switch.

b. Cap one of the open ports on the valve body and attach a source of 100 psig compressed air (S15) to the opposite port. Turn the air pressure on and regulate to 100 psig.

c. Cycle the valve ten times and record time required to open and close. The tolerance is 0.5 to 2.0 seconds. After last actuation, measure leakage at the normally closed port. Maximum allowable leakage is 0.05 pounds per minute.

**13-116. TROUBLESHOOTING - RAIN REMOVAL VALVE.**

**NOTE**

Before using this table, ensure all normal operational checks have been performed. If a malfunction occurs which is not listed in this table, notify the next higher maintenance level.

**Table 13-2. Troubleshooting Rain Removal Valve**

CONDITION

TEST OR INSPECTION

**CORRECTIVE ACTION**

1. Valve does not open when energized.

STEP 1. Perform solenoid coil resistance test. Refer to paragraph 13-120 b.

If resistance is not within limits, replace solenoid (paragraph 13-123).



Table 13-2. Troubleshooting Rain Removal Valve (Cont)

## CONDITION

## TEST OR INSPECTION

## CORRECTIVE ACTION

2. Valve does not open or close within allowable time limits (**0.5 to 2.0** seconds).

STEP 1. Check for excessive friction on Teflon lip seal or roughness on sliding surfaces (paragraph 13-120).

**Disassemble the valve, polish out burrs, relubricate, and reassemble (paragraph 13-121).**

3. Valve leaks excessively in closed position.

STEP 1. Inspect poppet assembly seat seal to determine if damaged or worn (figure 13-17).

**If surface of seat seal is slightly damaged, dress off surface. If damage is deep, replace the poppet assembly (paragraph 13-121).**

STEP 2. Inspect seal lip in valve body to determine if pitted or scratched (figure 13-17).

**If seal lip is pitted or scratched, replace valve body (paragraph 13-123).**

### 13-117. REMOVAL - RAIN REMOVAL VALVE.

- a. Remove left panel (5, figure 2-3).
- b. Disconnect electrical connector to solenoid assembly (1, figure 13-16) from valve adapter (6).
- c. Disconnect lines and remove the valve.

### 13-118. DISASSEMBLY - RAIN REMOVAL VALVE.

- a. Index adapter (6, figure 13-16), gasket (9), cap (11), and body (17) with indelible ink marker so that these parts can be reassembled in the same relative position.
- b. Remove lockwire and remove solenoid (1), spring (2), and armature (3).
- c. Hold nuts (19) and remove bolts (4) and washers (5 and 18).

- d. Remove adapter (6), packing (7), spacer (8), gasket (9), and cap (11). Remove packing (12) from cap (11).

- e. Remove spring (13) and poppet (16). Remove seal (14) from poppet.

### 13-119. CLEANING - RAIN REMOVAL VALVE.

**WARNING**

**Cleaning solvent is flammable and toxic. Provide adequate ventilation. Avoid prolonged breathing of solvent vapors and contact with skin or eyes.**

- a. Clean disassembled parts with solvent (C112).
- b. Dry with a clean lint-free cloth.

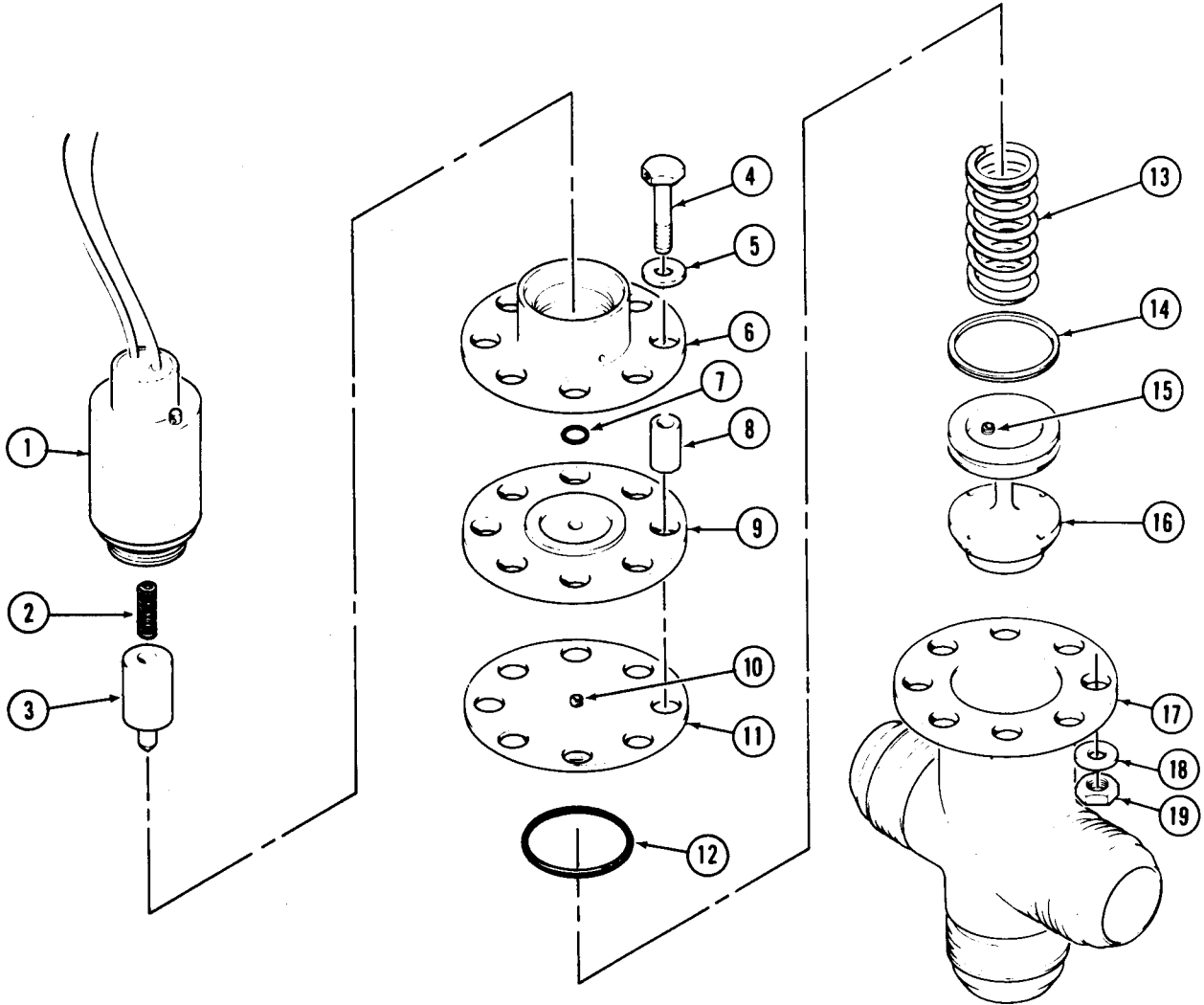

209070-182A

- |                                  |                       |
|----------------------------------|-----------------------|
| 1. Solenoid assembly             | 11. Cap               |
| 2. Spring                        | 12. Packing           |
| 3. Armature                      | 13. Spring            |
| 4. Bolt                          | 14. Teflon lip seal   |
| 5. Thin steel washer             | 15. Orifice           |
| 6. Adapter                       | 16. Poppet assembly   |
| 7. Packing                       | 17. Body              |
| 8. Spacer                        | 18. Thin steel washer |
| 9. Graphite filled teflon gasket | 19. Nut               |
| 10. Orifice                      |                       |

Figure 13-16. Rain Removal Valve

**13-120. INSPECTION - RAIN REMOVAL VALVE.**

a. Use a strong light and magnifying glass to perform visual inspections in the following steps.

b. Inspect solenoid (1, figure 13-16) for evidence of leakage and deterioration at seams. Inspect electrical wires and threads for damage. Check electrical resistance of the solenoid with a multi meter (T2). Attach a lead from multimeter (T2) to each solenoid wire. Read resistance on RX1 scale. If the reading does not fall between **35 and 38** ohms, replace solenoid.

c. Inspect adapter (6) for damaged threads, corrosion, mechanical damage, and distortion.

d. Inspect spacer (8), cap (11), spring (2), and spring (13) for corrosion, mechanical damage and distortion. Inspect orifice (10) for damage and for secure installation in cap.

**NOTE**

**The seat seal referred to in step e. is installed in the poppet with a sleeve guide and then the lip of the poppet is spin-formed to retain these parts. See the sectional view of the poppet on figure 13-17 adjacent to index (7). The area between the poppet and the sleeve guide is sealed pressure tight with high temperature epoxy. The seat seal cannot be removed and replaced without destroying the holding lip, but minor damage can be dressed out. Refer to paragraph 13-121.**

e. Inspect poppet (16, figure 13-16) for nicks in grooves of seal (14). Inspect sliding surface for galling and scoring. Inspect orifice (15) for damage and secure installation in poppet. Inspect seat seal in the end of poppet that contacts seat surface in body bore (7, figure 13-17) for scratches and nicks.

f. Inspect gasket (9, figure 13-16) for breaks and distortion in the thin wall sections adjacent to bolt holes. Inspect the pilot seat surface (3, figure 13-17) for radius of **0.007** inch or more which would require replacement. Replace gasket if nicks or scratches are found in the seat surface.

g. Inspect armature (3, figure 13-16) at taper and seat area for roughness and wear.

h. Inspect body (17) for damaged threads. Inspect the sliding surfaces for scoring or scratches. Check seat surface (7, figure 13-17) for radius of **0.020** or more which would require replacement of the body. Replace seat surface if nicked or pitted.

i. Inspect spring rate for springs (1 and 5) for rate within limits shown.

j. Inspect armature to poppet bore (2) for wear in excess of tolerance shown.

k. Inspect poppet to body bore (6) for wear in excess of tolerance shown.

**13-121. REPAIR OR REPLACEMENT - RAIN REMOVAL VALVE.**

a. Install packings (7 and 12, figure 13-15) and Teflon lip seal (14) when the valve is assembled.

b. Replace all parts which fail to pass inspections described in paragraph 13-120.

c. Polish out minor damage on the seat seal on poppet (16, figure 13-16). If the seat seal is nicked or damaged, replace the entire poppet (16).

d. Polish out minor scoring, nicks, and burrs on outside areas. Work area until surface is smooth but do not alter concentricity. Use abrasive cloth (C36) on aluminum parts and then touch up with chemical film (C31). Use crocus cloth (C37) on other parts.

**13-122. FUNCTIONAL TEST - RAIN REMOVAL VALVE.**

Refer to paragraph 13-115.

**13-123. ASSEMBLY - RAIN REMOVAL VALVE.**

a. Position tool (T76) on poppet (figure 13-18).

b. Lubricate Teflon lip seal with a thin film of silicone grease (C59) and position on tool with open end facing down as illustrated. Slide the seal down the tapered wall of the tool and into the groove on the poppet.

c. Allow the Teflon lip seal to stabilize for five minutes, and then use a round toothpick, or similar non-metallic blunt-ended rod, to work the lip of the

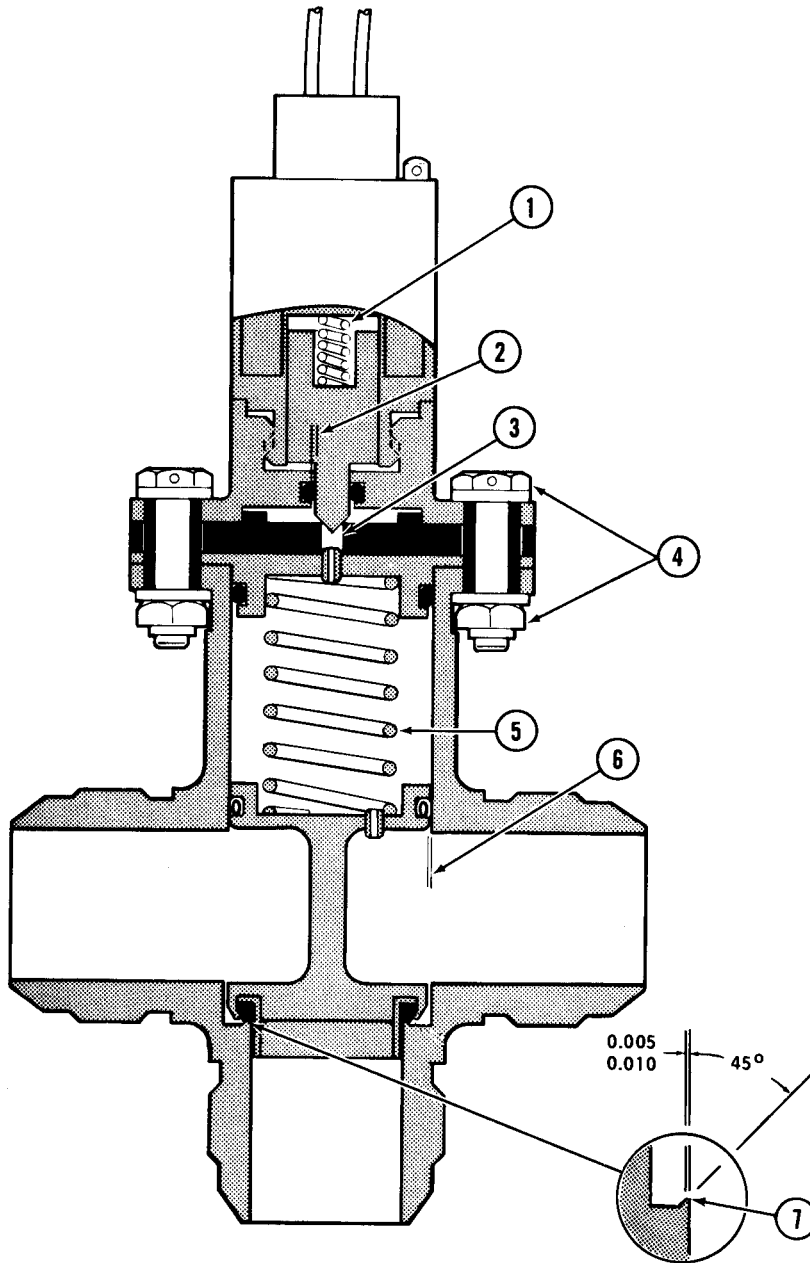

209070-183

Figure 13-17. Limits Chart — Air Distribution Valve  
(Sheet 1 of 2)

ITEM	NOMENCLATURE	MIN.	MAX.	REPLACE
1	Armature Spring rating	58 IN-LB	71 IN-LB	Below or Above
2	Armature Poppet to Adapter bore	0.003	0.006	0.008
3	Seat Surface on Gasket bore (formation of seat surface to pointed poppet is permissible)	0.002R	0.005R	0.007R
4	Bolt to Nut torque	15 IN-LB	17 IN-LB	N/A
5	Poppet Spring rating	0.62 IN-LB	0.78 IN-LB	Below or Above
6	Sliding surfaces of Poppet to body bore	0.124	0.127	0.130
7	Seat surface in body bore	0.005R	0.010R	0.020R

ALL DIMENSIONS ARE IN INCHES UNLESS OTHERWISE NOTED.

209072-8-2C

Figure 13-17. Limits Chart — Air Distribution Valve  
(Sheet 2 of 2)

seal out until it extends past the surface of the poppet equally on all sides.

d. Lubricate sliding surfaces of poppet (16, figure 13-16) and body (17) with a thin film of grease (C59). Slide poppet into position in body and place spring (13) on top of poppet.

e. Lubricate packing (12) with grease (C59) and install packing on cap (11).

f. Observe index marks made on adapter (6), gasket (9), cap (11), and body (17) at time of disassembly and install these parts with the index mark aligned and with spacers (8) in place. Install bolts (4), washers (5 and 18) and nuts (19). Hold nuts and tighten bolts evenly in small increments until a torque of 15 ±2 inch-pounds is applied to each bolt.

g. Lubricate packing (7) and sliding surface of armature (3) with silicone grease (C59) and install packing in adapter (6). Install armature (3), spring (2) and solenoid (1). Lockwire solenoid from drilled hole in lug near leads to one of drilled head bolts (4) with lockwire (C137).

### 13-124. INSTALLATION - RAIN REMOVAL VALVE.

- a. Install electrical connector to the valve.
- b. Connect lines to the valve.
- c. Install left panel (9, figure 2-3).

## SECTION II. AIR COOLING SYSTEMS

### 13-125. AMBIENT AND CONDITIONED COOLING.

### 13-126. DESCRIPTION - AMBIENT AND CONDITIONED COOLING (Section I).

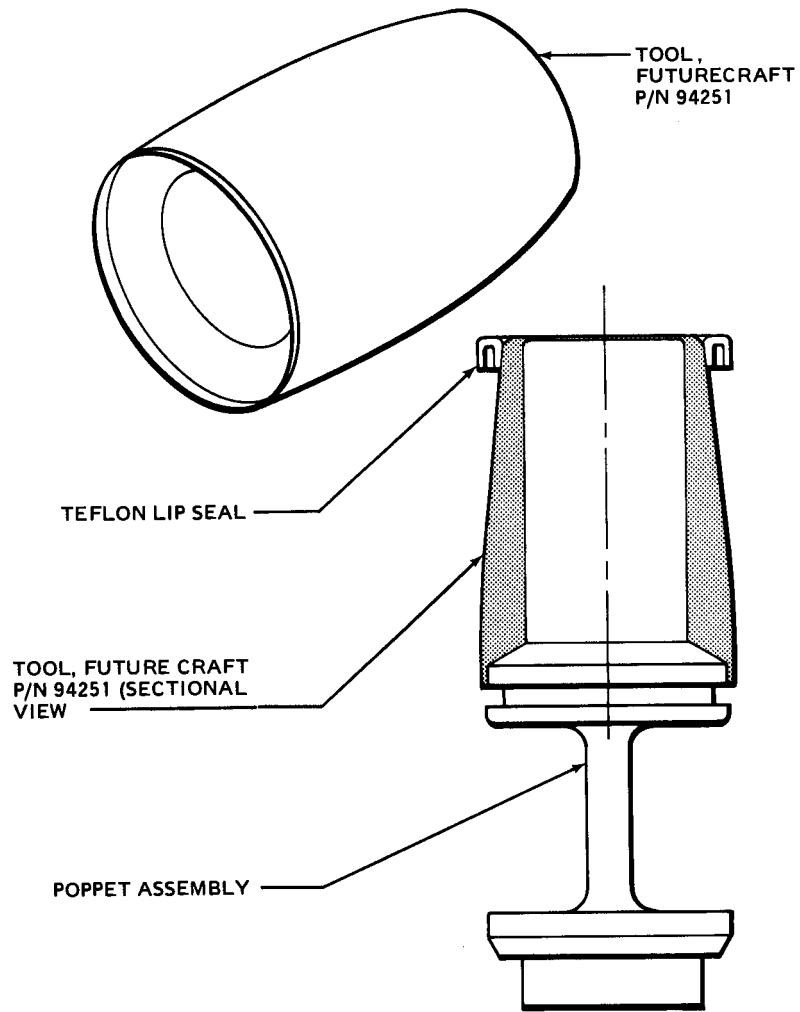

209900-357

Figure 13-18. Tool Application — Teflon Lip Seal Installation

**CHAPTER 14**  
**HOISTS AND WINCHES**

(Not Applicable)





**CHAPTER 15**  
**AUXILIARY POWER PLANTS**

(Not Applicable)



**CHAPTER 16**  
**MISSION EQUIPMENT**

**16-1. GENERAL.**

This chapter contains maintenance instructions for the fire control subsystems and the armament subsystems.

**16-2. FIRE CONTROL SUBSYSTEMS.**

**16-3. DESCRIPTION- FIRE CONTROL SUBSYSTEMS.**

a. The fire control subsystems provide a means for accurately acquiring and tracking targets, and for firing of the turret subsystem. 2.75 inch folding fin aerial rockets and TOW missile subsystem. The fire control subsystems include the following:

- P E** Pilot reflex sight
- Helmet sight subsystem
- Stabilized telescopic sight unit
- MCN** Airborne laser tracker or FLIR missile tracker
- M** Airborne laser tracker
- M** Head up Display
- M** Fire control computer
- M** Air data subsystem
- Gunner controls and indicators
- Pilot controls and indicators
- Interface control unit
- Rocket management subsystem

b. Refer to chapter 9 in this manual for further information and maintenance data on all fire control subsystems except as indicated in paragraphs 16-4 through 16-9 below.

**16-4. P E PILOT PILOT REFLEX SIGHT.**

**16-5. P E DESCRIPTION DESCRIPTION - PILOT REFLEX SIGHT.**

The pilot reflex sight assembly M73 is located above the pilot instrument panel. It provides an illuminated, projected reticle image for pilot use when firing the wing stores, or turret weaponry during fixed forward mode of fire. q For the wing stores, the pilot reads ballistic data cards for information used to adjust the elevation/depression knob, q or estimates range to adjust elevation using short medium or long range witch. For turret weaponry, the range potentiometer .s used to obtain correct gun elevation.

**16-6. P E MAINTENANCE MAINTENANCE - PILOT REFLEX SIGHT.**

Refer to TM 9-1090-203 series manuals for additional information and maintenance procedures. Refer to paragraph F-6 in this manual for airframe armament electrical equipment list, and paragraph F-9 (turret system) for airframe wiring diagrams.

**16-7 M HEAD UP DISPLAY.**

**16-8. M DESCRIPTION DESCRIPTION - HEAD UP DISPLAY.**

The pilot Head Up Display is located above the pilot instrument panel. It provides illuminated symbology for pilot use when firing the wing stores or turret weaponry during fixed forward mode of fire, display navigation information, range to target, and TOW launch window.

**16-9. MAINTENANCE - HEAD UP DISPLAY.**

Refer to TM 9-1270-220-13 and TM 9-1270-220-13P manuals for additional information and maintenance procedures. Refer to paragraph F-6 in this manual for airframe armament electrical equipment list, and paragraph F-9 (turret system) for airframe wiring diagrams.

**16-9.1. MCN FLIR CONTROL PANEL.**

**16-9.2. MCN DESCRIPTION - FLIR CONTROL PANEL.**

The FLIR control panel (FCP) is mounted inboard of the lower left gunner console. The FCP provides controls and indicators necessary to operate FLIR system and provides indicators for display of the FLIR subsystem status and BIT results.

**16-9.3. MAINTENANCE - FLIR CONTROL PANEL.**

Refer to TM 9-1425-473-20 for additional information and maintenance procedures. Refer to paragraph F-6 in this manual for airframe armament electrical equipment list and paragraph F-9 for airframe wiring diagrams.

**16-10. HELMET SIGHT SUBSYSTEM.**

**16-11. DESCRIPTION - HELMET SIGHT SUBSYSTEM.**

a. The helmet sight subsystem (HSS) M136 is interfaced with the turret weapons subsystem and the telescopic sight unit (TSU) through the interface control unit (IFCU) to provide a hands-off sighting system. This system enables the gunner or pilot to aim the turret weapons, and allows the gunner or pilot to quickly acquire a target for the TSU.

b. The HSS consists of two helmet sight assemblies, one each for pilot and gunner, mounted on the SPH-4 helmets; two linkage assemblies, one each for pilot and gunner, mounted to the cockpit left canopy side frame; and an electronic interface assembly mounted on the rear cockpit bulkhead.

**16-12. MAINTENANCE - HELMET SIGHT SUBSYSTEM.**

Refer to TM 9-1270-212-14 manual for additional information and maintenance procedures. Refer to paragraph ~ 9-414 or **F M 9-498** 9-498 in this manual for airframe armament system circuitry information and maintenance procedures. Refer to paragraph F-6 for airframe armament electrical equipment list, and paragraph F-9 for airframe wiring diagrams.

**16-13. ARMAMENT SUBSYSTEMS.**

**16-14. TURRET WEAPONS SUBSYSTEM.**

**16-15. P DESCRIPTION - Turret Weapons Subsystem M28A3.**

The turret weapons subsystem M28A3 is an electrohydraulic dual weapon system providing rapid and voluminous fire power. The turret weapons subsystem consists of a pilot control panel, gunner control panel, turret assembly, M134 7.62mm machine gun, 40mm grenade launcher, ammunition feed system, electronic components, and a pilot reflex sight. All necessary electrical and hydraulic disconnects are installed on a shelf in the forward ammunition compartment. The turret weapons subsystem interfaces with the M136 helmet sight subsystem (HSS) and the turret control portion of the stabilized telescopic sight unit (TSU) of the M65 TOW missile subsystem.

**16-16. P MAINTENANCE - TURRET WEAPONS SUBSYSTEM M28A3.**

Refer to TM 9-1090-203 series manuals for additional information and maintenance procedures. Refer to paragraph 9-414 in this manual for airframe armament system circuitry information and airframe electrical component maintenance procedures. Refer to paragraph F-6 for airframe armament electrical equipment list, and paragraph F-9 for subsystem airframe wiring diagrams.

**16-17. E M DESCRIPTION DESCRIPTION - TURRET WEAPON SUBSYSTEM M97E1.**

The turret weapon subsystem M97E1 provides high performance capability to sight, position, feed, and fire the M197 20mm automatic gun. The subsystem consists of a pilot control panel, gunner control panel, turret assembly, 20mm automatic gun, 20mm ammunition feed system and electronic components. Sighting is accomplished using the **M** pilots reflex sight or the **M** Head Up Display. All necessary electrical disconnects are installed forward of the ammunition compartment, two on each side of the turret. The turret weapon subsystem interfaces with the M136 helmet sight subsystem (HSS) and the stabilized telescopic sight unit (TSU) of the M65TOW missile subsystem for sight functions.

**16-18. E M MAINTENANCE MAINTENANCE - TURRET WEAPON SUBSYSTEM M97E1.**

Removal and installation instructions for the turret assembly are given below. Refer to TM 9-1090-206 series manuals for additional information and maintenance procedures. Refer to paragraph 9-444 in this manual for airframe armament system circuitry information and airframe component maintenance procedures. Refer to paragraph F-6 for airframe armament electrical equipment list, and paragraph F-9 for subsystem airframe wiring diagrams.

**16-18.1 MILES/AGES - INSTALLATION, MAINTENANCE, AND REPAIR OF MILES/AGES.**

Refer to TM 9-1270-223-20.

**16-19. q q REMOVAL - TURRET ASSEMBLY.**

**Premaintenance Requirements for Maintenance of Turret Assembly**

Conditions	Requirements
Model	AH-1E, F,& P
Part No. or Serial No.	All
Special Tools	T65, T71
Test Equipment	None
Support Equipment	None
Minimum Personnel Required	Two
Consumable Materials	Chalk
Special Environmental Conditions	None



**WARNING**

To prevent injury to personnel, ensure that all weapon systems are unloaded and all armament circuit breakers are OFF or out before starting any maintenance procedures.

**a. Preparation for Maintenance.**

(1) Disconnect helicopter battery.

(2) Ensure that no external electrical or hydraulic power is applied to helicopter.

(3) Ensure that gun, feeder, gun drive, and recoil attenuation system have been removed from turret.

**WARNING**

Do not attempt to remove the turret unless the gun, feeder, gun drive, and recoil attenuation system have been previously removed from the turret.

**b. Removal Procedures.**

(1) Remove left and right panels (1, figure 16-1) above turret fairings from helicopter.

(2) Remove left and right fairings (2) above turret from helicopter.

(3) Open left and right ammo bay doors (3).

(4) Disconnect and cap connector W4P2 (7) from helicopter.

(5) Disconnect and cap connectors W1P3 (5) and W3P1 (4) from turret.

(6) Disconnect and cap connectors W1P16 (6) and W1P15 (8).

(7) Disconnect and cap connectors W1P22 (9), W1P7 (10) and W1P5 (11).

(8) Remove two screws (12) and washers (13) securing stow switch/azimuth tachometer bracket (14) to azimuth drive (15).

(9) Remove bolt (26) and washer (25) securing clamp (23) to bottom of azimuth resolver (22) and remove clamp (23).

(10) Remove remaining four bolts (26) and washers (25) on bottom of azimuth resolver (22) and remove bottom cover (24).

(11) Reinstall all mounting hardware for storage.

**CAUTION**

Do not rotate turret after installing allen wrench or tie wrap in resolver gear tension hole.

(12) Rotate turret by hand as necessary to install a 3/32-inch allen wrench or plastic tie wrap in resolver gear tension hole (27). Tape wrench or tie wrap in place.

(13) Using a piece of chalk, place an alignment mark (30) on the resolver gear (28) and azimuth ring gear (29) where the two gears mesh.

(14) Remove four bolts (21) and washers (20) and remove azimuth resolver (22). Reinstall bolts and washers for storage. Tape two shims (19) in place on turret.

(15) Loosen four azimuth drive mounting bolts (18) as required to obtain clearance for removal of turret.

**WARNING**

Before proceeding, ensure that four turret mounting bolts (31) are installed and secure.

(16) Remove twelve turret mounting nuts (39), four bolts (36), four washers (37), eight bolts (40) and aluminum washers (38).

(17) Place turret handling adapter (T65) in position under turret using lift truck (T71).

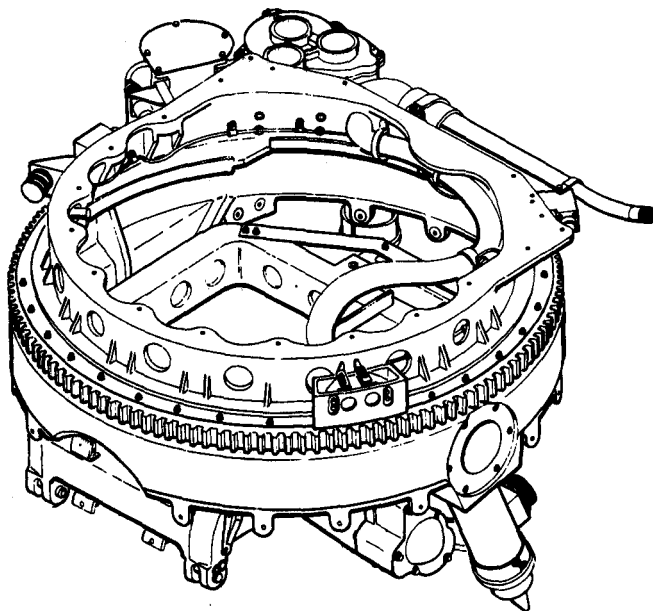
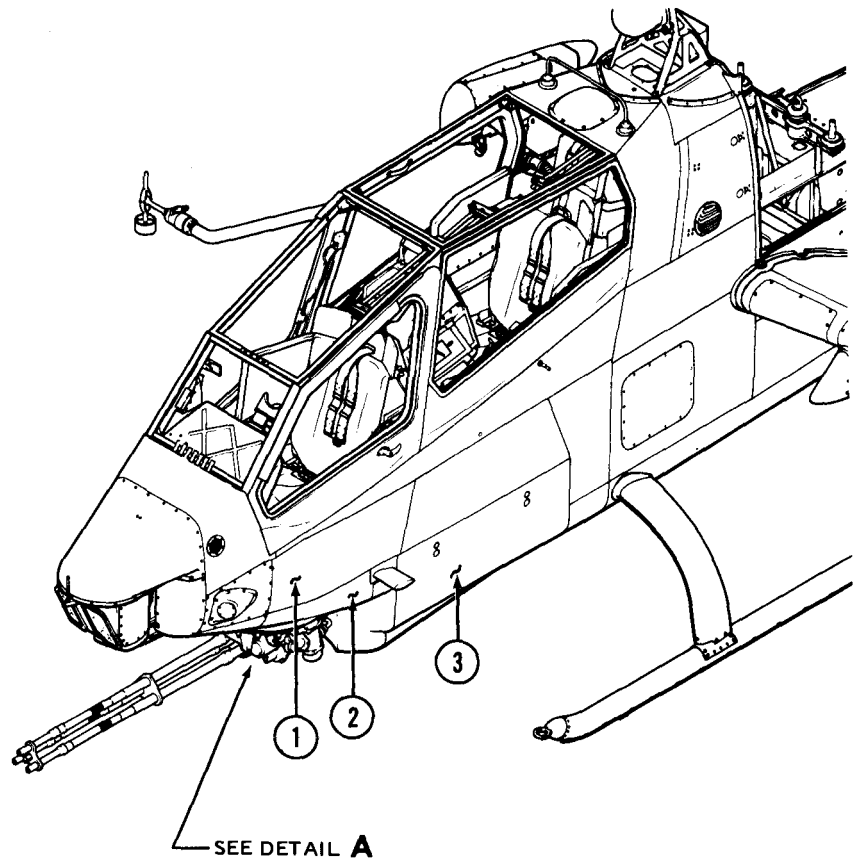

TURRET  
(SEE DETAIL B)

- 1. Left panel  
Right panel (opp)
- 2. Turret left fairing assembly  
Turret right fairing assembly (opp)
- 3. Left ammo bay door  
Right ammo bay door (opp)

209071-443-1

Figure 16-1. **E M** Turret Installation (Sheet 1 of 4)



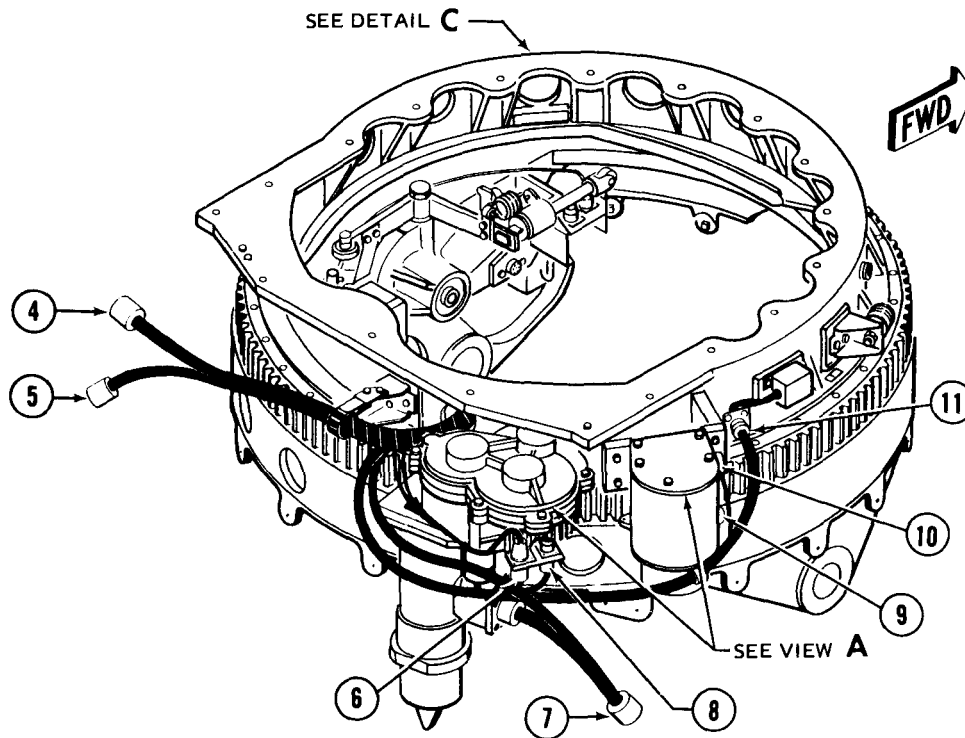

- 4. Connector W3P1 (mates with helicopter J1)
- 5. Connector W1P3 (mates with helicopter J3)
- 6. Connector W1P16 (mates with azimuth limit switch A7J13)
- 7. Connector W4P2 (mates with helicopter J2)
- 8. Connector W1P15 (mates with azimuth tachometer A7J12)
- 9. Connector W1P22 (mates with azimuth stow switch A7J23)
- 10. Connector W1P7 (mates with azimuth resolver A7J4)
- 11. Connector W1P5 (mates with azimuth buffer amplifier A7J2)

DETAIL B (Rotated 180°)

209071-443-2

Figure 16-1. **E M** Turret Installation (Sheet 2 of 4)

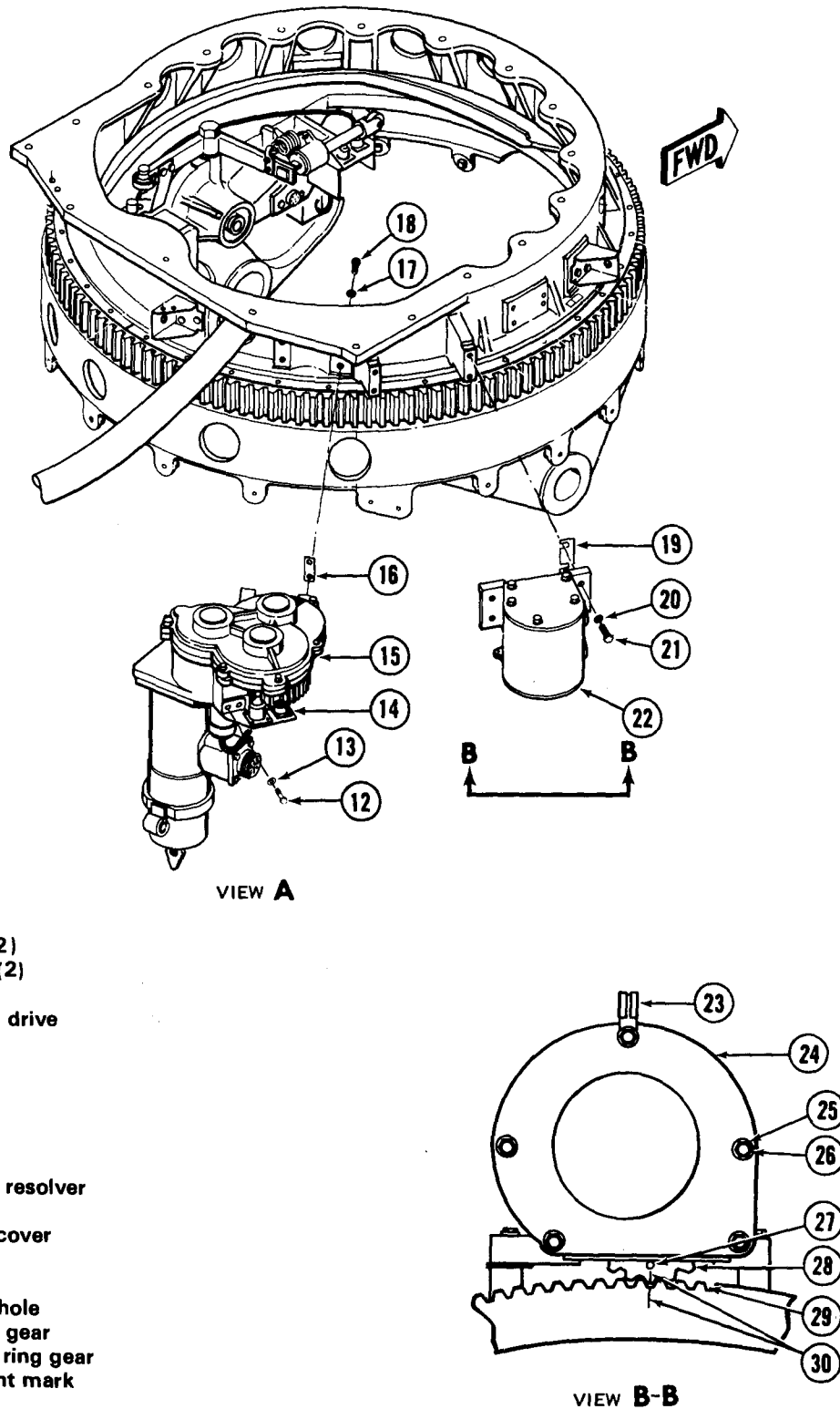

- 12. Screw (2)
- 13. Washer (2)
- 14. Bracket
- 15. Azimuth drive
- 16. Shim
- 17. Washer
- 18. Bolt
- 19. Shim
- 20. Washer
- 21. Bolt
- 22. Azimuth resolver
- 23. Clamp
- 24. Bottom cover
- 25. Washer
- 26. Bolt
- 27. Tension hole
- 28. Resolver gear
- 29. Azimuth ring gear
- 30. Alignment mark

209071-443-3

Figure 16-1. **E M** Turret Installation (Sheet 3 of 4)

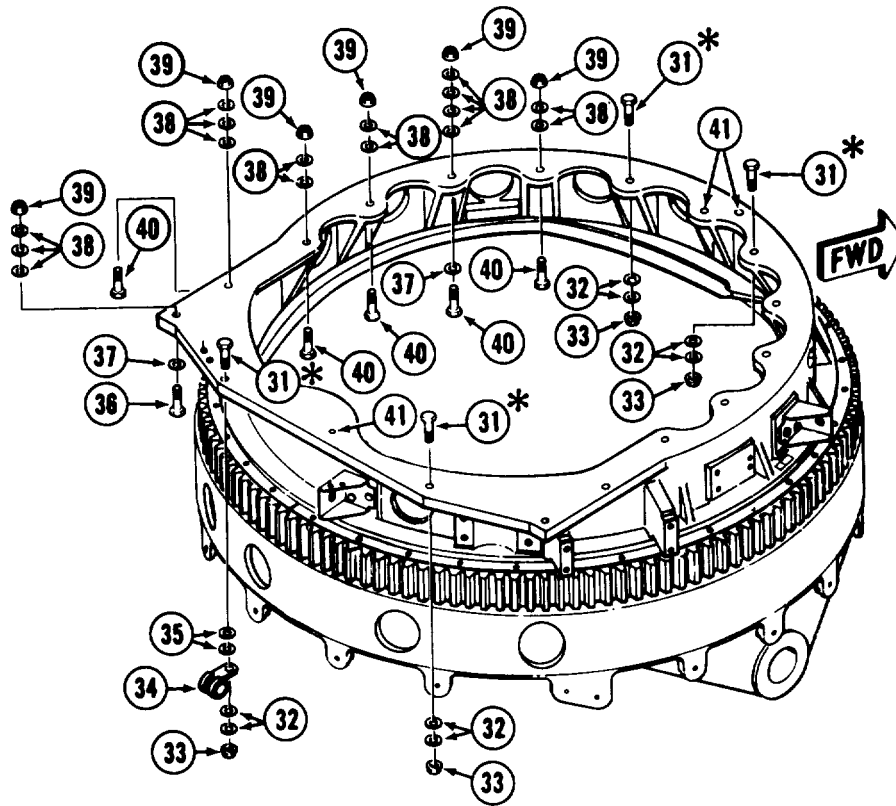

DETAIL C

- |                                 |                                 |
|---------------------------------|---------------------------------|
| 31. Bolt                        | 37. Washer                      |
| 32. Aluminum washers (see note) | 38. Aluminum washers (see note) |
| 33. Nut                         | 39. Nut                         |
| 34. Clamp assembly              | 40. Bolt                        |
| 35. Aluminum washers            | 41. Locating pin hole           |
| 36. Bolt                        |                                 |

**\*WARNING**

Before proceeding, ensure that four turret mounting bolts (31) are installed and secure. These four bolts are not to be removed until tool (T65) is installed.

**NOTE**

Number of aluminum washers shown is typical; utilize number required to obtain proper thread engagement with nuts.

209071-443-4

Figure 16-1.. **E M** Turret Installation (Sheet 4 of 4)

**WARNING**

The turret weighs approximately 200 pounds. Exercise care when performing following step to prevent injury to personnel and avoid damage to turret and/or helicopter components. Personnel should be positioned on all sides of turret to watch for any possible interference or damage as turret is being lowered and removed from helicopter.

(18) While supporting turret with turret handling adapter (T65) and lift truck (T71), remove last four mounting nuts (33), four bolts (31), aluminum washers (32), damp assembly (34) and two aluminum washers (35). Access to forward bolts is through gunner cockpit, and access to aft bolts is through access hole in forward panel of ammo box compartment.

(19) Lower and remove turret from helicopter.

**16-20.   INSTALLATION — TURRET ASSEMBLY.**

a. Preparation for Maintenance.

- (1) Disconnect helicopter battery.
- (2) Ensure that no external electrical or hydraulic power is applied to helicopter.

**NOTE**

If installed on turret, remove azimuth resolver in accordance with instructions contained in paragraph 16-16.

b. Installation Procedures.

- (1) If installed, remove left and right fairings (1, figure 16-1) above turret from helicopter.
- (2) Open left and right ammo bay doors (3).

**WARNING**

The turret weighs approximately 200 pounds. Exercise care when performing following step to prevent injury to personnel and avoid damage to turret and/or helicopter components. Personnel should be positioned on all sides of turret to watch for any possible interference or damage as turret is being raised and installed in helicopter.

**NOTE**

Coat all common hardware on turret with MIL-C-16173 (C43.1), and all electrical connectors with MIL-C-85054 (C44.2) IAW TM 1-1500-344-23.

(3) Install turret on turret handling adapter (T65).

(4) Using lift truck (T71) place turret in position under helicopter.

(5) Align fore and aft locating pin holes (41) in turret with corresponding helicopter positioning pins and carefully rake turret into position on helicopter.

**CAUTION**

Failure to install mounting hardware as specified in following steps will result in damage to equipment.

(6) Install four turret mounting bolts (31), two aluminum washers (35), damp assembly (34) and number of aluminum washers (32) required to obtain proper thread engagement with four nuts (33). Torque nuts 150 TO 190 inch-pounds.

(7) Move turret handling adapter (T65) and lift truck (T71) away from helicopter.

(8) Install four washers (37), four bolts (36), eight bolts (40) and number of aluminum washers (38) required to obtain proper thread engagement with twelve nuts (39). Torque nuts 150 TO 190 inch-pounds.

(9) Secure azimuth drive (15) in position by tightening four bolts (18).

(10) Remove tape from two azimuth resolver shims (19).

(11) Place azimuth resolver (22) in position on turret with alignment marks (30) on resolver gear (28) and azimuth ring gear (29) aligned, and secure with four washers (20) and bolts (21).

(12) Remove allen wrench or plastic tie wrap from resolver gear tension hole (27).

(13) Install damp (23) on bottom of azimuth resolver (22) with washer (25) and bolt (26).

(14) Place stow switch/azimuth tachometer bracket (14) in position on azimuth drive (15) and secure with two washers (13) and screws (12).

(15) Connect connector W1P22 (9) to A7J23, connector W1P7 (10) to A7J4 and connector W1P5 (11) to A7J2 (all on turret).

(16) Connect connectors W1P16 (6) to A7J13 and W1P15 (8) to A7J12 (all on turret).

(17) Connect connectors W1P3 (5) to helicopter J3 and W3P1 (4) to helicopter J1.

(18) Connect connector W4P2 (7) to helicopter J2.

(19) Perform turret system checkout in accordance with applicable TM 9-1090-206 series manual.

(20) Boresight turret system in accordance with applicable TM 9-1090-206 series manual.

(21) Install cover (24) on bottom of azimuth resolver (under clamp) and secure with five washers (25) and bolts (26). Use longest bolt to attach clamp.

(22) Close and secure left and right ammo bay doors (3).

(23) Install left and right fairings (2) above turret on helicopter.

(24) Install left and right panels (1) above turret fairings.

(25) Connect helicopter battery.

## 16-21. TOW MISSILE SUBSYSTEM.

### 16-22. DESCRIPTION - TOW MISSILE SUBSYSTEM.

The TOW Missile subsystem M65 is utilized as a heavy anti-tank/assault weapon. The system utilizes an optical means of tracking a target and guiding a TOW missile to the target. The system consists of a sight hand control (SHC), telescopic sight unit (TSU), **P E** pilot steering indicator (PSI), **M** Head Up Display (HUD), TOW control panel (TCP), electronic components, and TOW missile launchers. Electrical harnesses connect the electronic units together. One or two TOW missile launchers can be mounted on

each outboard wing stores pylon. Each TOW missile launcher carries two TOW missiles.

### 16-23. MAINTENANCE - TOW MISSILE SUBSYSTEM.

Refer to TM 9-1425-473 series manuals for additional information and maintenance procedures. Refer to paragraph **P** 9-427 or **E** 9-464 **M** 9-524 in this manual for airframe armament system circuitry information and maintenance procedures. Refer to paragraph F-6 for airframe armament electrical equipment list, and paragraph F-9 for airframe wiring diagrams.

### 16-24. WING STORES ROCKET LAUNCHER SUBSYSTEM.

### 16-25. **P** DESCRIPTION - ROCKET CONTROL SUBSYSTEM.

The rocket control subsystem utilizes 2.75 inch folding fin aerial rockets (FFAR) as a light anti-personnel/assault weapon. The subsystem consists of a pilot rocket control panel, two intervalometers (one for inboard rocket pods, one for outboard rocket pods), interconnecting electrical components, and rocket launchers (seven tube or nineteen tube). Rocket launchers can be mounted on each of the inboard and outboard wing stores pylons.

### 16-26. **P** MAINTENANCE - ROCKET CONTROL SUBSYSTEM.

Refer to TM 9-1055-460-14 for additional information and maintenance procedures. Refer to paragraph 9-439 in this manual for airframe armament system circuitry information and airframe electrical component maintenance procedures. Refer to paragraph F-6 for airframe armament electrical equipment list, and paragraph F-9 (wing stores) for subsystem airframe wiring diagrams,

### 16-27. **E M** DESCRIPTION - ROCKET MANAGEMENT SUBSYSTEM M138.

The rocket management subsystem (RMS) utilizes 2.75 inch folding fin aerial rockets (FFAR) as a light anti-personnel/assault weapon. The subsystem consists of a pilot control and display unit, four operations units (one at each wing stores station), interconnecting electrical components, and rocket launchers (M158A1, M158A1RC, or LWL-7 seven tube, and M200A1, M227, or LWL-19 nineteen tube). The RMS provides the capability to select fire zone for

firing. The zone containing the desired warhead may be selected and programmed for the rate, mode and quantity of rockets to be fired, and the range for airburst of M439 type fuse or penetration of forest canopy for M433 type fuse. Rocket launchers can be mounted on each of the inboard or outboard wing stores pylons.

#### 16-28. **F M** MAINTENANCE - ROCKET MANAGEMENT SUBSYSTEM M138.

Refer to TM 9-1270-207-13 and TM 9-1270-207-13P for additional information and maintenance procedures. Refer to paragraph **E** 9-477 or **M** 9-539 in this manual for airframe armament system circuitry information and maintenance procedures. Refer to paragraph F-6 for airframe armament electrical equipment list, and paragraph F-9 (wing stores) for subsystem airframe wiring diagrams.

#### 16-29. 7.62 MM GUN POD (M-18, M18E1).

#### 16-30. DESCRIPTION - 7.62MM GUN POD.

The wing stores 7.62mm gun pod is a self-contained unit housing a 7.62mm machine gun, its own electrical system, a battery recharging system, and a maximum of 1500 rounds of ammunition. The gun is capable of firing six second bursts at 2000 or 4000 rounds per minute. The 7.62mm gun pod can be mounted on each inboard wing stores pylon.

#### 16-31. MAINTENANCE - 7.62MM GUN POD.

Refer to TM 9-1005-257-12 manual for additional information and maintenance procedures. Refer to paragraphs **P** 9-438 **E** 9-488 **M** 9-548 for airframe armament system circuitry information and maintenance procedures. Refer to paragraph F-6 for airframe armament electrical equipment list, and paragraph F-9 (wing stores) for subsystem airframe wiring diagrams.

#### 16-32. IMPULSE CARTRIDGES.

#### 16-33. DESCRIPTION - IMPULSE CARTRIDGES.

Impulse cartridges are used as a power source to force the rack suspension hooks open and actuate a downward force on the ejector foot to eject stores

clear of the helicopter. Each ejector rack contains two cartridges that can be fired electrically by the jettison switches. Electrical firing of one cartridge automatically detonates the other cartridge.

### WARNING

To prevent injury to personnel, ensure that all weapon systems are unloaded and all armament circuit breakers are OFF or out before starting any maintenance procedures or tests.

### WARNING

Remove impulse cartridges from ejector rack breech prior to placing helicopter in a hangar, to prevent injury to personnel and damage to equipment.

Exception: Removal is not necessary when helicopter is to be stored in hangar for short-term, providing all three jettison circuit breakers **P** one on AC/ARMT circuit breaker panel and two in aft electrical compartment, or **E M** all three on AC/ARMT circuit breaker panel are open (OFF). ground safety pins installed, jettison switches are OFF, and warning signs indicate that helicopter has an armed jettison system.

#### 16-34. REMOVAL - IMPULSE CARTRIDGES.

### WARNING

Static electricity may cause inadvertent firing of ejector cartridges. Maintenance personnel should statically discharge themselves on a suitable ground prior to installation or removal of ejector cartridges.

**a. Outboard Ejector Rack Impulse Cartridges.**

Refer to paragraph 16-41 for removal procedures. (Accomplish 16-41 a. through 16-41 b. (4).)

**b. Inboard Ejector Rack Impulse Cartridges.**

Refer to paragraph 16-49 for removal procedures. (Accomplish 16-49 a through 16-49 b.

**16-35. INSPECTION - IMPULSE CARTRIDGES.**

**a. Inspect cartridges for damage and corrosion.**





b. Inspect cartridges for service life requirements (see NOTE below).

**NOTE**

A cartridge is considered unserviceable after ten insertions and removals from ejector rack. Each time a cartridge is removed, place a radial mark on the base of the cartridge with indelible ink. Monitor the service life by a record of inked markings and expiration date on cartridge case.

c. Inspect cartridges for shelf life (storage life) requirements. See NOTE below.

**NOTE**

The maximum shelf life for a cartridge is nine years from date of manufacture stamped on the cartridge. Cartridge ARD 63-1 and P7911-2 must be used within 15 months; cartridge CCU-44B must be used within 24 months from date of opening hermetically sealed shipping container. When opening a container, the service life expiration date (month and year) shall be marked on the side of the cartridge with indelible ink.

**16-36. INSTALLATION — IMPULSE CARTRIDGES.**

**WARNING**

Ensure that no external electrical power is applied to helicopter and that battery is disconnected before installing impulse cartridges.

**Premaintenance Requirements for installation of Impulse Cartridges**

Conditions	Requirements
Model	AH-1E, F&P
Part No. or Serial No.	All
Special Tools	T66
Test Equipment	T77

**Premaintenance Requirements for Installation of Impulse Cartridges**

Conditions	Requirements
Support Equipment	None
Minimum Personnel Required	One
Consumable Materials	None
Special Environmental Conditions	None

a. Using multimeter (T77), set for testing voltage, attach one lead to breech assembly and attach other lead to first one cartridge cavity firing contact, then the other. If no voltage is measured, proceed to step b. If voltage is measured, trace jettison circuitry (figure P F-28, E F-64, M F-111, wing stores wiring diagram) to locate and correct problem before proceeding.

**WARNING**

Ensure that no external electrical power is applied to helicopter and that battery is disconnected before installing impulse cartridges.

b. Visually inspect ejector rack and perform ground check, as required, to determine rack condition.

c. Install ground safety pin (1, figure 16-2).

d. Pull ejector piston out of housing to extend as far as possible.

Place a cartridge into each of two cartridge retainers (18, figure 16-3), or (9, figure 16-6) and screw into breech assembly. Torque retainers 75 TO 100 inch pounds and lockwire (C137) cartridge retainers together.

**CAUTION**

Overtorque of retainers causes damage to both cartridge and electronic firing contact.

f. Push ejector piston back into housing and seat.

**16-37. EJECTOR RACKS.**

**16-38. DESCRIPTION - EJECTOR RACKS.**

Each rack has a pair of hooks for attachment of an armament pod or other stores, and incorporates a cartridge-fired ejector device for emergency jettison of stores. The outboard ejector rack is adjustable in elevation by means of a hydraulic actuator. Each ejector rack contains two cartridges which can be fired electrically by pilot or gunner jettison switches. The ejector, when activated, automatically opens the hooks and forcibly ejects the pylon stores clear of the helicopter. During operations, stores are loaded or unloaded on the racks with a special wrench (T66) (2, figure 16-2) inserted into the HOOK MANUAL

RELEASE end turned according to arrow markings. A special ground safety pin (1, figure 16-2) must be inserted into the GROUND SAFETY PIN HOLE of each rack when the helicopter is on the ground. The rack hooks, will not open with the ground safety pins installed if the jettison mechanism is fired; however, the attached stores may be damaged by the ejector piston.

**16-39. FUNCTIONAL TEST - EJECTOR RACKS.**

Refer to paragraph **12** 9-438 or **1** 9-492 **A1** 9-552 and perform wing stores jettison circuitry test.

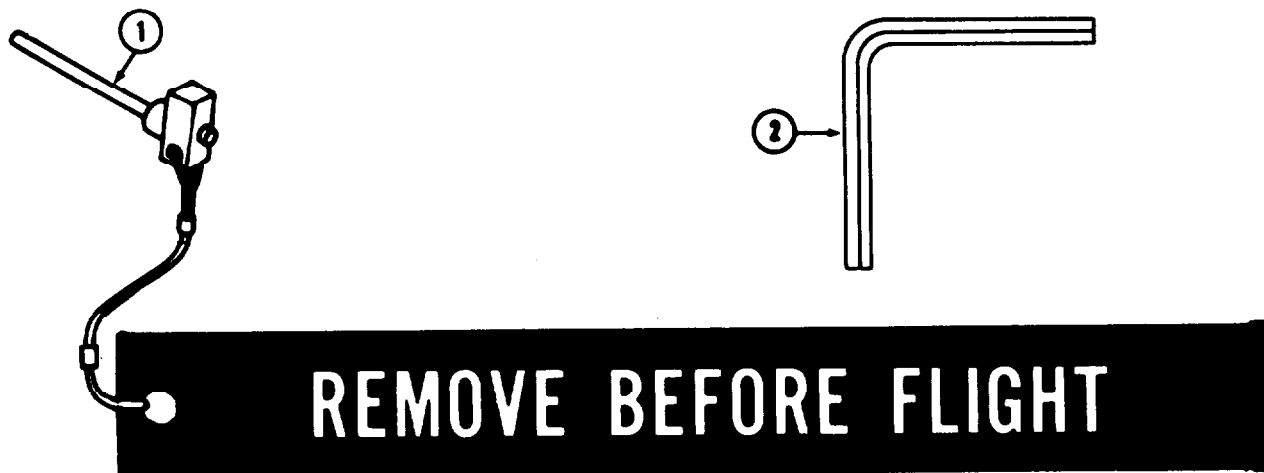

- 1. Ground safety pin
- 2. Rack release wrench

209071-361B

Figure 16-2, Special Tools For Ejector Racks

## 16-40. TROUBLESHOOTING - EJECTOR RACKS.

Refer to table **P** 16-1 or table **E M** 6-2.

### NOTE

Before using tables, ensure all normal operational checks have been performed. If a malfunction is found which is not listed in tables notify the next higher level of maintenance.

Table 16-1 **P** Troubleshooting Ejector Racks

---

#### CONDITION

TEST OR INSPECTION

#### CORRECTIVE ACTION

1. With WING STORES JTSN circuit breaker closed, the appropriate wing stores are not jettisoned when JETTISON SELECT switch is positioned to either INBD or OUTBD and pilot JETTISON switch is pressed.

STEP 1. Check for defective wiring.

**Repair wiring (figure F-28).**

STEP 2. Check for defective WING STORES JTSN circuit breaker.

**Replace circuit breaker (paragraphs 9-27 and 9-29).**

STEP 3. Check for defective pilot JETTISON switch.

**Replace switch (paragraphs 9-20 and 9-22).**

STEP 4. Check for defective JETTISON SELECT switch.

**Replace switch (paragraphs 9-20 and 9-22).**

STEP 5. Check for defective diode between terminals 3 and 4 or 5 and 6 on terminal board (ITB13).

**Replace diode (paragraphs 9-20 and 9-22).**

STEP 6. Check for defective inboard or outboard jettison select relay (21K3).

**Replace relay (paragraphs 9-20 and 9-22).**

2. The appropriate wing stores are jettisoned on one side, but not the other when JETTISON SELECT switch is positioned to either INBD or OUTBD, and pilots JETTISON switch is pressed.

STEP 1. Check for defective or improperly installed ejector rack cartridge.

**Replace cartridges and tighten retainers to specified torque (paragraph 16-41).**

Table 16-1. **F** Troubleshooting Ejector Racks (Cont)

---

CONDITION

TEST OR INSPECTION

**CORRECTIVE ACTION**

STEP 2. Check for defective wiring.

**Repair wiring (figure F-28).**

STEP 3. Check for defective wing disconnect connectors.

(21J1-21P1, 21J3-21P3) or (21J2-21P2, 21J4-21P4) on the side which does not jettison.

**Replace connector (paragraphs 9-20 and 9-22).**

STEP 4. Check for defective pilot jettison switch relay (21K3).

**Replace relay (paragraphs 9-20 and 9-22).**

STEP 5. Check for defective JETTISON or JETTISON SELECT switch.

**Replace switch (paragraphs 9-20 and 9-22).**

3. With WING STORES JTSN circuit breaker closed, wing stores are not jettisoned when gunner WING STORES JETTISON switch is positioned to up position.

STEP 1. Check for defective wiring.

**Repair wiring (figure F-28).**

STEP 2. Check for defective WING STORES JTSN circuit breaker.

**Replace circuit breaker (paragraphs 9-27 and 9-29).**

STEP 3. Check for defective gunner WING STORES JETTISON switch.

**Replace switch (paragraphs 9-20 and 9-22).**

STEP 4. Check for continuity between pins B2 and B3 of jettison control relay (21K2) when WING STORES JETTISON switch is positioned to up position. Next check for required continuity between pins 62 and B1 of relay.

**Replace relay if it fails check (paragraphs 9-20 and 9-22).**

STEP 5. Check for defective jettison control relay (21K2) (inboard only).

**Replace relay (paragraphs 9-20 and 9-22).**

STEP 6. Check for defective firing circuit in rack.

Test continuity from rack connector to firing pin using multimeter (paragraph 9-438).

**Replace rack if defective (paragraphs 16-41, 16-44, 16-49, and 16-52.)**

Table 16-1. **P**Troubleshooting Ejector Racks (Cont)

## CONDITION

## TEST OR INSPECTION

**CORRECTIVE ACTION**

4. Outboard ejector rack pylon fails to activate in elevation or depression.

STEP 1. Check that LCHR BORESIGHT SWITCH (in ammo compartment) is in proper position.

**Position switch to OFF.**

STEP 2. Defective hydraulic actuator.

**Replace hydraulic actuator (paragraph 16-43).**

STEP 3. Defective resolver.

**Replace resolver (paragraphs 16-41 a. through 16-41 b. (5) and 16-44 f. and h.**

STEP 4. Check for defective wiring between TSU and ejector rack pylon.

**Repair wiring (figure F-28.)**

5. Excessive torque required for manual release.

STEP 1. Dirty linkage in the release system.

**Clean the rack (paragraph 16-47 or 16-53).**

STEP 2. The hook pivot bolt may be damaged.

**Replace the rack (paragraphs 16-41 and 16-44 or paragraphs 16-49 and 16-52).**

STEP 3. The rack side plates may be distorted.

**Replace the rack (paragraphs 16-41 and 16-44 or paragraphs 16-49 and 16-52).**



**Adjustment of sway brace bolts may affect boresighting. Sway brace bolts must be adjusted by armament personnel.**

STEP 4. Sway brace bolts not unloaded.

**Back off sway brace bolts.**

Table 16-2. **E** **M** Troubleshooting Ejector Racks

CONDITION

TEST OR INSPECTION

**CORRECTIVE ACTION**

1. With WING STORE PLT JETT circuit breaker closed (up), the appropriate wing stores are not jettisoned when JETTISON SELECT switch is positioned to either INBD or OUTBD and pilot JETTISON switch is pressed.

STEP 1. Check for defective wiring.

**Repair wiring, Figure **E** F-64, **M** F-111.**

STEP 2. Check for defective WING STORE PLT JETT circuit breaker.

**Replace circuit breaker (paragraphs 9-27 and 9-29).**

STEP 3. Check for defective pilot JETTISON switch.

**Replace switch (paragraphs 9-20 and 9-22).**

STEP 4. Check for defective JETTISON SELECT switch.

**Replace switch (paragraphs 9-20 and 9-22).**

STEP 5. Check for defective pilot jettison switch relay (21K3).

**Replace relay (paragraphs 9-20 and 9-22),**

2. The appropriate wing stores are jettisoned on one side, but not the other when JETTISON SELECT switch is positioned to either INBD or OUTBD and pilot JETTISON switch is pressed.

STEP 1. Check for defective or improperly installed ejector rack cartridge.

**Replace cartridges and tighten retainers to specified torque (paragraph 16-41).**

STEP 2. Check for defective wiring.

**Repair wiring Figure **E** F-64, **M** F-111.**

STEP 3. Check for defective wing disconnect connectors (21J1-21P1) or (21J2-21P2) on the side which does not jettison.

**Replace connector (paragraphs 9-20 and 9-22).**

STEP 4. Check for defective pilot jettison switch relay (21K3).

**Replace relay (paragraphs 9-20 and 9-22).**

STEP 5. Check for defective JETTISON or JETTISON SELECT switch.

**Replace switch (paragraphs 9-20 and 9-22).**

Table 16-2 **E** **M** Troubleshooting Ejector Racks (Cont)

## CONDITION

TEST OR INSPECTION

## CORRECTIVE ACTION

3. With WING STORES GNR JETT circuit breaker closed (up), wing stores are not jettisoned when JTSN SEL switch is positioned to either INBD or OUTBD and gunner WING STORES JETTISON switch is positioned to up position.

STEP 1. Check for defective wiring.

**Repair wiring Figure **E** F-64 **M** F-111.**

STEP 2. Check for defective WING STORE GNR JETT circuit breaker.

**Replace circuit breaker (paragraphs 9-27 and 9-29).**

STEP 3. Check for defective gunner WING STORES JETTISON switch.

**Replace switch (paragraphs 9-20 and 9-22).**

STEP 4. Check for defective JTSN SEL switch.

**Replace switch (paragraphs 9-20 and 9-22).**

STEP 5. Check for defective jettison control relay (21K2) (inboard only).

**Replace relay (paragraphs 9-20 and 9-22).**

STEP 6. Check for defective firing circuit in rack.

**Test continuity from rack connector to firing pin using multimeter (paragraph 9-492). Replace rack if defective (paragraphs 16-41, 16-44, 16-49, and 16-52).**

4. Outboard ejector rack pylon fails to activate in elevation or depression.

STEP 1. Check that LCHR BORESIGHT SWITCH (in ammo compartment) is in proper position.

**Position switch to OFF.**

STEP 2. Defective hydraulic actuator.

**Replace hydraulic actuator (paragraph 16-43 d.)**

STEP 3. Defective resolver.

**Replace resolver (paragraphs 16 41 b(5) and 16-44 f and h.**

STEP 4. Check for defective wiring between TSU and ejector rack pylon.

**Repair wiring Figure **E** F-64 **M** F-111.**

Table 16-2 **E M** Troubleshooting Ejector Racks (Cont)

CONDITION

TEST OR INSPECTION

**CORRECTIVE ACTION**

5. Excessive torque required for manual release.

STEP 1. Dirty linkage in the release system.

**Clean the rack (paragraph 16-47 or 16-53).**

STEP 2. The hook pivot bolt is damaged.

**Replace the rack (paragraphs 16-41 and 16-44 or paragraphs 16-49 and 16-52).**

STEP 3. The rack side plate is distorted.

**Replace the rack (paragraphs 16-41 and 16-44 or paragraphs 16-49 and 16-52).**



**Adjustment of sway brace bolts may affect boresighting. Sway brace bolts must be adjusted by armament personnel.**

STEP 4. Sway brace bolts not unloaded.

**Back off sway brace bolts.**

**16-41. REMOVAL - OUTBOARD EJECTOR RACKS.**

**Premaintenance Requirements For Maintenance of Outboard Ejector Racks**

Conditions	Requirements
Model	AH-1S
Part No. or Serial No.	All
Special Tools	T13, T66, T67, T82, T83
Test Equipment	T77
Support Equipment	S2, S12
Minimum Personnel Required	One

**Premaintenance Requirements For Maintenance of Outboard Ejector Racks (Cont)**

Conditions	Requirements
Consumable Materials	C19, C37, C58, C112, C113, C137
Special Environmental Conditions	None



**To prevent injury to personnel, ensure that all weapon systems are unloaded and all armament circuit breakers are OFF or out before starting any maintenance procedures or tests.**



**WARNING**

Serious injury can result from accidental ground Jettison of outboard ejector racks.

a. Preparation for Maintenance.

(1) Disconnect battery.

(2) Position all armament circuit breakers and switches to OFF.

**WARNING**

Ensure all stores are properly supported before removing ground safety pin (1, figure 16-2).

(3) Loosen four sway brace bolts.

(4) Remove stores from rack using special rack release wrench (T66) (2, figure 16-2) for manual release.

b. Removal Procedures.

(1) Remove wing tip fakings from rack and outboard leading edge of wing.

(2) Disconnect electrical connectors from components on rack.

(3) Cut and remove lockwire from retainers (18, figure 16-3).

(4) Remove cartridge retainers (18) and cartridges from breech of ejector rack.

(5) Remove resolver and bracket (14) from outboard side of rack (21).

(6) Disconnect and remove accelerometer (17).

(7) Remove bolt (37), washers (36 and 35) nut (34), and cotter pin (33) connecting actuator (1) to sway brace assembly (22).

(8) Remove three nuts (39), three washers (38), three washers (31) and three bolts (32) connecting forward sway brace assembly (22) to forward end of rack (21).

(9) Remove three nuts (40), three washers (41), three washers (42) and three bolts (43) connecting aft sway brace assembly (10) to aft end of rack (21).

**NOTE**

Do not remove threaded shaft (5) from bolt on fitting assembly (2).

(10) Remove nut (13), washer (12) and rotter pin (11) from bolt on fitting assembly (2) and lift rack (21) outboard.

**CAUTION**

Take care not to damage threaded I haft (5) during removal and subsequent handling of fitting assembly (2).

(11) Remove fitting (2) from wing pylon.

(a) Disconnect hydraulic line from actuator (1).

(b) Remove two bolts (4) and two washers (3).

(c) Remove bolt (7) and washer (6), bolt (9), washer (8), bolt (19) and washer (20) and lift fitting (2) from wing pylon.

#### 16-42. INSPECTION — OUTBOARD EJECTOR RACKS.

a. Visually inspect hydraulic actuator (1, figure 16-3) for leakage or damage.

b. Inspect electrical cables for fraying or damaged electrical connectors.

c. Visually inspect accelerometer (17) and resolver (14) for evidence of mechanical damage, binding, or misalignment.

d. Inspect for cracks, external corrosion, and cleanliness. If rack has been used to jettison stores, perform cleaning and inspection of ejector parts. (Refer to paragraphs 16-46 and 16-47).

e. Inspect forward and aft sway brace assemblies.

(1) The clearance between the groove on the fitting assembly (2) and the tongue of the sway braces (10 or 22) must not exceed 0.020 inch. Remove fairings and disconnect servo actuator from fitting (2), and then move fitting (2) full up or full down. The clearances can be obtained by using a feeler gauge with all the components installed on the aircraft or by measuring the differences between the tongues and the grooves.

(2) If there is a high level of vibration transmitted into the aircraft due to excessive clearance, the sway braces will be replaced.

#### 16-43. REPAIR – OUTBOARD EJECTOR RACKS.

a. Replace any cracked, damaged or unserviceable hydraulic fittings or flexible lines.

b. Replace fakings if unserviceable.

c. Remove external superficial corrosion from rack by using crocus cloth (C37) or phosphoric solution (C19).

d. Replace rack hydraulic actuator (1, figure 16-3), if unserviceable.

(1) Dined electrical connectors to actuator (1).

(2) Remove hydraulic lines from actuator (1).

(3) Cap open hydraulic lines.

(4) Remove hydraulic fittings from inlet and outlet ports of actuator (1). Retain fittings for reinstallation.

(5) Cap inlet and outlet ports of actuator (1).

(6) Remove cotter pin (33), nut (34), washers (35 and 36), and bolt (37), securing lower end of actuator (1) to forward sway brace assembly (22).

(7) **P** Remove screw (30), washer (29), and spacer (27) from bracket (38) and actuator (1).

(6) Remove cotter pin (26), nut (25), washer (24), and bolt (23), securing upper end of actuator (1) to fitting assembly (2).

(9) Remove actuator (1) from helicopter.

#### NOTE

Rack hydraulic actuator is factory adjusted for proper length. Adjustment of actuator will be accomplished during final adjustment and boresighting of system.

(10) Remove caps (if installed) from inlet and outlet pods of actuator (1).

(11) Install hydraulic fittings in inlet and outlet ports of actuator (1).

(12) Position actuator (1) on fitting assembly (2) and forward sway brace assembly (22).

(13) In upper end of actuator (1), install bolt (23), washer (24), and nut (25). Torque nut (25) to 5 inch-pounds and install cotter pin (26).

(14) **P** Install spacer (27), washer (29), and screw (30) on bracket (28) and actuator (1) as shown in view A.

(15) Install bolt (37), washers (36 and 35), nut (34), and cotter pin (33) in lower end of actuator(1).

(16) Install hydraulic lines on fittings of actuator (1).

(17) Connect electrical connectors to actuator.

(18) Bleed hydraulic system.

(a) **P** paragraph 7-3.

(b) **E M** paragraph 7-143.

(19) Perform alignment test (paragraph 16-45).

#### 16-44. INSTALLATION — OUTBOARD EJECTOR RACKS.

#### NOTE

Coat all common hardware on outboard ejector rack with MIL-C-16173 (C43.1) and all electrical connectors with MIL-C-85054 (C44.3) IAW TM 1-1500-344-23.

a. Install fitting (2, figure 16-3) on end of wing.

(1) Position fitting (2) on wing pylon and connect hydraulic lines to actuator (12).

(2) Install two bolts (4) and two washers (3). Install washers with countersink toward head of bolt. Torque bolts 300 TO 333 inch-pounds. Lockwire (C137) bolts.

**(3)** Install bolt (19) and washer (20). Install washer with countersink toward head of bolt. Torque bolt **120 TO 160** inch-pounds. Lockwire (C137) bolt.

**(4)** Install bolt (7) and washer (6). Install washer with countersink toward head of bolt. Torque bolt 75 TO 95 inch-pounds. Lockwire (C137) bolt.

**(5)** Install bolt (9) and washer (8). Install washer with countersink toward head of bolt. Torque bolt **468-516** inch-pounds. Lockwire (C137) bolt.

**b.** Install rack (21) on bolt of fitting (2), and install washer (12) and nut (13). Torque nut **5 TO 50** inch-pounds and install cotter pin (11).

**c.** Install sway forward brace assembly (22) on end of rack (21) with three bolts (32), three washers (31), three washers (38) and three nuts (39). Install washers with countersink side toward bolt head. Torque nuts **120 TO 160** inch-pounds.



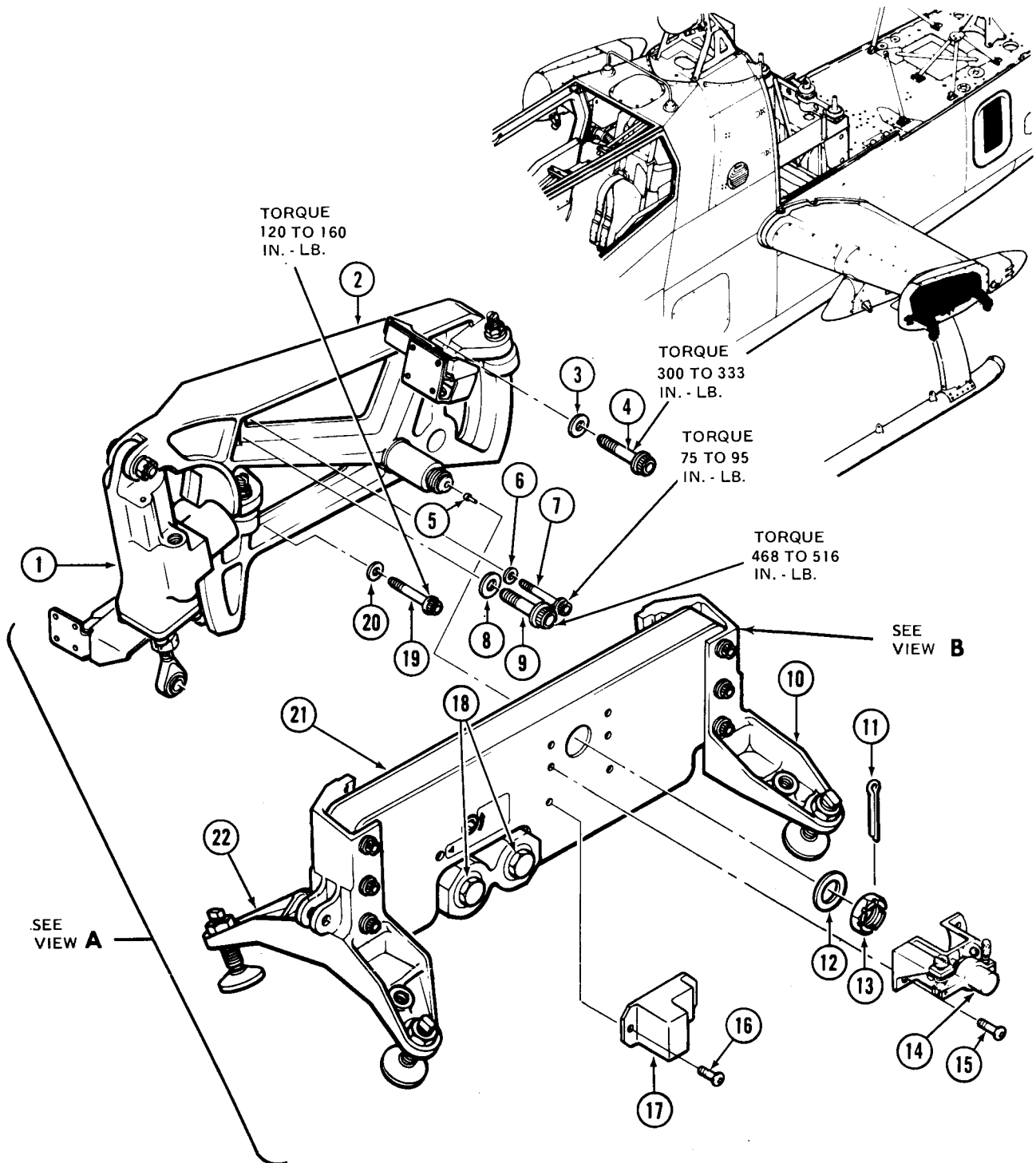

209071-362-10

Figure 16-3. Outboard Ejector Rack Installation (Sheet 1 of 2)

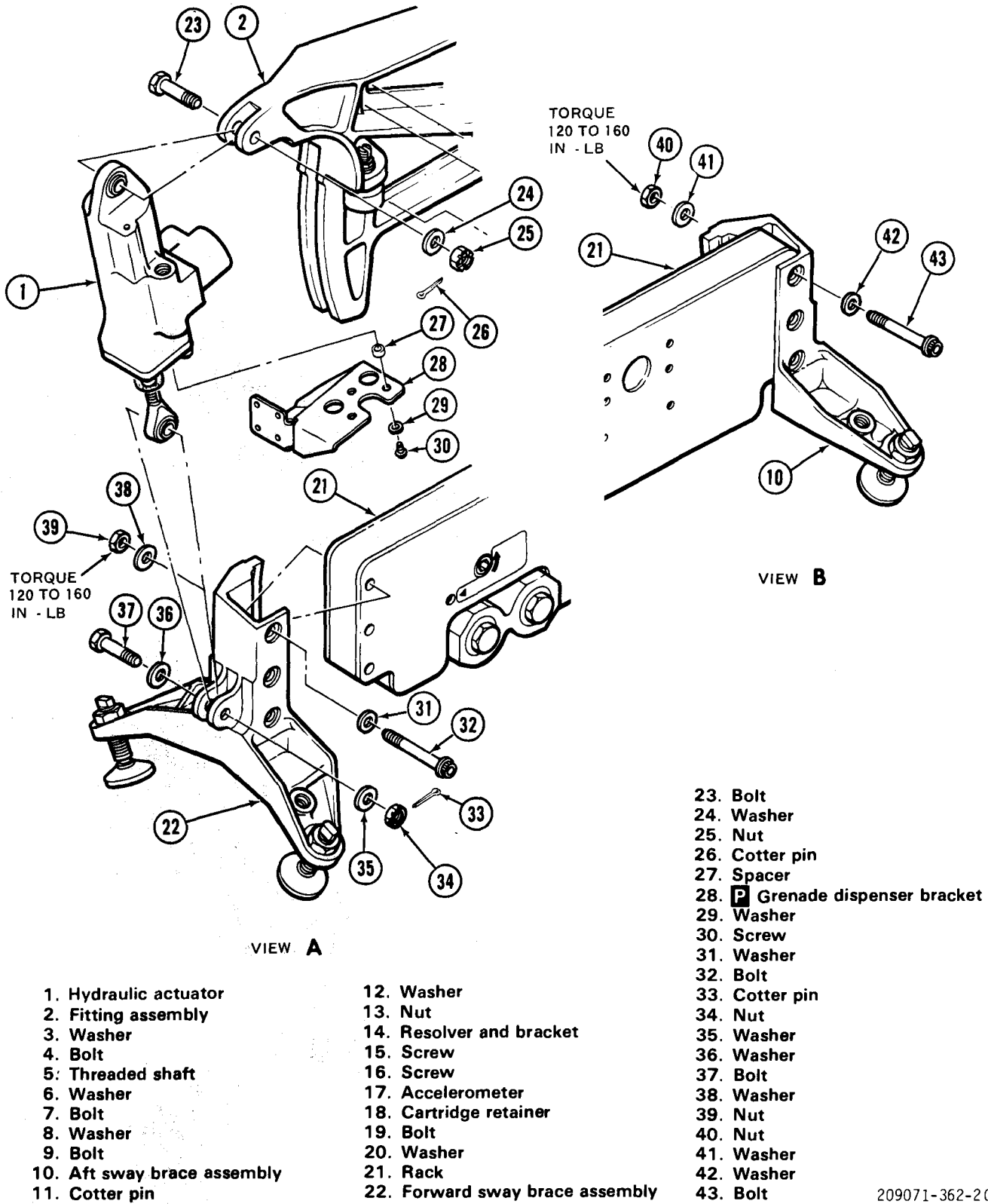

209071-362-2C

Figure 16-3. Outboard Ejector Rack Installation (Sheet 2 of 2)

**d.** Install aft sway brace assembly (10) on end of rack (21) in same manner. Install washers with countersink side toward bolt head. Torque nuts **120 TO 160** inch-pounds.

**e.** Connect actuator (1) to forward sway brace (22) with bolt (37) washers (36 and 35) and nut (34). Torque nut (34) to 5 inch-pounds and install cotter pin (33),

**f.** Install resolver and bracker (14) with four screws (15).

**g.** Install accelerometer (17) with two screws (16).

**h.** Connect ail electrical connectors.

**WARNING**

**Do not install ejector cartridges in the ejector rack prior to alignment.**

**i.** Perform alignment test (paragraph 16-45).

**16-45. ALIGNMENT TEST - OUTBOARD EJECTOR RACKS.**

The alignment test consists of adjusting the mechanical stops, pylon actuator and pylon resolvers.

**a. Test Preparations.**

Remove TSU nose fairing and outboard portions of outboard pylon fairings.

**b. Elastomeric Stop Adjustment.**

The following procedure is used to set the mechanical stops to allow a total of **12** degrees of ejector rack travel:

**(1)** Install TSU boresight device (T83) on pitch and roll pads of TSU.

**(2)** Loosen sway brace pads and install ejector rack alignment fixture (T82) on ejector rack hooks. Finger tighten sway brace pads.

**(3)** Disconnect hydraulic actuator (1, figure 16-4) from sway brace assembly (7) by removing bolt (8) from rod end of actuator.

**(4)** Position hydraulic actuator (1) so that ejector rack assembly (6) can be manually rotated without interference with actuator.

**(5)** Place gunner quadrant (T13) on TSU boresight device, level the bubble, and record the angle. (Note the nose-up or nose-down attitude.)

**(6)** Transfer gunner quadrant to ejector rack alignment fixture.

**(7)** Manually rotate ejector rack assembly (6) toward a nose-up attitude. Adjust forward mechanical stop (3) until the maximum pitch-up attitude of ejector rack assembly is **124.4 TO 128.8** mils (7 degrees to 7 degrees, 15 minutes) greater than the angle recorded on TSU boresight device (step (5) and figure 16-4). Tighten forward locknut (2).

**(8)** Manually rotate ejector rack assembly (6) toward a nose-down attitude Adjust aft mechanical stop (5) until the maximum pitch-down attitude of ejector rack assembly is **88.9 to 93.3** mils (**5** degrees to **5** degrees, **15** minutes) less than the angle recorded on TSU boresight device (step (5) and figure 16-4). Tighten aft locknut (4).

**(9)** Manually rotate ejector rack assembly toward a nose-up attitude. Adjust hydraulic actuator rod end until the nose-up attitude of the ejector rack is **71.1 (± 8.9)** mils (**4 ± (0.5)** degrees) greater than the angle recorded on TSU boresight device (step (5) and figure 16-4).

**NOTE**

**One complete turn of hydraulic actuator rod end equals approximately 4 mils (0.25 degrees) elevation of the ejector rack.**

**(10)** Reconnect hydraulic actuator (1) to sway brace assembly (7).

**(11)** Transfer ejector rack alignment fixture (T82) to the opposite pylon and repeat steps (2) through (10).

**c. Control Switch Positions.**

Position following switches as indicated:

**(1) Pilot Armament Control Panel:**

MASTER ARM	OFF
WPN COUNT	GUNNER

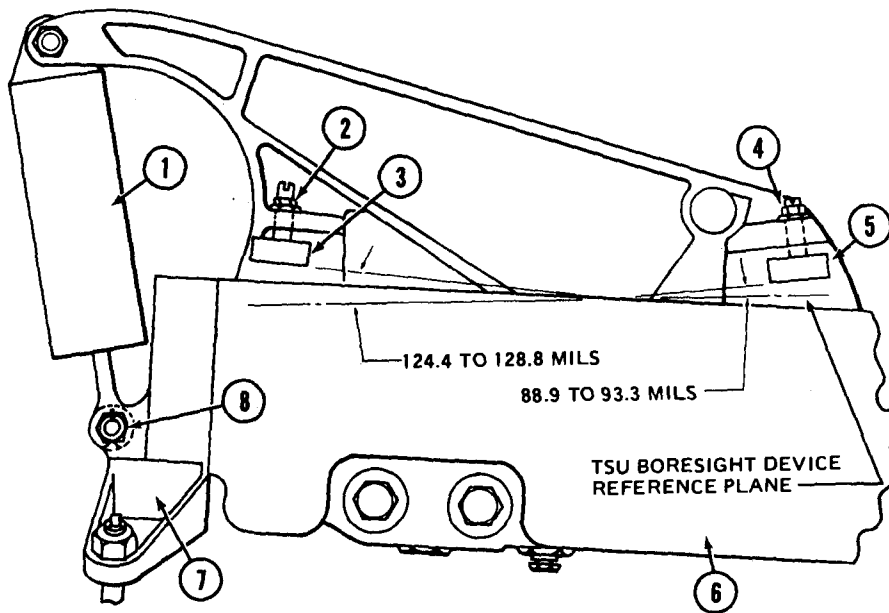

- 1. Hydraulic actuator
- 2. Forward lock nut
- 3. Forward mechanical bumper stop
- 4. Aft lock nut
- 5. Aft mechanical bumper stop
- 6. Ejector rack assembly
- 7. Sway brace assembly
- 8. Bolt and nut

Figure 16-4. Ejector Rack Alignment

**(2) Electrical Power.**

Check that helicopter battery is connected, then apply 28 Vdc power from electrical auxiliary power unit (S12).

**(3) Circuit Breakers.**

Engage the following circuit breakers:

(a) **P**

AC/ARMT  
CB PANEL

DC CB PANEL

WPN CONT  
WPN FIRE  
TURRET CONT  
REF XFMR  
TOW PWR

CAUT LT  
PLT INSTR LT  
DC VM  
INV MAIN

AC/ARMT  
CB PANEL

DC CB PANEL

28 VAC XFMR  
SECU

INV STBY  
EM HD PWR

(b) **E M**

AC/ARMT  
CB PANEL

DC CB PANEL

WPN CONTR  
WPN FIRE  
**E** TURRET CONTR  
**M** ARMT CONTR  
REF XFMR  
TMS PWR  
28 VAC XFMR  
SECU PWR

CAUT LT  
PLT INST LT

DC VM  
INV  
EMER HYD PUMP

(c) **E M**

AFT ELEC CMPT  
AC CB PANEL

TOW PWR  
TSGMS PWR  
BATT RLV  
ESNTL BUS



**(4) Power Switch Positions.**

Position the following switches as shown:

**(a) P**

INV	MAIN
BAT	OFF
NON-ESNTL BUS	MANUAL
ELECT PWR/EMER OFF	ELEC PWR

**(b) E M**

BATTERY	RUN
NON-ESNTL BUS	MANUAL
ELEC PWR/EMER OFF	ELEC PWR
MASTER ARM	STBY

**(5) Hydraulic Power.**

Place pilot (or gunner) EMER HYDR PUMP switch to BORESIGHT position. (This applies limited hydraulic power to **P**urret and outboard pylon.)

**d. Alignment Procedures.**

(1) Turn MODE SELECT switch on the TCP to ARMED MAN.

(2) Position Hi/LO MAG switch on left hand grip (LHG) to HI and verify that ACQ/TRK/STOW switch on sight hand control (SHC) is in the STOW position.

(3) Install ejector rack alignment fixture (T82) on ejector rack hooks.

(4) Activate left or right launcher with LCHR BORESIGHT switch, located in left ammo bay on the aft wall.



**Before turning pilot MASTER ARM switch to ARM position, keep hands clear of articulating outboard ejector rack assembly. Racks may move rapidly up or down.**

(5) Position MASTER ARM switch to ARM.

(6) Loosen four setscrews on ejector rack resolver mount assembly.

(7) Place gunner quadrant (T13) on TSU boresight device, level the bubble, and record pitch angle. (Note the nose-up or nose-down attitude.)

(8) Transfer gunner quadrant to ejector rack alignment fixture, maintaining same fore and aft orientation as measured on TSU boresight device.

(9) Adjust fine adjustment screw on resolver mount assembly until the angle of ejector rack alignment fixture is 17.8 mils ±1.78 mils (1 ±0.1) degrees greater than the angle recorded on TSU boresight device.

**NOTE**

**If proper adjustment is achieved, proceed to step (12). If proper adjustment cannot be achieved, return fine adjustment screw to the mid position and proceed to steps (10) and (11).**

(10) Loosen resolver coarse adjustment screw and rotate body of resolver until approximate desired angle is achieved.

**NOTE**

**If pylon will not stop at approximate desired angle, resolver may be out-of-phase. Rotate resolver 180 degrees and repeat step (10).**

(11) Tighten resolver coarse adjustment screw and repeat step (9).

(12) Tighten four setscrews on resolver mount assembly.

(13) Check that the 17.8 mil difference did not change after tightening setscrews.

(14) Deactivate and activate the LCHR bore-sight switch several times to ensure rack will stow and lock.

**NOTE**

**If rack will not lock in the stow position, determine which direction to adjust the hydraulic actuator rod end to ensure proper locking. (e.g., If downward pressure on aft end of rack alignment fixture will cause actuator to lock; the actuator rod end should be extended until the stowing mode will lock the rack.)**

(15) Transfer ejector rack alignment fixture to opposite ejector rack hooks and repeat steps (4) through (13).

**WARNING**

Do not install cartridges in ejector racks prior to continuity test.

e. Using multimeter (T77), perform electrical continuity test of wing stores jettison circuits (paragraph P: 9-438 E: 9-492 or M: 9-552).

**NOTE**

Adjust ejector foot pad (18, figure 16-5) to snugly fit the specific armament weapon installed.

f. Install cartridges in breech assembly (paragraph 16-36).

**16-46. DISASSEMBLY FOR CLEANING AFTER JETTISON - OUTBOARD EJECTOR RACKS.**

As soon as possible after ejector rack has been used to jettison stores, perform cleaning procedure as follows:

a. Remove outboard ejector rack (paragraph 16-41).

**WARNING**

To prevent injury to personnel, ensure that all weapon systems are unloaded and all armament circuit breakers are OFF or out before starting any maintenance procedures.

To prevent injury to personnel, make certain no live cartridges are installed in the breech prior to disassembly.

b. Remove two cartridge retainers (16, figure 16-5) to ensure no live cartridges are installed. Remove and discard any fired cartridges. Dispose of live cartridges in accordance with prescribed ordnance procedures,

**CAUTION**

When sideplate is removed from remainder of ejector rack, shackies and linkage will fall out if remaining assembly is inverted. During disassembly, remove required screws from right (bottom) sideplate first so that rotation will not be required after left sideplate is loosened.

c. Remove three screws (33) from right sideplate (13) (two from aft closeout and one in cylinder cap).

d. Cut lockwire and remove retainer (26) with piston (21) and spring (19) from breech.

e. Pull piston (21) out of retainer (26), then remove and discard packings (20, 28 and 29).

f. Remove ejection cylinder (7), ejection piston (5), foot (18) and packing (17) from breech as an assembly.

g. Unscrew foot (18) from ejection piston (5) and push ejection piston (5) up out of ejection cylinder (7). Remove and discard packing (17) from inside lower end of ejection cylinder (7).

h. Remove nut (31), two washers (30 and 2) and bolt (1); then place ejector rack on a clean workbench with the left sideplate (24) up for remainder of disassembly.

i. Remove nut (23), washer (22) and screw (25) from forward end of breech and left sideplate (24).

j. Remove four screws (27) securing left sideplate (24) to four spacers (14).

k. Remove four screws (32) securing left sideplate (24) to mounting column.

l. Remove four screws (34) securing left sideplate (24) to two bumper pads and forward closeout, then remove remaining screw (23) from cylinder cap (8).

m. Carefully lift sideplate (24) off remainder of assembly, tapping sideplate at openings where linkage, shackles, and spring retainers fit into bushings. Ensure that left sideplate (24) separates

from shackles and linkage trunnions that must remain seated in right sideplate (13).

**n.** Move cylinder cap (8) out slightly away from right sideplate (13) to clear pin from bushing and lift cylinder cap (8) off gas tube (4). Remove and discard packing (6) from inside cylinder cap (8).

**o.** Pull gas tube (4) out of breech; then remove and discard two packings (3).

**p.** Clamp cylinder cap (8) in a vise that has padded jaws. Cut lockwire and remove orifice holder (9) from cylinder cap (8). Remove and discard packings (10 and 11) and backup ring (12)



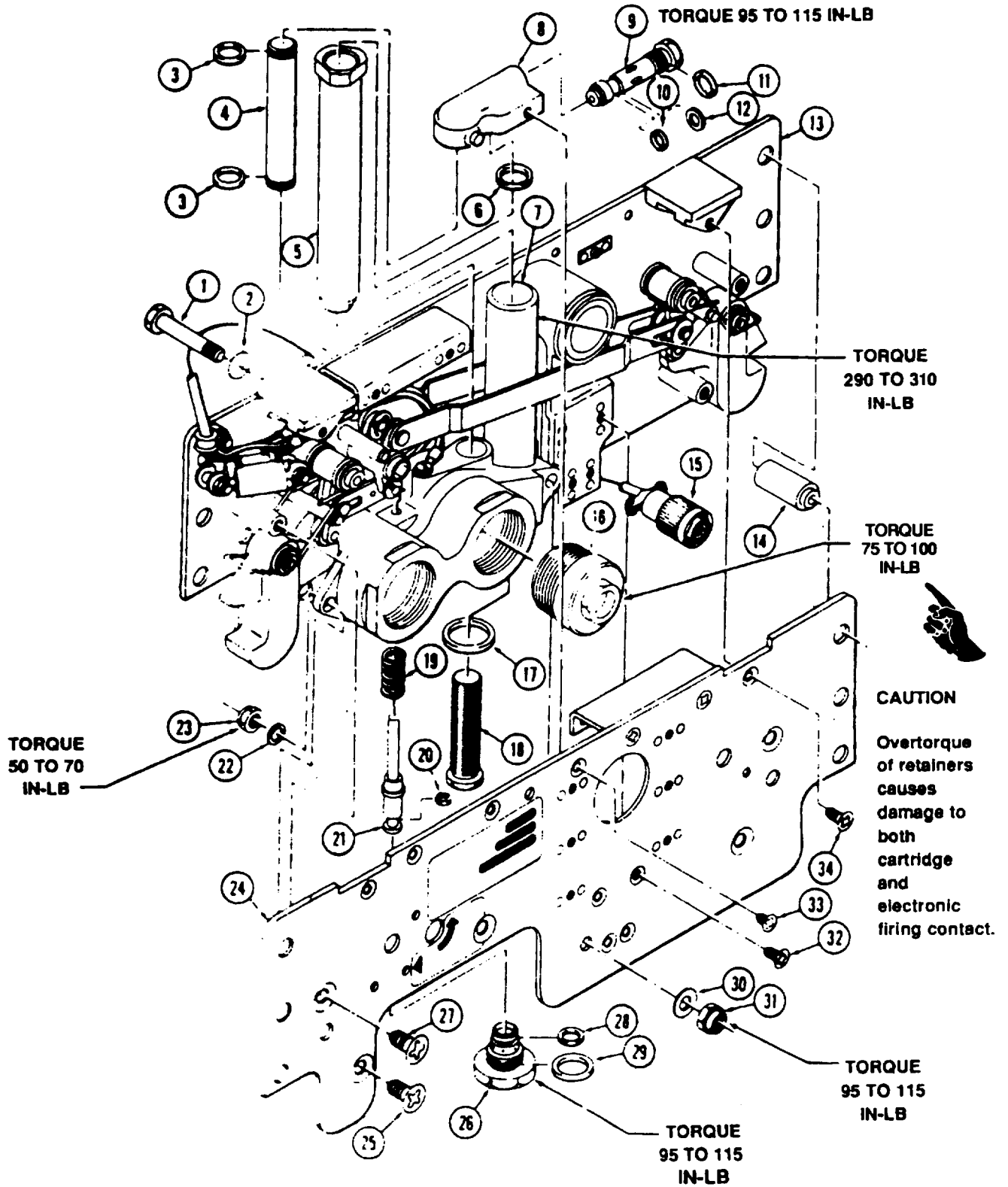

Figure 16-5 Outboard Ejector Rack Assembly (Sheet 1 of 2)

- |                        |                    |
|------------------------|--------------------|
| 1. Bolt                | 18. Foot           |
| 2. Washer              | 19. Spring         |
| 3. Packing             | 20. Packing        |
| 4. Gas tube            | 21. Piston         |
| 5. Ejection piston     | 22. Washer         |
| 6. Packing             | 23. Nut            |
| 7. Ejection cylinder   | 24. Left sideplate |
| 8. Cylinder cap        | 25. Screw          |
| 9. Orifice holder      | 26. Retainer       |
| 10. Packing            | 27. Screw          |
| 11. Packing            | 28. Packing        |
| 12. Back-up ring       | 29. Packing        |
| 13. Right sideplate    | 30. Washer         |
| 14. End spacer         | 31. Nut            |
| 15. Electrical plug    | 32. Screw          |
| 16. Cartridge retainer | 33. Screw          |
| 17. Packing            | 34. Screw          |

209071-384-2C

Figure 16-5. Outboard Rack Assembly (Sheet 2 of 2)

16-47. CLEANING/INSPECTION -  
OUTBOARD EJECTOR RACKS.

NOTE

After removal from the ejector rack, the ballistic components and the breech end ejection cylinder in the partially assembled ejector rack are cleaned to remove residue from the fired cartridges and then visually inspected for evidence of damage. The opening in the orifice is critical and must be checked for size as well as carefully cleaned. When visual inspection indicates evidence of wear or damage, send ejector rack to next higher maintenance level.

a. Clean components of the ballistic system using a warm solution of warm water and detergent (C113), and a soft bristle brush to loosen any caked residue.

**WARNING**

Cleaning solvent is flammable and toxic. Provide adequate ventilation. Avoid prolonged breathing of solvent vapors and contact with skin or eyes.

b. Rinse parts using dry cleaning solvent (C112) to remove moisture,

**WARNING**

To prevent injury to eyes, wear eye protection when using compressed air.

c. Dry all parts, particularly passages in breech and retainers, using a clean, lint-free cloth and filtered, low pressure air.

d. Ensure all loose matter is removed after cleaning and drying.

**CAUTION**

The sizes of openings in orifice holder (9, figure 16-5) are critical, and sharp objects such as drill bits shall not be used for cleaning out these openings. An increase in the 0.0370 ±0.005 inch diameter of center orifice will increase thrust applied to the ejector piston. An increase of 0.002 inch above maximum can increase the thrust as much as 20 percent.

NOTE

When necessary, use the shank of a drill bit 0.0370 inch in diameter to open center orifice (and the shank of a drill bit 0.060 inch in diameter for side orifices).

e. Use a soft wire (copper or brass) approximately **0.0370** inch in diameter to clean orifice in orifice holder (9). Ensure center and side openings are clear (approximately **0.060** inch diameter).

f. Inspect parts as follows:

(1) Visually examine all parts for cleanliness, evidence of corrosion, cracks and damaged threads.

(2) Visually examine openings in orifice holder (9) for obstruction and obvious distortion such as dents or cuts in area around openings. If damage is suspected, send ejector rack to next higher level of maintenance.

(3) Roll spring (19) across a flat surface to check for distortion.

(4) If dimensional or thread damage is suspected, send ejector rack to next higher level of maintenance.

## 16-48. ASSEMBLY - OUTBOARD EJECTOR RACKS.

### NOTE

**Exercise care in handling partially disassembled ejector rack during assembly to prevent accidental disassembly of shackles, linkage, and spring retainer spacers from bushings in right sideplate. Parts are spring loaded and if loosened from bushings, will fall out of partially assembled ejector rack causing additional assembly.**

### NOTE

**Apply a light coating of silicone grease (C59) to all packings and back-up rings prior to installation.**

a. Apply a light coating of silicone grease (C59) to packings (10 and 11, figure 16-5) and back-up ring (12) and install on orifice holder (9) in sequence shown in figure 16-5.

b. Install assembled orifice holder (9) in cylinder cap (8). Clamp cylinder cap in a vise to permit tightening and torque orifice holder (9) **95 TO 115** inch pounds. Lockwire (C137) cylinder cap (8) to orifice holder (9).

c. Install lubricated packing (6) inside groove in cylinder cap (8) to seal ejection cylinder (7).

d. Install lubricated packing (3) on each end of gas tube (4) and insert gas tube in opening in cylinder cap (8). Ensure packing (3) remains seated in groove.

e. Position cylinder cap (8) and gas tube (4) in partially assembled ejector rack, inserting end of gas tube in breech and trunnion of cylinder cap in bushing of right sideplate (13).

f. Install lubricated packing (17) in groove inside lower end of ejection cylinder (7), and insert ejection piston (5) inside ejection cylinder, extending end of piston out through end of cylinder. Do not bottom out piston in cylinder.

g. Holding ejection piston (5) at wrenching flats on end of piston, thread foot (18) into end of ejection piston (5). Do not bottom out foot to piston.

h. Install lubricated packings (28 and 29) in grooves in retainer (26).

i. Install lubricated packing (20) in groove in piston (21) and insert base of piston into opening in retainer (26).

j. Place spring (19) over piston (21) and install spring, piston and retainer (26) into breech. Do not tighten at this time.

k. Apply a light coating of grease (C58) to the exposed trunnions of the two shackles, the two shackle locking link-trunnions, and the hexagon release wrench trunnion. Ensure all six end spacers (14) are in bushings in right sideplate.

l. Position left sideplate (24) over partially assembled ejector rack, and, using a punch or other blunt object, align shackle, linkage trunnions and spring retainer spacer to bushing of left sideplate.

Install four screws (27) in sideplate and four bushings to retain sideplate while aligning the trunnions and spacers to bushings.

**NOTE**

**The spring retainer spacers can be aligned by inserting a blunt screwdriver in opening at bottom of ejector rack to carefully move spacers.**

**m.** After two shackle trunnions, three linkage trunnions and two spring retainer spacers are into bushings in right and left sideplates, check springs to ensure coils are not between shoulder of trunnions and sideplate, and tighten the four screws (27).

**n.** Install and tighten screw (35), four screws (34) and four screws (32).

**o.** Install bolt (1), two washers (30 and 2) and nut (31), placing one washer under head of bolt and one under nut. Torque nut (31) **95 TO 115** inch-pounds.

**p.** Install screw (24), washer (22) and nut (23). Torque nut on screw through both sideplates **50 TO 70** inch-pounds.

**q.** Install assembled ejection cylinder (7), ejection piston (5), packing (17) and foot (18) into breech, inserting end of cylinder into cylinder cap (8).

**r.** Torque retainer (26) in breech **95 TO 115** inch-pounds.

**s.** Torque ejection cylinder (7) in breech **290 TO 310** inch-pounds and lockwire (C137) ejection cylinder (7) to retainer (26).

**t.** Install two cartridge retainers (16) in breech. Tighten the two cartridge retainers finger tight. Do not install lockwire at this time.

**16-49. REMOVAL - INBOARD EJECTOR RACKS.**

**Premaintenance Requirements For Maintenance of Inboard Ejector Racks**

Conditions	Requirements
Model	AH-1S
Part No. or Serial No.	All

**Premaintenance Requirements For Maintenance of Inboard Ejector Racks (Cont)**

Conditions	Requirements
Special Tools	T13, T66
Test Equipment	T77
Support Equipment	None
Minimum Personnel Required	Two
Consumable Materials	C19, C37, C60, C78, C112
Special Environmental Conditions	None



**To prevent injury to personnel, ensure that all weapon systems are unloaded and all armament circuit breakers are OFF or out before starting any maintenance procedures or tests.**

**Serious injury can result from accidental ground jettison of inboard ejector racks.**

**a.** Preparation for Maintenance.

**(1)** Disconnect battery.

**(2)** Position all armament circuit breakers and switches to OFF



**Ensure all stores are properly supported before removing ground safety pin (1, figure 16-2).**

**(3)** Remove stores from rack using special rack release wrench (T66) (2, figure 16-2) for manual release.



**b. Removal Procedures.**

(1) Remove fakings (1, figure 16-6) from rack (12) and inboard leading edge of wing.

(2) Disconnect rack electrical cable (15) from connector in wing.

(3) Cut and remove lockwire from two cartridge retainers (9).

(4) Remove two cartridge retainers (9) and cartridges from breech assembly.

(5) Remove bolt (14), nut end washers to detach fork (13) of elevation adjustment fitting from front of rack. Do not change length of fitting.

(6) Remove two bolts (3), two nuts and washers to detach two turnbuckles (16) from fittings (2) on wing. Do not change length of turnbuckles.

(7) Remove lockwire and eight bolts, with washers and shims, to detach rack fittings (4) end remove rack assembly from wing. Observe locations of any shims for reinstallation.

**NOTE**

If rack is being removed to dean ejector, steps (6) and (9) are not required

(8) Remove bolts (5, 6 end 10) to detach fittings from rack Keep any shims found on bolts (5 and 10) for reinstallation.

(9) When necessary, remove attaching nuts and screws to separate inboard fittings and brace.

**16-50. INSPECTION — INBOARD EJECTOR RACKS.**

a. Visually inspect all fittings for crack, damage, and serviceable condition.

b. Inspect sway brace pads (11, figure 16-6), for security and ensure that locknut is securely in place.

c. Inspect fairing (1 ) for damage and serviceable condition.

d inspect ejector reck for corrosion, distortion of any parts, and evidence of damage.

e. Inspect electrical cable (15) for fraying or damaged connector.

f. Using depth gage, check protrusion of contact (4, figure 16-6.1). Contact protusion inside both cartridge bore breeches (5) shall be shown in figure 16-6.1.

**NOTE**

Contact is integral to wire harness (figure 16-6.2). If one-half turn or less of retainer (1, figure 16-6.1) does not bring contact protrusion within limits, refer to higher level of maintenance.

g. Inspect rack for cleanliness. If rack has been used to jettison stores, perform cleaning and inspection of ejector parts (paragraph 16-53).

**16-51. REPAIR — INBOARD EJECTOR RACKS.**

a. Replace any cracked, damaged, or unserviceable fittings.

b. Replace fairing (1) if unserviceable.

c. Remove corrosion from rack by using crocus cloth (C37) or phosphoric solution (C19).

**16-52. INSTALLATION — INBOARD EJECTOR RACKS.****NOTE**

Coat all common hardware on Inboard ejector rack with MIL-C-85054 (C44.3) MIL-C-85054 (C44.3) IAW TM 1-1500-344-23.

a. Assemble fittings (4, figure 16-6) if removed, on ejector rack (12) with bolts (5, 6, and 10). Ensure that original shims are in place between fittings on bolts (5 and 10). Use thin steel washers under bolt beds and nuts (do not fully tighten bolts at this time).

**NOTE**

Shims on bolts (5 and 10) provide 1.375 to 1.380 Inches between inside bosses of fittings at hole for bolt (6). If shims I re lost or mixed, assemble fittings without rack and prepare shims for correct dimension, then proceed with step b.

b. Lift rack and fitting assemblies in position. Align fittings (4) to mounting holes and install fourpairs of bolts with washers, using shims between wing and fittings at locations noted during removal of rack Torque bolts 100 TO 140 inch-pounds.

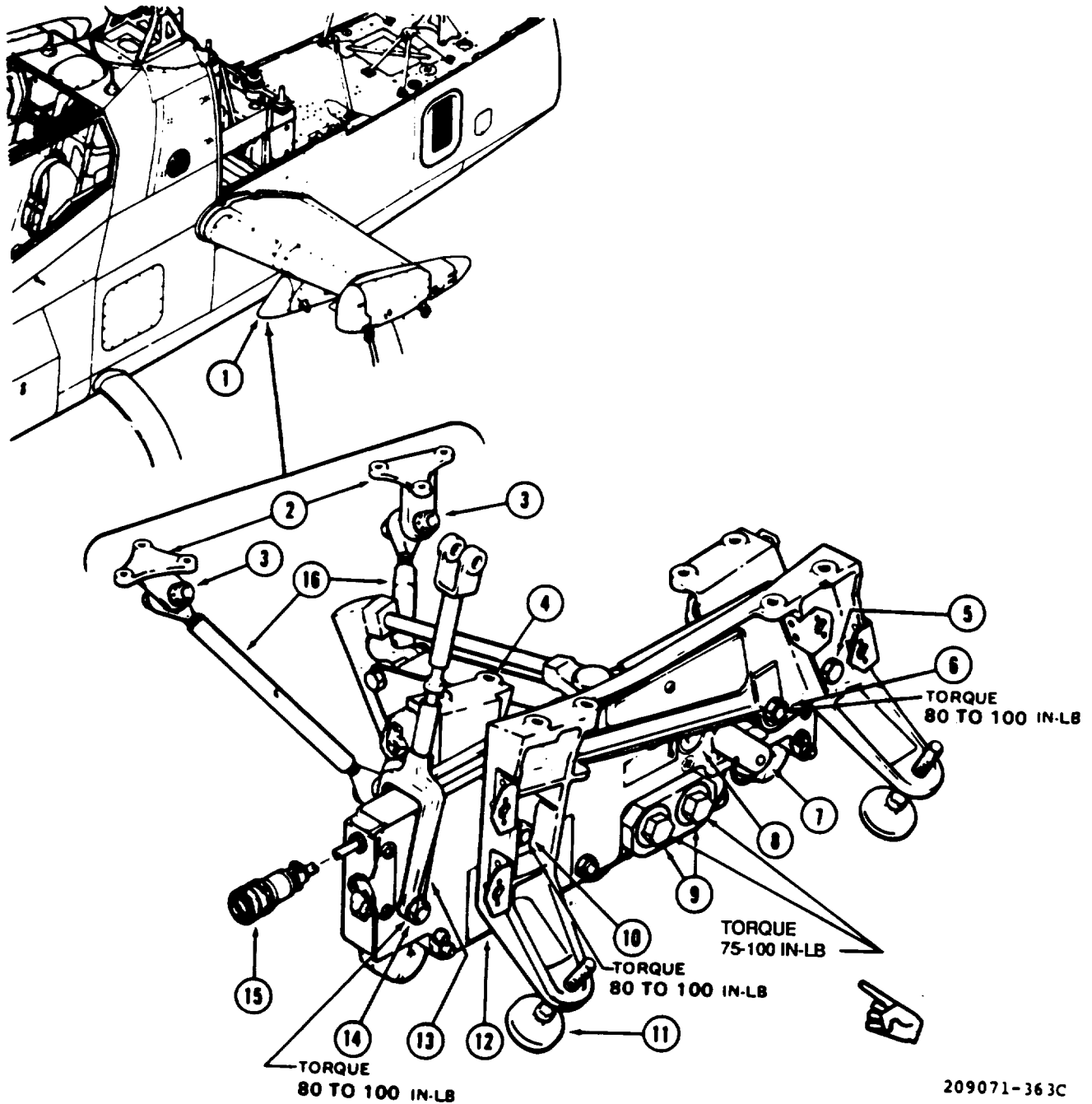

- |                      |                       |
|----------------------|-----------------------|
| 1. Fairing           | 9. Cartridge retainer |
| 2. Fitting           | 10. Bolt              |
| 3. Bolt              | 11. Sway brace pad    |
| 4. Fitting           | 12. Rack              |
| 5. Bolt              | 13. Fork              |
| 6. Bolt              | 14. Bolt              |
| 7. Quick release pin | 15. Cable             |
| 8. Manual release    | 16. Turnbuckle        |

Figure 16-6. Inboard Ejector Rack Installation

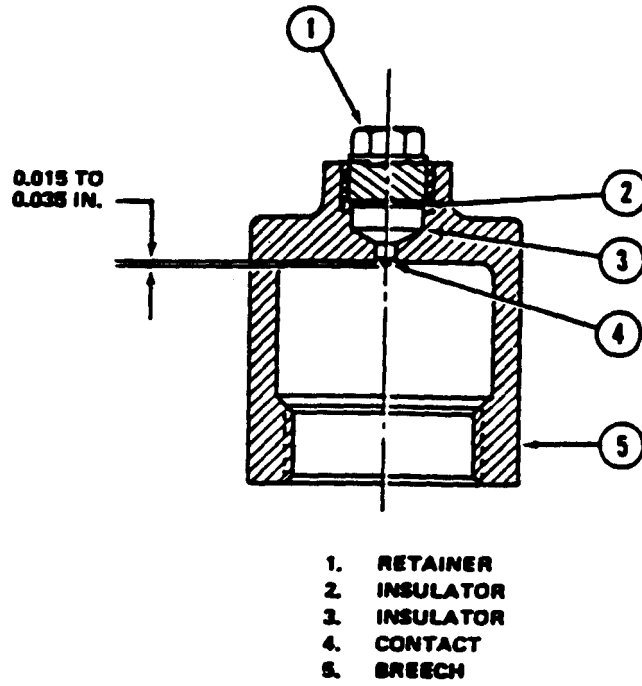
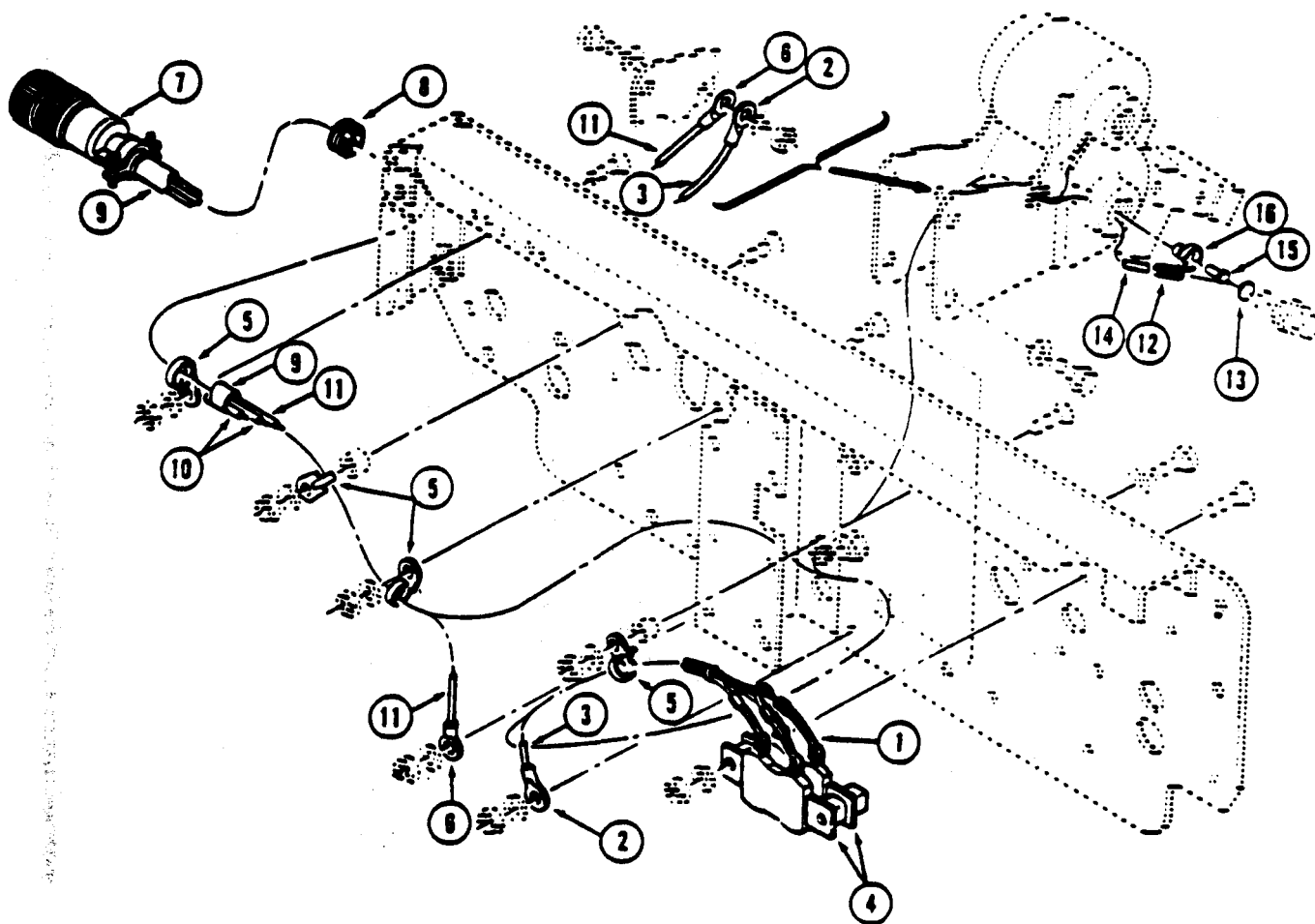

Figure 16-6.1. Contact Protrusion Inside Breech.



- |                            |                     |                           |
|----------------------------|---------------------|---------------------------|
| 1. THERMOFIT TUBING, 08795 | 7. CONNECTOR        | 12. THERMOFIT TUBING      |
| 2. TERMINAL                | 8. GROMMET          | 13. INSULATOR             |
| 3. WIRE                    | 9. THERMOFIT TUBING | 14. WIRE (15 INCH LENGTH) |
| 4. RESISTOR                | 10. WIRE            | 15. CONTACT               |
| 5. CLAMP                   | 11. WIRE            | 16. INSULATOR             |
| 6. TERMINAL                |                     |                           |

Figure 16-6.2. Wiring Harness Assembly.

c. Align fork (13) to forward hook pivot of rack, and install bolt (14) with thin steel washers under bolt head and nut. Align two turnbuckles (16) to fittings (2) and install two bolts (3) with thin washers under bolt heads and nuts. Adjust rod ends of turnbuckles (16) as required to provide ease of installation of bolts (3). If bolts do not fit freely, change or add shims between wing and fittings (4) to obtain alignment. Use no more than one shim per bolt.

d. Using gunner quadrant (T11), check rack for nose-up elevation of **71.1 (+8.9) mils (4 (+0.5) degrees)** with respect to fore and aft attitude of helicopter. If necessary to adjust rack, remove bolt (14) and adjust length of fork (13). Reinstall fork (13) to

(14), washers and nuts, and check for required angle. Repeat as necessary to achieve required angle.

e. When alignment of rack is satisfactory, lockwire (C137) bolts attaching fittings to wing in pairs. Torque bolts (6, 10 and 14) **80 TO 100** inch-pounds. Tighten bolt (5).

#### NOTE

Adjust ejector foot pad (16, figure 16-7) to snugly fit the specific armament weapon installed.

f. Check manual release (8) operation of rack,

#### WARNING

**Do not install cartridges in rack prior to continuity test.**

g. Connect rack electrical cable (15) to connector in leading edge of wing. Using multimeter (T77), perform electrical continuity test of wing stores jettison circuits (paragraph **P** 9-438, **E** 9-492 or **M** 9-552).

h. Install impulse cartridges (9) and cartridge retainers (10) (paragraph 16-36).

i. Install fairings (1) on wing leading edge and ejector rack (12).

### 16-53. CLEANING AFTER JETTISON - INBOARD EJECTOR RACKS.

Perform cleaning procedure as soon as possible after ejector rack has been used to jettison stores.

#### NOTE

**Inboard ejector rack must be removed from wing, but fittings can remain attached to rack (paragraph 16-49).**

a. Remove slave piston (12, figure 16-7) and compression spring (11) by removing retaining plug (15) and packings (14, 5 and 13).

#### NOTE

**Pins (8) are not used in this rack installation, Cartridge retainers (10) and cartridges (9) will have been removed during removal of rack.**

b. Remove plug (6) and breech plug (22).

c. Remove gas tube retainer (4) and gas tube assembly (3).

d. Remove piston retainer (18) and piston (21).

#### WARNING

**Cleaning solvent is flammable and toxic. Provide adequate ventilation. Avoid prolonged breathing of solvent vapors and contact with skin or eyes.**

e. Clean all internal surfaces of piston block and piston housing (1) with solvent (C112), using bore brushes to clean gas passages. Clean all removed parts with same solvent.

#### CAUTION

**To avoid excessive wear, clean firing contacts with a cloth and solvent only. Ensure that no dirt or portions of old cartridges remain in cartridge cavity.**

f. Coat all cleaned surfaces and parts with a very light coating of oil (C78). Parts should be almost dry. Cartridge cavity shall be left dry.

g. Coat all packings with grease (C60).

h. Replace any unserviceable parts.

#### NOTE

**Gas tube retainer (4) should be alternated between right and left inboard racks after each firing to minimize concentration of gas erosion on beveled surface at bottom of retainer. Retainer shall be replaced if erosion of beveled surface reaches center hole.**

i. Reassemble rack.

(1) Position packing (19) on piston (21) and insert piston into piston housing (1).

(2) Install packing (19) on piston retainer (18). Install piston retainer.

(3) Install packing (2) on gas tube assembly (3). Install packings (5) and gas tube retainer (4).

(4) Install packing (23) on breech plug (22) and install plug.

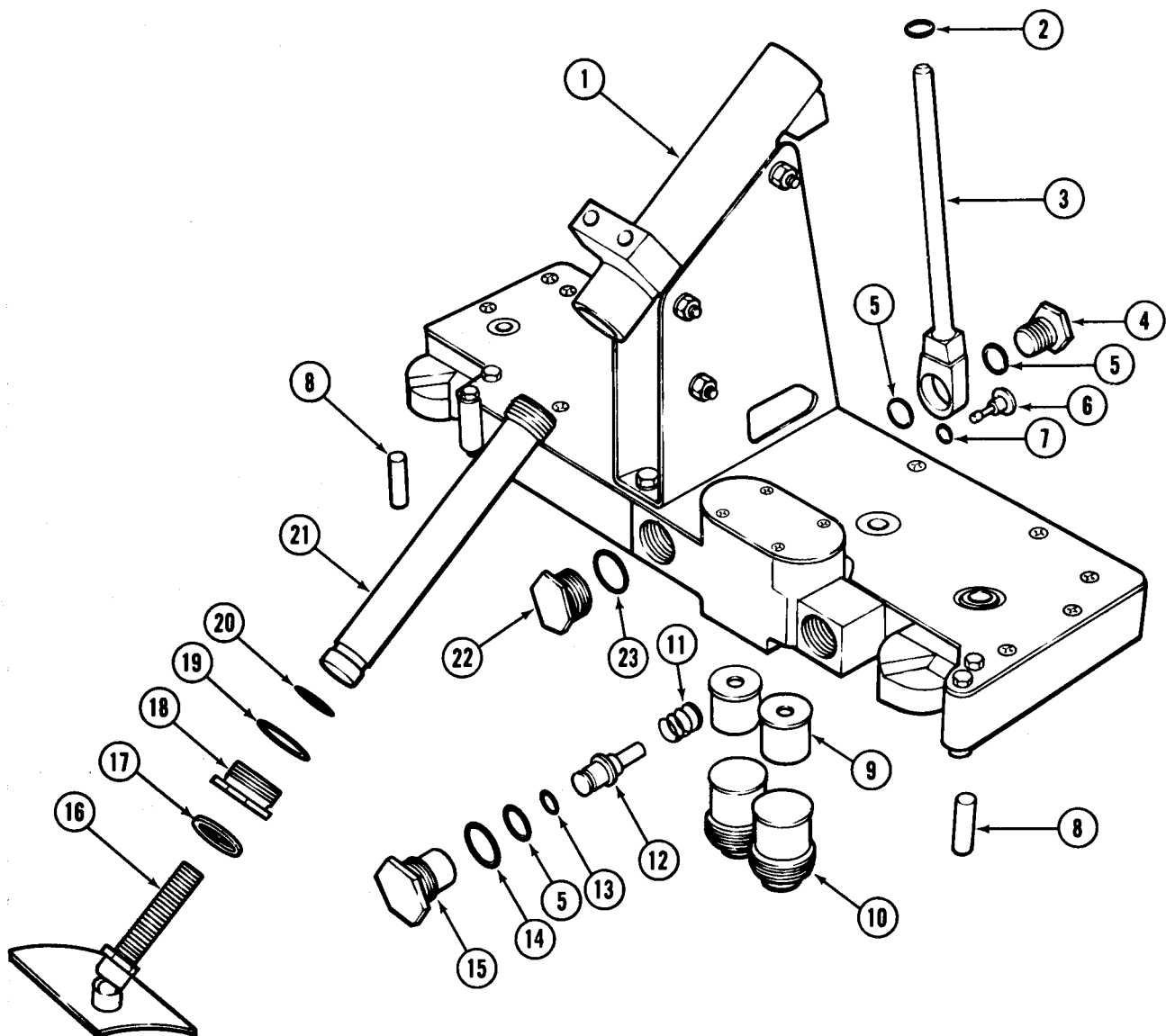

- |                      |                        |                     |
|----------------------|------------------------|---------------------|
| 1. Piston housing    | 9. Cartridge           | 17. Retaining ring  |
| 2. Packing           | 10. Cartridge retainer | 18. Piston retainer |
| 3. Gas tube assembly | 11. Compression spring | 19. Packing         |
| 4. Gas tube retainer | 12. Slave piston       | 20. Packing         |
| 5. Packing           | 13. Packing            | 21. Piston          |
| 6. Plug              | 14. Packing            | 22. Breech plug     |
| 7. Packing           | 15. Retaining plug     | 23. Packing         |
| 8. Pin               | 16. Ejector foot pad   |                     |

209071-365A

Figure 16-7. Inboard Ejector Rack Assembly

(5) Install packing (7) on plug (6) and Install plug.

(6) Install packings (5 and 14) on retaining plug (15).

(7) Install packing (13) on slave piston (12).

(8) Install compression spring (11), slave piston (12), and retaining plug (15).

j. Reinstall rack assembly on pylon (paragraph 16-52.)

**16-54. EJECTOR RACK FAIRINGS.**

**16-55. INSPECTION - EJECTOR RACK FAIRINGS.**

Inspect inboard and outboard fairings (figure 16-8) for cracks, damage and serviceable condition

**16-56. REMOVAL - EJECTOR RACK FAIRINGS.**

Remove inboard and outboard fairings (figure 16-8) from rack and leading edge of wing by removing screws and releasing the fasteners.

**16-57. REPAIR - EJECTOR RACK FAIRINGS.**

Replace any fairings that are damaged severely enough to prohibit proper functioning of ejector rack. Repair inboard and outboard fairings per TM 55-1500-204-25/1.

**16-58. INSTALLATION - EJECTOR RACK FAIRINGS.**

Install inboard and outboard fairings (figure 16-8) to the wing by locking fasteners and adding screws.

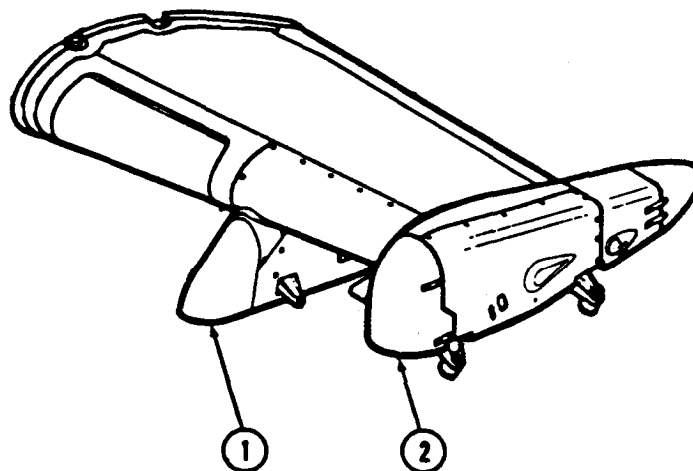

- 1. Inboard ejector fairing
- 2. Outboard ejector fairing

209071-394

Figure 16-8. Wing stores pylon and fairings

**16-59. CHAFF DISPENSER SUBSYSTEM.**

**16-60. DESCRIPTION OF DISPENSER, GENERAL PURPOSE, M-130.**

The dispenser, general purpose, aircraft: M130 (NSN 1095-01-036-6886) consists of a single system (dispenser assembly, payload module assembly, electronics module and dispenser control panel) designed to dispense chaff M-1. The system provides effective survival countermeasures against radar guided weapon systems threats. The dispenser system M130 has the capability of dispensing up to 30 chaff cartridges.

**NOTE**

**The flare dispenser function is not employed in the AH-1P, AH-1E, AH-1F helicopter.**

**16-61. MAINTENANCE - CHAFF DISPENSER SUBSYSTEM.**

Refer to TM 9-1095-206-13 & P for additional information and maintenance procedures. Refer to FO-143.

**16-62. M AIM-1/EXL LASER GUNSIGHT SUBSYSTEM.**

**16-63. M DESCRIPTION - AIM-1/EXLLASER GUNSIGHT SUBSYSTEM.**

The AIM-1/EXL aiming light is mounted on the gun saddle of the universal turret. It enables low-light/night target acquisition for the turret gun by using a boresighted infrared laser beam that can only be viewed with night vision goggles (NVGs). The AIM-1/EXL subsystem can be used in conjunction with the Helmet Sight Subsystem (HSS) when NVGs are worn. The AIM-1/EXL aiming light can operate in continuous mode or activated when ACTION switch on pilot cyclic control is pressed. Subsystem operations are controlled by the switch/relay assembly located on the outboard side of pilot's ash receiver.

**16-64. M MAINTENANCE - AIM-1/EXL LASER GUNSIGHT SUBSYSTEM.**

Removal and installation instructions for the AIM-1/EXL laser gunsight are given below. Refer to paragraph 9-573 in this manual for AIM-1/EXL laser

gunsight subsystem circuitry information. Refer to paragraph F-6 for airframe armament electrical equipment list, and paragraph F-9 for subsystem airframe wiring diagrams.

**16-65. M CLEANING - AIM-1/EXL LASER GUNSIGHT SUBSYSTEM.**

- a. Clean body of aiming light with a wet cloth.
- b. Clean front window with blower or soft brush. Wipe with optical paper.

**16-66. M INSPECTION - AIM-1/EXL LASER GUNSIGHT SUBSYSTEM.**

- a. Inspect electrical cable for fraying or damaged.
- b. Inspect aiming light for bending, cracks, fractions and loose parts.
- c. Inspect aiming light front window for scratches, cracks and humidity markings.

**16-67. M REMOVAL - AIM-1/EXL LASER GUNSIGHT SUBSYSTEM.**

Premaintenance Requirements for Maintenance of AIM-1/EXL Laser Assembly

Conditions	Requirements
Model	AH-1F
Part No. or Serial No.	All
Special Tools	None
Test Equipment	None
Support Equipment	None
Minimum Personnel Required	One
Consumable Materials,	C-137
Special Environmental Conditions	None



**WARNING**

The AIM-1/EXL laser is very dangerous. Ensure that the laser protective cover is kept over the emitter and AIM switch is off at all times.

## a. Preparation for Maintenance.

(1) Disconnect battery.

(2) Position all armament circuit breakers and switches to OFF.

## b. Removal Procedures.

(1) Disconnect electrical connector from aiming light (1, figure 16-9).

(2) Remove bolt (2), lockwasher (3), flat washer (4) and aiming light (1) from adapter (5).

(3) Cut lockwire securing two bolts (6). Remove two bolts (6), flat washers (7) and adapter (5).

**16-68. M REPAIR - AIM-1/EXL LASER GUNSIGHT SUBSYSTEM.**

a. Repair or replace connector and wiring if they fail to meet minimum serviceability standards.

b. Replace aiming light if damaged or defective. Evacuate removed aiming light to higher echelon for disposition.

**16-69. M INSTALLATION - AIM-1/EXL LASER GUNSIGHT SUBSYSTEM.****WARNING**

The AIM-1/EXL Laser is very dangerous. Ensure that the laser protective cover is kept over the emitter and AIM switch is off at all times.

a. Install adapter (5, figure 16-9) on right side of gun turret with two flat washers (7) and two bolts (6). Secure bolts with lockwire (C-137).

b. Install aiming light (1) on adapter (5) with flat washer (4), lockwasher (3) and bolt (2).

c. Connect electrical connector to aiming light (1).

**16-70. M FUNCTIONAL TEST - AIM-1/EXL LASER GUNSIGHT SUBSYSTEM.**

Refer to paragraph 9-575 and perform AIM-1/EXL laser gunsight subsystem circuitry test.

**16-71. M TROUBLESHOOTING - AIM-1/EXL LASER GUNSIGHT SUBSYSTEM.****WARNING**

The AIM-1/EXL laser beam is dangerous and can cause blindness if it enters the eye either directly or reflected from a shiny surface. Ensure that the laser protective cover is kept over the emitter and that the AIM power switch is off at all times when the laser is not in use. The laser shall be used only in controlled areas by qualified personnel. Night goggles are required during operation.

**NOTE**

Before using table, ensure all normal operational checks have been performed. If a malfunction is found which is not listed in table notify the next higher level of maintenance.

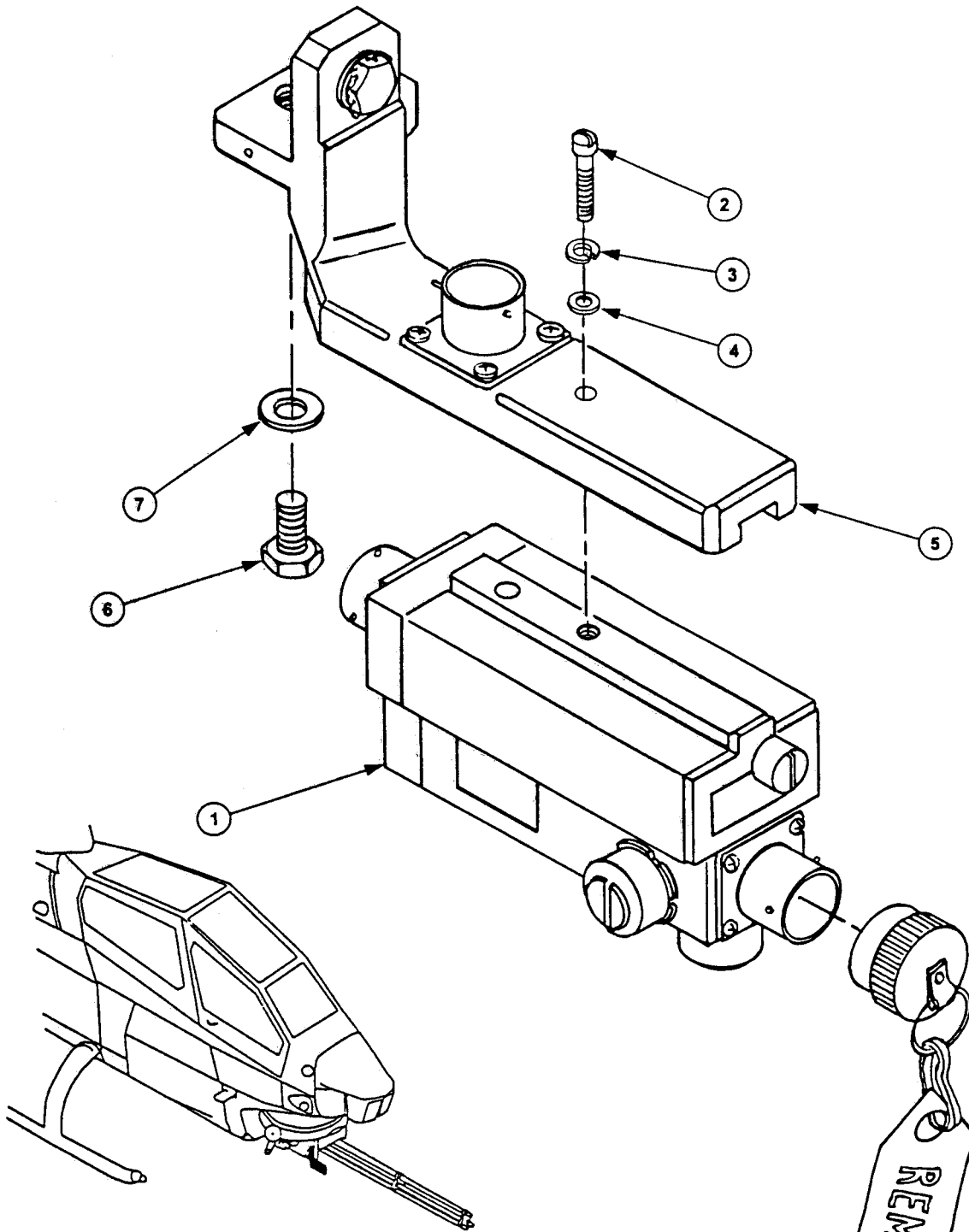

- 1. AIMING LIGHT
- 2. BOLT
- 3. LOCKWASHER
- 4. FLAT WASHER
- 5. ADAPTER
- 6. BOLT
- 7. FLAT WASHER

Figure 16-9. AIM-1/EXL Laser Installation

TABLE 16-3. **M**Troubleshooting AIM-1/EXL Laser Gunsight Subsystem

## CONDITION

## TEST OR INSPECTION

## CORRECTIVE ACTION

**WARNING**

**Night goggles are required during operation of AIM-1/EXL aiming light.**

1. With TURRET DRIVE MOTOR circuit breaker closed, no laser beam is seen when AIM switch is positioned in NORM or CONT when ACTION switch is depressed..

STEP 1. Laser window is covered.

**Remove protective cover from aiming light.**

STEP 2. Check for defective AIM switch.

**Replace switch (paragraphs 9-20 and 9-22).**

STEP 3. Check for defective wiring.

**Repair wiring (FO-118.1).**

STEP 4. Check for defective TURRET DRIVE MOTOR circuit breaker.

**Replace circuit breaker (paragraphs 9-27 and 9-29).**

STEP 5. Check aiming light for continuity.

**If continuity is not present notify the next higher level of maintenance.**

2. Aiming light is weak.

**Clean front window.**

3. Aiming light is blurred (diffused).

STEP 1. Check aiming front window.

**Clean front window.**

STEP 2. Check night vision goggles.

**Focus night vision goggles.**



## CHAPTER 17 EMERGENCY EQUIPMENT

### 17-1. CANOPY REMOVAL SYSTEM.

#### 17-2. DESCRIPTION - CANOPY REMOVAL SYSTEM.

The canopy removal system (CRS) consists of two window cutting assemblies (WCAs), two hinge cutting assemblies, two thrusters, two pin pullers, two arming/firing mechanisms (A/F), twelve interconnecting lines, and two inert manifolds (figure 17-1). Manual operation of any one of the two A/F mechanisms will cause explosive energy to be generated and routed by the shielded mild detonating cords (SMDCs) through the manifold to all other CRS components. The system then functions such that the two WCAs sever the gunner right and pilot left fixed window acrylic material around each window's periphery. Two linear shaped charge assemblies (LSCAs) sever both door hinges, the thrusters release both door match mechanisms and the pin pullers release both door counterpoise struts. The result is complete jettisoning of both doors and both fixed window transparencies.

**WARNING**

Ensure that both the pilot and gunner arming/firing mechanism handles are secured with safety pins (37 and 38, figure 17-1) prior to entry into the cockpit area.

**NOTE**

All unserviceable explosive items used in the CRS e.g; arm fire initiator, detonating cord, junction manifold interconnect line shall be tagged with NSN, nomenclature, lot number, installation date, removal date, reason for removal, helicopter type/model, serial number and returned to supporting ammunition supply activity in the container used to transport the replacement item.

### 17-3. WINDOW CUTTING ASSEMBLY.

#### 17-4. DESCRIPTION - WINDOW CUTTING ASSEMBLY.

The window cutting assemblies (1 and 20, figure 17-1) are mounted to the pilot and gunner window frames as shown in figure 17-1.

**Premaintenance Requirements  
For Window Cutting Assembly**

Conditions	Requirements
Model	AH-1P/E/F
Part No. or Serial No.	All
Special Tools	None
Test Equipment	None
Support Equipment	None
Minimum Personnel Required	Two
Consumable Materials	(C74), (C75), (C105), (C137)
Special Environmental Conditions	None

**WARNING**

Ensure that both the pilot and gunner arming/firing mechanism handles are secured with safety pins (37 and 38, Figure 17-1) prior to entry into the cockpit area.

**WARNING**

Activation of the canopy removal system when combustible fuel/vapors are present can result in an explosion/fire. Crew members survival knife may be used as an alternate means of egress.

### 17-5. INSPECTION - WINDOW CUTTING ASSEMBLY.

Inspect window cutting assemblies (1 and 20, figure 17-1) for cracks.

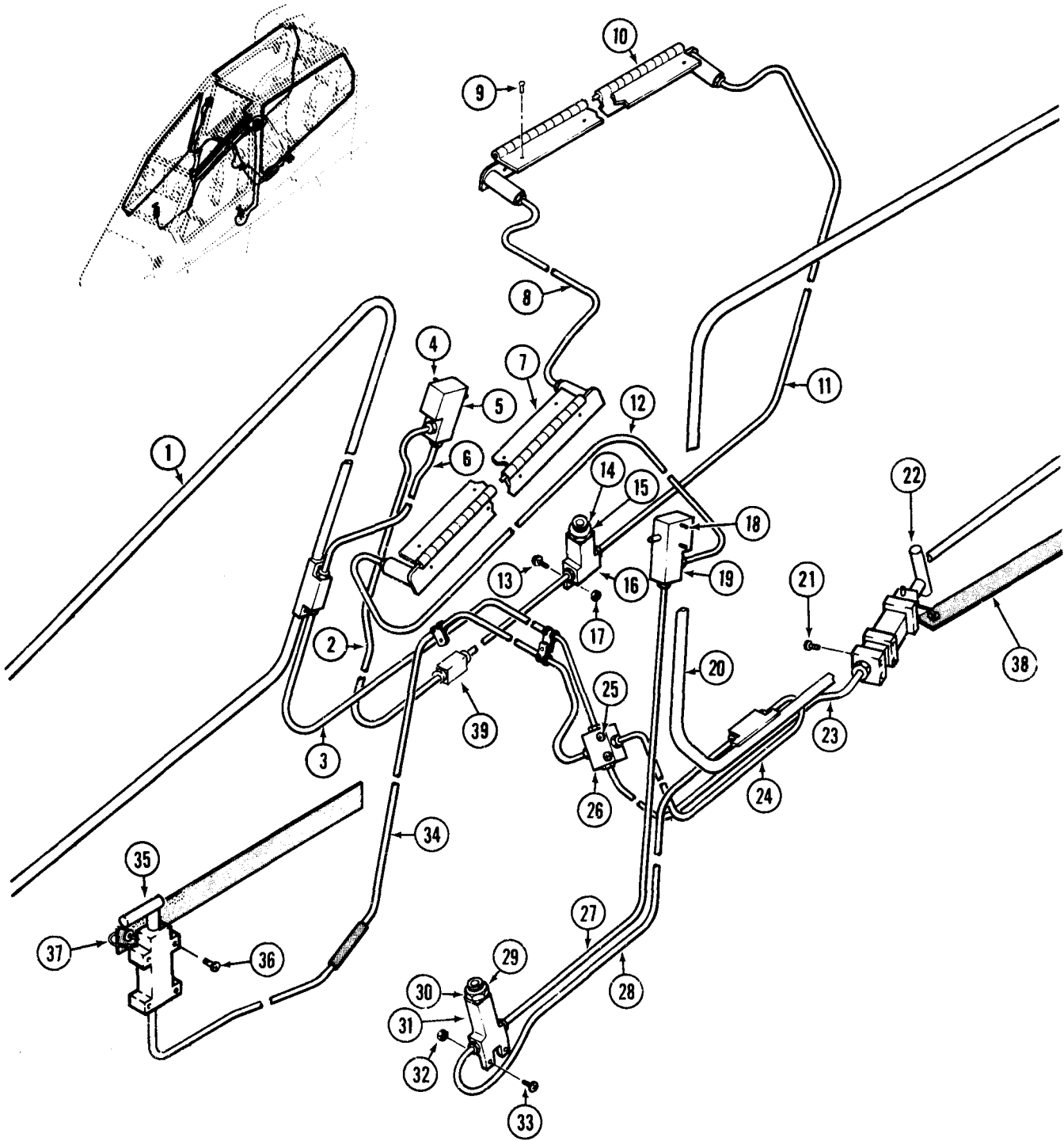

209033-44-1A

Figure 17-1. Canopy Removal System (Sheet 1 of 2)

- |  |  |
|--|--|
| <ol style="list-style-type: none"> <li>1. Window cutting assembly</li> <li>2. Pin puller Interconnect line</li> <li>3. Window cutter Interconnect line</li> <li>4. Screw</li> <li>5. Pin puller</li> <li>6. Window cutter Interconnect line</li> <li>7. Linear shaped charge assembly</li> <li>8. Linear shaped charge assembly Interconnect line</li> <li>9. Rivet</li> <li>10. Linear shaped charge assembly</li> <li>11. Linear shaped charge assembly Interconnect line</li> <li>12. Linear shaped charge assembly Interconnect line</li> <li>13. Screw</li> <li>14. Jamnut</li> <li>15. Shim</li> <li>16. Thruster</li> <li>17. Nut</li> <li>18. Screw</li> <li>19. Pin puller</li> </ol> | <ol style="list-style-type: none"> <li>20. Window cutting assembly</li> <li>21. Screw</li> <li>22. Arming/firing mechanism</li> <li>23. Arming/firing mechanism Interconnect line</li> <li>24. Window cutter Interconnect line</li> <li>25. Screw</li> <li>26. Junction manifold</li> <li>27. Pin puller Interconnect line</li> <li>28. Window cutter Interconnect line</li> <li>29. Shim</li> <li>30. Jamnut</li> <li>31. Thruster</li> <li>32. Nut</li> <li>33. Screw</li> <li>34. Arming/firing mechanism Interconnect line</li> <li>35. Arming/firing mechanism</li> <li>36. Screw</li> <li>37. Ground safety pin</li> <li>38. Ground safety pin</li> <li>39. In-line connector</li> </ol> |
|--|--|

Figure 17-1. Canopy Removal System (Sheet 2 of 2)

**17-6. REMOVAL - WINDOW CUTTING ASSEMBLY (AVIM).**

- a. Disconnect interconnect lines (3 and 6, or 24 and 28, figure 17-1) from adapter on window cutting assembly (1 or 20). Cap lines.
- b. **M** Disconnect and remove air data subsystem wiring at aft upper corner of window cutting assembly (1).
- c. Remove screws securing window transparency and window cutting assembly to window frame and remove cutting assembly.

**WARNING**

Cleaning solvent is flammable and toxic. Provide adequate ventilation. Avoid prolonged breathing of solvent vapors and contact with skin or eyes.

**CAUTION**

Do not allow any ketone-type solvents to contact window transparencies. These solvents will damage the transparencies by attacking the plastic materials.

- d. Use a putty knife or other suitable tool to loosen sealant. Clean sealant from window transparency with naphtha (C75), and from frame with MEK (C74).

**17-7. REPAIR OR REPLACEMENT - CRACKED WINDOW CUTTING ASSEMBLY.**

Replace window cutting assembly if cracked or damaged.

**17-8. INSTALLATION - WINDOW CUTTING ASSEMBLY (AVIM).**

- a. Position window cutting assembly (1 or 20, figure 17-1) in place between window transparency and door frame.
- b. Use holes in window frame as a guide and drill holes through window cutting assembly and window glass using a hole finder. Use fasteners as holes are drilled to maintain alignment.
- c. After all holes are drilled, remove glass and window cutting assembly from frame and clean all cuttings from parts.
- d. Apply sealant (C105) to faying surfaces of window cutting assembly.
- e. Place window cutting assembly (1 or 20) and glass on window frame and install mounting screws.

f. **M** Route and connect air data subsystem wiring at aft upper corner of window cutting assembly (1).

g. Connect interconnect line end fitting (3 and 6 or 24 and 28) to window cutting assembly. Torque nut **30 TO 45** inch-pounds.

### 17-9. LINEAR SHAPED CHARGE ASSEMBLY.

### 17-10. DESCRIPTION - LINEAR SHAPED CHARGE ASSEMBLY.

The linear shaped charge assemblies (7 and 10, figure 17-1) are mounted to the canopy frame inboard of the top of the pilot and gunner doors. In case of an emergency the charge assembly will sever the door hinge.

#### WARNING

Ensure that both the pilot and gunner arming/firing mechanism handles are secured with safety pins (37 and 38, figure 17-1) prior to entry into the cockpit area.

### 17-11. INSPECTION - LINEAR SHAPED CHARGE ASSEMBLY.

Inspect linear shaped charge assembly (7 or 10, figure 17-1) and plastic covering for the following:

- a. Security.
- b. Nicks, dents, scratches, and corrosion in accordance with figure 17-2.
- c. Inspect linear explosive for damage or cracks.

### 17-12. REMOVAL - LINEAR SHAPED CHARGE ASSEMBLY (AVIM).

- a. Remove door from helicopter (paragraph 2-131).
- b. Disconnect interconnect lines (8 and 11 or 12, figure 17-1) from each end of linear shaped charge assembly (7 or 10). Cap lines.

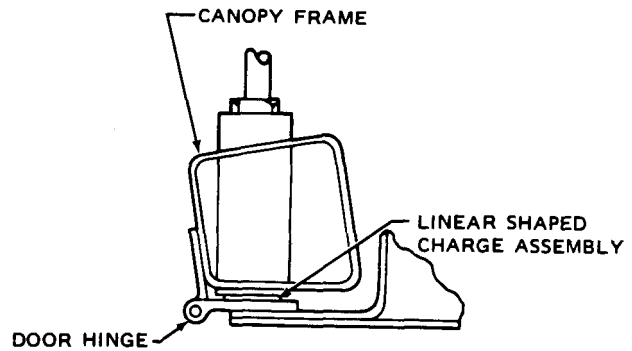

VIEW A

1. Nicks, dents, scratches, and corrosion are acceptable along entire length of linear shaped charge assembly or plastic covering if depth does not exceed 0.010 inch when polished out to remove damage.
2. Cuts, breaks, or tears in plastic tube covering are not acceptable.

209033-67

Figure 17-2. Damage Limits - Linear Shaped Charge Assembly

c. Remove rivets (9) securing linear shaped charge assembly to door frame and disengage assembly from frame.

### 17-13. INSTALLATION - LINEAR SHAPED CHARGE ASSEMBLY. (AVIM).

- a. Position linear shaped charge assembly in place on canopy frame.
- b. Using a hole finder drill holes in linear shaped charge assembly (7 or 10, figure 17-1) to match holes in door frame and install rivets (9).
- c. Connect interconnect lines (8 and 11 or 12) at each end of charge assembly. Torque nut **30 TO 46** inch-pounds.
- d. If charge assembly has been fired, install new hinge on door.
- e. Install door (paragraph 2-137).



**17-14. SIGNAL TRANSMISSION SUBSYSTEM.****17-15. DESCRIPTION - SIGNAL TRANSMISSION SUBSYSTEM.**

The signal transmission subsystem consists of interconnecting lines of detonating cord with threaded connections for attachment to window cutting assembly and linear shaped charge assembly adapters, junction manifolds, and an arming/firing mechanism. The arming/firing mechanism is activated when the handle is rotated 90 degrees counterclockwise to arm, then pulled to fire primer charge. The junction manifolds are used to connect the systems together.

**17-16. INSPECTION - SIGNAL TRANSMISSION SUBSYSTEM.****WARNING**

Ensure that both the pilot and gunner arming/firing mechanism handles are secured with safety pins (37 and 38, figure 17-1) prior to entry into the cockpit area.

a. Inspect all interconnect lines (figure 17-1) for nicks, dents, scratches, and for secure installation.

b. Inspect arming/firing mechanism (22 and 35) for nicks, dents, scratches, and for secure installation.

c. Inspect pinpullers (5 and 19), if the piston is in the release position or if the piston can be pushed in with minimal effort replace the pinpuller.

**17-17. REMOVAL - SIGNAL TRANSMISSION SUBSYSTEM. (AVIM)****a. Interconnecting Lines.**

(1) Remove clamps as necessary to detach line from structure.

(2) Cut lockwire and disconnect each end of line from junction manifold (26, figure 17-1), in line connector (39), window cutting assembly (1 or 20), arming/firing mechanism (22 or 35), linear shaped charge assembly (7 or 10), thruster (16 or 31) or pin puller (5 or 19).

(3) Install protective caps and plugs.

**b. Arming/Firing Mechanism.**

(1) Cut lockwire and disconnect interconnect line (23 or 34) from arming/firing mechanism (22 or 35).

(2) Install protective cap and plug,

(3) Remove four screws (21 or 36) to detach mechanism from bracket.

**c. Junction Manifold.**

(1) Cut lockwire and disconnect interconnect lines (3, 23, 24, and 34) from junction manifold (26).

(2) Install protective caps and plugs.

(3) Remove two screws (25) to detach manifold from bracket.

**d. Pin Puller.**

(1) Cut lockwire and disconnect interconnect lines (2 and 6 or 12 and 27) from pinpuller (5 or 19).

(2) Install protective caps and plugs.

(3) Remove two screws (4 or 18) to detach pin puller (5 or 19) from canopy frame.

**e. Thruster.**

(1) Cut lockwire and disconnect interconnect lines (2 and 11 or 27 and 28) from thruster (16 or 31).

(2) Install protective caps and plugs.

(3) Remove two screws (13 or 33) and two nuts (17 or 32) securing thruster (16 or 31) to structure.

(4) Remove jamnut (14 or 30) and shims (15 or 29) from thruster (16 or 31) and detach thruster from bracket.

**17-18. INSTALLATION - SIGNAL TRANSMISSION SUBSYSTEM. (AVIM)****a. Interconnecting Lines.**

(1) Remove protective caps and plugs.

(2) Connect each end of line to junction manifold (26, figure 17-1), in-line connector (39), window cutting assembly (1 or 20), arming/firing

mechanism (22 or 35), linear shaped charge assembly (7 or 10), thruster (16 or 31), or pin puller (5 or 19). Torque nuts **30 TO 45** inch-pounds.

(3) Lockwire (C137) nuts.

(4) Secure lines in place on structure with applicable clamps.

**b. Arming/Firing Mechanism.**

(1) Secure mechanism (22 or 35) to bracket with four screws (21 or 36).

(2) Remove protective cap and plug.

(3) Connect interconnect line (23 or 34) to mechanism (22 or 35), Torque nut **30 TO 45** inch-pounds.

(4) Lockwire (C137) nut.

**c. Junction Manifold.**

(1) Secure manifold (26) to bracket with two screws (25).

(2) Remove protective caps and plugs.

(3) Connect interconnect lines (3, 23, 24 and 34) to manifold (26). Torque nuts **30 TO 46** inch-pounds.

(4) Lockwire (C137) nuts.

**d. Pin Puller.**

(1) Secure pin puller (5 or 19) to canopy frame with two screws (4) or 18).

(2) Remove protective caps and plugs.

(3) Connect interconnect lines (2 and 6 or 12 and 27) to pin puller (5 or 19). Torque nuts **30 TO 45** inch-pounds.

(4) Lockwire (C137) nuts.

**e. Thruster.**

(1) Place thruster (16 or 31) through hole in bracket and attach with shims (15 or 29) and jamnut (14 or 30).

(2) Secure thruster (16 or 31) to structure with two screws (13 or 33) and two nuts (17 or 32).

(3) Remove protective caps and plugs.

(4) Connect interconnect lines (2 and 11 or 27 and 28) to thruster (16 or 31). Torque nuts **30 TO 46** inch-pounds.

(5) Lockwire (C137) nuts.

**17-19. FIRST AID KIT.**

**17-20. DESCRIPTION - FIRST AID KIT.**

The first aid kit is fastened with snap fasteners behind the pilot seat.

**17-21. REMOVAL - FIRST AID KIT.**

Pull outward on kit to release fasteners.

**17-22. INSPECTION - FIRST AID KIT.**

Refer to TM 55-1500-328-25.

**17-23. INSTALLATION - FIRST AID KIT.**

Position kit on fasteners and push to engage fasteners.

**17-24. FIRE EXTINGUISHER.**

**17-25. DESCRIPTION - FIRE EXTINGUISHER.**

The fire extinguisher is installed on the floor of a bracket in front of gunner seat.



When helicopter is to be parked where ambient temperature equals or exceeds 90 degrees F (32 degrees C), the fire extinguisher shall be removed until the next mission.

Should an extinguisher inadvertently be left in the helicopter during a high temperature period, the extinguisher shall be weight checked prior to the next mission.

**WARNING**

Exposure to high concentrations of monobromotrifluoromethane (CF<sub>3</sub>Br) extinguishing agent or decomposition products should be avoided. The liquid should not be allowed to come into contact with the skin, as it may cause frostbite, low-temperature burns, or severe irritation of eyes and nose.

**17-26. REMOVAL - FIRE EXTINGUISHER.**

a. Unlatch holding strap and lift extinguisher from bracket.

b. Remove retaining screws and washers and remove bracket from floor panel.

**17-27. INSPECTION - FIRE EXTINGUISHER.**

a. Inspect fire extinguisher for obvious physical damage.

b. Inspect handle for security.

c. Check that handle safety pin is installed and secure.

d. Weigh fire extinguisher every six months (as recorded on inspection label) and ensure that it weighs no less than four ounces below fully charged gross weight stamped on nameplate.

e. inspect fire extinguisher mounting bracket for damage and security.

**17-28. REPAIR - FIRE EXTINGUISHER.**

a. Replace fire extinguisher that is damaged or does not meet fully charged weight requirements.

b. Repair or replace damaged mounting bracket as applicable.

**17-29. INSTALLATION - FIRE EXTINGUISHER.**

a. Attach bracket to floor panel with screws and washers.

b. Place extinguisher in bracket and latch in place with holding strap.

**17-30. SURVIVAL KIT.****17-31. DESCRIPTION - SURVIVAL KIT.**

Provisions for the customer furnished survival kit are installed on the bulkhead aft of the pilot.



## APPENDIX A

## REFERENCE

The following references of the issue in effect, are required for use by aviation unit and intermediate maintenance personnel in performance of their duties.

NUMBER	TITLE
AR 95-1	Army Aviation General Provisions and Flight Regulations
AR 95-3	Weight and Balance, Army Aircraft
AR 95-5	Aircraft Accident Prevention and Investigation
AR 310-50	Authorized Abbreviations and Brevity Codes
AR 750-50	Aircraft Cannibalization
AR 755-15	Disposal of Unwanted Radioactive Material
DA PAM 738-751	The Army Maintenance Management System (TAMMS)
FM 10-68	Aircraft Refueling
FM 10-69	Petroleum Handling and Operation
FM 55-413	Aerial Recovery of Aircraft
MIL-L-6866	Penetrant Method of Inspection
MIL-L-6868	Magnetic Particle Inspection Process
TB MED 501	Noise and Conservation of Hearing
■ TB 1-1615-351-23	Rotor Blade Erosion Protection
TB 43-0106	Army Oil Analysis Program
TB 750-25	Maintenance of Supplies and Equipment Army Metrology and Calibration System
TB 55-1500-334-25	Conversion to Fire Resistant Hydraulic Fluid
TB 55-1560-276-24/1	Polish Kit, Glass, Part Number: RS-69, NSN: 1560-00-450-3622
TB 55-9150-200-24	Engine and Transmission Oils, Fuels, and Additives for Army Aircraft
TM 1-7R1-3-1-1	Cleaning, Testing, and Corrosion Treatment of Air Cooled Aluminum, Brass and Copper Type Oil Coolers
TM 1-1520-250-23-1	General Tie-Down and Mooring Technical Manual Aviation Unit and Intermediate Maintenance All Series Army Models AH-64, UH-60, CH-47, UH-1, AH-1, OH-58 Helicopters
TM 9-1095-206-13 & P	Operation Aviation Unit Maintenance and Aviation Intermediate Maintenance Manual (Including Repair Parts and Special Tool Lists) for Dispenser, General Purpose Aircraft XM130
TM 10-1101	Petroleum Handling and Operation (superseded by FM 10-69)

**TM 55-1520-236-23**

NUMBER	TITLE
TM 1-1500-328-25	Aeronautical Equipment Maintenance Management Policies and Procedures
TM 11-1520-236-20	Organizational Maintenance Manual: Electronic Equipment Configurations (AH-1S)
TM 11-1520-236-34	Direct and General Support Maintenance Manual: Electronic Equipment Configurations (AH-1S)
TM 11-6125-220-12	Organizational Maintenance Manual: Motor-Generator PU-543/A (Modified), PU-543 A/A (modified), PU-543 B/A, PU-543 C/A, and PU-543 D/A.
TM 11-6130-385-34	Direct Support and General Support Maintenance Manual: Inverter, Static Power PP-7274/A
TM 11-6140-203-14-2	Operators, Organizational, Direct Support, General Support, and Depot Maintenance Manual for Aircraft Nickel-Cadmium Batteries
TM 3-220	Chemical, Biological and Radiological (CBR) Decontamination
TM 43-0105	Corrosion Control for Army Aircraft
TM 55-1500-204-25/1	General Aircraft Maintenance Manual
TM 55-1500-220-PM	Phased Maintenance Checklist
TM 55-1500-220-PMD	Preventive Maintenance Daily Checklist
TM 55-1500-322-24	Organizational, Direct, and General Support Maintenance Manual: Cleaning Procedure for Army Aircraft
TM 55-1500-326-24	General Aircraft Maintenance Manual: Standards of Serviceability for Transfer of Aircraft.
TM 55-1500-333-24	Organizational, Direct Support, and General Support Maintenance Manual: Cleaning Procedure for Army Aircraft
TM 55-1500-335-23	Non-Destructive Inspection Methods
TM 55-1500-342-23	Army Aviation Maintenance Engineering Manual: Weight and Balance
TM 55-1500-345-23	Painting and Marking of Army Aircraft.
TM 55-1520-236-MTF	Aircraft Maintenance Test Flight Manual for AH-1P/E/F Aircraft
TM 55-1520-236-T	Aviation Unit and Intermediate Maintenance Level Troubleshooting Instructions; Integrated Armament and Fire Control Systems; AH-1S (MC).
TM 55-1520-236-10	Operators Manual: Army Model (AH-1P/E/F)
TM 55-1520-236-23P	Aviation Unit and Intermediate Maintenance Repair Parts and Special Tools List (Including Depot Maintenance Repair Parts and Special Tools); Helicopter, Attack, AH-1P/E/F
TM 55-2620-200-24	Inspection, Maintenance Instructions, Storage and Disposition of Aircraft Tires and Inner Tubes

NUMBER	TITLE
TM 55-2840-229-24	Organizational, Direct Support, and General Support Maintenance Manual: Engine, Shaft Turbine
TM 55-4920-201-14	Operators, Organizational, Direct Support, and General Support Maintenance Manual: Including Repair Parts and Special Tools List: Balancing and Adapter Kits
TM 55-4920-244-14	Operators, Organizational, Direct Support, and General Support Maintenance Manual (Including Repair Parts and Special Tools List) for Tester, Exhaust Gas Temperature, Model: BH 112JA-36.
TM 55-4920-401-13&P	Operators, Organizational and Direct Support Maintenance Manual (Including Repair Parts and Special Tools List) for Exhaust Gas Temperature Tester, BH112JB-53
TM 740-90-1	Administrative Storage of Equipment
TM 9-1055-460-14	Operator, Organizational, Direct Support, and General Support Maintenance Manual (Including Repair Parts and Special Tool Lists with Depot Maintenance Allowance): 2.75 Inch Aircraft Rocket Launchers M158A1, M200 and M200A1
TM 9-1090-203-12	Operator and Organizational Maintenance Manual for Armament Subsystem, Helicopter 7.62 Millimeter, 40mm Gernade Launcher: M28A1
TM 9-1270-212-14	Operator, Organizational, Direct Support, and General Support Maintenance Manual for MI 28 and MI 36 Helmet-Sight Subsystem (HSS)
TM 9-1270-217-13&P	Operators, Aviation Unit and Intermediate Maintenance Manual with Repair Parts and Special Tools List (Including Depot Maintenance Repair Parts and Special Tools) for Rocket Management Subsystem, Inventory-Deployment, XM138
TM 9-1270-218-13	Aviation Unit and Aviation Intermediate Maintenance Manual for Fire Control Computer Subsystem XM22.
TM 9-1270-219-13	Operator Aviation Unit and Aviation Intermediate Maintenance Instructions
TM 9-1270-220-13	Aviation Unit and Aviation Intermediate Maintenance Manual for Head-Up Display, Subsystem XM76
TM 9-1425-473-20	Organizational Maintenance Manual for Armament Subsystem, Helicopter, TOW Guided Missile XM65
TM 9-1425-473-34	Direct and General Support Maintenance Manual, Armament Subsystem, Helicopter, TOW Guided Missile XM65





## APPENDIX B

### MAINTENANCE ALLOCATION CHART

---

#### SECTION I. INTRODUCTION

#### **B-1 . MAINTENANCE ALLOCATION CHART**

a. This Maintenance Allocation Chart (MAC) assigns maintenance functions in accordance with the Three Levels of Maintenance concept for army aircraft. These maintenance levels, Aviation Unit Maintenance (AVUM); Aviation Intermediate Maintenance (AVIM) and Depot Maintenance are depicted on the MAC as:

AVUM which corresponds to the O Code in the RPSTL

AVIM which corresponds to an F Code in the RPSTL  
DEPOT which corresponds to a D Code in the RPSTL

b. The maintenance to be performed below depot and in the field is described as follows:

(1) Aviation Unit Maintenance (AVUM) activities will be staffed and equipped to perform high frequency "On-Aircraft" maintenance tasks required to retain or return aircraft to a serviceable condition. The maintenance capability of the AVUM will be governed by the Maintenance Allocation Chart (MAC) and limited by the amount and complexity of ground support equipment (GSE), facilities required, and number of spaces and critical skills available. The range and quantity of authorized spare modules/components will be consistent with the mobility requirements dictated by the air mobility concept. (Assignments of maintenance tasks to divisional company size aviation units will consider the overall maintenance capability of the division, the requirement to conserve personnel and equipment resources and air mobility requirements.)

(a) Company Size Aviation Units: Perform those tasks which consist primarily of preventive maintenance and maintenance repair and replacement functions associated with sustaining a high level of aircraft operational readiness. Perform maintenance inspections and servicing to include

preflight, daily, intermediate, periodic, and special inspections as authorized by the MAC or higher headquarters. Identify the cause of equipment/system malfunctions using applicable technical manual troubleshooting instructions, built-in-test equipment (BITE), installed aircraft instruments, or easy to use/interpret diagnostic/fault isolation devices (TMDE). Replace worn or damaged modules/components which do not require complex adjustments or system alignment and which can be removed/installed with available skills, tools and equipment. Perform operational and continuity checks and make minor repairs to the electrical system. Inspect, service, and make operational, capacity, and pressure checks to hydraulic systems. Perform servicing, functional adjustments, and minor repair/replacement to the flight control, propulsion, power train, and fuel systems. Accomplish air frame repair which does not require extensive disassembly, jiggling, or alignment. The manufacture of air frame parts will be limited to those items which can be fabricated with tools and equipment found in current air mobile tool and shop sets. Evacuate unserviceable modules/components and end items beyond the repair capability of AVUM to the supporting AVIM.

(b) Less than Company Size Aviation Units: Aviation elements organic to brigade, group, battalion headquarters, and detachment size units are normally small and have less than ten aircraft assigned. Maintenance tasks performed by these units will be those which can be accomplished by the aircraft crew chief or assigned aircraft repairman and will normally be limited to preventive maintenance, inspections, servicing, spot painting, stop drilling, application of nonstress patches, minor adjustments, module/component fault diagnosis, and replacement of selected modules/components. Repair functions will normally be accomplished by the supporting AVIM unit.

(2) Aviation Intermediate Maintenance (AVIM) provides mobile, responsive "One Stop"

maintenance support. (Maintenance functions which are not conducive to sustaining air mobility will be assigned to depot maintenance). Performs all maintenance functions authorized to be done at AVUM. Repair of equipment for return to user will emphasize support or operational readiness requirements. Authorized maintenance includes replacement and repair of modules/components and end items which can be accomplished efficiently with available skills, tools, and equipment, Established the Direct Exchange (DX) program for AVUM units by repairing selected items for return to stock when such repairs cannot be accomplished at the AVUM level. Inspects, troubleshoots, test diagnoses, repairs, adjusts, calibrates, and aligns aircraft system modules/components. AVIM units will have capability to determine the serviceability of specified modules/components removed prior to the expiration of the Time Between Overhaul (TBO) or finite life. Module/component disassembly and repair will support the DX program and will normally be limited to tasks requiring cleaning and the replacement of seals, fittings, and items of common hardware. Airframe repair and fabrication of parts will be limited to those maintenance tasks which can be performed with available tools and test equipment. Unserviceable reparable modules/components and end items which are beyond the capability of AVIM to repair will be evacuated to Depot Maintenance. This level will perform aircraft weight and balance inspections and other special inspections which exceed AVUM capability. Provides quick response maintenance support, including aircraft recovery and air evacuation, on-the-job training, and technical assistance through the use of mobile maintenance contact teams. Maintains authorized operational readiness float aircraft. Provides collection and classification services for serviceable/unserviceable material. Operates a cannibalization activity in accordance with AR 750-50. (The aircraft maintenance company within the maintenance battalion of a division will perform AVIM functions consistent with air mobility requirements and conservation of personnel and equipment resources. Additional intermediate maintenance support will be provided by the supporting nondivisional AVIM unit).

## B-2. USE OF THE MAINTENANCE ALLOCATION CHART.

a. The Maintenance Allocation Chart assigns maintenance functions based on past experience and the following consideration:

- (1) Skills available.

- (2) Time required.

- (3) Tools and test equipment required and/or available.

b. The assigned levels of maintenance authorized to perform a maintenance function is indicated.

c. A maintenance function assigned to a lower maintenance level will automatically be authorized to be performed at any higher maintenance level.

d. A maintenance function that cannot be performed at the assigned level of maintenance for any reason may be evacuated to the next higher maintenance organization. Higher maintenance levels will perform the maintenance functions of lower maintenance levels when required or directed by the appropriate commander.

e. The assignment of a maintenance function will not be construed as authorization to carry the associated repair parts in stock. Information to requisition or otherwise secure the necessary repair parts will be as specified in the Repair Parts, Special Tools List.

f. Normally there will be no deviation from the assigned level of maintenance. In cases of operational necessity, maintenance functions assigned to a higher maintenance level may, on a one-time basis and at the request of the lower maintenance level, be specifically authorized by the maintenance officer of the higher level of maintenance to which the function is assigned. The special tools, equipment, etc. required by the lower level of maintenance to perform this function will be furnished by the maintenance level to which the function is assigned. This transfer of a maintenance function to a lower maintenance level does not relieve the higher maintenance level of the responsibility of the function. The higher level of maintenance has the authority to determine:

- (1) If the lower level is capable of performing the work.

- (2) If the lower level will require assistance or technical supervision and on-site inspection.

- (3) If the authorization will be granted.

g. Maintenance of the US Army Communications and Electronics Materiel Readiness Command equipment will be performed by designated US Army CERCOM personnel.

**h.** Changes to the Maintenance Allocation Chart will be based on continuing evaluation and analysis by responsible technical personnel and on reports received from field activities.

### B-3. DEFINITIONS.

Maintenance functions. Maintenance functions will be limited to and defined as follows:

**a. Inspect.** To determine the serviceability of an item by comparing its physical, mechanical and/or electrical characteristics with established standards through examination.

**b. Test.** To verify serviceability and detect incipient failure by measuring the mechanical or electrical characteristics of an item and comparing those characteristics with prescribed standards.

**c. Service.** Operations required periodically to keep an item in proper operating condition, i.e. to clean (decontaminate), to preserve, to drain, to paint, or to replenish fuel, lubricants, hydraulic fluids, or compressed air supplies.

**d. Adjust.** To maintain, with prescribed limits, by bringing into proper or exact position, or by setting the operating characteristics to specified parameters.

**e. Align.** To adjust specified variable elements of an item to bring about optimum or desired performance.

**f. Calibrate.** To determine and cause corrections to be made or to be adjusted on instruments or test measuring and diagnostic equipment used in precision measurement. Consists of comparisons of two instruments, one of which is a certified standard of known accuracy, to detect and adjust any discrepancy in the accuracy of the instrument being compared.

**g. Install.** The act of emplacing, seating, or fixing into position an item, part, or module (component or assembly) in a manner to allow the proper functioning of an equipment or system.

**h. Replace.** The act of substituting a serviceable like type part, subassembly, or module, (component or assembly) for an unserviceable counterpart.

**i. Repair.** The application of maintenance services or other maintenance actions to restore serviceability to an item by correcting specific damage, fault, malfunctions or failure in a part, subassembly, module (component or assembly), end item, or system.

**j. Overhaul.** That maintenance effort (service/action) necessary to restore an item to a completely serviceable/operational condition as prescribed by maintenance standards (i.e. DMWR) in appropriate technical publications. Overhaul is normally the highest degree of maintenance performed by the Army. Overhaul does not normally return an item to like new condition.

**k. Rebuild.** Consists of those service actions necessary for the restoration of unserviceable equipment to a like new condition in accordance with original manufacturing standards. Rebuild in the highest degree of materiel maintenance applied to Army equipment. The rebuild operation includes the act of returning to zero those age measurements (hours/miles, etc.) considered in classifying Army equipments/components.

### B-4. STANDARD GROUPS.

The standard groupings shown below are used, as applicable, throughout this MAC Maintenance manuals and RPSTLS reflect these standard groupings as individual chapters with sections in each chapter relative to the individual complete systems, subsystems, modules, components, assemblies, or specific parts noted.

### B-5. SYMBOLS.

The letters "AVUM, AVIM and DEPOT" as placed on the Maintenance Allocation Chart indicate the level of maintenance responsible for performing the particular maintenance function based upon assigned skills, tools, and test equipment and time required to accomplish maintenance.

AIRFRAME ITEMS

GROUP NUMBER	DESCRIPTION	GROUP NUMBER	DESCRIPTION
00	Aircraft System	06	Drive Train Systems
01	Aircraft General  Servicing, handling, inspection requirements, lubrication requirements, overhaul and retirement requirements, cleaning, mooring, towing, jacking, hoisting, preservation requirements, weight and balance requirements, spot painting, complete painting, and subassembly painting requirements.	07	Hydraulic and Pneumatic Systems  Pumps, filters, reservoirs, cylinders, valves, servos, motors, starters, and accumulators.
02	Airframe  Fuselage, empennage, pylons, wings mounts (engine and transmission), armor, seats, ramps, decks, and tiedowns.	08	Instrument Systems  Flight instruments, navigation instruments, engine instruments, miscellaneous instruments (i.e. clocks) sending units, panels, and flow meters.
03	Alighting Gear  Landing gear, skids, floats, skis, struts, wheel brakes, and mechanical mechanisms.	09	Electrical Systems  Motors, actuators, regulators, generators, starters, batteries, lighting, caution and warning lights, inverters, fault isolation systems, rotor brakes, and avionics provisions.
04	Power Plant Installation  Removal, installation, cooling systems, air induction, exhaust, oil systems, components, ignition systems, power control, harnesses, carburetors, fuel controls, pumps (engine driven), filters/particle separators, and Quick Change Assemblies (QCA). (See Power Plant Items, figure 2, for more detailed functions.)	10	Fuel Systems  Tanks, cells, filters, pumps, valves, auxiliary fuel systems, and refueling systems.
05	Propellers/Rotors Systems  Propellers, governors, rotors (main and tail), hubs, blades, dampeners, stabilizer bars, and washplates.	11	Flight Controls System  Control sticks, pedals, cables, pulleys, push-pull rods, torque tubes, quadrants, force gradients, control surfaces bellcranks, and trim actuators (mechanical).
		12	Utility Systems  Fire detecting/extinguishing systems, oxygen systems, windshield wiper systems, mirrors, de-ice/anti-ice systems, and LOW G warning system.

GROUP NUMBER	DESCRIPTION	GROUP NUMBER	DESCRIPTION
13	Environmental Control Systems (ECS)  Heaters, air conditioners, defrosters, control mixing valves, and ducts.	16	Mission Equipment  Spraying equipment, stores, racks, armament, reconnaissance, photography pods, and litters.
14	Hoists and Winches  Cargo/rescue hoists, winches, hooks slings, loading systems, and emergency release systems.	17	Emergency Equipment  Ejection seats, canopies, jettison system, portable fire extinguishers, axes, and first aid kits.
15	Auxiliary Power Plants (APP)  Fuel, exhaust, and ducting.	18	Installed Avionics Components  Communications and Navigational Black Boxes

**B-6. WORK TIME.**

In the Maintenance Category column by the listing of a "work time" figure in the appropriate subcolumn(s), levels of maintenance authorized to perform the function are specified. This figure represents the active time (Man-hours) required to perform the specified function. The number of man-hours specified represents the average time required to restore an item (assembly, subassembly, component, module, end item or system) to a serviceable condition under typical field operating conditions. This time includes preparation time, troubleshooting time and quality assurance/quality control time in addition to the time required to perform the specific tasks identified for the maintenance functions authorized.

NOTE: The times indicated in the Maintenance category columns were arrived at by simulated time study. Actual time required to perform the specified

maintenance function on the helicopter may not necessarily be the same. As the -23 Maintenance manual is addressed to AVUM & AVIM maintenance levels the DEPOT column may be disregarded.

**B-7. TOOLS AND TEST EQUIPMENT (SECTION III)**

Special tools, test, and support equipment required to do maintenance functions are listed with a reference number to permit cross-referencing to column 5 in the MAC. In addition, the maintenance category authorized to use the device is listed along with the item National Stock Number and if applicable, the number to aid in identifying the tool/device.

**B-8. REMARKS (SECTION IV)**

Column 6 of the MAC contains alphabetic reference codes which are explained in Section IV of this appendix.

SECTION II. MAINTENANCE ALLOCATION CHART

MAINTENANCE ALLOCATION CHART							
NOMENCLATURE OF END ITEMS							
HELICOPTER, ATTACK, AH-1							
(1) GROUP NUMBER	(2) COMPONENT/ASSEMBLY	(3) MAINTENANCE FUNCTION	(4) MAINTENANCE CATEGORY			(5) TOOLS AND EQUIPMENT	(6) REMARKS
			AVUM	AVIM	DEPOT		
	NOTE						
	The extent of maintenance to be performed by AVUM as indicated in this MAC is governed by the size of the unit and the tools authorized (Refer to paragraph B-1 b(1) a. and b). Specific notes are given to further identify or describe the extent or limit of maintenance to be performed.						
0100	Aircraft System (End Article Vehicle System)						
0100	Aircraft General						
0101	Clean		2.0			100,102	
0102	Moor		1.0			100,102	
0103	Tow		1.0			100,102	
0104	Jack		1.0			100,102	
0105	Hoist		1.0			100,102	
0106	Preservation		1.0			100,102	
0107	Weight and Balance			1.0		102,118	
0108	Spot Paint		1.0			100,102	
0109	Complete Painting				24.0		
0110	Sub-assembly Painting			4.0		102,118	
0111	Service		2.0			100,102	
0200	Airframe	Overhaul				100.0	
0201	Tail boom Assy	Inspect	2.0				
		Replace	2.0			100,102	A
		Repair	4.0			100,102, 103	
				8.0		102,117	
		Overhaul				60.0	

MAINTENANCE ALLOCATION CHART							
NOMENCLATURE OF END ITEMS							
HE ATTACK AH-1							
(1) GROUP NUMBER	(2) COMPONENT/ASSEMBLY	(3) MAINTENANCE FUNCTION	(4) MAINTENANCE CATEGORY			(5) TOOLS AND EQUIPMENT	(6) REMARKS
			AVUM	AVIM	DEPOT		
0202	Fuselage	Inspect Repair	4.0 4.0	8.0		100,102, 103 103,107	A
0202 01	Sheet Metal for Structural Members and Honeycomb Panels not requiring Jigs and Fixtures	Inspect Replace Repair	1.0 2.0 2.0	4.0 4.0		100,102, 103 102,103 100,102, 103 103,117	A A
0202 02	Sheet Metal for Structural Members and Honeycomb Panels that require Jigs and Fixtures	Inspect Replace Repair	1.0		4.0 8.0		
0202 03	Honeycomb Panels	Inspect Replace Repair	1.0 2.0 2.0	4.0		100,102 100,102, 103 103,117	A C
0202 04	Wings	Inspect Replace Repair	1.0 4.0 2.0			100,102 100,102, 103	
0202 05	Transmission Mounts	Inspect Align Replace Repair	1.0 1.0 2.0			100,36, 32 100,102 100,102	
0202 05	Transmission Mount Dampers	Inspect Replace Repair	1.0 2.0	2.0		100,102 102,103	D
0202 06 (02)	Windshield	Inspect Replace Repair	1.0 8.0 1.0	4.0		101,102 101,102 102,103	S D

MAINTENANCE ALLOCATION CHART							
NOMENCLATURE OF END ITEMS							
HE ATTACK, AH-1							
(1) GROUP NUMBER	(2) COMPONENT/ASSEMBLY	(3) MAINTENANCE FUNCTION	(4) MAINTENANCE CATEGORY			(5) TOOLS AND EQUIPMENT	(6) REMARKS
			AVUM	AVIM	DEPOT		
0202 07	Doors	Inspect Adjust Replace Repair	1.0 1.0 3.0 2.0			100,102 100,102 100,102, 103	
0202 07	Window Assembly	Inspect Replace  Repair	1.0 12.0  1.0	4.0		101,102, 103 101,102 102,103	S
0202 07 (02)	Striker Assembly	Inspect Replace Repair	1.0 2.0 2.0			100,102 100,102	
0202 07 (03)	Handle Assembly	Inspect Replace Repair	1.0 1.0 1.0			100,102 100,402	
0202 08	Seat Installation, Pilot and Gunner	Inspect Repair	1.0 2.0			100,102	
0202 08 (01)	Seat Belts and Shoulder Harness	Inspect Replace	1.0 2.0			100,102	
0202 08 (03)	Shoulder Harness Reel	Inspect Replace Repair	1.0 2.0 1.0			100,102 100,102	
0202 08 (03)	Seat Assembly	Inspect Replace Repair	1.0 6.0 4.0			100,102 100,102	
0202 08 (03) (01)	Armor	Inspect Replace  Repair	1.0 2.0  1.0			100,102 100,102	
0202 09	Blanket Assembly, Soundproof	Inspect Replace Repair	1.0 3.0 1.0			100,102 100,102	



MAINTENANCE ALLOCATION CHART							
NOMENCLATURE OF END ITEMS							
HE ATTACK. AH-1							
(1) GROUP NUMBER	(2) COMPONENT/ASSEMBLY	(3) MAINTENANCE FUNCTION	MAINTENANCE CATEGORY			(5) TOOLS AND EQUIPMENT	(6) REMARKS
			AVUM	AVIM	DEPOT		
0202 10	Dock Assembly, Engine	Inspect Align Replace Repair	1.0	2.0 4.0 4.0		102 102 117	
0202 11	Mount Assembly	Inspect Align Replace Repair	1.0 1.0 4.0 2.0	4.0		100 100,102 100,102 102	A
0202 12	Cowl Assmeblies	Inspect Replace Repair	1.0 4.0 4.0			100,102 100,102, 103	
0202 13	Firewall Assembly	Inspect Replace  Repair	1.0 4.0  2.0			100,102, 1 101,102, 1	
0202 14	Heatshield Assembly	Inspect Replace  Repair	1.0 4.0  2.0			101,102, 1 101,102, 1	
0202 15	Mount Installation, Engine						
0202 15 (01)	Support Arms (Brace Rods, Tripod, and B	Inspect Replace Repair	1.0 3.0 2.0			101,102 101,102	
0202 15 (02)	Pillow Block Assembly	Inspect Replace Repair	1.0 1.0 1.0			1 1	
0202 17	Map and Data Case	Inspect Replace	1.0 1.0			1	
0300	Alighting Gear Assembly						
0301	Cross Tubes	Inspect	1.0			1	

MAINTENANCE ALLOCATION CHART							
NOMENCLATURE OF END ITEMS							
HE ATTACK, AH-1							
(1) GROUP NUMBER	(2) COMPONENT/ASSEMBLY	(3) MAINTENANCE FUNCTION	(4) MAINTENANCE CATEGORY			(5) TOOLS AND EQUIPMENT	(6) REMARKS
			AVUM	AVIM	DEPOT		
0301 (Cont)	Cross Tubes (Cont)	Replace	4.0			100,102	A
		Repair	2.0			100,102, 103 102	
0302	Skid Tubes	Inspect	1.0				A
		Replace Repair	4.0 2.0			100,102 100,102 102	
0303	Skid Shoes	Inspect	1.0				A
		Replace Repair	2.0 2.0			100,102 100,102 102,120	
0304	Skid Saddles	Inspect	1.0				
		Replace	2.0			100,102	
0305	Ground Handling Wheels	Inspect	1.0				
		Repair	4.0			100,102 102	
		Service	1.0			100,102	
0305	Pump Assembly	Inspect	1.0				
		Test Replace Repair	1.0 1.0 1.0			100,102 100,102 102,104, 111	
0305 02	Cylinder Assembly	Inspect	1.0				
		Replace Repair	1.0 1.0			100,102 102,111	
0305 03	Wheel Assembly	Inspect	1.0				
		Replace Repair Service	1.0 2.0 1.0			100,102 100,102 100,102	
0306	Skid Installation Tail	Inspect	1.0				
		Replace Repair	2.0 2.0			100,102 100,102	
0400	Power Plant Installation						
0401	Engine (Complete Assembly)	Inspect	2.0				

MAINTENANCE ALLOCATION CHART							
NOMENCLATURE OF END ITEMS							
HELICOPTER, ATTACK, AH-1							
(1) GROUP NUMBER	(2) COMPONENT/ASSEMBLY	(3) MAINTENANCE FUNCTION	(4) MAINTENANCE CATEGORY			(5) TOOL AND EQUIPMENT	(6) REMARKS
			AVUM	AVIM	DEPOT		
0401 (Cont)	<b>Engine (Complete Assembly) (Cont)</b>	Test	4.0	4.0	50.0	100,102 102,108, 118,119	H
		Service Replace	2.0 30.0			100,102 100,102, 108,21, 40	
		Repair	8.0	16.0		100,102, 108	G
		Overhaul				112,118, 119	G
0401 01	<b>Tail Pipe</b>	Inspect	1.0	4.0	100,102 100,102 102,120	A	
		Replace	2.0				
		Repair	1.0				
0401 02	<b>Oil Strainers</b>	Inspect	1.0		100,102		
		Replace	1.0				
0401 03	<b>Droop Compensator</b>	Inspect	1.0		100,102 100,102 100,102		
		Adjust	1.0				
		Replace	2.0				
		Repair	1.0				
0401 04	<b>Actuator, Linear</b>	Inspect	1.0		100,102 100,102		
		Adjust	1.0				
		Replace	2.0				
0401 05	<b>Hoses, Fittings, Couplings, and Tubing</b>	Inspect	1.0		100,102		
		Replace	1.0				
0402 01	<b>Particle Separator</b>	Inspect	1.0	4.0	100,102 100,102 102,103, 112,117, 120		
		Replace	2.0				
		Repair	1.0				

MAINTENANCE ALLOCATION CHART							
NOMENCLATURE OF END ITEMS							
HELICOPTER, ATTACK, AH-1							
(1) GROUP NUMBER	(2) COMPONENT/ASSEMBLY	(3) MAINTENANCE FUNCTION	(4) MAINTENANCE CATEGORY			(5) TOOLS AND EQUIPMENT	(6) REMARKS
			AVUM	AVIM	DEPOT		
0402 02	Centrisep Particle Separator	Inspect	1.0	4.0		100, 102 100, 102 102, 103 112, 117 120	
		Replace	4.0				
	Repair	1.0					
0403	Controls, Power Lever	Inspect	1.0			100,102 100,102	
		Adjust	1.0				
		Replace	2.0				

MAINTENANCE ALLOCATION CHART

NOMENCLATURE OF END ITEMS  
HELICOPTER, ATTACK, AH-1

(1) GROUP NUMBER	(2) COMPONENT/ASSEMBLY	(3) MAINTENANCE FUNCTION	(4) MAINTENANCE CATEGORY			(5) TOOLS AND EQUIPMENT	(6) REMARKS
			AVUM	AVIM	DEPOT		
0403 (Cont)	Controls, Power Lever (Cont)	Repair	4.0			100,102	
0404	Oil Tank, Engine	Inspect	1.0			100,102	
		Test	1.0			100,102	
		Service	1.0			100,102	
		Replace	2.0			100,102	
		Repair	2.0			100,102	
				4.0		120	
0405	Hoses, Fittings, and Tubing	Inspect	1.0				
		Replace	1.0			100,102	
0406	Oil Cooler, Engine	Inspect	1.0				
		Test		4.0		102	
		Replace	2.0			100,102	
		Repair	4.0			100,102	
0407	Oil Cooler Shut-Off Valve	Inspect	1.0				
		Replace	1.0			100,102	
0408	Oil Cooler Blower, Turbine	Inspect	1.0				
		Replace	1.0			100,102	
		Repair		2.0		102,112	
						118,119	
						120	
0409	Chip Detector, Engine	Inspect	0.5				
		Test	1.5			100,102	
		Replace	1.0			100,102	
0410	Valves, Breakaway	Inspect	1.0				
		Replace	2.0			100,102	
0411	External Filter	Inspect				100,102	
		Replace				107	
		Repair					
0412	Oil Separator (Lubriclone)	Inspect				101,102	
		Replace				107	
		Repair					

MAINTENANCE ALLOCATION CHART							
NOMENCLATURE OF END ITEMS HELICOPTER, ATTACK, AH-1							
(1) GROUP NUMBER	(2) COMPONENT/ASSEMBLY	(3) MAINTENANCE FUNCTION	(4) MAINTENANCE CATEGORY			(5) TOOLS AND EQUIPMENT	(6) REMARKS
			AVUM	AVIM	DEPOT		
0500	Rotor Systems						
0501	Pylon Assembly, External Components	Inspect	1.0				
		Replace	2.0			100,102	
		Repair	2.0			100,102 103	
0502	Hub and Blade Assy, Main Rotor	Inspect	1.0				
		Adjust	2.0			101,102 44,51	

MAINTENANCE ALLOCATION CHART							
NOMENCLATURE OF END ITEMS							
HE ATTACK, AH-1							
(1) GROUP NUMBER	(2) COMPONENT/ASSEMBLY	(3) MAINTENANCE FUNCTION	(4) MAINTENANCE CATEGORY			(5) TOOLS AND EQUIPMENT	(6) REMARKS
			AVUM	AVIM	DEPOT		
0502 (Cont)	Hub and Blade Assy, Main Rotor (Cont)	Align	3.0			101,102, 26,30,31, 34,41,59	
		Replace	4.0			101,102, 13,14, 21,59	
0502 01	Hub Assembly	Inspect	1.0			101,102,	J
		Align	2.0			14,21,59	
		Replace	4.0			101,102, 109,13,	
		Repair	2.0	4.0		14,21,59 101,102	
		Overhaul			40.0	102,105, 109,113, 114,45, 47	
0502 01 (01)	Drag Brace Assembly	Inspect	1.0			101,102,	
		Replace	1.0			109	
		Repair	2.0			101,102, 109	
0502 01 (02)	Grip Assembly	Inspect	1.0			102,118	
		Replace		3.0		102,109,	
		Repair		2.0		112,113, 118	
3502 01 (03)	Housing Assembly	Inspect		1.0		102,109	
		Replace		2.0		102,109,	
		Repair		2.0		112,113, 118	
0502 01 (04)	Defector, Sand	Inspect	0.5			100,102,	
		Replace	1.0			109	
0502 01 (05)	Pitch Horn Assembly	Inspect	1.0	1.0		101,102	D
		Replace		2.0		101,102	
		Repair	1.0			101,102	

MAINTENANCE ALLOCATION CHART

NOMENCLATURE OF END ITEMS

HELICOPTER, ATTACK, AH-1

(1) GROUP NUMBER	(2) COMPONENT/ASSEMBLY	(3) MAINTENANCE FUNCTION	(4) MAINTENANCE CATEGORY			(5) TOOLS AND EQUIPMENT	(6) REMARKS
			AVUM	AVIM	DEPOT		
0502 01 (05) (Cont)	Pitch Horn Assembly (Cont)			2.0		102, 109, 112, 113, 118	
0502 01 (06)	Extension Assembly	Inspect	1.0				
		Replace		4.0		102, 109	
		Repair	1.0			101, 102 102, 109, 112, 113, 118	
0502 01 (07)	Strap Assembly Tension	Inspect		1.0			
		Replace			4.0		102, 112, 113, 118
0502 01 (08)	Bolt Assembly, Blade Retention	Inspect	1.0				
		Replace	1.0			101, 102, 109	
		Repair	1.0			101, 102, 109	
0502 01 (09)	Yoke Assembly	Inspect	1.0				
		Replace			4.0		
		Repair	1.0			101, 102	D
				2.0		102, 109, 112, 113	
0502 01 (10)	Trunnion Assembly	Inspect	1.0	1.0			
		Replace			3.0		
		Repair	1.0			101, 102	D
				2.0		102, 109, 112, 113, 118	
0502 01 (11)	Housing Assembly Trunnion	Inspect	1.0	1.0			
		Replace			3.0	102, 109	
		Repair	1.0			101, 102, 109	D
				2.0		102, 104	



MAINTENANCE ALLOCATION CHART

NOMENCLATURE OF END ITEMS

HELICOPTER, ATTACK, AH-1

(1) GROUP NUMBER	(2) COMPONENT/ASSEMBLY	(3) MAINTENANCE FUNCTION	(4) MAINTENANCE CATEGORY			(5) TOOLS AND EQUIPMENT	(6) REMARKS
			AVUM	AVIM	DEPOT		
0502 01 (12)	Strap, Hub Moment	Inspect	1.0	1.0			
		Replace	1.0	1.0		102	
		Repair					
0502 01 (13)	Plate, Hub Moment	Inspect	1.0	1.0			
		Replace	1.0	1.0		102	
		Repair					
0502 02	Blade Assembly, Main Rotor	Inspect	1.0			101, 41, 51	
		Adjust	1.0			101, 102	
		Replace	3.0			109	



MAINTENANCE ALLOCATION CHART							
NOMENCLATURE OF END ITEMS							
HE ATTACK, AH-1							
(1) GROW NUMBER	(2) COMPONENT/ASSEMBLY	(3) MAINTENANCE FUNCTION	(4) MAINTENANCE CATEGORY			(5) TOOLS AND EQUIPMENT	(6) REMARKS
			AVUM	AVIM	DEPOT		
0502 02 (Cont)	Blade Assembly, Main Rotor (Cont)	Repair	1.0			101,102, 109 121	
0503	Scissors and Sleeve Assembly	Overhaul		12.0	60.0		
		Inspect	1.0				
		Replace	4.0			101,102, 109	
		Repair		4.0		101,102 102,109, 112,118, 10,110,27 28,35,87, 88	
0503 01	Link Assembly, Scissors	Overhaul			35.2		
		Inspect	1.0	1.0		101,102, 109	
		Replace		1.0			
		Repair		2.0		101,102 102,109, 112	D
0503 02	Scissors Assembly	Inspect	1.0	1.0		101,102, 109	
		Replace		2.0			
		Repair		4.0		101,102 102,109, 112	D
0503 03	Hub Assembly	Inspect	1.0	1.0			
		Replace		4.0			
		Repair		2.0		101,102 102,109, 113	D
0503 04	Sleeve, Collective	Inspect	1.0	1.0			
		Replace		4.0			
		Repair		2.0		101,109	D
0504	Swashplate and Support Assembly	Inspect	1.0				
		Replace	4.0			101,102, 109	
		Repair	2.0	4.0		101,102 102,109	D
		Overhaul			40.0		

MAINTENANCE ALLOCATION CHART							
NOMENCLATURE OF END ITEMS							
HELICOPTER, ATTACK, AH-1							
(1) GROUP NUMBER	(2) COMPONENT/ASSEMBLY	(3) MAINTENANCE FUNCTION	(4) MAINTENANCE CATEGORY			(5) TOOLS AND EQUIPMENT	(6) REMARKS
			AVUM	AVIM	DEPOT		
0505	Rotor Installation, Tail	Inspect Replace Repair	1.0 4.0 2.0			101,102, 109 100,102, 109	
0505 01	Link Assembly	Inspect Replace Repair	1.0 1.0 1.0			100,102, 109 100,102, 109	
0505 02	Crosshead	Inspect Replace Repair	1.0 2.0 2.0			100,102, 109 100,102, 109	
0505 03	Hub and Blade Assembly	Inspect Adjust Align Replace Repair	1.0 1.0 1.0 4.0 2.0			100,102 100,102, 109,82 100,102 109,90 100,102, 109	I J
0505 03 (01)	Blade Assembly	Inspect Replace Repair	1.0 2.0 1.0		4.0	100,102 100,102 102,109	
0505 03 (02)	Hub Assembly	Inspect Service Adjust Replace Repair	1.0 1.0 2.0 4.0 1.0		4.0	100,102 100,102 100,102, 109 100,102, 109 102,109	

MAINTENANCE ALLOCATION CHART							
NOMENCLATURE OF END ITEMS							
HELICOPTER, ATTACK, AH-1							
(1) GROUP NUMBER	(2) COMPONENT/ASSEMBLY	(3) MAINTENANCE FUNCTION	(4) MAINTENANCE CATEGORY			(5) TOOLS AND EQUIPMENT	(6) REMARKS
			AVUM	AVIM	DEPOT		
0600	Drive Train System						
0601	Intermediate and Tail Rotor Drive Gearboxes	Inspect	1.0				
		Service	1.0			100,102	
		Replace	4.5			100,102	
		Repair	1.5			100,102	
		Overhaul			22.5		
0601	Intermediate and Tail Rotor Drive Gearbox Quills	Inspect	1.5				
		Service	1.5			100,102	
		Replace	2.0			101,102, 23,25,24, 38,39,58	T
		Repair	1.5			23,24,25, 38,39,58	
		Overhaul			5.0		
0602	Tail Rotor Drive Shaft	Inspect	1.0				
		Replace	3.4			100,102	
		Repair	1.5			100,102 102,109	T
					2.0		
0603	Tail Rotor Drive Shaft Hanger Assemblies	Inspect					
		Service	1.0			102	
		Align	4.5			100,102	
		Replace	2.5			100,102	
		Repair	1.5			100,102, 109	M
				3.0		113	
0604	Main Transmission	Inspect	1.0				
		Service	2.0			102	
		Replace	6.5			101,105, 17	
		Repair	1.2			101,105, 17	
				2.5		102,105, 109,17	
		Overhaul			82.5		
0604	Drive Quill Assemblies	Inspect	1.5				
		Service	2.5			100,102	
		Replace	4.5			101,109, 24	

MAINTENANCE ALLOCATION CHART

NOMENCLATURE OF END ITEMS

HELICOPTER, ATTACK, AH-1

(1) GROUP NUMBER	(2) COMPONENT/ASSEMBLY	(3) MAINTENANCE FUNCTION	(4) MAINTENANCE CATEGORY			(5) TOOLS AND EQUIPMENT	(6) REMARKS
			AVUM	AVIM	DEPOT		
0604 (Cont)	Drive Quill Assemblies (Cont)	Repair		2.5		101,109, 24,46	M
		Overhaul			5.5		
0605	Main Drive Shaft (Engine to Transmission)	Inspect	1.0			100,102 100,109, 32,36 100,102, 109 100,22,33	
		Service	1.5				
		Align	1.0				
		Replace	4.5				
		Repair	1.5			6.5	
		Overhaul					
0606	Lines, Manifolds and Fittings	Inspect	1.0			100,102 100,102	
		Replace	2.0				
		Repair	1.0				
0607	Sight Gages	Inspect	0.5			100,102 100,102	
		Replace	0.5				
		Repair	0.5				
0608	Oil Jets	Inspect	1.0			100,102 100,102	
		Replace	1.5				
		Repair	1.0				
0609	Filters, Filter Housings and Screens	Inspect	1.0			100,102 100,102	
		Replace	2.5				
		Repair	1.5				
0610	Transmission Oil Cooler Assembly	Inspect	1.0			100,102 100,102	
		Replace	1.0				
		Repair	1.0				
0611	Bypass Valve Assembly	Inspect	1.0			100,102 52,53, 54,55	
		Replace	1.5				
		Repair		2.0			
0612	Oil Pump	Inspect	1.0			100,102 100,102 102	
		Test		1.0			
		Replace	2.5				
		Repair		1.5			
		Overhaul			4.5		

MAINTENANCE ALLOCATION CHART							
NOMENCLATURE OF END ITEMS HELICOPTER, ATTACK, AH-1							
(1) GROUP NUMBER	(2) COMPONENT/ASSEMBLY	(3) MAINTENANC E FUNCTION	(4) MAINTENANCE CATEGORY			(5) TOOLS AND EQUIPMENT	(6) REMARK S
			AVUM	AVIM	DEPOT		
0613	Mast Assembly	Inspect	1.0			101,102, 13,14 101,109 113,12,91	
		Replace	5.6				
		Repair	1.0				
		Overhaul			16.5		
0613 01	Support, Hub Moment	Inspect	1.0		1.0	102	
		Replace	1.0		1.0		
0613 02	Spring, Hub Moment	Inspect	0.5			102	
		Replace	0.5				
0614	Friction Collect	Inspect	0.5			101,109, 89 101,109 101,109	
		Adjust	6.5				
		Replace Repair	6.5 1.0				
0615	Debris Monitor	Inspect	1.0			100,102 107	
		Test	1.0				
		Replace Repair	2.0	2.0			
0700	Hydraulic and Pneumatic Systems						
0701	Pumps	Inspect	1.0			100,102 100,102, 104	
		Replace	2.5				
		Repair	1.5				
		Overhaul			12.0		
0702	Reservoirs	Inspect	1.0			100,102 100,102, 104 100,102, 104	
		Service	1.0				
		Replace	2.5				
		Repair	1.5				
0703	Valves	Inspect	1.0			101,102, 104 104,111	
		Replace	1.5				
		Repair		2.0			

MAINTENANCE ALLOCATION CHART							
NOMENCLATURE OF END ITEMS							
HELICOPTER, ATTACK, AH-1							
1) GROUP NUMBER	2) COMPONENT/ASSEMBLY	3) MAINTENANCE FUNCTION	4) MAINTENANCE CATEGORY			5) TOOLS AND EQUIPMENT	6) REMARKS
			AVUM	AVIM	DEPOT		
0705	Solenoid Valve	Inspect	1.5				
		Replace	1.5			101,102, 104	
		Repair		1.0		102,104, 111	
0706	Hose, Tubing, and Fittings	Inspect	1.0				
		Replace	1.5			102,104	
0707	Hydraulic Module	Inspect	1.5				
		Replace	2.4			101,102, 104	
		Repair		1.5		102,104, 111	
		Overhaul		4.6			V
0708	Hydraulic Servo Cylinders	Inspect	1.5				
		Replace	2.0			100,104, 23	
		Repair		1.5		102,104, 111	
0709	Hydraulic Accumulator	Inspect	1.0				
		Test		0.5		104,111	
		Service	0.5			100,104	
		Replace	2.1			100,104	
		Repair		1.0		104,111	
0710	Accumulator Air Press Gage	Inspect	1.0				
		Replace	1.0			100,104	
0711	SCAS Servo Actuators	Inspect	1.5				
		Test		2.1		104,111	
		Replace	2.5			100,104	
		Repair		3.5		104,111	
		Overhaul			9.5		



MAINTENANCE ALLOCATION CHART							
NOMENCLATURE OF END ITEMS							
HE ATTACK, AH-1							
(1) GROUP NUMBER	(2) COMPONENT/ASSEMBLY	(3) MAINTENANCE FUNCTION	(4) MAINTENANCE CATEGORY			(5) TOOLS AND EQUIPMENT	(6) REMARKS
			AVUM	AVIM	DEPOT		
0800	Instrument Systems						
0801	Instrument Panels	Inspect Replace Repair	2.5	3.5 2.1		106 106	
0801 01	Miscellaneous Instruments						
0801	Clock	Inspect Replace Overhaul	1.5 1.5		3.0	100,106	
0801 0102	Free Air Temperature Gage	Inspect Test Replace	1.0 1.0 1.0			101,106 101,106	
0801 0103	Volt, Load and Ammeter	Inspect Adjust Replace	1.0 1.0 1.5			100,107 100,107	
0801 02	Fuel Quantity Indicator System						
0801 0201	Fuel Quantity Indicator and Amplifier	Inspect Test Adjust Replace Overhaul	1.0 2.5	2.5 2.5	8.0	101,110 110 106	U
0801 0202	Tank Sensor, Probes and Units	Inspect Test Replace		1.0 1.5 2.5		110 106	
0801 03	Flight Instruments						
0801 0301	Vertical Velocity Indicator	Inspect Test Replace Overhaul	0.5 1.0 1.5		8.0	100,106 100,106	
0801 0302	Standby Compass	Inspect Adjust Replace	0.5 0.5 1.0			100,106 100,106	

MAINTENANCE ALLOCATION CHART							
NOMENCLATURE OF END ITEMS							
HELICOPTER, ATTACK, AH-1							
(1) GROUP NUMBER	(2) COMPONENT/ASSEMBLY	(3) MAINTENANCE FUNCTION	(4) MAINTENANCE CATEGORY			(5) TOOLS AND EQUIPMENT	(6) REMARKS
			AVUM	AVIM	DEPOT		
0801 0303	Airspeed Indicator	Inspect	1.0				
		Test	1.0			100,106	
		Replace	2.0			100,106	
		Overhaul			7.5		
0801 0304	Altimeter	Inspect	1.0				
		Test	1.0			100,106	
		Replace	2.0			100,106	
		Overhaul			9.5		
0801 0305	Attitude Indicator	Inspect	0.5				
		Replace	0.5			100,106	
		Overhaul			8.5		
0801 0306	Turn and Slip Indicator	Inspect	0.5				
		Replace	0.5			100,106	
		Overhaul			8.5		
0801 0307	Pitot System	Inspect	0.5				
		Test	1.5			100,106	
		Calibrate		2.0		110	
		Repair	1.5			100,106	
0801 04	Engine Instruments						
0801 0401	Engine and Rotor Tachometer	Inspect	1.0				
		Test		2.0		110	
		Replace	1.0			100,106	
		Overhaul			11.5		
0801 0402	Turbine Gas, Temperature	Inspect	0.5				
		Test		1.5		110	
		Calibrate		2.0		110	
		Repair	1.5			100,106	
		Overhaul			6.5		
0801 0403	Engine Oil Temperature Gage	Inspect	0.5				
		Replace	1.0			100,106	
		Overhaul			4.0		

MAINTENANCE ALLOCATION CHART							
NOMENCLATURE OF END ITEMS							
HE ATTACK, AH-1							
(1) GROUP NUMBER	(2) COMPONENT/ASSEMBLY	(3) MAINTENANCE FUNCTION	(4) MAINTENANCE CATEGORY			(5) TOOLS AND EQUIPMENT	(6) REMARKS
			AVUM	AVIM	DEPOT		
0801 0404	Engine Oil Pressure Transmitter and Indicator	Inspect Replace Overhaul	0.5 1.5		3.5	100,106	
0801 0405	Fuel Pressure Indicator and Transmitter	Inspect Test Replace Overhaul	0.5 1.0	1.0	2.5	110 100,106	
0801 0406	Torquemeter and Transmitter	Inspect Replace Overhaul	0.5 1.0		2.5	100,106	
0801	Tachometer, Generators	Inspect Replace	0.5 1.0			100,106	
0801 05	Engine Instruments						
0801 0501	Gas Producer Tachometer	Inspect Test Replace Overhaul	0.5 1.5	1.0	3.0	110 100,106	
0801 06	Transmission Instruments						
0801 0601	Oil Temperature Gage	Inspect Replace Overhaul	0.5 0.5		3.5	100,106	
0801 0602	Oil Pressure Gage and Transmitter	Inspect Replace Overhaul	0.5 1.5		2.5	100,106	
0801 0603	Temperature Bulbs	Inspect Test Replace	0.5 0.5	0.5		110 100,106	

MAINTENANCE ALLOCATION CHART							
NOMENCLATURE OF END ITEMS							
HELICOPTER, ATTACK, AH-1							
(1) GROUP NUMBER	(2) COMPONENT/ASSEMBLY	(3) MAINTENANCE FUNCTION	(4) MAINTENANCE CATEGORY			(5) TOOLS AND EQUIPMENT	(6) REMARKS
			AVUM	AVIM	DEPOT		
0900	Electrical Systems						
0901	Inverters	Inspect Replace Repair	0.5 1.5 2.0			100,107 100,107	N
0902	Relays, Rheostats Switches, Circuit Breakers, Plugs, Leads, Connectors, Conduits, Receptacles, Shunts, and Circuit Boards	Inspect Test Replace Repair	0.5 1.0	0.5 0.5		110 100,107 107,110	
0903	Wiring	Inspect Test Replace Repair	4.5 8.5 1.0 10.5			100,107 100,107 100,107 100,107	
0904	Regulator	Inspect Adjust Replace Overhaul	0.5 0.5 1.0		8.0	100,107 100,107	
0905	Battery	Inspect Test Service Replace Repair	0.5 1.0			100,102	O O O
0906	Starter Generator	Inspect Test Replace Repair	1.5 2.0	2.0 2.5		107,110 100,107 107,110	P
0907	Cooling Blower	Inspect Replace Repair Overhaul	0.5 1.5 0.5		10.5	100,107 100,107	
0908	Lights	Inspect Replace	0.5 0.5			100,107	

MAINTENANCE ALLOCATION CHART							
NOMENCLATURE OF END ITEMS HELICOPTER, ATTACK, AH-1							
(1) GROUP NUMBER	(2) COMPONENT/ASSEMBLY	(3) MAINTENANCE FUNCTION	(4) MAINTENANCE CATEGORY			(5) TOOLS AND EQUIPMENT	(6) REMARKS
			AVUM	AVIM	DEPOT		
0909	Alternator	Inspect	0.5			100,107 100,107	
		Replace	2.5				
		Repair	1.5				
		Overhaul			8.0		
0910	Navigation, instrument, Interior Cabin, Anti-Collision, and Flasher Units	Inspect	1.0			100,102 100,102	
		Replace	1.5				
		Repair	1.5				
0910 01	GPS Trimpack	Inspect	0.5				R R R
		Test	0.5				
		Replace	0.5				
0911	Search Light Assembly	Repair		3.0			
		Inspect	0.5			100,107 100,107	
		Replace	0.5				
Repair	1.5						
		Overhaul			5.5		
0912	Caution Panels	Inspect	0.5			107,100 100,107 107,110	
		Test	0.5				
		Replace	1.0				
		Repair	1.5	1.0			
0913	RPM Warning Control Box	Inspect	1.5			100,106 100,106 106,110	
		Adjust	3.5				
		Replace	1.5				
		Repair		0.5			
		Overhaul			9.5		
0914	Chip Detector System ODDS Power Module	Inspect	0.5			100,107	
		Replace	1.0				
1000	Fuel System						
1001	Main Fuel Tanks, both crashworthy and non-crashworthy	Inspect	1.5			100,102 102 102,117	
		Service	0.5				
		Replace, Repair		8.5 6.5			
1002	Fuel Low Level Warning system	Inspect	0.5			100,102 100,102	
		Test		2.0			
		Replace		4.5			
1003	Boost Pumps	Inspect	1.5			101,102	
		Replace	2.0				
		Repair		5.5			

MAINTENANCE ALLOCATION CHART

NOMENCLATURE OF END ITEMS  
HELICOPTER, ATTACK, AH-1

(1) GROUP NUMBER	(2) COMPONENT/ASSEMBLY	(3) MAINTENANCE FUNCTION	(4) MAINTENANCE CATEGORY			(5) TOOLS AND EQUIPMENT	(6) REMARKS
			AVUM	AVIM	DEPOT		
1004	Valves and Fittings	Inspect Replace	0.5 1.0			100,102	
1005	Filter Assembly	Inspect Replace Repair	0.5 1.5 0.5			100,102 100,102 100,102	
1006	Hoses, Tubing and Filter Caps	Inspect Replace	0.5 1.5			100,102	
1100	Flight Control Systems						
1101	Main Rotor Control Tubes and Rod Ends	Inspect Adjust Replace Repair	3.5 2.5 4.0 2.5			100,102 101,102 101,102	
1102	Force Gradient Assembly	Inspect Adjust Replace Repair	0.5 3.0 1.0	2.0		100,102 101,102 102	
1103	Control Stick (Collective and Cyclic)	Inspect Adjust Replace Repair	1.0 2.0 2.0 2.0	2.5 4.0		100,102 102,46 102,107	
1104	Synchronized Elevator	Inspect Adjust Replace Repair	2.0 3.0 4.0 2.0			100,102 101,102 101,103	
1105	Magnetic Brake	Inspect Adjust Replace Repair	0.5 0.5 1.0	4.0		100,102 101,102	
1106	Collective and Cyclic Linkage	Inspect Adjust Replace Repair	2.0 5.0 2.0 1.0			100,102 101,102 101,102	
1107	Tail Rotor Pedal Assy Linkage	Inspect Adjust	3.0 5.0			100,102	

MAINTENANCE ALLOCATION CHART							
NOMENCLATURE OF END ITEMS							
HELICOPTER, ATTACK, AH-1							
(1) GROUP NUMBER	(2) COMPONENT/ASSEMBLY	(3) MAINTENANCE FUNCTION	(4) MAINTENANCE CATEGORY			(5) TOOLS AND EQUIPMENT	(6) REMARKS
			AVUM	AVIM	DEPOT		
1107 (Cont)	Tail Rotor Pedal Assy (Cent)	Replace	8.0			101,102	
		Repair	3.0			101,102	
1108	Pedal Adjusting Assembly	Inspect	1.5				
		Adjust	1.5			100,102	
		Replace	2.5			101,102	
		Repair	2.0			101,102	
1109	Tail Rotor Pitch Control Linkage	Inspect	1.5				
		Adjust	2.0			100,102	
		Replace	2.5			101,102	
		Repair	1.0			101,102	
1110	Tail Rotor Pitch Control Mechanism	Inspect	2.0			100,102	
		Adjust	3.0			101,102	
		Replace	2.0			101,102	
		Repair	2.0			101,102	
1111	Tail Rotor Pitch Change Rods and Links	Inspect	1.0				
		Adjust	1.5			100,102	
		Replace	2.0			101,102	
		Repair	1.0			101,102	
1112	Stabilization Equipment						
1112 01	Control Panel	Inspect	0.5				
		Replace					F
		Repair					F
1112 02	Control Box	Inspect	0.2				
		Test					N
		Replace Repair		0.5		100,102	N
1112 03	Solenoid Valves, Hoses, Connectors	Inspect	1.0				
		Replace	1.5			100,102	
1112 04	Transducers	Inspect	0.5				
		Replace	1.0			100,102	

MAINTENANCE ALLOCATION CHART							
NOMENCLATURE OF END ITEMS							
HELICOPTER, ATTACK, AH-1							
(1) GROUP NUMBER	(2) COMPONENT/ASSEMBLY	(3) MAINTENANCE FUNCTION	(4) MAINTENANCE CATEGORY			(5) TOOLS AND EQUIPMENT	(6) REMARKS
			AVUM	AVIM	DEPOT		
1200	Utility Systems						
1201	Fire Detector System - Engine	Inspect Replace	0.5 1.5			100,102	
1202	Anti-king, System	Inspect Replace	0.5 1.5			100,102	
1203 01	Low G Warning System 8A10 Assembly	Inspect Test Test Replace	0.5 1.0 0.5 0.5			100,102	
1203 02	Accelerometer 8A11	Inspect Test Replace	0.5 0.5 0.5			100,102	
1203 03	Low G Warning Light/switch 8DS25	Inspect Test Replace	0.5 0.5 0.5			100,102	
1203 04	Counter 8M1	Inspect Test Replace	0.5 0.5 0.5			100,102	
1203 05	Relay, 8K1, 8K2	Inspect Test Replace	0.5 0.5 0.5			100, 102	
1203 06	Wiring	Inspect Test Replace	0.5 0.5 0.5			100,102	
1300	Environmental Control System (ECS)						
1301	Bleed Air Heater System	Inspect Repair	0.5 2.0			100,102	
1302	Control Valves	Inspect Replace Repair Test	1.5 2.5			100,102 107, 110 107, 110	



MAINTENANCE ALLOCATION CHART							
NOMENCLATURE OF END ITEMS							
HELICOPTER, ATTACK, AH-1							
(1) GROUP NUMBER	(2) COMPONENT/ASSEMBLY	(3) MAINTENANCE FUNCTION	(4) MAINTENANCE CATEGORY			(5) TOOLS AND EQUIPMENT	(6) REMARKS
			AVUM	AVIM	DEPOT		
1303	Vent Blower	Inspect	2.0				
		Replace	2.0			100, 102	
		Repair	2.0			100, 102	
1304	Ventilating Ducts, Inlet Door, and Control	Inspect	1.0				
		Adjust	1.0			100, 102	
		Replace	1.5			100, 102	
		Repair	1.0			100, 102, 103	
1305	Environmental Control Unit	Inspect	1.0				
		Service	1.0			100, 102	
		Replace	3.0			101, 102	
		Repair	1.0			101, 102	
		Overhaul			45.0		
1306	Heater Exchanger	Inspect	0.5				
		Replace	2.0			100, 102	
		Repair	2.0			100, 102	
1307	Temperature Control/ Sensor	Inspect	0.5				
		Replace	1.0			100, 107	
		Repair		2.0		107, 110	
		Overhaul			10.0		



MAINTENANCE ALLOCATION CHART							
NOMENCLATURE OF END ITEMS							
HE ATTACK, AH-1							
(1) GROUP NUMBER	(2) COMPONENT/ASSEMBLY	(3) MAINTENANCE FUNCTION	(4) MAINTENANCE CATEGORY			(5) TOOLS AND EQUIPMENT	(6) REMARKS
			AVUM	AVIM	DEPOT		
1308	Temperature Control/ Valve	Inspect Replace Repair Overhaul	0.5 1.5 2.0		10.0	100,107 100,107	
1308 01	Torque Motor	Inspect Replace Overhaul	0.5 1.0		8.0	100,102	
1308 02	Turbine Assembly	Inspect Replace Overhaul	0.5 7.0		18.0	101,102	
1308 03	Nozzles, Cockpit Outlet	Inspect Replace	0.5 1.0			100,102	
1309	Pressure Regulating and Shut-off Valve	Inspect Test Replace Overhaul	0.5 2.0	1.5	12.0	110,107 100107	
1309 01	Solenoid Valve	Inspect Replace Overhaul	0.2 0.5		6.0	100,107	
1309 02	Pressure Relief Valve	Inspect Replace	0.2 0.5			100,107	
1309 03	Temperature Selector	Inspect Replace	0.5 0.5			100,102	
1310	Rain Removal System	Inspect Replace Repair	1.5 3.0 2.0			100,102 100,102	
1311	Hot Air Valve	Inspect Replace Overhaul	2.0 1.0		8.0	100,102	

MAINTENANCE ALLOCATION CHART								
NOMENCLATURE OF END ITEMS								
HELICOPTER, ATTACH, AH-1								
(1) GROUP NUMBER	(2) COMPONENT/ASSEMBLY	(3) MAINTENANCE FUNCTION	(4) MAINTENANCE CATEGORY			(5) TOOLS AND EQUIPMENT	(6) REMARKS	
			AVUM	AVIM	DEPOT			
1400	Hoist and Winches (Not Applicable)							
1500	Auxiliary Power Plants (APP) (Not applicable)							
1600	Mission Equipment Armament (Aircraft Components)							
				NOTE				
			Organizational maintenance of the armament system will be performed by Aircraft Armament Sub-system Repairmen.					
1601	Turret Weapons System							
1601 01	Pilot Gun Sight	Inspect Replace	0.5				R	
1601 02	Pilot Gunner's Control Panels	Inspect Test Replace Repair	0.5				R R R R	
1602	External Stores							
1601 01	Emergency Jettison System	Inspect Adjust Replace Repair Test	1.0 0.5 7.5 3.0 1.5			101,102 101,102 101,102 101,102		
1602 02	Ejector Rack	Inspect Adjust Replace Repair Overhaul	0.5 5.0 2.0 1.0		12.0	100,102 100,102 100,102		
1602 03	Grenade Dispenser	Inspect Replace	0.5 1.0			100,102		

MAINTENANCE ALLOCATION CHART							
NOMENCLATURE OF END ITEMS							
HELICOPTER, ATTACK, AH-1							
(1) GROUP NUMBER	(2) COMPONENT/ASSEMBLY	(3) MAINTENANCE FUNCTION	(4) MAINTENANCE CATEGORY			(5) TOOLS AND EQUIPMENT	(6) REMARKS
			AVUM	AVIM	DEPOT		
1602 04	Accelerometer Resolver	Inspect Adjust Replace Repair	0.2 0.5 0.5 8.0			100,102 100,102 101,102	
1602 05	Servo-electronic Control Unit	Inspect Adjust Replace Repair Overhaul	0.5 1.0 2.0 1.0	2.0	24.0	101,107 101,107 101,107	
1602 06	Hydraulic Power Cylinder	Inspect Replace Repair Overhaul	0.5 1.0 3.0		16.0	101,102 101,104	
1602 07	AIM-1/EXL Laser	Inspect Replace Repair	0.5 0.5		8.0	102	
1700	Emergency Equipment						
1701	Canopy Removal System	Inspect Replace Repair	0.5	5.0 10.0		102 102	
1800	Installed Avionics Components						
NOTE							
TM 11-1520-221-30 contains maintenance instructions for avionics.							

## SECTION III. TOOLS AND TEST EQUIPMENT REQUIREMENTS

TOOL OR TEST MAINTENANCE EQUIPMENT	CATEGORY	NOMENCLATURE	NATIONAL/NATO STOCK NUMBER	TOOL NO.
5	O	Bit, Screwdriver	5120-00-863-4941	HTS-6
6	O	Socket, Adapter	5120-00-937-8481	HTS-10
10	F	Stand Assy, Scissors and Sleeve		PD 1468
11	F	Socket, Wrench, Face Spanner		PD1469
12	O	Socket, Splined	5120-00-619-9773	PD 2658
13	O	Socket, Mast Nut	5120-00-619-9779	PD 2659
14	O	Adapter, Reaction	5120-00-619-9776	PD 2660
17	F	Transmission Adapter	4920-00-676-2307	SWE13852-40
21	O	Sling, Aircraft Maint	1730-00-099-8099	T100220
22	O	Wrench, Transmission	4920-00-797-3672	T101306
23	O	Wrench, Tail Rotor	4920-00-718-6533	T101307
24	O	Jack Screw Set	4920-00-710-7946	T101308
25	O	Jack Screw Set	4920-00-765-4410	T101338
26	O	Build Up Bench	4920-00-678-5431	T101356
27	F	Support Scissors and Sleeve	4920-00-786-1756	T101369
28	F	Ram Adapter, Scissors & Sleeve	4920-00-713-5555	T101382
30	O	Scope Assy Blade Alignment	4920-00-718-6674	T101401
31	O	Socket, Wrench, Face Spanner	5120-00-044-1426	T101414
32	O	Tool Set, Alignment	5120-00-894-6540	T101419
33	O	Fixture, Holding Shaft	4920-00-876-0103	T101420

TOOL OR TEST EQUIPMENT	MAINTENANCE CATEGORY	NOMENCLATURE	NATIONAL/NATO STOCK NUMBER	TOOL NO.
34	O	Plate	4920-00-898-0015	T101421
35	O	Bar, Bearing Removal	4920-00-876-0102	T101424
36	O	Jack Set	4920-00-805-5123	T101440
38	O	Socket, Wrench, Face, Spanner	5120-00-967-7699	T101449
39	O	Plate Assy	4920-00-967-7651	T101455
40	O	Hoisting Unit, Engine	1730-00-073-9258	T101452
41	O	Support, Main Rotor	4920-00-907-7649	T101467
44	O	Bending Gage, Trim	5210-00-919-2374	T101485
45	O	Installation Tool, Seal	5120-00-925-5085	T101487
46	F	Wrench, Input Quill	5120-00-932-3670	T101488
47	F	Puller, Bearing	5120-00-999-5306	T101491
50	O	Fixture, Rigging, Stick Cycle	4920-00-848-4930	T101524
51	O	Tab Bender, Main Rotor Blade	5120-00-844-7757	T101525
52	O	Fixture, Holding	4920-00-176-3708	T101549
53	O	Disassembly Tool, Valve	5120-00-176-3698	T101550
54	O	Puller, plug	5120-00-400-7724	T101551
55	O	Tool Set, Plunger Assy	5180-00-176-3701	T101553
57	O	Staking Tool	5120-00-409-9524	T101577
58	O	Wrench, Spanner	5120-00-412-7401	T101600
59	O	Lock Grip, Main Rotor	5120-00-451-2956	T101864
60	F	Sealing Tool, Pylon Damper	4920-00-423-5239	1570-EG-00
82	O	Plate Adapter	4920-00-437-5112	7HELO74
87	F	Socket Collective Sleeve Bearing		PD 1470
88	F	Extension, Socket Wrench	5120-00-033-2112	PD 1471

TOOL OR TEST EQUIPMENT	MAINTENANCE CATEGORY	NOMENCLATURE	NATIONAL/NATO STOCK NUMBER	TOOL NO.
89	O	Scale Dial Indicator	6670-00-246-0347	AAAS133
90	O	Crowfoot Attachment	5120-00-184-8413	GGGW641
91	F	Socket, Splined Reaction	5120-00-619-9774	PD 2657
92	O	Key Socket Head	5120-01-016-5635	GGGK275
100	O	Tool Set, Avum, Set No. 1	4920-00-159-8727	
101	O	Tool Set, AVUM, Set No. 2	4920-00-567-0476	
102	O	Tool Kit, Aircraft Mechanics, General	5180-00-323-4692	
103	O	Tool Kit, Airframe Repairmans	5180-00-323-4876	
104	O	Tool Kit, Hydraulic Repairmans	5180-00-323-4891	
105	O	Tool Kit, Prop and Rotor Repairmans	5180-00-323-4909	
106	O	Tool Kit, Instrument Repairmans	5180-00-323-49 3	
107	O	Tool Kit, Electrical Repairmans	5180-00-323-49 5	
108	O	Tool Kit, Eng Repair	5180-00-323-4944	
109	O	Tool Kit, Power Train Repairmans	5180-00-003-5267	
110	F	Shop Set, AVIM, Electrical Instrument	4920-00-165-1453	
111	F	Shop Set, AVIM, Hydraulic	4920-00-165-1454	
112	F	Shop Set, AVIM, Machine Shop	4920-00-405-9279	
113	F	Shop Set, AVIM, Powertrain	4920-00-001-4132	
116	F	Shop Set, AVIM, Rotor Shop	4920-00-405-9270	
117	F	Shop Set, AVIM, Sheet	4920-00-166-5505	
118	F	Shop Set, AVIM, Tool Crib	4920-00-472-4183	
119	F	Shop Set, AVIM, Turbine Engine	4920-00-224-3684	
120	F	Shop Set, AVIM, Welding	4920-00-163-5093	
<b>121</b>	<b>F</b>	<b>Repair Kit, Rotor Blade</b>	<b>4920-01-035-0324</b>	<b>K747-401</b>



## SECTION IV. REMARKS

REFERENCE CODE	REMARKS
A	Limited to airframe repairman's tool kit and portable hand tools
B	Not including build up
C	Epoxy
D	Removal of nicks and scratches
E	Limited to hand stitching only
F	Refer to TM 11-1520-236-23 for removal and repair instructions
G	Refer to TM 55-2840-229-24
H	METS — Modular Engine Test System
I	Track
J	Balance
K	Seal and Coupling Replacement
L	Scratch Blending
M	Seal Replacement
N	Refer to TM 11-1520-221-20
O	Refer to TM 11-6140-203-14-2
P	Based on distribution of generator test stand
Q	Replacement of worn or elongated bushings
R	Refer to TM 9-1090-203 for Maintenance Instructions
S	Requires 2 people and excessive time
T	Restricted to AVUM units with 10 or more aircraft. Use extreme care in removal.
U	If electronic test is required, accomplish with AVIM support.
V	<b><i>Limited to Non-Divisional AVIM only</i></b>
W	<b><i>Deleted</i></b>



## APPENDIX C

### AIRCRAFT INVENTORY MASTER GUIDE

---

#### C-1. INTRODUCTION.

#### C-2. SCOPE.

Appendix C lists those items of installed or loose equipment required by and authorized for using organizations to accomplish their primary or alternate mission. This list will serve to standardize present inventory procedures, using the inventory master guide to determine the inventoriable items of installed and loose equipment. Insofar as possible, items of equipment are listed in the sequence of their physical location within the helicopter area.

#### C-3. CHANGES TO INVENTORY.

Aircraft inventory is subject to change as a result of authorized changes (MWO'S), addition or deletions of property for special missions requirements; therefore, the selection of items of inventory from the inventory master guide may or may not provide a complete inventory list. When it is known that the master guide does not provide a complete inventory list, it will be necessary to research authorized changes (MWO'S) and local command directives in order to compile an accurate and exact inventory list.

#### C-4. INVENTORY FORMS AND RECORDS.

Refer to TM 38-750 for applicable forms and records.

#### C-5. REQUIREMENTS.

#### C-6. SECURITY.

It is desired that inventory records be unclassified. Therefore, when equipment bearing a security classification or the installation of unclassified equipment is of a confidential or secret nature, accomplishment of the classification will be in accordance with security regulations.

#### C-7. INVENTORIAL ITEMS.

The selection of inventoriable items is without regard to the agency, governmental or contractual, furnishing the items.

#### a. Items to be listed:

(1) Items essential to the execution of the designated mission of the helicopter, such as electronic, photographic, armament, special mission instruments, and safety and comfort equipment.

(2) Loose equipment delivered with the helicopter and items subject to pilferage or readily converted to personal use.

(3) Modification kits which are issued or distributed to using organizations for installation and which are not immediately placed in work will be recorded on the affected aircraft's DA Form 2408-17 (Aircraft Inventory Record) and identified as loose equipment until modification is completed.

(4) Equipment required for operation in special environment.

#### b. Items to be excluded:

(1) Nonaccountable items coded as expendable in the applicable stock lists.

(2) Personal issue or furnished on unit allowance or other authority.

(3) Items or components considered as basic or integral parts of the helicopter or basic helicopter such as engines, propellers, wheels, and standard instruments.

(4) Equipment publications, check lists, and aircraft forms.

#### C-8. PERIODS OF INVENTORY.

Inventoriable items will be checked against the Aircraft Inventory Record (DA Form 2408-17) at the following periods:

a. Upon receipt of the helicopter.

b. Prior to transfer of the helicopter to another organization.

c. Upon placing helicopter in storage and upon removing from storage. Helicopter need not be inventoried while in storage.

d. Twelve months elapsed time since last inventory.

e. Loose equipment shipped under separate cover is inventoried upon transfer by the sending activity and immediately upon receipt by the receiving activity.

**C-9 INVENTORY ITEMS LISTED.**

Refer to figure C-1.

**NOTE**

**Only those items listed which are installed or assigned to a particular aircraft are to be listed on a DA Form 2408-17 (Aircraft Inventory Record) for aircraft.**

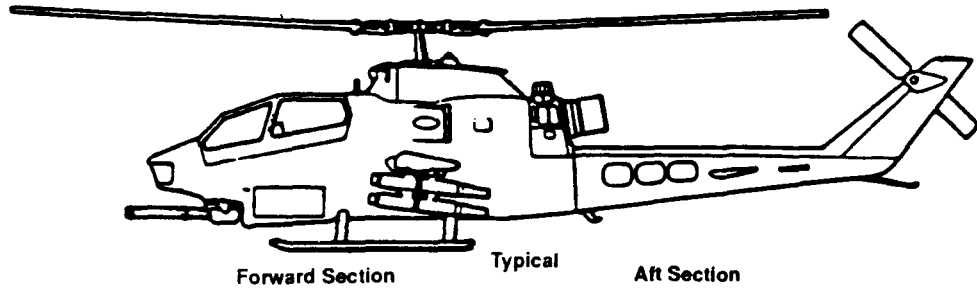

**AIRCRAFT SERIES AND NUMBER OF ITEMS NORMALLY INSTALLED**

NOMENCLATURE Forward Section (Pilot/Gunner Compartment)	AH-1P/E/F	REMARKS
Ignition Key	2	
Canopy Key	2	
Aircraft Manufacturer's Data Plate (100-030-1)	1	
Seat Belt and Shoulder Harness, Pilot	1	
Seat Belt and Shoulder Harness, Gunner	1	
Clock	1	
Compass, Magnetic, Pilot Standby	1	
First Aid Kit	1	
Fire Extinguisher Assembly	1	
Electronic Control Assembly, 7.62MM Gun <b>P</b> (11691622)	1	
Electronic Control Assembly, 20MM Gun <b>E</b> TCA (11830908)	1	
C-6533/ARC, Control, Intercommunication	2	
Audio Threshold 1021-D001	1	
Power Module E1131D	1	
Indicator, ID-2103/A Horizontal Situation (209-075-660)	1	
Indicator, ID-2104/Attitude Direction (209-075-661)	1	
Indicator, ID-2105/A Radio Magnetic Compass (212-070-180)	1	
Control C-10048/ARN-123(V)	1	
Compass C-6347/ASN Control	1	
Control C-1053/APX-100(V) <b>M</b>	1	
AN/ARC-116 or AN/ARC-164 UHF Command Communication System	1	
AN/ARC-115 Radio Set OR AN/ARC-186 Radio Set	1	
AN/ARC-114A Radio Set	1	
APN-209 RT-1115 Radar Altimeter	1	
Control HG1001 AD01 Proximity Warning	1	
Control, Navigational Select (209-077-081)	1	
Computer Display Unit, CP-1252/ASN-128 <b>M</b>	1	
Helmet, Sight System	2	
Control C-6208/APX-72 <b>P</b>	1	
Telescopic Sight Unit (M-65)	1	
Sight Hand Control (M-65)	1	
TOW Control Panel (M-65)	1	
Pilot Steering Indicator (M-65) <b>P E</b>	1	
Low G Warning System	1	
GPS Trimpack Receiver <b>M</b>	1	

Figure C-1. Inventory Item List (Sheet 1 of 2)

NOMENCLATURE	AH-1P/E/F REMARKS
Forward Section (Electronics Compartment)	
AN/ARN-89B Directional Finder (ADF)	1
CN-998/ASN.43 Gyro Directional	1
AN/ARN-89B, R-1496A Receiver	1
AN/ARN-89B, C7392A Control	1
AN/ARN-89A, AM-4859A AMplifier	1
Forward Section (General)	
Cover, Low Air Speed Sensor <b>M</b>	1
Cover, Pilot Tube	1
Cover, Canopy	1
Shield, Engine Inlet	2
Cover, Tail Pipe/IR Suppressor	1
Fitting, Jack	4
Armament Subsystem, M-197 = ~	1
Ammunition Storage Box <b>E M</b>	1
Panel, Armor	11
Armmament Subsystem, M28A1 <b>E P</b>	1
TOW Missile Launcher (M-65)	4
Computer Fire Control XM22 <b>M</b>	1
Aft Section	
Main Rotor Tie-Down (130-013-3)	1
Tail Rotor Tie-Down (204-070-450-19)	1
Mount, MT-3802/ARC	1
Mount, MT-3949A/U	1
RT-859A/APX-72 Receiver Transponder <b>P E</b>	1
Mount, MT-3809/APX-72 <b>P E</b>	1
Test Set TS-1843A/APX-72 <b>P E</b>	1
Mount, MT-3513/APX-72 <b>P E</b>	1
RT 1157/APX100(V) Receiver Transponder <b>M</b>	1
MT-4811/APX-100(V) Mount <b>M</b>	1
Transmitter, Induction Compass T-611/ASN	1
Compensator, CN-405/ASN, Magnetic Flux	1
Receiver, R-2023/ARN-123(V)	1
Mount, MT-4843/ARN-123(V)	1
Receiver/Transmitter, RT-1193( )/ASN-128 <b>M</b>	1
Signal Data Converter, CV-3338 ( )/ASN-128 <b>M</b>	1
Mount, MT-4980/ARN-123(V) <b>E</b>	1
Electronic Power Supply (M-65)	1
Missile Command Amplifier (M-65)	1
Stabilization Control Amplifier (M-65)	1

Figure C-1. Inventory Item List (Sheet 2 of 2)

C-4 Change 12

**By Order of the Secretary of the Army:**

**E. C. MEYER**  
*General, United States Army*  
*Chief of Staff*

**Official:**

**J. C. PENNINGTON**  
*Major General, United States Army*  
*The Adjutant General*

**DISTRIBUTION:**

To be distributed in accordance with DA Form 12-31, Organizational Maintenance requirements for AH-1S (PROD) aircraft.







THEN... JOT DOWN THE DOPE ABOUT IT ON THIS FORM. CAREFULLY TEAR IT OUT, FOLD IT AND DROP IT IN THE MAIL!

SOMETHING WRONG WITH THIS PUBLICATION?

FROM: (PRINT YOUR UNIT'S COMPLETE ADDRESS)

PFC JOHN DOE  
COA, 3d ENGINEER BN  
FT. LEONARDWOOD, MD 63108

DATE SENT

PUBLICATION NUMBER

TM 55-1520-236-23-2

PUBLICATION DATE

8 May 1980

PUBLICATION TITLE

ARMY MODEL AH-1P (PROD)

BE EXACT... PIN-POINT WHERE IT IS

PAGE NO.

6

PARA-GRAPH

2-1  
a

FIGURE NO.

4-3

TABLE NO.

B1

125

line 20

IN THIS SPACE TELL WHAT IS WRONG AND WHAT SHOULD BE DONE ABOUT IT:

In line 6 of paragraph 2-1a the manual states the engine has 6 cylinders. The engine on my set only has 4 cylinders. Change the manual to show 4 cylinders.

Callout 16 on figure 4-3 is pointing at a bolt. In key to figure 4-3, item 16 is called a shim - Please correct one or the other.

I ordered a gasket, item 19 on figure B-16 by NSN 2 910-00-762-3001. I got a gasket but it doesn't fit. Supply says I got what I ordered, so the NSN is wrong. Please give me a good NSN

PRINTED NAME, GRADE OR TITLE, AND TELEPHONE NUMBER

JOHN DOE, PFC (268) 317-7111

SIGN HERE:

JOHN DOE

DA FORM 2028-2  
1 JUL 79

PREVIOUS EDITIONS ARE OBSOLETE.  
DRSTS-M Overprint 1, 1 Nov 80

P.S.--IF YOUR OUTFIT WANTS TO KNOW ABOUT YOUR RECOMMENDATION MAKE A CARBON COPY OF THIS AND GIVE IT TO YOUR HEADQUARTERS.

TEAR ALONG PERFORATED LINE

1 Nov 80

FILL IN YOUR  
UNITS ADDRESS



FOLD BACK

DEPARTMENT OF THE ARMY

---

---

OFFICIAL BUSINESS

COMMANDER  
U.S. ARMY AVIATION AND TROOP COMMAND  
ATTN: AMSAT-I-MP  
4300 GOODFELLOW BOULEVARD  
ST. LOUIS, MO 63120-1798

TEAR ALONG PERFORATED LINE

RECOMMENDED CHANGES TO EQUIPMENT TECHNICAL PUBLICATIONS



THEN... JOT DOWN THE DOPE ABOUT IT ON THIS FORM. CAREFULLY TEAR IT OUT. FOLD IT AND DROP IT IN THE MAIL!

**SOMETHING WRONG WITH THIS PUBLICATION?**

FROM: (PRINT YOUR UNIT'S COMPLETE ADDRESS)

DATE SENT

PUBLICATION NUMBER

TM 55-1520-236-23-2

PUBLICATION DATE

8 May 1980

PUBLICATION TITLE

ARMY MODEL (PROD)

BE EXACT. PIN-POINT WHERE IT IS

PAGE NO	PARA-GRAPH	FIGURE NO	TABLE NO

IN THIS SPACE TELL WHAT IS WRONG AND WHAT SHOULD BE DONE ABOUT IT:

PRINTED NAME GRADE OR TITLE AND TELEPHONE NUMBER

SIGN HERE

DA FORM 2028-2  
1 JUL 79

PREVIOUS EDITIONS ARE OBSOLETE

P.S. - IF YOUR OUTFIT WANTS TO KNOW ABOUT YOUR RECOMMENDATION MAKE A CARBON COPY OF THIS AND GIVE IT TO YOUR HEADQUARTERS

1 Nov 80

FILL IN YOUR  
UNITS ADDRESS



FOLD BACK

DEPARTMENT OF THE ARMY

---

---

OFFICIAL BUSINESS

COMMANDER  
U.S. ARMY AVIATION AND TROOP COMMAND  
ATTN: AMSAT-I-MP  
4300 GOODFELLOW BOULEVARD  
ST. LOUIS, MO 63120-1798

TEAR ALONG PERFORATED LINE



FILL IN YOUR  
UNITS ADDRESS



FOLD BACK

DEPARTMENT OF THE ARMY

---

---

OFFICIAL BUSINESS

COMMANDER  
U.S. ARMY AVIATION AND TROOP COMMAND  
ATTN: AMSAT-I-MP  
4300 GOODFELLOW BOULEVARD  
ST. LOUIS, MO 63120-1798

TEAR ALONG PERFORATED LINE

RECOMMENDED CHANGES TO EQUIPMENT TECHNICAL PUBLICATIONS



THEN... JOT DOWN THE DOPE ABOUT IT ON THIS FORM. CAREFULLY TEAR IT OUT. FOLD IT AND DROP IT IN THE MAIL.

**SOMETHING WRONG WITH THIS PUBLICATION?**

FROM: (PRINT YOUR UNIT'S COMPLETE ADDRESS)

DATE SENT

PUBLICATION NUMBER

TM 55-1520-236-23-2

PUBLICATION DATE

8 May 1980

PUBLICATION TITLE

ARMY MODEL AH-1P (PROD)

BE EXACT. PIN-POINT WHERE IT IS

PAGE NO	PARA-GRAPH	FIGURE NO	TABLE NO

IN THIS SPACE TELL WHAT IS WRONG AND WHAT SHOULD BE DONE ABOUT IT:

PRINTED NAME GRADE OR TITLE AND TELEPHONE NUMBER

SIGN HERE

DA FORM 2028-2  
1 JUL 79

PREVIOUS EDITIONS ARE OBSOLETE

P.S. -IF YOUR OUTFIT WANTS TO KNOW ABOUT YOUR RECOMMENDATION MAKE A CARBON COPY OF THIS AND GIVE IT TO YOUR HEADQUARTERS

FILL IN YOUR  
UNITS ADDRESS



FOLD BACK

DEPARTMENT OF THE ARMY

---

---

OFFICIAL BUSINESS

COMMANDER  
U.S. ARMY AVIATION AND TROOP COMMAND  
ATTN: AMSAT-I-MP  
4300 GOODFELLOW BOULEVARD  
ST. LOUIS, MO 63120-1798

TEAR ALONG PERFORATED LINE



# The Metric System and Equivalents

## Linear Measure

1 centimeter = 10 millimeters = .39 inch  
 1 decimeter = 10 centimeters = 3.94 inches  
 1 meter = 10 decimeters = 39.37 inches  
 1 dekameter = 10 meters = 32.8 feet  
 1 hectometer = 10 dekameters = 328.08 feet  
 1 kilometer = 10 hectometers = 3,280.8 feet

## Weights

1 centigram = 10 milligrams = .15 grain  
 1 decigram = 10 centigrams = 1.54 grains  
 1 gram = 10 decigrams = .035 ounce  
 1 dekagram = 10 grams = .35 ounce  
 1 hectogram = 10 dekagrams = 3.52 ounces  
 1 kilogram = 10 hectograms = 2.2 pounds  
 1 quintal = 100 kilograms = 220.46 pounds  
 1 metric ton = 10 quintals = 1.1 short tons

## Liquid Measure

1 centiliter = 10 milliliters = .34 fl. ounce  
 1 deciliter = 10 centiliters = 3.38 fl. ounces  
 1 liter = 10 deciliters = 38.82 fl. ounces  
 1 dekaliter = 10 liters = 2.64 gallons  
 1 hectoliter = 10 dekaliters = 26.42 gallons  
 1 kiloliter = 10 hectoliters = 264.18 gallons

## Square Measure

1 sq. centimeter = 100 sq. millimeters = .155 sq. inch  
 1 sq. decimeter = 100 sq. centimeters = 15.5 sq. inches  
 1 sq. meter (centare) = 100 sq. decimeters = 10.76 sq. feet  
 1 sq. dekameter (are) = 100 sq. meters = 1,076.4 sq. feet  
 1 sq. hectometer (hectare) = 100 sq. dekameters = 2.47 acres  
 1 sq. kilometer = 100 sq. hectometers = .386 sq. mile

## Cubic Measure

1 cu. centimeter = 1000 cu. millimeters = .06 cu. inch  
 1 cu. decimeter = 1000 cu. centimeters = 61.02 cu. inches  
 1 cu. meter = 1000 cu. decimeters = 35.31 cu. feet

## Approximate Conversion Factors

To change	To	Multiply by	To change	To	Multiply by
inches	centimeters	2.540	ounce-inches	newton-meters	.007062
feet	meters	.305	centimeters	inches	.394
yards	meters	.914	meters	feet	3.280
miles	kilometers	1.609	meters	yards	1.094
square inches	square centimeters	6.451	kilometers	miles	.621
square feet	square meters	.093	square centimeters	square inches	.155
square yards	square meters	.836	square meters	square feet	10.764
square miles	square kilometers	2.590	square meters	square yards	1.196
acres	square hectometers	.405	square kilometers	square miles	.386
cubic feet	cubic meters	.028	square hectometers	acres	2.471
cubic yards	cubic meters	.765	cubic meters	cubic feet	35.315
fluid ounces	milliliters	29.573	cubic meters	cubic yards	1.308
pints	liters	.473	milliliters	fluid ounces	.034
quarts	liters	.946	liters	pints	2.113
gallons	liters	3.785	liters	quarts	1.057
ounces	grams	28.349	liters	gallons	.264
pounds	kilograms	.454	grams	ounces	.035
short tons	metric tons	.907	kilograms	pounds	2.205
pound-feet	newton-meters	1.365	metric tons	short tons	1.102
pound-inches	newton-meters	.11375			

## Temperature (Exact)

°F	Fahrenheit temperature	5/9 (after subtracting 32)	Celsius temperature	°C
----	------------------------	----------------------------	---------------------	----







This fine document...

Was brought to you by me:



## [Liberated Manuals -- free army and government manuals](http://www.liberatedmanuals.com)

Why do I do it? I am tired of sleazy CD-ROM sellers, who take publicly available information, slap “watermarks” and other junk on it, and sell it. Those masters of search engine manipulation make sure that their sites that sell free information, come up first in search engines. They did not create it... They did not even scan it... Why should they get your money? Why are not letting you give those free manuals to your friends?

I am setting this document FREE. This document was made by the US Government and is NOT protected by Copyright. Feel free to share, republish, sell and so on.

I am not asking you for donations, fees or handouts. If you can, please provide a link to [liberatedmanuals.com](http://www.liberatedmanuals.com), so that free manuals come up first in search engines:

<A HREF=<http://www.liberatedmanuals.com>/>Free Military and Government Manuals</A>

– Sincerely  
Igor Chudov  
<http://igor.chudov.com/>